

Version 1.1

Published November 2020

Copyright©2020 ASRock INC. All rights reserved.



Copyright Notice:

No part of this documentation may be reproduced, transcribed, transmitted, or translated in any language, in any form or by any means, except duplication of documentation by the purchaser for backup purpose, without written consent of ASRock Inc.

Products and corporate names appearing in this documentation may or may not be registered trademarks or copyrights of their respective companies, and are used only for identification or explanation and to the owners' benefit, without intent to infringe.

Disclaimer:

Specifications and information contained in this documentation are furnished for informational use only and subject to change without notice, and should not be construed as a commitment by ASRock. ASRock assumes no responsibility for any errors or omissions that may appear in this documentation.

With respect to the contents of this documentation, ASRock does not provide warranty of any kind, either expressed or implied, including but not limited to the implied warranties or conditions of merchantability or fitness for a particular purpose.

In no event shall ASRock, its directors, officers, employees, or agents be liable for any indirect, special, incidental, or consequential damages (including damages for loss of profits, loss of business, loss of data, interruption of business and the like), even if ASRock has been advised of the possibility of such damages arising from any defect or error in the documentation or product.



This device complies with Part 15 of the FCC Rules. Operation is subject to the following two conditions:

- (1) this device may not cause harmful interference, and
- (2) this device must accept any interference received, including interference that may cause undesired operation.

CALIFORNIA, USA ONLY

The Lithium battery adopted on this motherboard contains Perchlorate, a toxic substance controlled in Perchlorate Best Management Practices (BMP) regulations passed by the California Legislature. When you discard the Lithium battery in California, USA, please follow the related regulations in advance.

“Perchlorate Material-special handling may apply, see www.dtsc.ca.gov/hazardouswaste/perchlorate”

ASRock Website: <http://www.asrock.com>

AUSTRALIA ONLY

Our goods come with guarantees that cannot be excluded under the Australian Consumer Law. You are entitled to a replacement or refund for a major failure and compensation for any other reasonably foreseeable loss or damage caused by our goods. You are also entitled to have the goods repaired or replaced if the goods fail to be of acceptable quality and the failure does not amount to a major failure. If you require assistance please call ASRock Tel : +886-2-28965588 ext.123 (Standard International call charges apply)

The terms HDMI® and HDMI High-Definition Multimedia Interface, and the HDMI logo are trademarks or registered trademarks of HDMI Licensing LLC in the United States and other countries.



Motherboard Layout

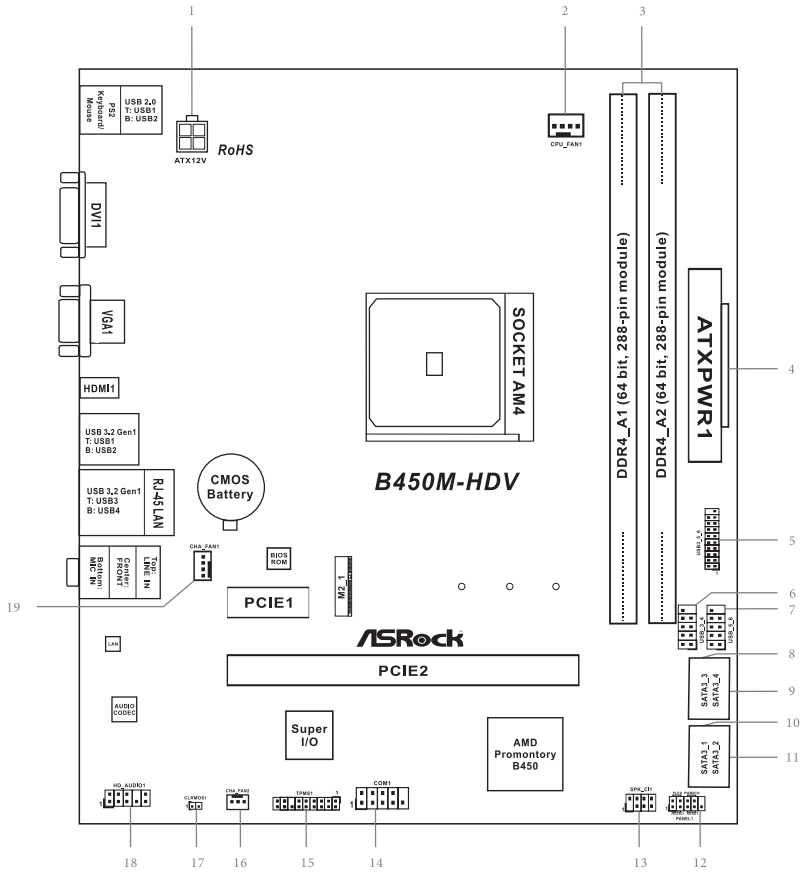

No.	Description
1	ATX 12V Power Connector (ATX12V1)
2	CPU Fan Connector (CPU_FAN1)
3	2 x 288-pin DDR4 DIMM Slots (DDR4_A1, DDR4_B1)
4	ATX Power Connector (ATXPWR1)
5	USB 3.2 Gen1 Header (USB3_5_6)
6	USB 2.0 Header (USB_3_4)
7	USB 2.0 Header (USB_5_6)
8	SATA3 Connector (SATA3_3)
9	SATA3 Connector (SATA3_4)
10	SATA3 Connector (SATA3_1)
11	SATA3 Connector (SATA3_2)
12	System Panel Header (PANEL1)
13	Chassis Intrusion and Speaker Header (SPK_CI1)
14	COM Port Header (COM1)
15	TPM Header (TPMS1)
16	Chassis Fan Connector (CHA_FAN2)
17	Clear CMOS Jumper (CLRCMOS1)
18	Front Panel Audio Header (HD_AUDIO1)
19	Chassis Fan Connector (CHA_FAN1)

I/O Panel

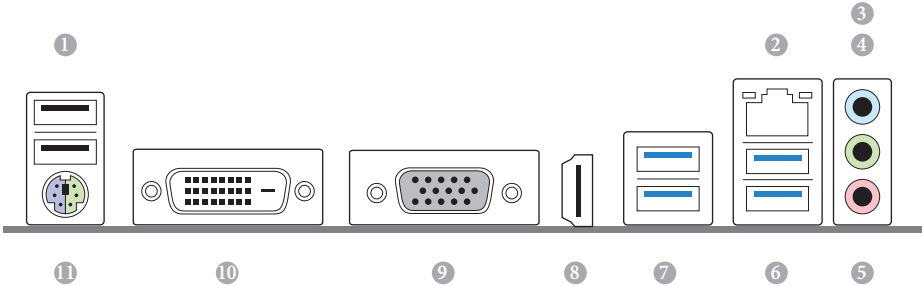

No.	Description	No.	Description
1	USB 2.0 Ports (USB12)	7	USB 3.2 Gen1 Ports (USB3_12)
2	LAN RJ-45 Port*	8	HDMI Port
3	Line In (Light Blue)**	9	D-Sub Port
4	Front Speaker (Lime)**	10	DVI-D Port
5	Microphone (Pink)**	11	PS/2 Mouse/Keyboard Port
6	USB 3.2 Gen1 Ports (USB3_34)		

*There are two LEDs on each LAN port. Please refer to the table below for the LAN port LED indications.

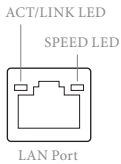

Activity / Link LED		Speed LED	
Status	Description	Status	Description
Off	No Link	Off	10Mbps connection
Blinking	Data Activity	Orange	100Mbps connection
On	Link	Green	1Gbps connection

** *Function of the Audio Ports in 7.1-channel Configuration:*

Port	Function
Light Blue (Rear panel)	Rear Speaker Out
Lime (Rear panel)	Front Speaker Out
Pink (Rear panel)	Central /Subwoofer Speaker Out
Lime (Front panel)	Side Speaker Out

Chapter 1 Introduction

Thank you for purchasing ASRock B450M-HDV R4.0 motherboard, a reliable motherboard produced under ASRock's consistently stringent quality control. It delivers excellent performance with robust design conforming to ASRock's commitment to quality and endurance.



Because the motherboard specifications and the BIOS software might be updated, the content of this manual will be subject to change without notice. In case any modifications of this manual occur, the updated version will be available on ASRock's website without further notice. If you require technical support related to this motherboard, please visit our website for specific information about the model you are using. You may find the latest VGA cards and CPU support list on ASRock's website as well. ASRock website <http://www.asrock.com>.

1.1 Package Contents

- ASRock B450M-HDV R4.0 Motherboard (Micro ATX Form Factor)
- ASRock B450M-HDV R4.0 Quick Installation Guide
- ASRock B450M-HDV R4.0 Support CD
- 2 x Serial ATA (SATA) Data Cables (Optional)
- 1 x Screw for M.2 Socket (Optional)
- 1 x I/O Panel Shield

1.2 Specifications

- Platform**
- Micro ATX Form Factor
 - Solid Capacitor design

- CPU**
- AMD AM4 Socket
 - 6 Power Phase design

- Chipset**
- AMD Promontory B450

- Memory**
- Dual Channel DDR4 Memory Technology
 - 2 x DDR4 DIMM Slots
 - AMD Ryzen series CPUs (Matisse) support DDR4 3200/2933/2667/2400/2133 ECC & non-ECC, un-buffered memory*
 - AMD Ryzen series CPUs (Pinnacle Ridge) support DDR4 3200+(OC)/2933(OC)/2667/2400/2133 ECC & non-ECC, un-buffered memory*
 - AMD Ryzen series CPUs (Picasso) support DDR4 2933/2667/2400/2133 non-ECC, un-buffered memory*
 - AMD Ryzen series CPUs (Summit Ridge) support DDR4 3200+(OC)/2933(OC)/2667/2400/2133 ECC & non-ECC, un-buffered memory*
 - AMD Ryzen series CPUs (Raven Ridge) support DDR4 3200+(OC)/2933/2667/2400/2133 non-ECC, un-buffered memory*
- * For Ryzen Series CPUs (Picasso and Raven Ridge), ECC is only supported with PRO CPUs.
- * Please refer to Memory Support List on ASRock's website for more information. (<http://www.asrock.com/>)
- * Please refer to page 10 for the table for AMD non-XMP memory frequency support. For more details, please refer to the QVL on ASRock's website.
- Max. capacity of system memory: 32GB
 - Supports Extreme Memory Profile (XMP) memory modules
 - 15 μ Gold Contact in DIMM Slots

Expansion Slot

AMD Ryzen series CPUs (Matisse, Summit Ridge and Pinnacle Ridge)

- 1 x PCI Express 3.0 x16 Slot (PCIe2: x16 mode)*

AMD Ryzen series CPUs (Picasso, Raven Ridge)

- 1 x PCI Express 3.0 x16 Slot (PCIe2: x8 mode)*

AMD Athlon series CPUs

- 1 x PCI Express 3.0 x16 Slot (PCIe2: x4 mode)*

* Supports NVMe SSD as boot disks

- 1 x PCI Express 2.0 x1 Slot

Graphics

- Integrated AMD Radeon™ Vega Series Graphics in Ryzen Series APU*

* Actual support may vary by CPU

- DirectX 12, Pixel Shader 5.0
- Shared memory default 2GB. Max Shared memory supports up to 16GB.

* The Max shared memory 16GB requires 32GB system memory installed.

- Three graphics output options: D-Sub, DVI-D and HDMI
- Supports Triple Monitor
- Supports HDMI 1.4 with max. resolution up to 4K x 2K (4096x2160) @ 24Hz / (3840x2160) @ 30Hz
- Supports DVI-D with max. resolution up to 1920x1200 @ 60Hz
- Supports D-Sub with max. resolution up to 2048x1536 @ 60Hz
- Supports Auto Lip Sync, Deep Color (12bpc), xvYCC and HBR (High Bit Rate Audio) with HDMI 1.4 Port (Compliant HDMI monitor is required)
- Supports HDCP 1.4 with DVI-D and HDMI 1.4 Ports
- Supports 4K Ultra HD (UHD) playback with HDMI 1.4 Port

Audio

- 7.1 CH HD Audio (Realtek ALC887/897 Audio Codec)
- Supports Surge Protection

LAN

- PCIE x1 Gigabit LAN 10/100/1000 Mb/s
- Realtek RTL8111H
- Supports Wake-On-LAN
- Supports Lightning/ESD Protection
- Supports Energy Efficient Ethernet 802.3az
- Supports PXE

Rear Panel I/O

- 1 x PS/2 Mouse/Keyboard Port
- 1 x D-Sub Port
- 1 x DVI-D Port
- 1 x HDMI Port
- 2 x USB 2.0 Ports (Supports ESD Protection)
- 4 x USB 3.2 Gen1 Ports (Supports ESD Protection)
- 1 x RJ-45 LAN Port with LED (ACT/LINK LED and SPEED LED)
- HD Audio Jacks: Line in / Front Speaker / Microphone

Storage

- 4 x SATA3 6.0 Gb/s Connectors, support RAID (RAID 0, RAID 1 and RAID 10), NCQ, AHCI and Hot Plug
- 1 x Ultra M.2 Socket, supports M Key type 2242/2260/2280 M.2 SATA3 6.0 Gb/s module and M.2 PCI Express module up to Gen3 x4 (32 Gb/s) (with Matisse, Picasso, Summit Ridge, Raven Ridge and Pinnacle Ridge) or Gen3 x2 (16 Gb/s) (with Athlon series APU)*
- * Supports NVMe SSD as boot disks
- * Supports ASRock U.2 Kit

Connector

- 1 x COM Port Header
- 1 x TPM Header
- 1 x Chassis Intrusion and Speaker Header
- 1 x CPU Fan Connector (4-pin)
- * The CPU Fan Connector supports the CPU fan of maximum 1A (12W) fan power.
- 2 x Chassis Fan Connectors (1 x 3-pin, 1 x 4-pin)
- * The Chassis Fan Connector supports the chassis fan of maximum 1A (12W) fan power.
- 1 x 24 pin ATX Power Connector
- 1 x 4 pin 12V Power Connector
- 1 x Front Panel Audio Connector

- 2 x USB 2.0 Headers (Support 4 USB 2.0 ports) (Supports ESD Protection)
- 1 x USB 3.2 Gen1 Header (Supports 2 USB 3.2 Gen1 ports) (Supports ESD Protection)

**BIOS
Feature**

- AMI UEFI Legal BIOS with GUI support
- Supports “Plug and Play”
- ACPI 5.1 compliance wake up events
- Supports jumperfree
- SMBIOS 2.3 support
- DRAM Voltage multi-adjustment

**Hardware
Monitor**

- CPU/Chassis temperature sensing
- CPU/Chassis Fan Tachometer
- CPU/Chassis Quiet Fan
- CPU/Chassis Fan multi-speed control
- CASE OPEN detection
- Voltage monitoring: +12V, +5V, +3.3V, Vcore

OS

- Microsoft® Windows® 10 64-bit

**Certifica-
tions**

- FCC, CE
- ErP/EuP ready (ErP/EuP ready power supply is required)

* For detailed product information, please visit our website: <http://www.asrock.com>



Please realize that there is a certain risk involved with overclocking, including adjusting the setting in the BIOS, applying Untied Overclocking Technology, or using third-party overclocking tools. Overclocking may affect your system's stability, or even cause damage to the components and devices of your system. It should be done at your own risk and expense. We are not responsible for possible damage caused by overclocking.

Chapter 2 Installation

This is a Micro ATX form factor motherboard. Before you install the motherboard, study the configuration of your chassis to ensure that the motherboard fits into it.

Pre-installation Precautions

Take note of the following precautions before you install motherboard components or change any motherboard settings.

- Make sure to unplug the power cord before installing or removing the motherboard. Failure to do so may cause physical injuries to you and damages to motherboard components.
- In order to avoid damage from static electricity to the motherboard's components, NEVER place your motherboard directly on a carpet. Also remember to use a grounded wrist strap or touch a safety grounded object before you handle the components.
- Hold components by the edges and do not touch the ICs.
- Whenever you uninstall any components, place them on a grounded anti-static pad or in the bag that comes with the components.
- When placing screws to secure the motherboard to the chassis, please do not over-tighten the screws! Doing so may damage the motherboard.

2.1 Installing the CPU

Please refer to our User Manual in the support CD for the CPU installation guide.

2.2 Installing Memory Modules (DIMM)

This motherboard provides two 288-pin DDR4 (Double Data Rate 4) DIMM slots, and supports Dual Channel Memory Technology.



1. For dual channel configuration, you always need to install identical (the same brand, speed, size and chip-type) DDR4 DIMM pairs.
2. It is unable to activate Dual Channel Memory Technology with only one memory module installed.
3. It is not allowed to install a DDR, DDR2 or DDR3 memory module into a DDR4 slot; otherwise, this motherboard and DIMM may be damaged.

AMD non-XMP Memory Frequency Support

Ryzen Series CPUs (Matisse):

UDIMM Memory Slot		Frequency
A1	B1	(Mhz)
SR	-	3200
-	SR	3200
DR	-	3200
-	DR	3200
SR	SR	3200
DR	DR	3200

Ryzen Series CPUs (Pinnacle Ridge):

UDIMM Memory Slot		Frequency (Mhz)
A1	B1	
SR	-	2933
-	SR	2933
DR	-	2933
-	DR	2933
SR	SR	2933
DR	DR	2933

Ryzen Series CPUs (Picasso):

UDIMM Memory Slot		Frequency (Mhz)
A1	B1	
SR	-	2933
-	SR	2933
DR	-	2667
-	DR	2667
SR	SR	2933
DR	DR	2667

Ryzen Series CPUs (Summit Ridge):

UDIMM Memory Slot		Frequency
A1	B1	(Mhz)
SR	-	2667
-	SR	2667
DR	-	2667
-	DR	2667
SR	SR	2667
DR	DR	2667

Ryzen Series CPUs (Raven Ridge):

UDIMM Memory Slot		Frequency
A1	B1	(Mhz)
SR	-	2933
-	SR	2933
DR	-	2667
-	DR	2667
SR	SR	2933
DR	DR	2667

SR: Single rank DIMM, 1Rx4 or 1Rx8 on DIMM module label

DR: Dual rank DIMM, 2Rx4 or 2Rx8 on DIMM module label



The DIMM only fits in one correct orientation. It will cause permanent damage to the motherboard and the DIMM if you force the DIMM into the slot at incorrect orientation.

1

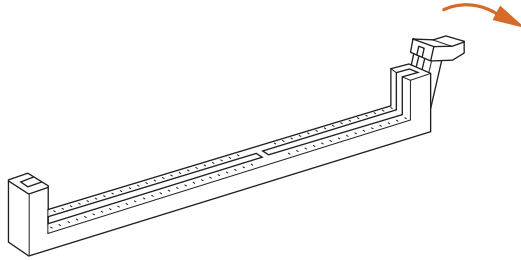

2

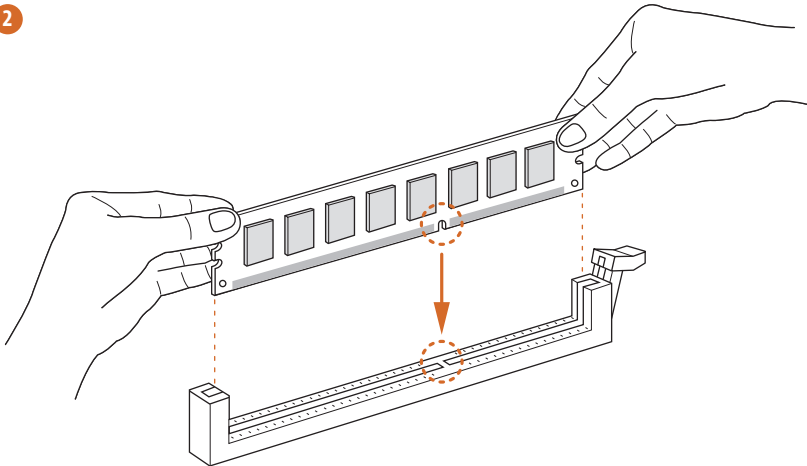

3

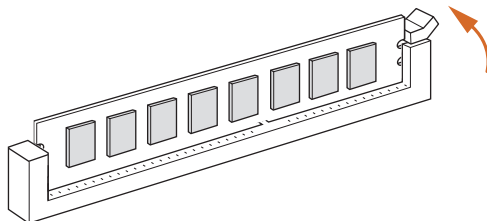

2.3 Expansion Slots (PCI Express Slots)

There are 2 PCI Express slots on the motherboard.



Before installing an expansion card, please make sure that the power supply is switched off or the power cord is unplugged. Please read the documentation of the expansion card and make necessary hardware settings for the card before you start the installation.

PCIe slots:

PCIe1 (PCIe 2.0 x1 slot) is used for PCI Express x1 lane width cards.

PCIe2 (PCIe 3.0 x16 slot) is used for PCI Express x16 lane width graphics cards.

PCIe Slot Configurations

	PCIe1	PCIe2
Ryzen Series CPUs (Matisse)	x1	x16
Ryzen Series CPUs (Summit Ridge)	x1	x16
Ryzen Series CPUs (Pinnacle Ridge)	x1	x16
Ryzen Series CPUs (Picasso)	x1	x8
Ryzen Series CPUs (Raven Ridge)	x1	x8
Athlon Series CPUs	x1	x4

2.4 Jumpers Setup

The illustration shows how jumpers are setup. When the jumper cap is placed on the pins, the jumper is “Short”. If no jumper cap is placed on the pins, the jumper is “Open”.

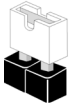

Short



Open

Clear CMOS Jumper
(CLRMOSE1)
(see p.1, No. 17)



2-pin Jumper

Short: Clear CMOS

Open: Default

CLRMOSE1 allows you to clear the data in CMOS. To clear and reset the system parameters to default setup, please turn off the computer and unplug the power cord from the power supply. After waiting for 15 seconds, use a jumper cap to short the pins on CLRMOSE1 for 5 seconds. However, please do not clear the CMOS right after you update the BIOS. If you need to clear the CMOS when you just finish updating the BIOS, you must boot up the system first, and then shut it down before you do the clear-CMOS action. Please be noted that the password, date, time, and user default profile will be cleared only if the CMOS battery is removed. Please remember to remove the jumper cap after clearing the CMOS.



If you clear the CMOS, the case open may be detected. Please adjust the BIOS option “Clear Status” to clear the record of previous chassis intrusion status.

2.5 Onboard Headers and Connectors



Onboard headers and connectors are NOT jumpers. Do NOT place jumper caps over these headers and connectors. Placing jumper caps over the headers and connectors will cause permanent damage to the motherboard.

System Panel Header
(9-pin PANEL1)
(see p.1, No. 12)

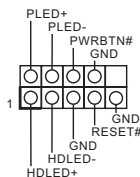

Connect the power switch, reset switch and system status indicator on the chassis to this header according to the pin assignments below. Note the positive and negative pins before connecting the cables.



PWRBTN (Power Switch):

Connect to the power switch on the chassis front panel. You may configure the way to turn off your system using the power switch.

RESET (Reset Switch):

Connect to the reset switch on the chassis front panel. Press the reset switch to restart the computer if the computer freezes and fails to perform a normal restart.

PLED (System Power LED):

Connect to the power status indicator on the chassis front panel. The LED is on when the system is operating. The LED keeps blinking when the system is in S3 sleep state. The LED is off when the system is in S4 sleep state or powered off (S5).

HDLED (Hard Drive Activity LED):

Connect to the hard drive activity LED on the chassis front panel. The LED is on when the hard drive is reading or writing data.

The front panel design may differ by chassis. A front panel module mainly consists of power switch, reset switch, power LED, hard drive activity LED, speaker and etc. When connecting your chassis front panel module to this header, make sure the wire assignments and the pin assignments are matched correctly.

Chassis Intrusion and Speaker Header
(7-pin SPK_CI1)
(see p.1, No. 13)

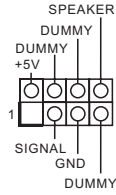

Please connect the chassis intrusion and the chassis speaker to this header.

Serial ATA3 Connectors

Right Angle:

(SATA3_1:
see p.1, No. 10)
(SATA3_2:
see p.1, No. 11)
(SATA3_3:
see p.1, No. 8)
(SATA3_4:
see p.1, No. 9)

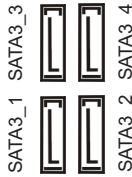

These four SATA3 connectors support SATA data cables for internal storage devices with up to 6.0 Gb/s data transfer rate.

USB 2.0 Headers
(9-pin USB_3_4)
(see p.1, No. 6)
(9-pin USB_5_6)
(see p.1, No. 7)

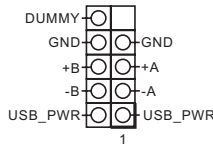

There are two headers on this motherboard. Each USB 2.0 header can support two ports.

USB 3.2 Gen1 Header
(19-pin USB3_5_6)
(see p.1, No. 5)

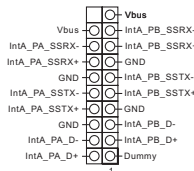

There is one header on this motherboard. This USB 3.2 Gen1 header can support two ports.

Front Panel Audio Header
(9-pin HD_AUDIO1)
(see p.1, No. 18)

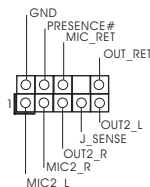

This header is for connecting audio devices to the front audio panel.



- High Definition Audio supports Jack Sensing, but the panel wire on the chassis must support HDA to function correctly. Please follow the instructions in our manual and chassis manual to install your system.
- If you use an AC'97 audio panel, please install it to the front panel audio header by the steps below:
 - Connect Mic_IN (MIC) to MIC2_L.
 - Connect Audio_R (RIN) to OUT2_R and Audio_L (LIN) to OUT2_L.
 - Connect Ground (GND) to Ground (GND).
 - MIC_RET and OUT_RET are for the HD audio panel only. You don't need to connect them for the AC'97 audio panel.
 - To activate the front mic, go to the "FrontMic" Tab in the Realtek Control panel and adjust "Recording Volume".

Chassis Fan Connectors
 (4-pin CHA_FAN1)
 (see p.1, No. 19)

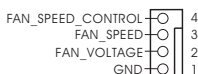

Please connect fan cables to the fan connectors and match the black wire to the ground pin.

(3-pin CHA_FAN2)
 (see p.1, No. 16)

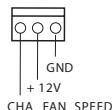

CPU Fan Connector
 (4-pin CPU_FAN1)
 (see p.1, No. 2)

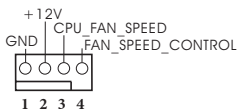

This motherboard provides a 4-Pin CPU fan (Quiet Fan) connector. If you plan to connect a 3-Pin CPU fan, please connect it to Pin 1-3.

ATX Power Connector
 (24-pin ATXPWR1)
 (see p.1, No. 4)

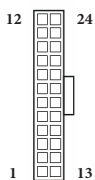

This motherboard provides a 24-pin ATX power connector. To use a 20-pin ATX power supply, please plug it along Pin 1 and Pin 13.

ATX 12V Power
Connector
(4-pin ATX12V1)
(see p.1, No. 1)



This motherboard
provides a 4-pin ATX 12V
power connector.

Serial Port Header
(9-pin COM1)
(see p.1, No. 14)

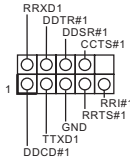

This COM1 header
supports a serial port
module.

TPM Header
(17-pin TPMS1)
(see p.1, No. 15)

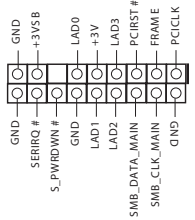

This connector supports
Trusted Platform Module
(TPM) system, which can
securely store keys, digital
certificates, passwords,
and data. A TPM system
also helps enhance
network security, protects
digital identities, and
ensures platform integrity.

2.6 M.2_SSD (NGFF) Module Installation Guide

The M.2, also known as the Next Generation Form Factor (NGFF), is a small size and versatile card edge connector that aims to replace mPCIe and mSATA. The Ultra M.2 Socket supports SATA3 6.0 Gb/s module and M.2 PCI Express module up to Gen3 x4 (32 Gb/s) (with Matisse, Picasso, Summit Ridge, Raven Ridge and Pinnacle Ridge) or Gen3 x2 (16 Gb/s) (with Athlon series APU).

Installing the M.2_SSD (NGFF) Module

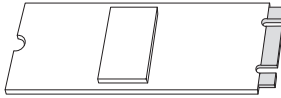

Step 1

Prepare a M.2_SSD (NGFF) module and the screw.

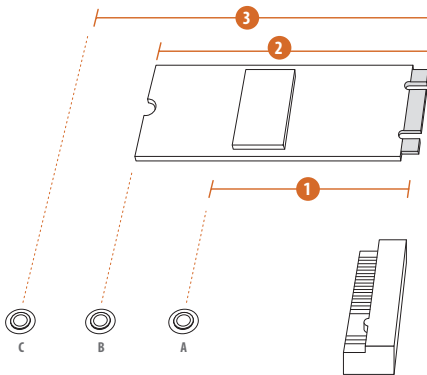

Step 2

Depending on the PCB type and length of your M.2_SSD (NGFF) module, find the corresponding nut location to be used.

No.	1	2	3
Nut Location	A	B	C
PCB Length	4.2cm	6cm	8cm
Module Type	Type 2242	Type2260	Type 2280

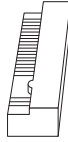
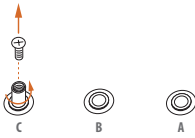
**Step 3**

Move the standoff based on the module type and length. The standoff is placed at the nut location C by default. Skip Step 3 and 4 and go straight to Step 5 if you are going to use the default nut. Otherwise, release the standoff by hand.

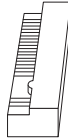
**Step 4**

Peel off the yellow protective film on the nut to be used. Hand tighten the standoff into the desired nut location on the motherboard.

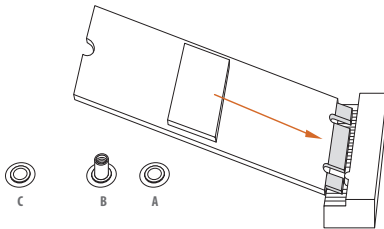
**Step 5**

Gently insert the M.2 (NGFF) SSD module into the M.2 slot. Please be aware that the M.2 (NGFF) SSD module only fits in one orientation.

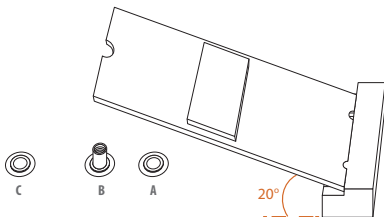

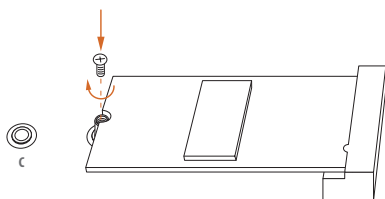

Step 6

Tighten the screw with a screwdriver to secure the module into place. Please do not overtighten the screw as this might damage the module.

M.2_SSD (NGFF) Module Support List

Vendor	Interface	P/N
SanDisk	PCIe	SanDisk-SD6PP4M-128G(Gen2 x2)
Intel	PCIe	INTEL 6000P-SSDPEKKF256G7 (nvme)
Intel	PCIe	INTEL 6000P-SSDPEKKF512G7 (nvme)
Kingston	PCIe	Kingston SHPM2280P2 / 240G (Gen2 x4)
Samsung	PCIe	Samsung XP941-MZHPU512HCGL(Gen2x4)
ADATA	SATA	ADATA - AXNS381E-128GM-B
Crucial	SATA	Crucial-CT240M500SSD4-240GB
ezlink	SATA	ezlink P51B-80-120GB
Intel	SATA	INTEL 540S-SSDSCKKW240H6-240GB
Kingston	SATA	Kingston SM2280S3G2/120G - Win8.1
Kingston	SATA	Kingston-RBU-SNS8400S3 / 180GD
LITEON	SATA	LITEON LJH-256V2G-256GB (2260)
PLEXTOR	SATA	PLEXTOR PX-128M6G-2260-128GB
PLEXTOR	SATA	PLEXTOR PX-128M7VG-128GB
SanDisk	SATA	SanDisk X400-SD8SN8U-128G
SanDisk	SATA	Sandisk Z400s-SD8SNAT-128G-1122
SanDisk	SATA	SanDisk-SD6SNIM-128G
Transcend	SATA	Transcend TS256GMTS800-256GB
V-Color	SATA	V-Color 120G
V-Color	SATA	V-Color 240G
WD	SATA	WD GREEN WDS240G1G0B-00RC30

For the latest updates of M.2_SSD (NFGG) module support list, please visit our website for details: <http://www.asrock.com>

Technische Daten

- Plattform**
- Micro-ATX-Formfaktor
 - Feststoffkondensator-Design

- Prozessor**
- AMD-AM4-Sockel
 - 6-Leistungsphasendesign

- Chipsatz**
- AMD Promontory B450

- Speicher**
- Dualkanal-DDR4-Speichertechnologie
 - 2 x DDR4-DIMM-Steckplätze
 - Prozessoren der AMD-Ryzen-Serie (Matisse) unterstützen DDR4 3200/2933/2667/2400/2133 ECC und non-ECC, ungepufferter Speicher*
 - Prozessoren der AMD-Ryzen-Serie (Pinnacle Ridge) unterstützen DDR4 3200+(OC)/2933(OC)/2667/2400/2133 ECC und non-ECC, ungepufferter Speicher*
 - Prozessoren der AMD-Ryzen-Serie (Picasso) unterstützen DDR4 2933/2667/2400/2133 ECC und non-ECC, ungepufferter Speicher*
 - Prozessoren der AMD-Ryzen-Serie (Summit Ridge) unterstützen DDR4 3200+(OC)/2933(OC)/2667/2400/2133 ECC und non-ECC, ungepufferter Speicher*
 - Prozessoren der AMD-Ryzen-Serie (Raven Ridge) unterstützen DDR4 3200+(OC)/2933/2667/2400/2133 non-ECC, ungepufferter Speicher*
- * Für Prozessoren der Ryzen-Serie (Picasso- und Raven Ridge), ECC wird nur mit PRO-Prozessoren unterstützt.
- * Weitere Informationen finden Sie in der Speicherkompatibilitätsliste auf der ASRock-Webseite. (<http://www.asrock.com/>)
- * Die Tabelle für AMDs Non-XMP-Speicherfrequenzen finden Sie auf Seite 10. Weitere Einzelheiten finden Sie in der QVL auf ASRocks Webseite.
- Systemspeicher, max. Kapazität: 32GB
 - Unterstützt Extreme-Memory-Profile- (XMP) Speichermodule
 - 15-µ-Goldkontakt in DIMM-Steckplätze

- Erweiterungssteckplatz**
- CPUs der AMD-Ryzen-Serie (Matisse, Summit Ridge und Pinnacle Ridge)**
- 1 x PCI-Express 3.0-x16-Steckplatz (PCI-E2:x16-Modus)*
- CPUs der AMD-Ryzen-Serie (Picasso, Raven Ridge)**
- 1 x PCI-Express 3.0-x16-Steckplatz (PCI-E2:x8-Modus)*
- CPUs der AMD-Athlon-Serie**
- 1 x PCI-Express 3.0-x16-Steckplatz (PCI-E2:x4-Modus)*

- * Unterstützt NVMe-SSD als Bootplatte
- 1 x PCI-Express 2.0-x1-Steckplatz

Grafikkarte

- Integrierte Grafikkarte der AMD-Radeon™-Vega-Serie in APU der Ryzen-Serie*

* Tatsächliche Unterstützung kann je nach Prozessor variieren

- DirectX 12, Pixel Shader 5.0
- Freigabespeicher von standardmäßig 2 GB, max. Freigabespeicher unterstützt bis zu 16 GB.

* Der max. Freigabespeicher von 16 GB erfordert die Installation von 32 GB Systemspeicher.

- Drei Grafikkarten-Ausgangsoptionen: D-Sub, DVI-D und HDMI
- Unterstützt drei Monitore
- Unterstützt HDMI 1.4 mit maximaler Auflösung von 4K x 2K (4096 x 2160) bei 24 Hz / (3840 x 2160) bei 30 Hz
- Unterstützt DVI-D mit maximaler Auflösung von 1920 x 1200 bei 60 Hz
- Unterstützt D-Sub mit maximaler Auflösung von 2048 x 1536 bei 60 Hz
- Unterstützt Auto-Lippensynchronizität, hohe Farbtiefe (12 bpc), xvYCC und HBR (Audio mit hoher Bitrate) mit HDMI 1.4-Port (konformer HDMI-Monitor erforderlich)
- Unterstützt HDCP 1.4 mit DVI-D- und HDMI 1.4-Ports
- Unterstützt 4K-Ultra-HD- (UHD) Wiedergabe mit HDMI 1.4-Port

Audio

- 7.1-Kanal-HD-Audio (Realtek ALC887/897-Audiocodex)
- Unterstützt Überspannungsschutz

LAN

- PCIE-x1-Gigabit-LAN 10/100/1000 Mb/s
- Realtek RTL8111H
- Unterstützt Wake-On-LAN
- Unterstützt Schutz gegen Blitzschlag/elektrostatische Entladung
- Unterstützt energieeffizientes Ethernet 802.3az
- Unterstützt PXE

Rückblende, E/A

- 1 x PS/2-Maus-/Tastaturanschluss
- 1 x D-Sub-Port
- 1 x DVI-D-Port
- 1 x HDMI-Port
- 2 x USB-2.0-Ports (unterstützt Schutz gegen elektrostatische Entladung)
- 4 x USB-3.2-Gen1-Ports (unterstützt Schutz gegen elektrostatische Entladung)
- 1 x RJ-45-LAN-Port mit LED (Aktivität/Verbindung-LED und Geschwindigkeit-LED)
- HD-Audioanschlüsse: Line-in / Vorderer Lautsprecher / Mikrofon

Speicher

- 4 x SATA-III-6,0-Gb/s-Anschlüsse, unterstützt RAID (RAID 0, RAID 1 und RAID 10), NCQ, AHCI und Hot-Plugging
- 1 x Ultra-M.2-Sockel, unterstützt M-Key-Typ-2242/2260/2280-M.2-SATA-III-6,0-Gb/s-Modul und M.2-PCI-Express-Modul bis Gen3 x 4 (32 Gb/s) (mit Matisse, Picasso, Summit Ridge, Raven Ridge und Pinnacle Ridge) oder Gen3 x 2 (16 Gb/s) (mit Athlon Serie-APU)*

* Unterstützt NVMe-SSD als Bootplatte

* Unterstützt ASRock U.2-Kit

Anschluss

- 1 x COM-Anschluss-Stiftleiste
- 1 x TPM-Stiftleiste
- 1 x Gehäuseeingriff- und Lautsprecher-Stiftleiste
- 1 x CPU-Lüfteranschluss (4-polig)

* Der CPU-Lüfteranschluss unterstützt einen CPU-Lüfter mit einer maximalen Lüfterleistung von 1 A (12 W).

- 2 x Gehäuselüfteranschlüsse (1 x 4-polig, 1 x 3-polig)

* Der CPU-Lüfteranschluss unterstützt einen CPU-Lüfter mit einer maximalen Lüfterleistung von 1 A (12 W).

- 1 x 24-poliger ATX-Netzanschluss
- 1 x 4-poliger 12-V-Netzanschluss
- 1 x Audioanschluss an Frontblende
- 2 x USB 2.0-Stiftleisten (unterstützt 4 USB 2.0-Ports)
(unterstützt Schutz gegen elektrostatische Entladung)
- 1 x USB 3.2 Gen1-Stiftleiste (unterstützt zwei USB 3.2 Gen1-Ports)
(unterstützt Schutz gegen elektrostatische Entladung)

Betriebssystem

- Microsoft® Windows® 10, 64 Bit

Spécifications

- Plateforme**
- Facteur de forme Micro ATX
 - Conception à condensateurs solides

- Processeur**
- AM4 à socket AMD
 - Alimentation à 6 phases

- Chipset**
- AMD Promontory B450

- Mémoire**
- Technologie mémoire double canal DDR4
 - 2 x fentes DIMM DDR4
 - Les processeurs AMD série Ryzen (Matisse) prennent en charge les mémoires sans tampon ECC et non ECC DDR4 3200/2933/2667/2400/2133*
 - Les processeurs AMD série Ryzen (Pinnacle Ridge) prennent en charge les mémoires sans tampon* ECC et non ECC DDR4 3200+(OC)/2933(OC)/2667/2400/2133
 - Les processeurs AMD série Ryzen (Picasso) prennent en charge les mémoires sans tampon ECC et non ECC DDR4 2933/2667/2400/2133*
 - Les processeurs AMD série Ryzen (Summit Ridge) prennent en charge les mémoires sans tampon* ECC et non ECC DDR4 3200+(OC)/2933(OC)/2667/2400/2133
 - Les processeurs AMD série Ryzen (Raven Ridge) prennent en charge les mémoires sans tampon* non ECC DDR4 3200+(OC)/2933/2667/2400/2133
- * Sur les processeurs série Ryzen (Picasso et Raven Ridge), ECC est pris en charge uniquement avec les processeurs PRO.
- * Veuillez consulter la liste de prise en charge des mémoires sur le site Web d'ASRock pour de plus amples informations. (<http://www.asrock.com/>)
- * Veuillez consulter la page 10 pour la table de prise en charge de la fréquence de la mémoire AMD non XMP. Pour plus de détails, veuillez consulter le QVL sur le site Web d'ASRock.
- Capacité max. de la mémoire système : 32GB
 - Prend en charge les modules mémoire Extreme Memory Profile (XMP)
 - Contacts dorés 15µ sur fentes DIMM

Fente d'expansion

Processeurs AMD série Ryzen (Matisse, Summit Ridge et Pinnacle Ridge)

- 1 x fente PCI Express 3.0 x 16 (PCIE2: mode x16)*

Processeurs AMD série Ryzen (Picasso, Raven Ridge)

- 1 x fente PCI Express 3.0 x 16 (PCIE2: mode x8)*

Processeurs AMD série Athlon

- 1 x fente PCI Express 3.0 x16 (PCIE2: mode x4)*

* Prend en charge les SSD NVMe comme disques de démarrage

- 1 x fente PCI Express 2.0 x1

Graphiques

- Carte graphique AMD Radeon™ série Vega intégrée dans APU série Ryzen*

* La prise en charge réelle peut varier selon le processeur

- DirectX 12, Pixel Shader 5.0
- Mémoire partagée par défaut 2 Go, Mémoire partagée maximum prise en charge 16 Go.

* La mémoire partagée maximum de 16 Go nécessite 32 Go de mémoire système installée.

- Trois options de sortie graphique : D-Sub, DVI-D et HDMI
- Prend en charge la configuration à triple moniteurs
- Prend en charge la technologie HDMI 1.4 avec résolution maximale de 4K × 2K (4096x2160) @ 24Hz / (3840x2160) @ 30Hz
- Prend en charge le mode DVI-D avec une résolution maximale de 1920x1200 @ 60Hz
- Prend en charge le mode D-Sub avec une résolution maximale de 2048x1536 @ 60 Hz
- Prend en charge les technologies Auto Lip Sync, Deep Color (12bpc), xvYCC et HBR (High Bit Rate Audio) avec port HDMI 1.4 (un écran compatible HDMI est requis)
- Prend en charge HDCP 1.4 via ports DVI-D et HDMI 1.4
- Prend en charge la lecture 4K Ultra HD (UHD) avec le port HDMI 1.4

Audio

- Audio 7.1 CH HD (Codec audio Realtek ALC887/897)
- Prend en charge la protection contre les surtensions

Réseau

- PCIE x1 Gigabit LAN 10/100/1000 Mo/s
- Realtek RTL8111H
- Prend en charge la fonction Wake-On-LAN
- Prend en charge la protection contre la foudre/les décharges électrostatiques
- Prend en charge la fonction d'économie d'énergie Ethernet 802.3az
- Prend en charge PXE

Connectique du panneau arrière

- 1 x port souris/clavier PS/2
- 1 x port D-Sub
- 1 x port DVI-D
- 1 x port HDMI
- 2 x ports USB 2.0 (Protection contre les décharges électrostatiques)
- 4 x ports USB 3.2 Gen1 (Protection contre les décharges électrostatiques)

- 1 x port RJ-45 LAN avec LED (LED ACT/LIEN et LED VITESSE)
- Connecteurs jack audio HD : Entrée ligne / haut-parleur avant / microphone

Stockage

- 4 x connecteurs SATA3 6,0 Gbit/s, prise en charge de RAID (RAID 0, RAID 1 et RAID 10), NCQ, AHCI et branchement à chaud
- 1 x socket Ultra M.2, prend en charge les modules M.2 SATA3 6,0 Go/s type 2242/2260/2280 touche M et M.2 PCI Express jusqu'à Gen3 x4 (32 Go/s) (avec Matisse, Picasso, Summit Ridge, Raven Ridge et Pinnacle Ridge) ou Gen3 x2 (16 Go/s) (avec APU Athlon série)*

- * Prend en charge les SSD NVMe comme disques de démarrage
- * Prend en charge le kit ASRock U.2

Connecteur

- 1 x embase pour port COM
- 1 x embase TPM
- 1 x prise DEL d'alimentation et emplacement sur châssis
- 1 x connecteur pour ventilateur de CPU (4 broches)
- * Le connecteur pour ventilateur de CPU prend en charge un ventilateur de CPU d'une puissance maximale de 1 A (12 W).
 - 2 x connecteurs pour ventilateur de châssis (1 x 4 broches, 1 x 3 broches)
- * Le connecteur pour ventilateur de CPU prend en charge un ventilateur de CPU d'une puissance maximale de 1 A (12 W).
 - 1 x connecteur d'alimentation ATX 24 broches
 - 1 x connecteur d'alimentation 12 V 4 broches
 - 1 x connecteur audio panneau frontal
 - 2 x embases USB 2.0 (4 ports USB 2.0 pris en charge) (Protection contre les décharges électrostatiques)
 - 1 x embase USB 3.2 Gen1 (2 ports USB 3.2 Gen1 pris en charge) (Protection contre les décharges électrostatiques)

Système d'exploitation

- Microsoft® Windows® 10 64 bits

Specifiche

- Piattaforma**
- Fattore di forma Micro ATX
 - Design condensatore solido

- CPU**
- AMD AM4 Socket
 - Potenza a 6 fasi

- Chipset**
- AMD Promontory B450

- Memoria**
- Tecnologia memoria DDR4 Dual Channel
 - 2 x alloggi DIMM DDR4
 - Le CPU serie AMD Ryzen (Matisse) supportano DDR4 3200/2933/2667/2400/2133 ECC e non ECC, senza buffer*
 - Le CPU serie AMD Ryzen (Pinnacle Ridge) supportano DDR4 3200+(OC)/2933(OC)/2667/2400/2133 non ECC, senza buffer*
 - Le CPU serie AMD Ryzen (Picasso) supportano DDR4 2933/2667/2400/2133 ECC e non ECC, senza buffer*
 - Le CPU serie AMD Ryzen (Summit Ridge) supportano DDR4 3200+(OC)/2933(OC)/2667/2400/2133 non ECC, senza buffer*
 - Le CPU serie AMD Ryzen (Raven Ridge) supportano DDR4 3200+(OC)/2933/2667/2400/2133 non ECC, senza buffer*
- * Per le CPU serie Ryzen (Picasso e Raven Ridge), è supportata solo la memoria ECC senza CPU PRO.
- * Per maggiori informazioni fare riferimento all'elenco dei supporti di memoria sul sito di ASRock. (<http://www.asrock.com/>)
- * Fare riferimento a pagina 10 per la tabella delle frequenze di memoria AMD non-XMP supportate. Per altri dettagli, fare riferimento a QVL sul sito ASRock.
- Capacità max. della memoria di sistema: 32GB
 - Supporta moduli di memoria Extreme Memory Profile (XMP)
 - Contatti d'oro 15µ negli alloggi DIMM

- Alloggio d'espansione**
- CPU serie AMD Ryzen (Matisse, Summit Ridge e Pinnacle Ridge)**

- 1 x Alloggio PCI Express 3.0 x16 (PCIe2:modalità x16)*

- CPU serie AMD Ryzen (Picasso, Raven Ridge)**

- 1 x Alloggio PCI Express 3.0 x16 (PCIe2:modalità x8)*

- CPU serie AMD Athlon**

- 1 x Alloggio PCI Express 3.0 x16 (PCIe2:modalità x4)*

- * Supporto di SSD NVMe come disco d'avvio

- 1 x Alloggio PCI Express 2.0 x1

Grafica

- Grafica AMD Radeon™ serie Vega integrata nelle APU serie Ryzen*

* Il supporto effettivo può variare in base alla CPU

- DirectX 12, Pixel Shader 5.0
- Memoria condivisa predefinita 2GB, la memoria condivisa massima supporta fino a 16GB.

* La memoria condivisa massima di 16 GB richiede che sia installata una memoria di sistema da 32 GB.

- Tre opzioni di output grafico: D-Sub, DVI-D e HDMI
- Supporto di tre monitor
- Supporta HDMI 1.4 con risoluzione massima fino a 4K x 2K (4096x2160) a 24Hz / (3840x2160) a 30Hz
- Supporta DVI-D con una risoluzione max. fino a 1920 x 1200 a 60 Hz
- Supporta D-Sub con una risoluzione max. fino a 2048x1536 a 60 Hz
- Supporto delle funzioni Auto Lip Sync, Deep Color (12bpc), xvYCC e HBR (High Bit Rate Audio) con porta HDMI 1.4 (è necessario un monitor compatibile HDMI)
- Supporto di HDCP 1.4 con le porte DVI-D e HDMI 1.4
- Supporto riproduzione 4K Ultra HD (UHD) sulla porta HDMI 1.4

Audio

- Audio HD 7.1 CH (codec audio Realtek ALC887/897)
- Supporta protezione da sovratensione

LAN

- 1 x PCIE LAN Gigabit 10/100/1000 Mb/s
- Realtek RTL8111H
- Supporto WOL (Wake-On-LAN)
- Supporta protezione da fulmini/scariche elettrostatiche
- Supporto Energy Efficient Ethernet 802.3az
- Supporto PXE

I/O pannello posteriore

- 1 x porta mouse/tastiera PS/2
- 1 x porta D-Sub
- 1 x porta DVI-D
- 1 x porta HDMI
- 2 x porte USB 2.0 (supporto protezione da scariche elettrostatiche)
- 4 x porte USB 3.2 Gen1 (supporto protezione da scariche elettrostatiche)

- 1 x porta LAN RJ-45 con LED (ACT/LINK LED e SPEED LED)
- Connettori audio HD: Ingresso linea / altoparlante frontale / microfono

Archiviazione

- 4 x connettori SATA3 6,0 Gb/s, supporto RAID (RAID 0, RAID 1, e RAID 10), NCQ, AHCI e Hot Plug
- 1 x socket Ultra M.2, supporta il modulo M.2 SATA3 6,0 Gb/s di tipo M Key 2242/2260/2280 ed il modulo M.2 PCI Express fino a Gen3 x4 (32 Gb/s) (con Matisse, Picasso, Summit Ridge, Raven Ridge e Pinnacle Ridge) o Gen3 x2 (16 Gb/s) (con APU Anthlon serie)*

* Supporto di SSD NVMe come disco d'avvio

* Supporta kit ASRock U.2

Connettore

- 1 x connettore porta COM
- 1 x connettore TPM
- 1 x collegamento altoparlante e intrusione telaio
- 1 x connettore ventola CPU (4-pin)

* Il connettore ventola CPU supporta ventole CPU con potenza massima di 1 A (12 W).

- 2 x connettori ventola telaio (1 x 4 pin, 1 x 3 pin)

* Il connettore ventola CPU supporta ventole CPU con potenza massima di 1 A (12 W).

- 1 x connettore alimentazione ATX 24 pin
- 1 x connettore alimentazione 12 V 4-pin
- 1 x connettore audio pannello frontale
- 2 x connettori USB 2.0 (supporto di 4 porte USB 2.0) (supporta protezione da scariche elettrostatiche)
- 1 x connettore USB 3.2 Gen1 (supporto di 2 porte USB 3.2 Gen1) (supporto protezione da scariche elettrostatiche)

SO

- Microsoft® Windows® 10 64 bit

Especificaciones

Plataforma

- Factor de forma Micro ATX
- Diseño de condensador sólido

CPU

- AM4 con zócalo AMD
- Diseño de 6 fases de alimentación

Conjunto de chips

- AMD Promontory B450

Memoria

- Tecnología de memoria DDR4 de doble canal
- 2 x ranuras DIMM DDR4
- Las CPU de la serie AMD (Matisse) admiten memoria sin búfer DDR4 3200/2933/2667/2400/2133 ECC y no ECC*
- Las CPU de la serie AMD (Pinnacle Ridge) admiten memoria sin búfer DDR4 3200+(OC)/2933(OC)/2667/2400/2133 ECC y no ECC*
- Las CPU de la serie AMD (Picasso) admiten memoria sin búfer DDR4 2933/2667/2400/2133 ECC y no ECC*
- Las CPU de la serie AMD (Summit Ridge) admiten memoria sin búfer DDR4 3200+(OC)/2933(OC)/2667/2400/2133 ECC y no ECC*
- Las CPU de la serie AMD (Raven Ridge) admiten memoria sin búfer no ECC DDR4 3200+(OC)/2933/2667/2400/2133*

* Para CPU de la serie Ryzen (Picasso y Raven Ridge), ECC solamente se admite con CPU PRO.

* Para obtener más información, consulte la lista de memorias compatibles en el sitio web de ASRock. (<http://www.asrock.com/>)

* Consulte la página 10 para acceder a la tabla de compatibilidad de frecuencias de memoria no XMP de AMD. Para obtener más información, consulte la QVL en el sitio web de ASRock.

- Capacidad máxima de memoria del sistema: 32GB
- Admite módulos de memoria Extreme Memory Profile (XMP)
- Contacto 15µ Gold en ranuras DIMM

Ranura de expansión

CPU de la serie AMD Ryzen (Matisse, Summit Ridge y Pinnacle Ridge)

- 1 x ranura PCI Express 3.0 x16 (PCIe2:modo x16)*

CPU de la serie AMD Ryzen (Picasso, Raven Ridge)

- 1 x ranura PCI Express 3.0 x16 (PCIe2:modo x8)*

CPU de la serie AMD Athlon

- 1 x ranura PCI Express 3.0 x16 (PCIe2:modo x4)*

* Admite unidad de estado sólido de NVMe como disco de arranque

- 1 x ranura PCI Express 2.0 x1

Gráficos

- Tarjeta gráfica de la serie AMD Radeon™ Vega integrada en APU de la serie Ryzen*
- * El soporte real puede variar según la CPU
- DirectX 12, Pixel Shader 5.0
- Memoria compartida predeterminada de 2 GB; la memoria máxima compartida admite hasta 16 GB.
- * La memoria compartida máxima de 16 GB requiere que haya una memoria del sistema de 32 GB instalada.
- Tres opciones de salida de gráficos: D-Sub, DVI-D y HDMI
- Compatible con tres monitores
- Admite la tecnología HDMI 1.4 con una resolución máxima de 4K x 2K (4096x2160) @ 24Hz / (3840x2160) @ 30Hz
- Compatible con DVI-D con máxima resolución hasta 1920x1200 @ 60Hz
- Admite D-Sub con una resolución máxima de 2048x1536 @ 60 Hz
- Admite Sincronización automática entre audio y vídeo, color profundo (12 bpc), xvYCC y HBR (audio de alta tasa de bits) con puerto HDMI 1.4 (se necesita un monitor compatible con HDMI)
- Compatible con función HDCP 1.4 con puertos DVI-D y HDMI 1.4
- Admite reproducción 4K Ultra HD (UHD) con puerto HDMI 1.4

Audio

- 7.1 Audio CH HD (Código de audio Realtek ALC887/897)
- Admite protección contra sobretensiones

LAN

- PCIE x1 Gigabit LAN 10/100/1000 Mb/s
- Realtek RTL8111H
- Admite la función Reactivación de LAN
- Admite protección contra rayos y descargas electrostáticas (ESD)
- Admite Ethernet 802.3az de eficiencia energética
- Admite PXE

E/S en panel posterior

- 1 x puerto de ratón/teclado PS/2
- 1 x puerto D-Sub
- 1 x puerto DVI-D
- 1 x puerto HDMI
- 2 x Puertos USB 2.0 (admite protección contra descargas electrostáticas)
- 4 x Puertos USB 3.2 Gen1 (admite protección contra descargas electrostáticas)
- 1 x Puerto LAN RJ-45 con LED (LED DE ACTIVIDAD/ENLACE y LED DE VELOCIDAD)

- Conector de audio HD: Entrada de línea / Altavoz frontal / Micrófono

Almacenamiento

- 4 x conectores SATA3 de 6,0 Gb/s, compatible con RAID (RAID 0, RAID 1 y RAID 10), NCQ, AHCI y conexión en caliente
- 1 x Zócalo Ultra M.2 que admite el módulo SATA3 6,0 Gb/s M.2 de tipo 2242/2260/2280 con clave M y el módulo PCI Express M.2 hasta Gen3 x4 (32 Gb/s) (con Matisse, Picasso, Summit Ridge, Raven Ridge y Pinnacle Ridge) o Gen3 x2 (16 Gb/s) (con APU Athlon serie)*

* Admite unidad de estado sólido de NVMe como disco de arranque

* Admite el Kit U.2 de ASRock

Conector

- 1 x Base de conexiones de puerto COM
- 1 x Conector TPM
- 1 x cabezal de intrusión de chasis y de altavoces
- 1 x Conector para ventilador de la CPU (4 contactos)
- * El conector para ventilador de la CPU admite ventilador de la CPU con una potencia de ventilador de 1 A (12 W) máxima.
- 2 x conectores de ventilador del chasis (1 de 4 pines y 1 de 3 pines)
- * El conector para ventilador de la CPU admite ventilador de la CPU con una potencia de ventilador de 1 A (12 W) máxima.
- 1 x conector de alimentación ATX de 24 contactos
- 1 x conector de alimentación de 12V de 4 contactos
- 1 x Conector de audio en el panel frontal
- 2 x Bases de conexiones USB 2.0 (admite 4 puertos USB 2.0) (Admite protección contra descargas electrostáticas)
- 1 x base de conexiones USB 3.2 Gen1 (admite 2 puertos USB 3.2 Gen1) (Admite protección contra descargas electrostáticas)

SO

- Microsoft® Windows® 10 64 bits

Технические характеристики

Платформа

- Форм-фактор Micro ATX
- Схема на основе твердотельных конденсаторов

ЦП

- AMD сокет AM4
- Система питания 6

Чипсет

- AMD Promontory B450

Память

- Двухканальная память DDR4
- 2 гнезда DDR4 DIMM
- Процессоры AMD серии Ryzen (Matisse) поддерживают модули памяти DDR4 3200/2933/2667/2400/2133, ECC, non-ECC и Unbuffered*
- Процессоры AMD серии Ryzen (Pinnacle Ridge) поддерживают модули памяти DDR4 3200+(OC)/2933 (OC)/2667/2400/2133, ECC, non-ECC и Unbuffered*
- Процессоры AMD серии Ryzen (Picasso) поддерживают модули памяти DDR4 2933/2667/2400/2133, ECC, non-ECC и Unbuffered*
- Процессоры AMD серии Ryzen (Summit Ridge) поддерживают модули памяти DDR4 3200+(OC)/2933 (OC)/2667/2400/2133, ECC, non-ECC и Unbuffered*
- Процессоры AMD серии Ryzen (Raven Ridge) поддерживают модули памяти DDR4 3200+(OC)/2933/2667/2400/2133, non-ECC и Unbuffered*

*Для процессоров серии Ryzen (Picasso и Raven Ridge) модуль памяти ECC поддерживается только процессорами PRO.

* Дополнительная информация представлена в Списке совместимой памяти (Memory Support List) на веб-сайте ASRock. (<http://www.asrock.com/>)

* Сведения о поддержке частоты памяти AMD (не XMP) представлены в таблице на стр. 10. С подробной информацией можно ознакомиться в разделе QVL на веб-сайте ASRock.

- Максимальный объем ОЗУ: 32 Гб
- Поддержка модулей памяти XMP (Extreme Memory Profile)
- Позолоченные (15 мкм) контакты слотов DIMM

Слоты расширения

ЦП серии AMD Ryzen (Matisse, Summit Ridge и Pinnacle Ridge)

- 1 слот PCI Express 3.0 x16 (PCIЕ2:режим x16)*

ЦП серии AMD Ryzen (Picasso, Raven Ridge)

- 1 слот PCI Express 3.0 x16 (PCIЕ2:режим x8)*

ЦП серии AMD Athlon

- 1 слот PCI Express 3.0 x16 (PCIЕ2:режим x4)*

* Поддерживаются в качестве загрузочных SSD-диски типа NVMe.

- 1 слот PCI Express 2.0 x1

Графическая подсистема

- Встроенный видеоадаптер AMD Radeon™ серии Vega в процессорах APU серии Ryzen*

*Фактическая поддержка зависит от процессора

- DirectX 12, пиксельные шейдеры 5.0
- Общий объем памяти по умолчанию 2 ГБ, поддерживается максимальный общий объем памяти до 16 ГБ.

* Для максимального общего объема памяти 16 ГБ требуется установить системную память емкостью 32 ГБ.

- Три видеовыхода: D-Sub, DVI-D и HDMI
- Поддержка работы с тремя мониторами
- Поддерживается HDMI 1.4 с максимальным разрешением до 4К x 2К (4096x2160) при частоте обновления 24 Гц (3840x2160 при 30 Гц)
- На выходе DVI-D поддерживается максимальное разрешение до 1920x1200 при частоте обновления 60 Гц
- Макс. разрешение на выходе D-Sub: 2048x1536 при частоте обновления 60 Гц
- Поддерживаются Auto Lip Sync, Deep Color (12 бит/цвет), xvYCC и HBR (High Bit Rate Audio) через порт HDMI 1.4 (требуется соответствующий HDMI-монитор)
- Поддержка функции HDCP 1.4 через порты DVI-D и HDMI 1.4
- Поддержка вывода видео с разрешением 4K Ultra HD (UHD) на порт HDMI 1.4

Звук

- 7.1-канальный звук высокой четкости (аудиокодек Realtek ALC887/897)
- Защита от перепадов напряжения в электрической сети

LAN

- PCIe x1 Gigabit LAN 10/100/1000 Мбит/с
- Realtek RTL8111H
- Поддерживается пробуждение по ЛВС
- Молниезащита и защита от электростатических разрядов
- Поддерживается Energy Efficient Ethernet 802.3az
- Поддерживается PXE

Порты ввода-вывода на задней панели

- 1 порт PS/2 для мыши/клавиатуры
- 1 порт D-Sub
- 1 порт DVI-D
- 1 порт HDMI
- 2 порта USB 2.0 (с защитой от электростатических разрядов)
- 4 портов USB 3.2 Gen1 (с защитой от электростатических разрядов)

- 1 порт ЛВС RJ-45 с индикаторами («Активность/Соединение» и «Скорость»)
- Разъемы HD Audio: линейный вход / фронтальные AC / микрофон

Запоминающие устройства

- 4 порта SATA3 со скоростью передачи данных 6,0 Гб/с, поддержка RAID (RAID 0, RAID 1 и RAID 10), NCQ, AHCI и «горячего подключения».
- 1 слот Ultra M.2, поддерживает модуль M.2 SATA3 типа 2242/2260/2280 со скоростью обмена данными 6,0 Гбит/с с ключом M и модуль M.2 PCI Express до версии Gen3 x4 (32 Гбит/с) (с Matisse, Picasso, Summit Ridge, Raven Ridge и Pinnacle Ridge) или Gen3 x2 (16 Гбит/с) (с Athlon серии APU)*

* Поддерживаются в качестве загрузочных SSD-диски типа NVMe.

* Поддерживается комплект ASRock U.2

Разъемы

- 1 колодка COM-порта
- 1 колодка TPM
- 1 колодка с разъемами датчика вскрытия корпуса и динамика
- 1 разъем для вентилятора охлаждения ЦП, 4-контактный

* Разъем процессорного вентилятора поддерживает вентилятор с потребляемым током не более 1 А (12 Вт).

- 2 разъема для корпусного вентилятора (1 разъем 4-контактный, 1 разъем 3-контактный)

* Разъем процессорного вентилятора поддерживает вентилятор с потребляемым током не более 1 А (12 Вт).

- 1 разъем питания ATX, 24-контактный
- 1 разъем питания 12 В, 4-контактный
- 1 аудиоразъем для передней панели
- 2 колодки USB 2.0 (4 порта USB 2.0, с защитой от электростатических разрядов)
- 1 колодка USB 3.2 Gen1 (2 порта USB 3.2 Gen1) (с защитой от электростатических разрядов)

Операционные системы

- Microsoft® Windows® 10 (64-разрядная)

Especificações

- Plataforma**
- Micro ATX Form Factor
 - Design de condensador sólido

- CPU**
- Soquete AMD AM4
 - Design com 6 fases de alimentação

- Chipset**
- AMD Promontory B450

- Memória**
- Tecnologia de memória DDR4 de dois canais
 - 2 x Slots DIMM DDR4
 - CPUs série AMD (Matisse) suporta DDR4 3200/2933/2667/2400/2133 ECC & não-ECC, memória un-buffered*
 - CPUs série AMD Ryzen (Pinnacle Ridge) suporta DDR4 3200+(OC)/2933(OC)/2667/2400/2133 ECC & não-ECC, memória un-buffered*
 - CPUs série AMD (Picasso) suporta DDR4 2933/2667/2400/2133 ECC & não-ECC, memória un-buffered*
 - CPUs série AMD Ryzen (Summit Ridge) suporta DDR4 3200+(OC)/2933(OC)/2667/2400/2133 ECC & não-ECC, memória un-buffered*
 - CPUs série AMD Ryzen (Raven Ridge) suporta DDR4 3200+(OC)/2933/2667/2400/2133 não-ECC, memória un-buffered*

* Para CPUs série Ryzen (Picasso e Raven Ridge), ECC só é suportado com CPUs PRO.

* Por favor, consulte a Lista de Suporte de Memória no site da ASRock para obter mais informação. (<http://www.asrock.com/>)

* Por favor, consulte a página 10 para a tabela para suporte de frequência de memória AMD não XMP. Para mais detalhes, consulte o QVL no website da ASRock.

- Capacidade máxima da memória do sistema: 32GB
- Suporta módulos de memória Extreme Memory Profile (XMP)
- Contato em Ouro 15µ nos slots DIMM

Slot de expansão

CPUs AMD Série Ryzen (Summit Ridge e Pinnacle Ridge)

- 1 x Slot PCI Express 3.0 x16 (PCIE2:modo x16)*

CPUs AMD Série Ryzen (Raven Ridge)

- 1 x Slot PCI Express 3.0 x16 (PCIE2:modo x8)*

CPUs AMD Série Athlon

- 1 x Slot PCI Express 3.0 x16 (PCIE2:modo x4)*

* Suporta NVMe SSD nos discos de inicialização

- 1 x slots PCI Express 2.0 x1

Gráficos

- AMD Radeon™ Integrado Série Vega Gráficas na Série Ryzen APU*
- * Suporte atual pode variar por CPU
- DirectX 12, Pixel Shader 5.0
- Memória compartilhada padrão 2GB, memória compartilhada máx suporta até 16GB.
- * A memória compartilhada máx de 16GB requer 32 GB de memória de sistema instalado.
- Três opções de saída de gráficos: D-Sub, DVI-D e HDMI
- Suporta configuração com três monitores
- Suporta HDMI 1.4 com resolução máx. até 4K x 2K (4096x2160) @ 24Hz / (3840x2160) @ 30Hz
- Suporta DVI-D com resolução máxima de até 1920x1200 @ 60Hz
- Suporta D-Sub com resolução máxima de até 2048x1536 @ 60Hz
- Suporta Auto sincronização labial, Deep Color (12bpc), xvYCC e HBR (High Bit Rate Audio) com porta HDMI 1.4 (É necessário um monitor compatível com HDMI)
- Suporta HDCP 1.4 com Portas DVI-D e HDMI 1.4
- Suporta reprodução HD Ultra (UHD) 4K com Porta HDMI 1.4

Áudio

- Áudio 7.1 CH HD com proteção de conteúdo (Codec de áudio Realtek ALC887/897)
- Suporta Proteção de Sobre-tensão

LAN

- LAN Gigabit 10/100/1000 Mb/s PCIE x1
- Realtek RTL8111H
- Suporta Wake-On-LAN
- Oferece Suporte à Proteção de Relâmpago/ESD
- Suporta Energy Efficient Ethernet 802.3az
- Suporta PXE

E/S do painel posterior

- 1 x Porta PS/2 para mouse/teclado
- 1 x Porta D-Sub
- 1 x Porta DVI-D
- 1 x Porta HDMI
- 2 x Portas USB 2.0 (Suporta Proteção ESD)
- 4 x Portas USB 3.2 Gen1 (Suporta Proteção ESD)
- 1 x Porta LAN RJ-45 com LED (LED ACT/LINK e LED DE VELOCIDADE)
- Fichas de áudio HD: Entrada de Linha / Autofalante Frontal / Microfone

**Armazena-
mento**

- 4 x Conectores SATA3 6,0 Gb/s, suporta RAID (RAID 0, RAID 1, e RAID 10), NCQ, AHCI e Conexão a Quente
- 1 x Soquete Ultra M.2, suporta M chave digite 2242/2260/2280 módulo M.2 SATA3 6,0 Gb/s e M.2 PCI Express até Gen3 x4 (32 Gb/s) (ccom Matisse, Picasso, Summit Ridge, Raven Ridge e Pinnacle Ridge) ou Gen3 x2 (16 Gb/s) (com Athlon Série APU)*

* Suporta NVMe SSD nos discos de inicialização

* Suporta Kit U.2 ASRock

Conector

- 1 x Suporte porta COM
- 1 x Plataforma TPM
- 1 x Intrusão do Chassi e Cabeçote de Autofalante
- 1 x Conector da ventoinha da CPU (4 pinos)

* O Conector do Ventilador de CPU suporta o ventilador de CPU de alimentação máxima 1A do ventilador (12W).

- 2 x Conectores ventilador chassis (1 x 4 pinos, 1 x 3 pinos)

* O Conector do Ventilador de CPU suporta o ventilador de CPU de alimentação máxima 1A do ventilador (12W).

- 1 x Conector alimentação ATX 24 pinos
- 1 x Conector de energia 4-pinos 12V
- 1 x Conector de áudio do painel frontal
- 2 x Plataformas USB 2.0 (Suporta 4 portas USB 2.0) (Suporta Proteção ESD)
- 1 x Plataforma USB 3.2 Gen1 (Suporta 2 portas USB 3.2 Gen1) (Suporta Proteção ESD)

SO

- Microsoft® Windows® 10 64-bit

Specyfikacje

Platforma

- Współczynnik kształtu Micro ATX
- Konstrukcja kondensatorami stałymi

CPU

- AMD AM4 Socket
- Sekcja zasilania 6 Power Phase Design

Chipset

- AMD Promontory B450

Pamięć

- Technologia pamięci Dual Channel DDR4
- 2 x gniazda DDR4 DIMM
- Seria CPU AMD Ryzen (Matisse) z obsługą DDR4 3200/2933/2667/2400/2133 ECC i nie-ECC, pamięć niebuforowana*
- Seria CPU AMD Ryzen (Pinnacle Ridge) z obsługą DDR4 3200+(OC)/2933(OC)/2667/2400/2133 ECC i nie-ECC, pamięć niebuforowana*
- Seria CPU AMD Ryzen (Picasso) z obsługą DDR4 2933/2667/2400/2133 ECC i nie-ECC, pamięć niebuforowana*
- Seria CPU AMD Ryzen (Summit Ridge) z obsługą DDR4 3200+(OC)/2933(OC)/2667/2400/2133 ECC i nie-ECC, pamięć niebuforowana*
- Seria CPU AMD Ryzen (Raven Ridge) z obsługą DDR4 3200+(OC)/2933/2667/2400/2133 nie-ECC, pamięć niebuforowana*

* Dla serii CPU Ryzen (Picasso i Raven Ridge), ECC jest obsługiwana tylko z CPU PRO.

* Sprawdź listę obsługiwaną pamięci na stronie internetowej ASRock w celu uzyskania dalszych informacji.
(<http://www.asrock.com/>)

* Patrz tabela obsługi częstotliwości dla pamięci non-XMP AMD znajdująca się na stronie 10. Dodatkowe informacje można znaleźć w QVL na portalu internetowym ASRock.

- Maks. wielkość pamięci systemowej: 32GB
- Obsługa modułów pamięci Extreme Memory Profile (XMP)
- 15µm pozłacane styki w gniazdach DIMM

Gniazdo rozszerzenia

Procesor serii AMD Ryzen (Summit Ridge oraz Pinnacle Ridge)

- 1 x gniazdo PCI Express 3.0 x 16 (tryb PCIe2:x16)*

Procesor serii AMD Ryzen (Raven Ridge)

- 1 x gniazdo PCI Express 3.0 x 16 (tryb PCIe2:x8)*

Procesor serii AMD Athlon

- 1 x gniazdo PCI Express 3.0 x 16 (tryb PCIe2:x4)*

* Obsługa SSD NVMe, jako dysków rozruchowych

- 1 x gniazdo PCI Express 2.0 x1

Grafika

- Zintegrowana karta graficzna AMD Radeon™ serii Vega w APU serii Ryzen*

* Rzeczywista obsługa zależy od CPU

- Pamięć współdzielona, domyślnie 2GB, Maksymalnie pamięć współdzielona obsługuje do 16GB.

* Maksymalna pamięć współdzielona 16 GB wymaga zainstalowania 32 GB pamięci systemowej.

- Maks. współdzielona pamięć 2GB
- Opcje trzech wyjść graficznych: D-Sub, DVI-D i HDMI
- Obsługa trzech monitorów
- Obsługa HDMI 1.4 z maks. rozdzielczością do 4K x 2K (4096x2160) przy 24Hz / (3840x2160) przy 30Hz
- Obsługa DVI-D z maks. rozdzielczością do 1920x1200 przy 60Hz
- Obsługa D-Sub z maks. rozdzielczością do 2048x1536 przy 60Hz
- Obsługa Auto Lip Sync, Deep Color (12bpc), xvYCC i HBR (High Bit Rate Audio) z portami HDMI 1.4 (Wymagany monitor zgodny z HDMI)
- Obsługa HDCP 1.4 z portami DVI-D i HDMI 1.4
- Obsługa odtwarzania 4K Ultra HD (UHD) z portem HDMI 1.4

Audio

- Dźwięk HD 7.1 CH (kodek audio Realtek ALC887/897)
- Obsługa zabezpieczenia przed przepięciami

LAN

- 1 x PCIe Gigabit LAN 10/100/1000 Mb/s
- Realtek RTL8111H
- Obsługa Wake-On-LAN
- Obsługa zabezpieczenia przed wyładowaniami atmosferycznymi/ESD
- Obsługa Energy Efficient Ethernet 802.3az
- Obsługa PXE

Tylny panel**Wejścia/Wyjścia**

- 1 x port myszy/klawiatury PS/2
- 1 x port D-Sub
- 1 x port DVI-D
- 1 x port HDMI
- 2 x porty USB 2.0 (Obsługa zabezpieczenia ESD)
- 4 x porty USB 3.2 Gen1 (Obsługa zabezpieczenia ESD)
- 1 x porty LAN RJ-45 z LED (LED ACT/LINK i LED SPEED)
- Gniazda audio HD: Wejście liniowe / Głośnik przedni / Mikrofon

Przechowywanie

- 4 x złącza SATA3 6,0 Gb/s, obsługa RAID (RAID 0, RAID 1 i RAID 10), NCQ, AHCI i Hot Plug
- 1 x gniazdo Ultra M.2, obsługa M Key typu 2242/2260/2280 modułu M.2 SATA3 6,0 Gb/s i modułu M.2 PCI Express do Gen3 x4 (32 Gb/s) (z Matisse, Picasso, Summit Ridge, Raven Ridge oraz Pinnacle Ridge) lub Gen3 x2 (16 Gb/s) (z Athlon serii APU)*
- * Obsługa SSD NVMe, jako dysków rozruchowych
- * Obsługa ASRock U.2 Kit

Złącze

- 1 x złącze główkowe portu COM
- 1 x złącze główkowe TPM
- 1 x złącze główkowe naruszenia obudowy i głośnika
- 1 x złącze wentylatora CPU (4-pinowe)
- * Złącze wentylatora CPU obsługuje wentylator CPU maksymalnym prądem zasilania wentylatora 1A (12W).
- 2 x złącze wentylatora obudowy (1 x 4-pinowe, 1 x 3-pinowe)
- * Złącze wentylatora CPU obsługuje wentylator CPU maksymalnym prądem zasilania wentylatora 1A (12W).
- 1 x 24 pinowe złącze zasilania ATX
- 1 x 4 pinowe złącze zasilania 12 V
- 1 x złącze audio na panelu przednim
- 2 x złącza główkowe USB 2.0 (Obsługa 4 portów USB 2.0) (Obsługa zabezpieczenia ESD)
- 1 x porty główkowe USB 3.2 Gen1 (obsługa 2 portów USB 3.2 Gen1) (obsługa zabezpieczenia ESD)

System operacyjny

- Microsoft® Windows® 10 64-bitowy

규격

플랫폼

- Micro ATX 폼 팩터
- 솔리드 콘덴서 구조

CPU

- AMD AM4 Socket
- 6 개 전원 위상 구조

칩세트

- AMD Promontory B450

메모리

- 듀얼 채널 DDR4 메모리 기술
- DDR4 DIMM 슬롯 2 개
- AMD Ryzen 시리즈 CPU(Matisse) 는 DDR4 3200/2933/2667/2400/2133 ECC 및 비 ECC, 비버퍼링 메모리를 지원합니다.*
- AMD Ryzen 시리즈 CPU(Pinnacle Ridge) 는 DDR4 3200+(OC)/2933(OC)/2667/2400/2133 ECC 및 비 ECC, 비버퍼링 메모리를 지원합니다.*
- AMD Ryzen 시리즈 CPU(Picasso) 는 DDR4 2933/2667/2400/2133 ECC 및 비 ECC, 비버퍼링 메모리를 지원합니다.*
- AMD Ryzen 시리즈 CPU(Summit Ridge) 는 DDR4 3200+(OC)/2933(OC)/2667/2400/2133 ECC 및 비 ECC, 비버퍼링 메모리를 지원합니다.*
- AMD Ryzen 시리즈 CPU(Raven Ridge) 는 DDR4 3200+(OC)/2933/2667/2400/2133 비 ECC, 비버퍼링 메모리를 지원합니다.*

* Ryzen Series CPU(Picasso 및 Raven Ridge) 의 경우, ECC 는 PRO CPU 에서만 지원합니다.

* 추가 정보를 원하시면 ASRock 웹사이트에 있는 메모리 지원 목록을 참조하십시오. (<http://www.asrock.com/>)

* AMD 비-XMP 메모리 주파수 지원에 대한 표는 10 페이지를 참조하고, 더 자세한 내용은 ASRock 웹사이트의 QVL 을 참조하십시오.

- 시스템 메모리 최대 용량 : 32GB
- Extreme Memory Profile(XMP) 메모리 모듈 지원
- DIMM 슬롯에 15 Gold Contact 장착

확장 슬롯

AMD Ryzen 시리즈 CPU(Matisse, Summit Ridge 및 Pinnacle Ridge)

- PCI Express 3.0 x16 슬롯 1 개 (PCIe2:x16 모드)*

AMD Ryzen 시리즈 CPU(Picasso, Raven Ridge)

- PCI Express 3.0 x16 슬롯 1 개 (PCIe2:x8 모드)*

AMD Athlon 시리즈 CPU

- PCI Express 3.0 x16 슬롯 1 개 (PCIe2:x4 모드)*

- * NVMe SSD 를 부팅 디스크로 사용 가능하도록 지원
- PCI Express 2.0 x1 슬롯 1 개

그래픽

- Ryzen Series APU 의 통합형 AMD Radeon™ Vega Series 그 래픽 *
- * 실제 지원은 CPU 에 따라 다를 수 있음
- DirectX 12, Pixel Shader 5.0
- 기본 공유 메모리는 2GB 이며 최대 공유 메모리는 16GB 까 지 지원됩니다 .
- * 최대 공유 메모리로 16 GB 를 사용하려면 32 GB 의 시스템 메모리가 설치되어 있어야 합니다 .
- 그래픽 출력 옵션 세 개 : D-Sub, DVI-D 및 HDMI
- 삼중 모니터 지원
- HDMI 1.4 지원 (최대 해상도 4K x 2K (4096x2160) @ 24Hz / (3840x2160) @ 30Hz)
- DVI-D 지원 (최대 해상도 1920x1200 @ 60Hz)
- D-Sub 지원 (최대 해상도 2048x1536 @ 60Hz)
- Auto Lip Sync, Deep Color (12bpc), xvYCC 및 HBR (High Bit Rate Audio)(HDMI 1.4 포트 포함) 지원 (HDMI 호환 모니터 필요)
- DVI-D 및 HDMI 1.4 포트를 이용한 HDCP 1.4 지원
- HDMI 1.4 포트를 이용한 4K Ultra HD(UHD) 재생 지원

오디오

- 7.1 CH HD 오디오 (Realtek ALC887/897 오디오 코덱)
- 서비 보호 지원

LAN

- PCIE 1 개 , Gigabit LAN 10/100/1000 Mb/s
- Realtek RTL8111H
- Wake-On-LAN 지원
- 번개 /ESD 보호 지원
- 절전형 이더넷 802.3az 지원
- PXE 지원

후면 패널 I/O

- PS/2 마우스 / 키보드 포트 1 개
- D-Sub 포트 1 개
- DVI-D 포트 1 개
- HDMI 포트 1 개
- USB 2.0 포트 2 개 (ESD 보호 지원)
- USB 3.2 Gen1 포트 4 개 (ESD 보호 지원)
- LED 장착 RJ-45 LAN 포트 1 개 (ACT/LINK LED 및 SPEED LED)
- HD 오디오 잭 : 라인 입력 / 전먼 스피커 / 마이크

저장 장치

- SATA3 6.0 Gb/s 커넥터 4 개가 RAID(RAID 0, RAID 1 및 RAID 10), NCQ, AHCI 및 핫 플러그를 지원합니다.
- 울트라 M.2 소켓 1 개, M 키 타입 2242/2260/2280 M.2 SATA3 6.0 Gb/s 모듈 및 Gen3 M.2 PCI Express 모듈 (Matisse, Picasso, Summit Ridge, Raven Ridge, Pinnacle Ridge 의 경우) 을 4 개 (32 Gb/s) 까지 또는 Gen3(Athlon 시리즈 APU 의 경우) 의 경우 2 개 (16 Gb/s) 까지 지원 *

* NVMe SSD 를 부팅 디스크로 사용 가능하도록 지원

* ASRock U.2 키트 지원

커넥터

- COM 포트 헤더 1 개
- TPM 헤더 1 개
- 새시 침입 및 스피커 헤더 1 개
- CPU 팬 커넥터 (4 핀) 1 개

* CPU 팬 커넥터는 팬 전력이 최대 1A(12W) 인 CPU 팬을 지원합니다.

- 새시 팬 커넥터 2 개 (1 x 4 핀, 1 x 3 핀)

* CPU 팬 커넥터는 팬 전력이 최대 1A(12W) 인 CPU 팬을 지원합니다.

- 24 핀 ATX 전원 커넥터 1 개
- 4 핀 12V 전원 커넥터 1 개
- 전면 패널 오디오 커넥터 1 개
- USB 2.0 헤더 2 개 (USB 2.0 포트 4 개 지원) (ESD 보호 지원)
- USB 3.2 Gen1 헤더 1 개 (USB 3.2 Gen1 포트 2 개 지원) (ESD 보호 지원)

OS

- Microsoft® Windows® 10 64- 비트

仕様

プラットフォーム

- マイクロ ATX フォームファクター
- 固体コンデンサ設計

CPU

- AMD AM4 ソケット
- 6 電源フェーズ設計

チップセット

- AMD Promontory B450

メモリ

- デュアルチャンネル DDR4 メモリ機能
- 2 x DDR4 DIMM スロット
- AMD Ryzen シリーズ CPU (Matisse) は、DDR4 3200/2933/2667/2400/2133 ECC および非 ECC、アンバッファードメモリに対応します *
- AMD Ryzen シリーズ CPU (Pinnacle Ridge) は、DDR4 3200+(OC)/2933(OC)/2667/2400/2133 ECC および非 ECC、アンバッファードメモリに対応します *
- AMD Ryzen シリーズ CPU (Picasso) は、DDR4 2933/2667/2400/2133 ECC および非 ECC、アンバッファードメモリに対応します *
- AMD Ryzen シリーズ CPU (Summit Ridge) は、DDR4 3200+(OC)/2933(OC)/2667/2400/2133 ECC および非 ECC、アンバッファードメモリに対応します *
- AMD Ryzen シリーズ CPU (Raven Ridge) は、DDR4 3200+(OC)/2933/2667/2400/2133 非 ECC、アンバッファードメモリに対応します *

* Ryzen シリーズ CPU (Picasso, Raven Ridge) の場合、ECC は PRO CPU のみに対応します。

* 詳細については、ASRock ウェブサイトのメモリーサポート一覧を参照してください。(http://www.asrock.com/)

* AMD の非 XMP メモリ周波数サポートについては、10 ページの表を参照してください。詳細については、ASRock の Web サイトの QVL を参照してください。

- システムメモリの最大容量：32GB
- Extreme Memory Profile (XMP) メモリモジュールに対応します
- DIMM スロットに 15 μ ゴールドコンタクトを採用

拡張スロット

AMD Ryzen シリーズ CPU (Matisse, Summit Ridge および Pinnacle Ridge)

- 1 x PCI Express 3.0 x16 スロット (PCIe2:x16 モード)*

AMD Ryzen シリーズ CPU (Picasso, Raven Ridge)

- 1 x PCI Express 3.0 x16 スロット (PCIe2:x8 モード)*

AMD Athlon シリーズ CPU

- 1 x PCI Express 3.0 x16 スロット (PCIe2:x4 モード)*

* 起動ディスクとして NVMe SSD に対応

- 1 x PCI Express 2.0 x1 スロット

グラフィックス

- AMD Radeon™ Vega シリーズグラフィックスを Ryzen シリーズ APU に統合*
- * 実際のサポートは CPU によって異なることがあります
- DirectX 12, Pixel Shader 5.0
- 共有メモリはデフォルトでは 2GB に設定されています。最大共有メモリは 16GB まで対応します。
- * 最大共有メモリが 16 GB の場合は、32 GB のシステムメモリがインストールされていなければなりません。
- 3 つのグラフィックス出力オプション : D-Sub, DVI-D, HDMI
- 3 台のモニターに対応
- HDMI 1.4 に対応、最大解像度 4K x 2K (4096x2160) @ 24Hz / (3840x2160) @ 30Hz
- DVI-D に対応、最大解像度 1920x1200 @60Hz
- D-Sub をサポート。最大解像度 2048x1536 @60Hz
- HDMI 1.4 ポートでオートリップシンク、ディープカラー (12bpc)、xvYCC、および、HBR (高ビットレートオーディオ) に対応 (HDMI 対応モニターが必要です)
- DVI-D ポートと HDMI 1.4 ポートで HDCP 1.4 に対応
- HDMI 1.4 ポートで 4K Ultra HD (UHD) 再生に対応

オーディオ

- 7.1 CH HD オーディオ (Realtek ALC887/897 Audio Codec)
- サージ保護に対応

LAN

- PCIE x1 ギガビット LAN 10/100/1000 Mb/ 秒
- Realtek RTL8111H
- Wake-On-LAN (ウェイク オン ラン) に対応
- 雷 / 静電気放電 (ESD) 保護に対応
- エネルギー効率のよいイーサネット 802.3az をサポート
- PXE をサポート

リアパネル I/O

- 1 x PS/2 マウス / キーボードポート
- 1 x D-Sub ポート
- 1 x DVI-D ポート
- 1 x HDMI ポート
- 2 x USB 2.0 ポート (静電気放電 (ESD) 保護に対応)
- 4 x USB 3.2 Gen1 ポート (静電気放電 (ESD) 保護に対応)
- LED 付き 1 x RJ-45 LAN ポート (ACT/LINK LED と SPEED LED)
- HD オーディオジャック : ラインイン / フロントスピーカー / マイク

ストレージ

- 4 x SATA3 6.0 Gb/s コネクタ、RAID(RAID 0、RAID 1、RAID 10)、NCQ、AHCI およびホットプラグ機能に対応
- 1 x ウルトラ M.2 ソケット、M Key タイプ 2242/2260/2280 M.2 SATA3 6.0 Gb/s モジュール、および、最大 Gen3 x4 (32 Gb/s) (Matisse、Picasso、Summit Ridge、Raven Ridge、および、Pinnacle Ridge が搭載されている場合)または最大 Gen3 x2 (16 Gb/s) (Athlon シリーズ APU が搭載されている場合)までの M.2 PCI Express モジュールに対応 *

* 起動ディスクとして NVMe SSD に対応

* ASRock U.2 キットに対応

コネクタ

- 1 x COM ポートヘッダー
- 1 x TPM ヘッダー
- 1 x シャーシイントルージョンとスピーカーヘッダー
- 1 x CPU ファンコネクタ(4 ピン)

* CPU ファンコネクタは最大 1A (12W) の電力の CPU ファンに対応します。

- 2 x シャーシファンコネクタ(1 x 4 ピン、1 x 3 ピン)

* CPU ファンコネクタは最大 1A (12W) の電力の CPU ファンに対応します。

- 1 x 24 ピン ATX 電源コネクタ
- 1 x 4 ピン 12V 電源コネクタ
- 1 x 前面パネルオーディオコネクタ
- 2 x USB 2.0 ヘッダー(4 つの USB 2.0 ポートに対応)(静電気放電(ESD)保護に対応)
- 1 x USB 3.2 Gen1 ヘッダー(2 つの USB 3.2 Gen1 ポートに対応)(静電気放電(ESD)保護に対応)

OS

- Microsoft® Windows® 10 64-bit



ユーザーマニュアル

规格

- 平台**
- Micro ATX 规格尺寸
 - 稳固的电容器设计

- CPU**
- AMD AM4 Socket
 - 6 电源相设计

- 芯片集**
- AMD Promontory B450

- 内存**
- 双通道 DDR4 内存技术
 - 2 x DDR4 DIMM 槽
 - AMD Ryzen 系列 CPU (Matisse) 支持 DDR4 3200/2933/2667/2400/2133 ECC 及非 ECC，非缓冲内存 *
 - AMD Ryzen 系列 CPU (Pinnacle Ridge) 支持 DDR4 3200+(OC)/2933(OC)/2667/2400/2133 ECC 及非 ECC，非缓冲内存 *
 - AMD Ryzen 系列 CPU (Picasso) 支持 DDR4 2933/2667/2400/2133 ECC 及非 ECC，非缓冲内存 *
 - AMD Ryzen 系列 CPU (Summit Ridge) 支持 DDR4 3200+(OC)/2933(OC)/2667/2400/2133 ECC 及非 ECC，非缓冲内存 *
 - AMD Ryzen 系列 CPU (Raven Ridge) 支持 DDR4 3200+(OC)/2933/2667/2400/2133 及非 ECC，非缓冲内存 *
- * 对于 Ryzen 系列 CPU (Picasso 及 Raven Ridge)，仅 PRO CPU 支持 ECC。
- * 请参阅华擎网站上的 Memory Support List (内存支持列表) 了解详情。(http://www.asrock.com/)
- * 请参考第 10 页的 AMD 非 XMP 内存频率支持表。更多详细信息，请参考 ASRock 网站上的 QVL。
- 支持系统内存最大容量：32GB
 - 支持 Extreme Memory Profile (XMP) 内存模块
 - DIMM 插槽中 15 μ 金触点

- 扩充槽**
- AMD Ryzen 系列 CPU (Summit Ridge 和 Pinnacle Ridge)**
- 1 x PCI Express 3.0 x16 插槽 (PCIe2 : x16 模式) *
- AMD Ryzen 系列 CPU (Raven Ridge)**
- 1 x PCI Express 3.0 x16 插槽 (PCIe2 : x8 模式) *
- AMD Athlon 系列 CPU**
- 1 x PCI Express 3.0 x16 插槽 (PCIe2 : x4 模式) *

- * 支持 NVMe SSD 用作启动盘
- 1 x PCI Express 2.0 x1 槽

图形

- Ryzen 系列 APU 中的集成 AMD Radeon™ Vega 系列图形 *
- * 实际支持可能视 CPU 而变化
- DirectX 12、Pixel Shader 5.0
- 默认共享内存 2GB，最大共享内存达 16GB。
- * 最大共享内存 16 GB 需要安装 32 GB 系统内存。
- 3 个图形输出选项：D-Sub、DVI-D 和 HDMI
- 支持三台显示器
- 支持 HDMI 1.4，24Hz 时最大分辨率可达 4K x 2K (4096x2160)/30Hz 时可达 (3840x2160)
- 支持 DVI-D，60Hz 时最大分辨率达 1920x1200
- 支持 D-Sub，60Hz 时最大分辨率达 2048x1536
- 通过 HDMI 1.4 端口（需要兼容的 HDMI 显示器）支持 Auto Lip Sync、Deep Color (12bpc)，xvYCC 和 HBR（高位速率音频）
- 通过 DVI-D 和 HDMI 1.4 端口支持 HDCP 1.4
- 通过 HDMI 1.4 端口支持 4K 超高清 (UHD) 播放

音频

- 7.1 CH 高清音频 (Realtek ALC887/897 音频编解码器)
- 支持电涌保护

LAN

- PCIe x1 Gigabit LAN 10/100/1000 Mb/s
- Realtek RTL8111H
- 支持 Wake-On-LAN（网上唤醒）
- 支持雷电 /ESD 保护
- 支持高效以太网 802.3az
- 支持 PXE

后面板 I/O

- 1 x PS/2 鼠标 / 键盘端口
- 1 x D-Sub 端口
- 1 x DVI-D 端口
- 1 x HDMI 端口
- 2 x USB 2.0 端口 (支持 ESD 保护)
- 4 x USB 3.2 Gen1 端口 (支持 ESD 保护)
- 1 x RJ-45 LAN 端口，带 LED (ACT/LINK LED 和 SPEED LED)
- 高清音频插孔：线路输入 / 前扬声器 / 麦克风

存储

- 4 x SATA3 6.0 Gb/s 接口，支持 RAID (RAID 0、RAID 1 和 RAID 10)、NCQ、AHCI 和热插拔
- 1 x 超级 M.2 接口，支持 M Key 类型 2242/2260/2280 M.2 SATA3 6.0 Gb/s 类型模块和 M.2 PCI Express 模块（最高 Gen3 x4 (32 Gb/s) (Matisse、Picasso、Summit Ridge、Raven Ridge 和 Pinnacle Ridge) 或 Gen3 x2 (16 Gb/s) (Athlon 系列 APU)）*
- * 支持 NVMe SSD 用作启动盘
- * 支持华擎 U.2 套件

接口

- 1 x COM 端口接头
- 1 x TPM 接脚
- 1 x 机箱侵入和扬声器接脚
- 1 x CPU 风扇接口 (4 针)
- * CPU 风扇接口支持最高 1A (12W) 功率的 CPU 风扇。
- 2 x 机箱风扇接口 (1 x 4 针, 1 x 3 针)
- * CPU 风扇接口支持最高 1A (12W) 功率的 CPU 风扇。
- 1 x 24 针 ATX 电源接口
- 1 x 4 针 12V 电源接口
- 1 x 前面板音频接口
- 2 x USB 2.0 接脚 (支持 4 个 USB 2.0 端口，支持 ESD 保护)
- 1 x USB 3.2 Gen1 接脚 (支持 2 个 USB 3.2 Gen1 端口，支持 ESD 保护)

操作系统

- Microsoft® Windows® 10 64-bit

电子信息产品污染控制标示

依据中国发布的「电子信息产品污染控制管理办法」及 SJ/T 11364-2006「电子信息产品污染控制标示要求」，电子信息产品应进行标示，藉以向消费者揭露产品中含有的有毒有害物质或元素不致发生外泄或突变从而对环境造成污染或对人身、财产造成严重损害的期限。依上述规定，您可于本产品之印刷电路板上看见图一之标示。图一中之数字为产品之环保使用期限。由此可知此主板之环保使用期限为 10 年。



图一

有毒有害物质或元素的名称及含量说明

若您欲了解此产品的有毒有害物质或元素的名称及含量说明，请参照以下表格及说明。

部件名称	有害物质或元素					
	铅 (Pb)	镉 (Cd)	汞 (Hg)	六价铬 (Cr(VI))	多溴联苯 (PBB)	多溴二苯醚 (PBDE)
印刷电路板及电子组件	X	O	O	O	O	O
外部信号连接头及线材	X	O	O	O	O	O

O: 表示该有毒有害物质在该部件所有均质材料中的含量均在 SJ/T 11363-2006 标准规定的限量要求以下。

X: 表示该有毒有害物质至少在该部件的某一均质材料中的含量超出 SJ/T 11363-2006 标准规定的限量要求，然该部件仍符合欧盟指令 2002/95/EC 的规范。

备注: 此产品所标示之环保使用年限，系指在一般正常使用状况下。

規格

平台

- Micro ATX 尺寸
- 固態電容設計

CPU

- AMD AM4 Socket
- 6 電源相位設計

晶片組

- AMD Promontory B450

記憶體

- 雙通道 DDR4 記憶體技術
 - 2 x DDR4 DIMM 插槽
 - AMD Ryzen 系列 CPU (Matisse) 支援 DDR4 3200/2933/2667/2400/2133 ECC & 非 ECC、無緩衝記憶體 *
 - AMD Ryzen 系列 CPU (Pinnacle Ridge) 支援 DDR4 3200+(OC)/2933(OC)/2667/2400/2133 ECC & 非 ECC、無緩衝記憶體 *
 - AMD Ryzen 系列 CPU (Picasso) 支援 DDR4 2933/2667/2400/2133 ECC & 非 ECC、無緩衝記憶體 *
 - AMD Ryzen 系列 CPU (Summit Ridge) 支援 DDR4 3200+(OC)/2933(OC)/2667/2400/2133 ECC & 非 ECC、無緩衝記憶體 *
 - AMD Ryzen 系列 CPU (Raven Ridge) 支援 DDR4 3200+(OC)/2933/2667/2400/2133 非 ECC、無緩衝記憶體 *
- * 若使用 Ryzen 系列 CPU (Picasso 及 Raven Ridge)，僅 PRO CPU 支援 ECC。
- * 如需更多資訊，請參閱華擎網站上的記憶體支援表。(http://www.asrock.com/)
- * 如需 AMD 非 XMP 記憶體頻率支援的資料表，請參閱第 10 頁。如需更詳細的資訊，請參閱 ASRock 網站上的 QVL。
- 最大系統記憶體容量：32GB
 - 支援 Extreme Memory Profile (XMP) 記憶體模組
 - 15 μ 特厚鍍金插槽

擴充插槽

AMD Ryzen 系列 CPU (Summit Ridge 及 Pinnacle Ridge)

- 1 x PCI Express 3.0 x16 插槽 (PCIe2：x16 模式)*

AMD Ryzen 系列 CPU (Raven Ridge)

- 1 x PCI Express 3.0 x16 插槽 (PCIe2：x8 模式)*

AMD Athlon 系列 CPU

- 1 x PCI Express 3.0 x16 插槽 (PCIe2：x4 模式)*

* 支援 NVMe SSD 作為開機磁碟

- 1 x PCI Express 2.0 x1 插槽

顯示卡

- 整合式 AMD Radeon™ Vega Series Graphics 內建於 Ryzen 系列 APU*
- * 實際支援可能隨 CPU 改變
- DirectX 12、Pixel Shader 5.0
- 預設共用記憶體 2GB，最大共用記憶體達 16GB。
- * 最大共用記憶體 16 GB 需要安裝 32 GB 系統記憶體。
- 三個圖形輸出選項：D-Sub、DVI-D 及 HDMI
- 支援三台顯示器
- 支援最高可達 4K x 2K (4096x2160) @ 24Hz / (3840x2160) @ 30Hz 解析度的 HDMI 1.4
- 支援最高可達 1920x1200 @ 60Hz 解析度的 DVI-D
- 最高支援 2048x1536 @ 60Hz 解析度的 D-Sub
- 支援使用 HDMI 1.4 連接埠（需相容於 HDMI 監視器）的 Auto Lip Sync、Deep Color (12bpc)、xvYCC 及 HBR（高位元率音訊）
- 支援含 DVI-D 及 HDMI 1.4 連接埠的 HDCP 1.4
- 支援使用 HDMI 1.4 連接埠進行 4K Ultra HD (UHD) 播放

音訊

- 7.1 CH HD 音訊 (Realtek ALC887/897 音訊轉碼器)
- 支援突波保護

LAN

- PCIe x1 Gigabit LAN 10/100/1000 Mb/s
- Realtek RTL8111H
- 支援網路喚醒
- 支援雷擊／靜電保護
- 支援 802.3az EEE 節能乙太網路
- 支援 PXE

後面板 I/O

- 1 x PS/2 滑鼠／鍵盤連接埠
- 1 x D-Sub 連接埠
- 1 x DVI-D 連接埠
- 1 x HDMI 連接埠
- 2 x USB 2.0 連接埠（支援靜電保護）
- 4 x USB 3.2 Gen1 連接埠（支援靜電保護）
- 1 x RJ-45 LAN 連接埠，含 LED（ACT/LINK LED 及 SPEED LED）
- HD 音訊插孔：線路輸入／前置喇叭／麥克風

儲存裝置

- 提供 4 x SATA3 6.0 Gb/s 接頭，支援 RAID（RAID 0、RAID 1、與 RAID 10）、NCQ、AHCI 及熱插拔
 - 1 x Ultra M.2 插座，支援 M Key 型 2242/2260/2280 M.2 SATA3 6.0 Gb/s 模組與 M.2 PCI Express 模組（最高可達 Gen3 x4 (32 Gb/s)）類型（配備 Matisse、Picasso、Summit Ridge、Raven Ridge 及 Pinnacle Ridge），或使用 Athlon 系列 APU 時，最高可達 Gen3 x2 (16 Gb/s)*
- * 支援 NVMe SSD 作為開機磁碟
* 支持華擎 U.2 套件

接頭

- 1 x COM 連接埠排針
 - 1 x TPM 排針
 - 1 x 機殼防護及喇叭排針
 - 1 x CPU 風扇接頭 (4-pin)
- * CPU 風扇接頭支援最高 1A (12W) 風扇功率的 CPU 風扇。
- 2 x 機殼風扇接頭 (1 x 4-pin、1 x 3-pin)
- * CPU 風扇接頭支援最高 1A (12W) 風扇功率的 CPU 風扇。
- 1 x 24 pin ATX 電源接頭
 - 1 x 4 pin 12V 電源接頭
 - 1 x 前面板音訊接頭
 - 2 x USB 2.0 排針（支援 4 個 USB 2.0 連接埠）（支援靜電保護）
 - 1 x USB 3.2 Gen1 排針（支援 2 個 USB 3.2 Gen1 連接埠）（支援靜電保護）

作業系統

- Microsoft® Windows® 10 64-bit

Spesifikasi

- Platform**
- Bentuk dan Ukuran Micro ATX
 - Desain Kapasitor Solid

- CPU**
- Soket AMD AM4
 - Desain 6 Fase Daya

- Chipset**
- AMD Promontory B450

- Memori**
- Teknologi Memori DDR4 Dua Saluran
 - 2 x Slot DIMM DDR4
 - CPU seri AMD Ryzen (Matisse) mendukung DDR4 3200/2933/2667/2400/2133 ECC & non-ECC, memori tanpa buffer*
 - CPU seri AMD Ryzen (Pinnacle Ridge) mendukung memori tanpa buffer DDR4 3200+(OC)/2933(OC)/2667/2400/2133 ECC & non-ECC*
 - CPU seri AMD Ryzen (Picasso) mendukung DDR4 2933/2667/2400/2133 ECC & non-ECC, memori tanpa buffer*
 - CPU seri AMD Ryzen (Summit Ridge) mendukung memori tanpa buffer DDR4 3200+(OC)/2933(OC)/2667/2400/2133 ECC & non-ECC*
 - CPU seri AMD Ryzen (Raven Ridge) mendukung memori tanpa buffer DDR4 3200+(OC)/2933/2667/2400/2133 non-ECC*
- * Untuk CPU Seri Ryzen (Picasso dan Raven Ridge), ECC hanya didukung dengan CPU PRO.
- * Lihat Daftar Dukungan Memori di situs web ASRock untuk informasi selengkapnya. (<http://www.asrock.com/>)
- * Silakan lihat halaman 10 untuk table dukungan frekuensi memori non-XMP AMD. Untuk rincian selengkapnya, silakan lihat QVI di situs web ASRock.
- Kapasitas maksimum memori sistem: 32GB
 - Mendukung modul memori Extreme Memory Profile (XMP)
 - 15µ Bidang Kontak Berwarna Emas di Slot DIMM

Slot Ekspansi **CPU Seri AMD Ryzen (Summit Ridge, dan Pinnacle Ridge)**

- 1 x Slot PCI Express 3.0 x16 (PCIe2:x16 mode)*

CPU Seri AMD Ryzen (Raven Ridge)

- 1 x Slot PCI Express 3.0 x16 (PCIe2:x8 mode)*

CPU Seri AMD Athlon

- 1 x Slot PCI Express 3.0 x16 (PCIe2:x4 mode)*

* Mendukung SSD NVMe sebagai disk boot

- 1 x Slot PCI Express 2.0 x1

Grafis

- Grafis AMD Radeon™ Terpadu Seri Vega dalam APU Seri Ryzen*
- * Dukungan sebenarnya mungkin beragam berdasarkan CPU
- DirectX 12, Pixel Shader 5.0
- Default memori bersama 2GB, Memori bersama maksimum mendukung hingga 16GB.
- * Memori bersama maksimum 16GB mengharuskan memori sistem 32GB terpasang.
- Tiga pilihan output grafis: D-Sub, DVI-D, dan HDMI
- Mendukung Tiga Monitor
- Mendukung HDMI 1.4 dengan resolusi maksimum hingga 4K x 2K (4096x2160) @ 24Hz/(3840x2160) @ 30Hz
- Mendukung DVI-D dengan resolusi maksimum hingga 1920x1200 @ 60Hz
- Mendukung D-Sub dengan resolusi maksimum hingga 2048x1536 @ 60Hz
- Mendukung Auto Lip Sync, Kedalaman Warna (12bpc), xvYCC, dan HBR (Audio High Bit Rate) dengan Port HDMI 1.4 (memerlukan monitor yang kompatibel dengan HDMI)
- Mendukung HDCP 1.4 dengan port DVI-D dan HDMI 1.4
- Mendukung pemutaran Ultra HD 4K (UHD) dengan Port HDMI 1.4

Audio

- Audio HD 7.1 CH (Realtek ALC887/897 Audio Codec)
- Mendukung Perlindungan dari Lonjakan Arus

LAN

- 1 x PCIE Gigabit LAN 10/100/1000 Mb/s
- Realtek RTL8111H
- Mendukung Wake-On-LAN
- Mendukung Perlindungan dari Petir/ESD
- Mendukung Ethernet 802.3az Hemat Energi
- Mendukung PXE

I/O Panel Belakang

- 1 x Port Mouse/Keyboard PS/2
- 1 x Port D-Sub
- 1 x Port DVI-D
- 1 x Port HDMI
- 2 x Port USB 2.0 (Mendukung Perlindungan dari ESD)
- 4 x Port USB 3.2 Gen1 (Mendukung Perlindungan dari ESD)
- 1 x Port LAN RJ-45 dengan LED (LED ACT/LINK dan LED SPEED)
- Soket Audio HD: Saluran Masuk/Speaker Depan/Mikrofon

Penyimpanan

- 4 x Konektor SATA3 6,0 Gb/s, mendukung RAID (RAID 0, RAID 1, dan RAID 10), NCQ, AHCI dan Hot Plug
- 1 x Soket Ultra M.2, mendukung modul M Key tipe 2242/2260/2280 M.2 SATA3 6,0 Gb/s dan modul M.2 PCI Express hingga Gen3 x4 (32 Gb/s) (dengan Matisse, Picasso, Summit Ridge, Raven Ridge dan Pinnacle Ridge) atau Gen3 x2 (16 Gb/s) (dengan APU seri Athlon)**

* Mendukung SSD NVMe sebagai disk boot

* Mendukung Kit U.2 ASRock

Konektor

- 1 x Header Port COM
- 1 x Header TPM
- 1 x Intrusi Chassis dan Header Speaker
- 1 x Konektor Kipas CPU (4-pin)

* Konektor Kipas CPU mendukung kipas CPU dengan daya kipas maksimum 1A (12W).

- 2 x Konektor Kipas Chassis (1 x 4-pin, 1 x 3-pin)

* Konektor Kipas CPU mendukung kipas CPU dengan daya kipas maksimum 1A (12W).

- 1 x Konektor Daya ATX 24 pin
- 1 x Konektor Daya 4 pin 12V
- 1 x Konektor Audio Panel Depan
- 2 x Header USB 2.0 (Mendukung 4 port USB 2.0) (Mendukung Perlindungan dari ESD)
- 1 x Header USB 3.2 Gen1 (Mendukung 2 port USB 3.2 Gen1) (Mendukung Perlindungan dari ESD)

OS

- Microsoft® Windows® 10 64-bit

Contact Information

If you need to contact ASRock or want to know more about ASRock, you're welcome to visit ASRock's website at <http://www.asrock.com>; or you may contact your dealer for further information. For technical questions, please submit a support request form at <https://event.asrock.com/tsd.asp>

ASRock Incorporation

2F., No.37, Sec. 2, Jhongyang S. Rd., Beitou District,

Taipei City 112, Taiwan (R.O.C.)

ASRock EUROPE B.V.

Bijsterhuizen 11-11

6546 AR Nijmegen

The Netherlands

Phone: +31-24-345-44-33

Fax: +31-24-345-44-38

ASRock America, Inc.

13848 Magnolia Ave, Chino, CA91710

U.S.A.

Phone: +1-909-590-8308

Fax: +1-909-590-1026

DECLARATION OF CONFORMITY

Per FCC Part 2 Section 2.1077(a)



Responsible Party Name: ASRock Incorporation

Address: 13848 Magnolia Ave, Chino, CA91710

Phone/Fax No: +1-909-590-8308/+1-909-590-1026

hereby declares that the product

Product Name : Motherboard

Model Number : B450M-HDV R4.0

Conforms to the following specifications:

FCC Part 15, Subpart B, Unintentional Radiators

Supplementary Information:

This device complies with part 15 of the FCC Rules. Operation is subject to the following two conditions: (1) This device may not cause harmful interference, and (2) this device must accept any interference received, including interference that may cause undesired operation.

Representative Person's Name: James

Signature:

A handwritten signature in black ink, appearing to read 'James', written over a horizontal line.

Date : May 12, 2017

EU Declaration of Conformity



For the following equipment:

Motherboard

(Product Name)

B450M-HDV R4.0 / ASRock

(Model Designation / Trade Name)

ASRock Incorporation

(Manufacturer Name)

2F., No.37, Sec. 2, Jhongyang S. Rd., Beitou District, Taipei City 112, Taiwan (R.O.C.)

(Manufacturer Address)

EMC — Directive 2014/30/EU (from April 20th, 2016)

EN 55022:2010/AC:2011 Class B

EN 55024:2010/A1:2015

EN 55032:2012+AC:2013 Class B

EN 61000-3-3:2013

EN 61000-3-2:2014

LVD — Directive 2014/35/EU (from April 20th, 2016)

EN 60950-1 : 2011+ A2: 2013

EN 60950-1 : 2006/A12: 2011

RoHS — Directive 2011/65/EU

CE marking

(EU conformity marking)



ASRock EUROPE B.V.

(Company Name)

Bijsterhuizen 1111 6546 AR Nijmegen The Netherlands

(Company Address)

Person responsible for making this declaration:

(Name, Surname)

A.V.P

(Position / Title)

December 7, 2018

(Date)

P/N: 15G062133002AK V1.1