



SPARE PARTS EXPLODED VIEW
INSTANTANEOUS GAS WATER HEATERS
Model
FAST R 10 ONM

R8217588-06 - 30/07/2021

FAST R 10 ONM

Instantaneous Gas Water Heaters

1	3632299	FAST R ONM 10 NG	06-2016	-
2	3632311	FAST R ONM 10 NG RU	06-2016	-
3	3632300	FAST R ONM 10 LPG	07-2016	-
3	3510005	FAST R ONM 10 LPG	10-2017	-
Col	Reference	Model type	Begin	End

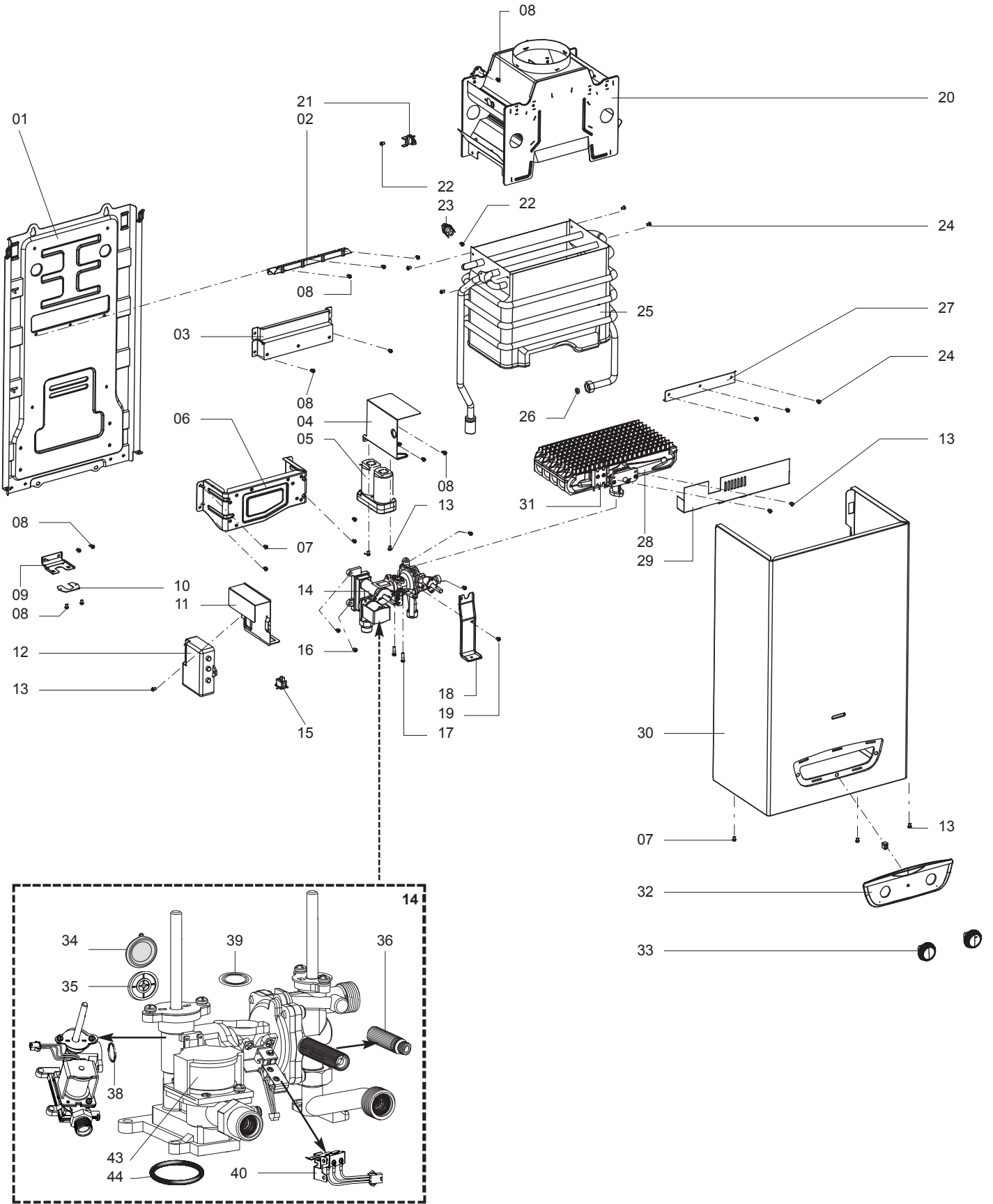

5000

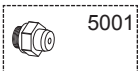

5001

LIST OF THE ABBREVIATIONS

HW	: Hot water.
CW	: Cold water.
C	: Ceramic resistance (normal heating).
Ca	: Ceramic resistance (accelerated heating)
TP	: Immersion heater.
1F	: With fittings.
2F	: Without fittings.
3F	: With fittings and another outlet connection.
AMI	: With mixing valve.
SMI	: Without mixing valve.
PUISS	: Power of th appliance.
PN	: Appliance with normal pression.
LP	: Appliance with low pression.
PV	: Appliance with variable power.
PF	: Appliance with fixed power.

IDENTIFICATION PLATE

SERIAL NUMBER

5 Characters :	FD 8 61	(from 01/98 to 12/99)	Month of manufacture : from 61 to 72 → January to December
			Year of manufacture : 8 → 1998 9 → 1999
OR			
5 Characters :	FD 0 81	(from 01/00)	Month of manufacture : from 81 to 92 → January to December
			Year of manufacture : 0 → 2000 1 → 2001 2 → 2002 etc ...
6 Characters :	FD 83 05		Month of manufacture
			Year of manufacture : 83 → 2003 84 → 2004