

# 301C

User Manual



## **Product Story**

In Win Development Inc. dives into the Mini Tower chassis market with the latest entry to the 300-Series, the 301C. The 301C continues the simple and clean top/front panel interface, while maintaining the LED front I/O.

Accompanied with a toolless, screwless tempered glass side panel, the 301C is quality you can see, feel and experience! Which definitely over your expectation!

# Specifications

<b>Model</b>	301C
<b>Color</b>	Black, White
<b>Case Type</b>	Mini Tower
<b>Case Material</b>	Tempered Glass, SECC
<b>M/B Compatibility</b>	Micro ATX, Mini ITX
<b>Expansion Slots</b>	PCI-E Slot x 4
<b>Maximum Compatibility</b>	<ul style="list-style-type: none"><li>▪ VGA Card Length: 310mm (Height: 162mm)</li><li>▪ VGA Card Length (With Front Fan + Radiator 35mm): 265mm</li><li>▪ CPU Heatsink Height: 158 mm</li></ul>
<b>Front Ports</b>	USB 3.1 Gen 2 Type-C 2 x USB 3.0 HD Audio
<b>Internal Drive Bays</b>	1 x 3.5" / 2.5" 2 x 2.5"
<b>Thermal Solution Compatibility</b>	<ul style="list-style-type: none"><li>▪ 2 x 120mm Front Fan / 240mm Radiator</li><li>▪ 1 x 120mm Rear Fan / 120mm Radiator</li><li>▪ 2 x 120mm Bottom Fan (Occupy a PCI-E slot)</li></ul>
<b>Power Supply Compatibility</b>	PSII: ATX12V - Length up to 160mm
<b>Product Dimension (H x W x D)</b>	365mm x 188mm x 370mm (14.3" x 7.4" x 14.6")
<b>Product Dimension (H x W x D) with screw &amp; handle height</b>	365mm x 208mm x 370mm (14.3" x 8.1" x 14.6")
<b>Package Dimension (H x W x D)</b>	450mm x 272mm x 458mm (17.7"x 10.7"x 18")
<b>Net Weight</b>	6.50KG/ 14.3lb
<b>Gross Weight</b>	7.59KG/ 16.7lb

\* In Win products comply with RoHS regulations

\* Specifications may vary based on different regions

\* Pre-installed glass panel. Extra fee for closed panel

# Package Content



**301C Chassis**



**Accessories Bag**



**QR Code Card**

# Accessories Bag



**X4**

Motherboard Stand-off

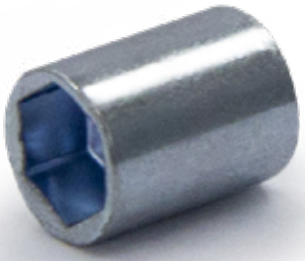

**X1**

Motherboard  
Stand-off Socket



**X15**

Hexagon Head Screws



**X12**

2.5" HDD Screws



**X8**

Water-cooling  
System Washer



**X5**

Cable Tie



**X1**

Graphics Card Holder

# Case Structure

Structure



Tempered Glass



Power Button



Reset Button



HDD/Power LED Indicator

NIM NI

LED Logo



Audio Ports



(Earphone and Microphone)



USB 3.0 Ports



USB 3.1 Gen 2 Type-C

SECC Front / Side Panel



- 1 3.5"/ 2.5" Drive Bay
- 2 2.5" Drive Bay
- 3 Front Fan/ Radiator Mounting Area
- 4 Rear Fan/ Radiator Mounting Area
- 5 Bottom Fan Mounting Area
- 6 Motherboard Mounting Area
- 7 CPU Cooler Installation Cut-Out Hole
- 8 PCI-E Expansion Slot
- 9 Extra PCI-E Supporting Mounting Hole
- 10 Power Supply Mounting Area
- 11 Shock-Proof Stand

# Installation Guide

# 1

## Opening the Chassis

Please remove by pressing the handle on top of tempered glass side panel.



# 2

## Power Supply Installation

Parts Required: Hexagon Head Screws  
Power supply can be mounted on the top bracket



# 3

## Motherboard Installation

Parts Required:  
Motherboard Stand-Off,  
Motherboard Stand-Off Socket,  
Hexagon Head Screws



# 4

## Expansion Card Installation

---

Parts Required:  
Graphics Card Holder,  
Hexagon Head Screws



# 5

## I/O Wires Installation

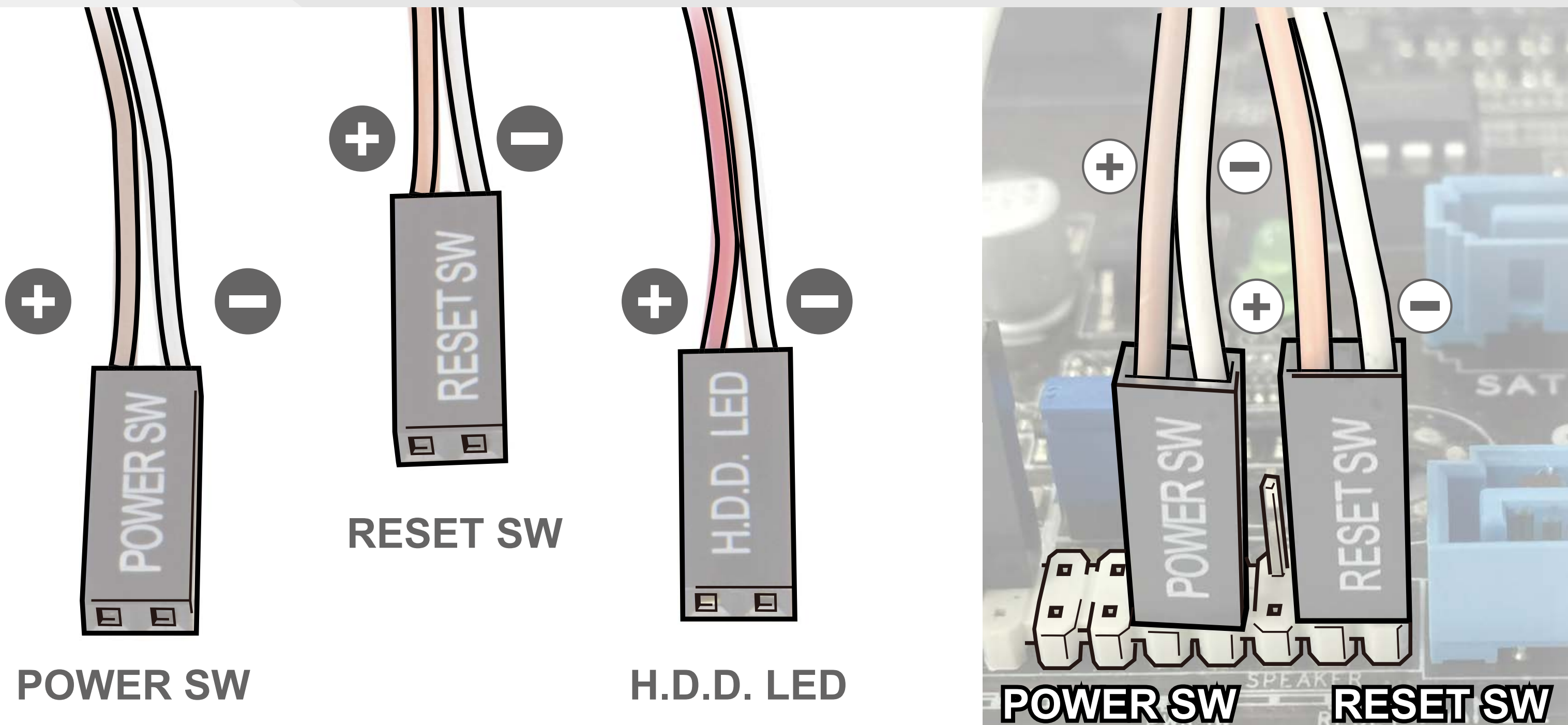

## HD Audio Header

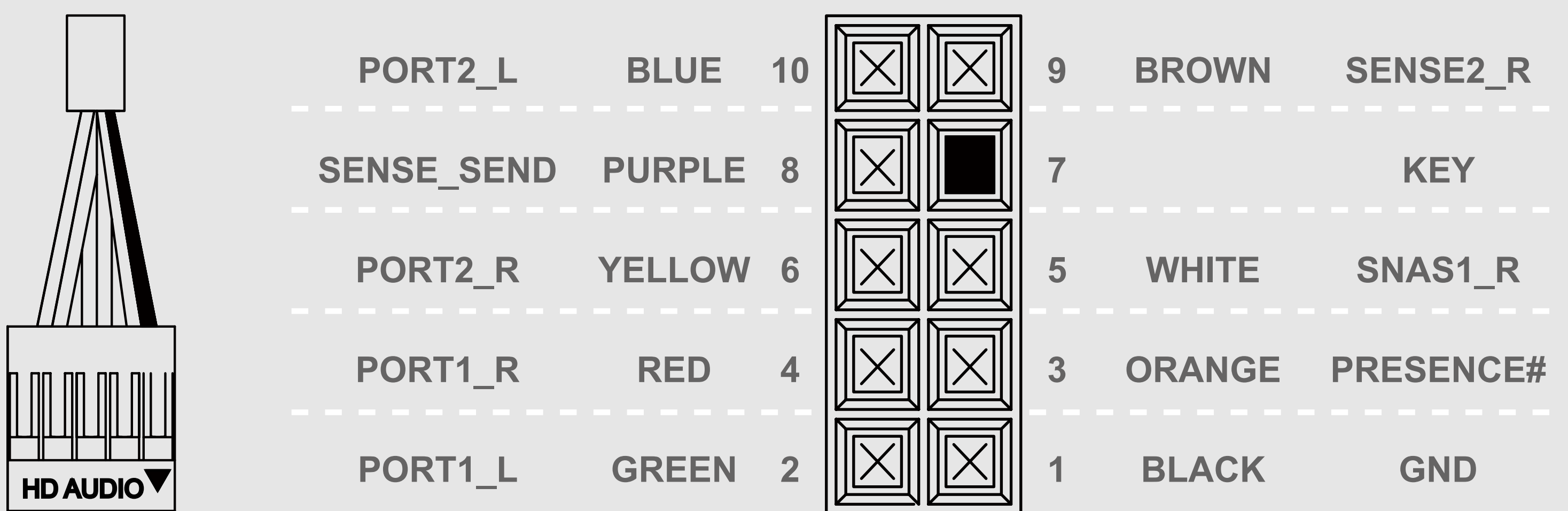

## LED Pipe Power Header

Ensure the beveled edge of the PSU connector is properly aligned with the beveled edge of the LED light connector

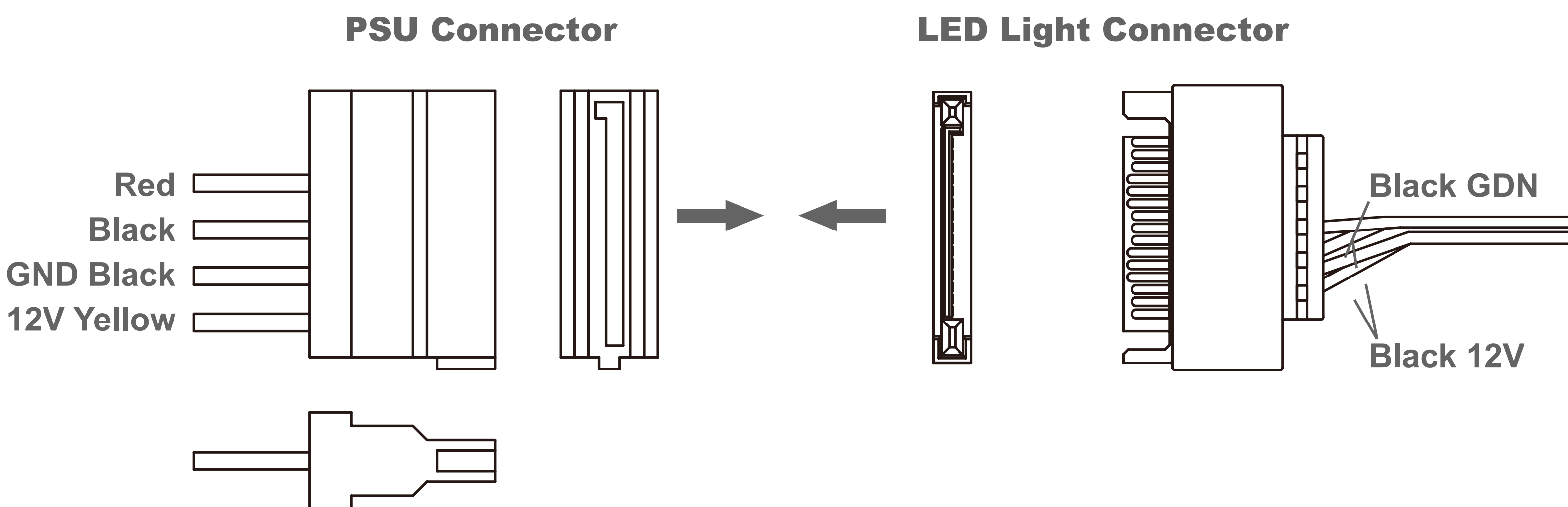

# USB3.0 Header

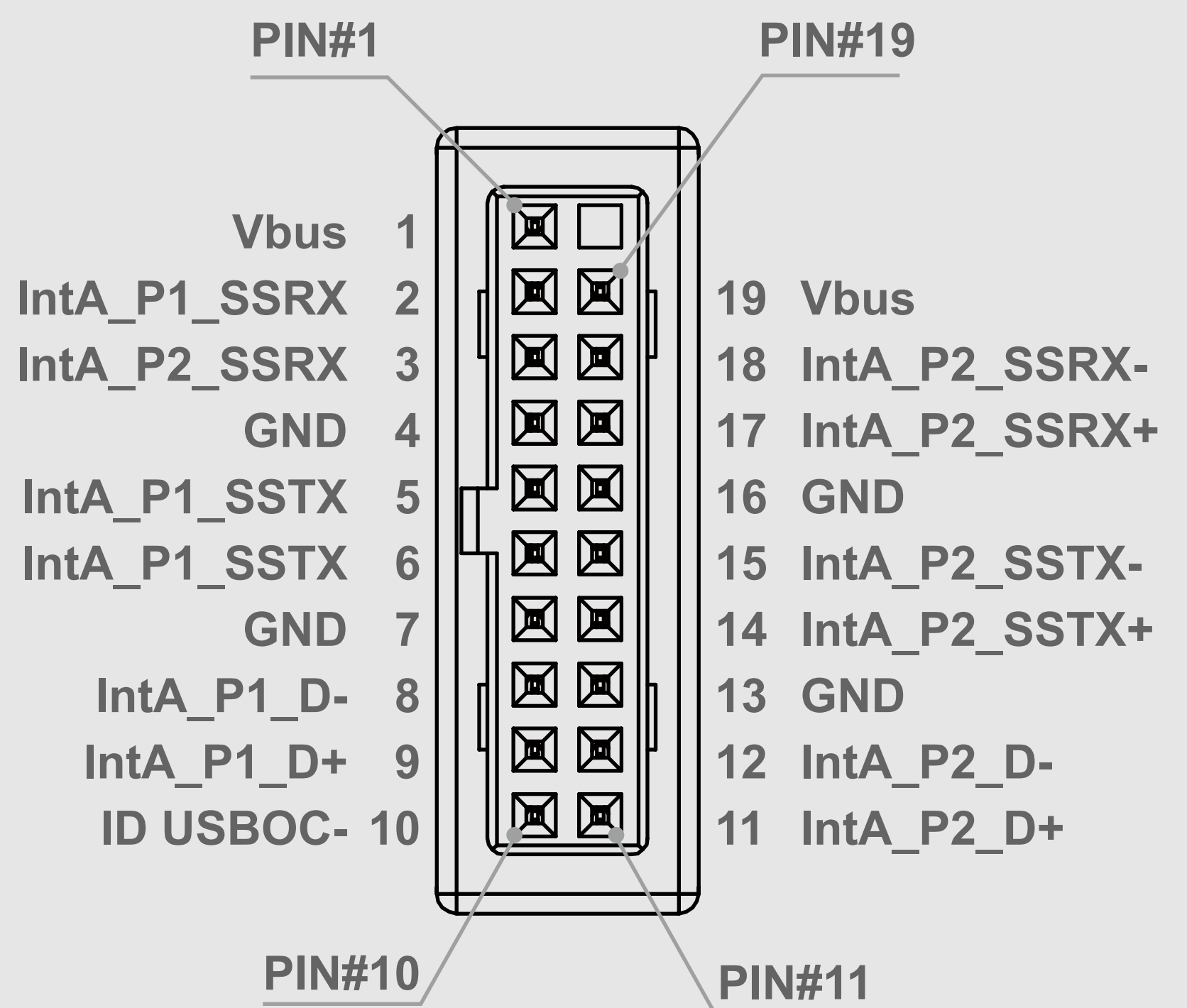
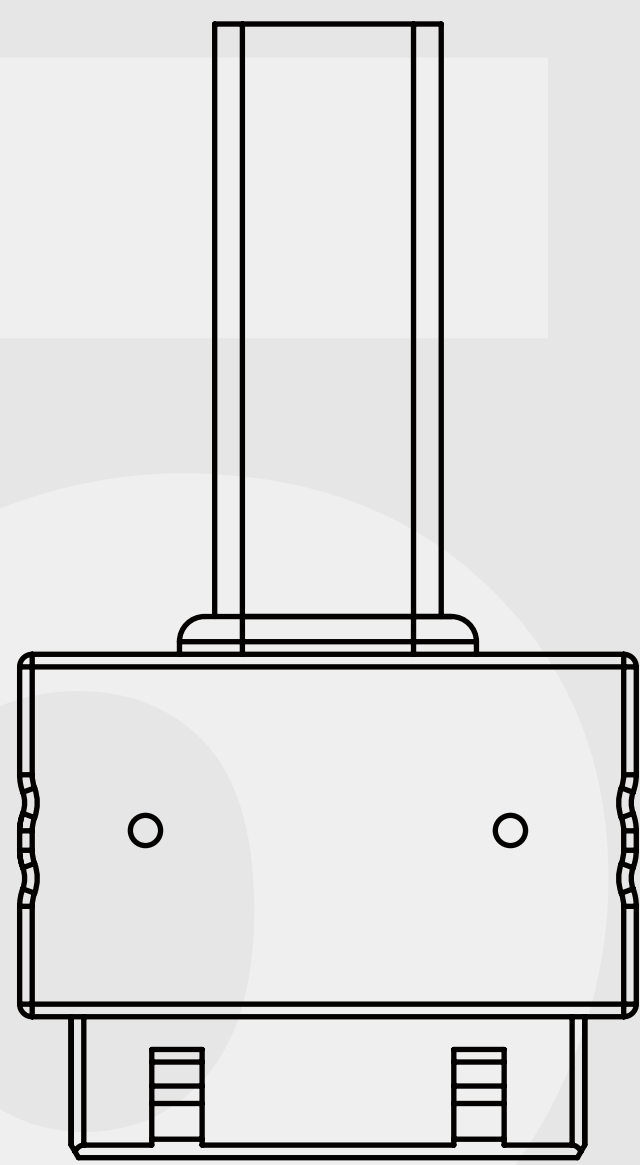

## The Instructions of RGB-Strip

If your motherboard support the RGB luminous effect, please follow the direction of sign and insert RGB-strip into the 4-pin RGB-strip header directly on the motherboard.

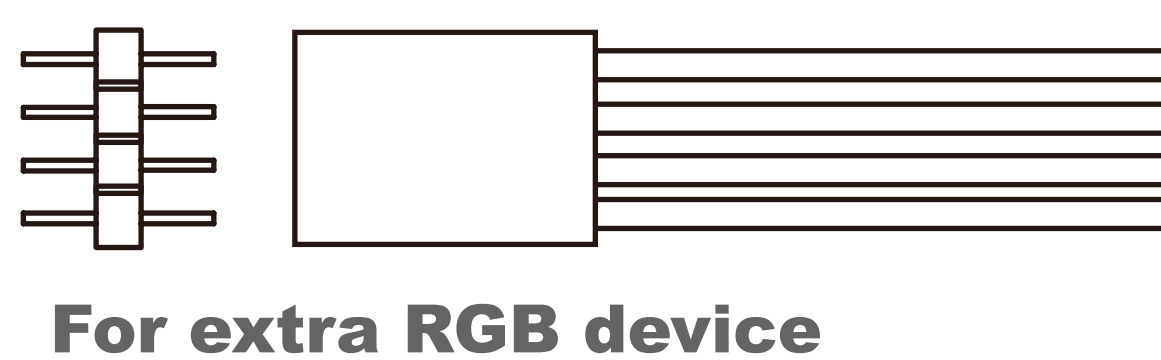
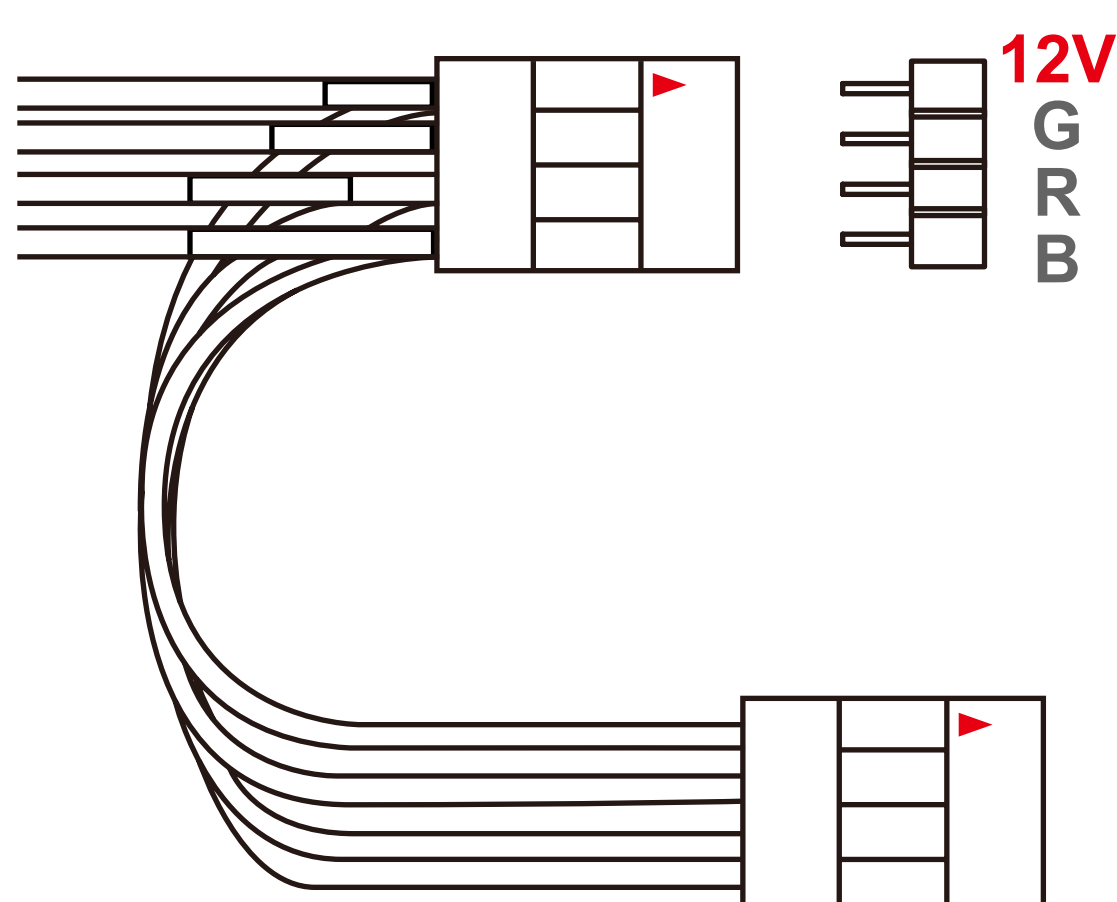
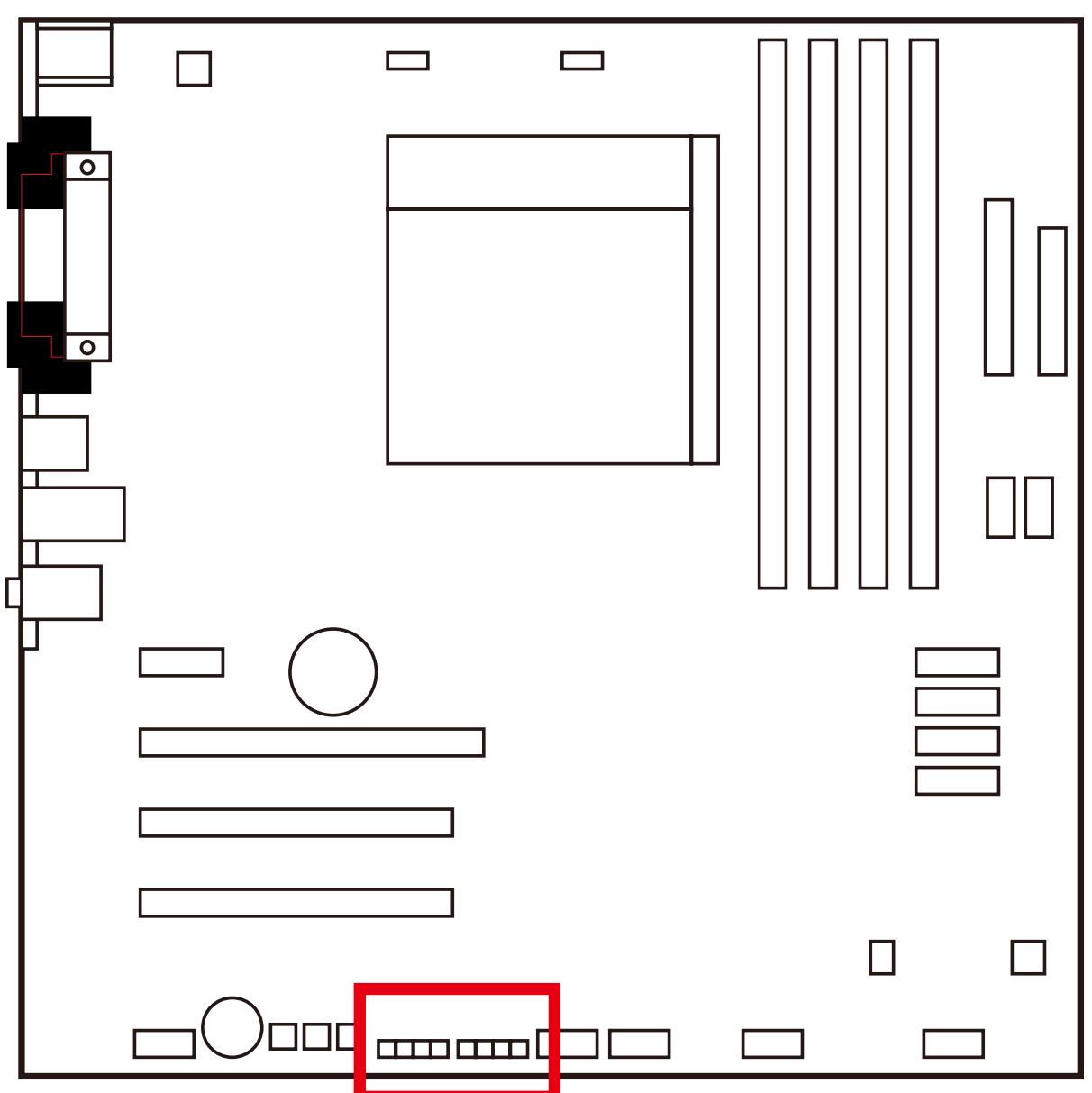
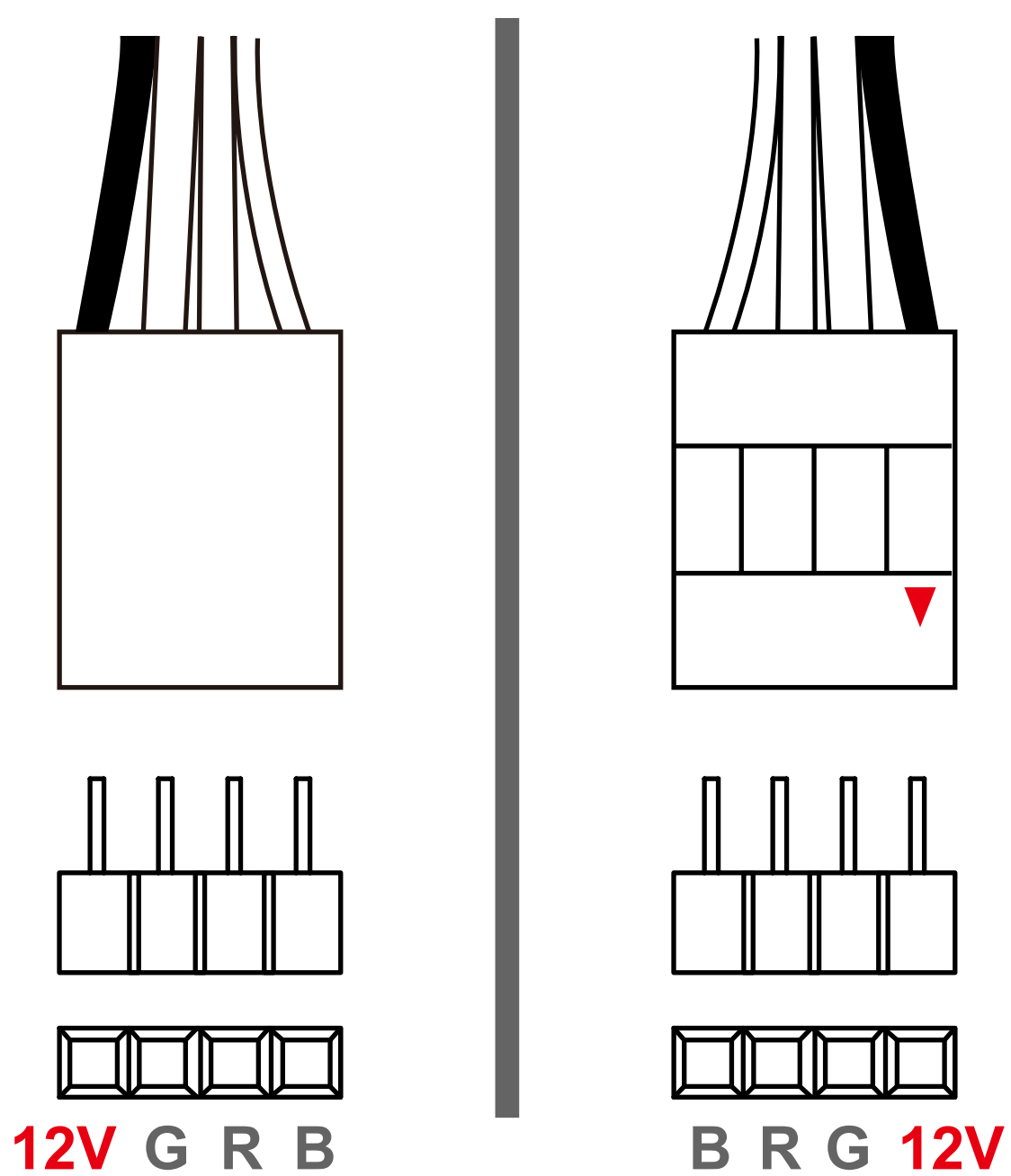
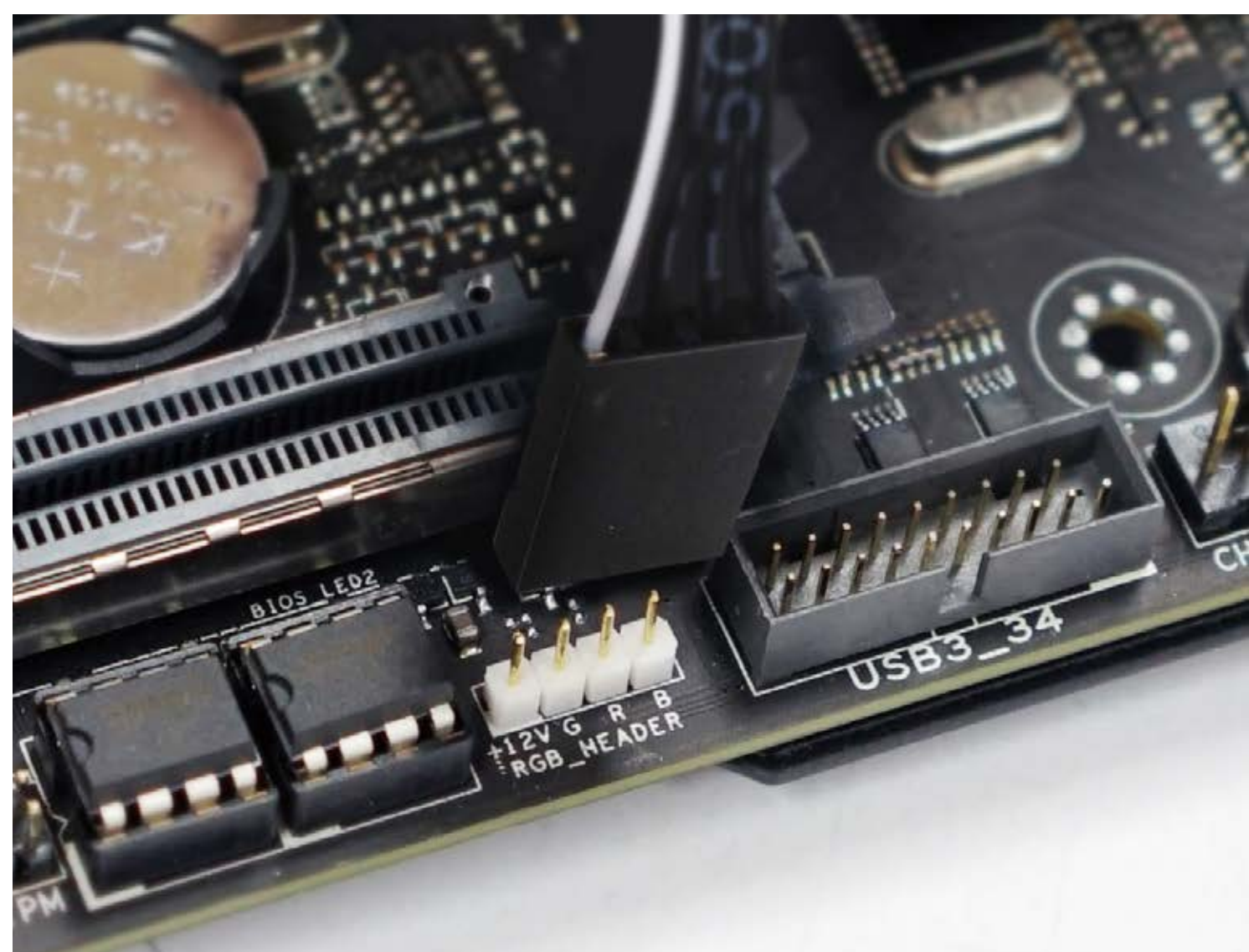

## The Instructions of Type-C Cable

If your motherboard supports Type-C, please connect the Type-C connector with the header directly on the motherboard.

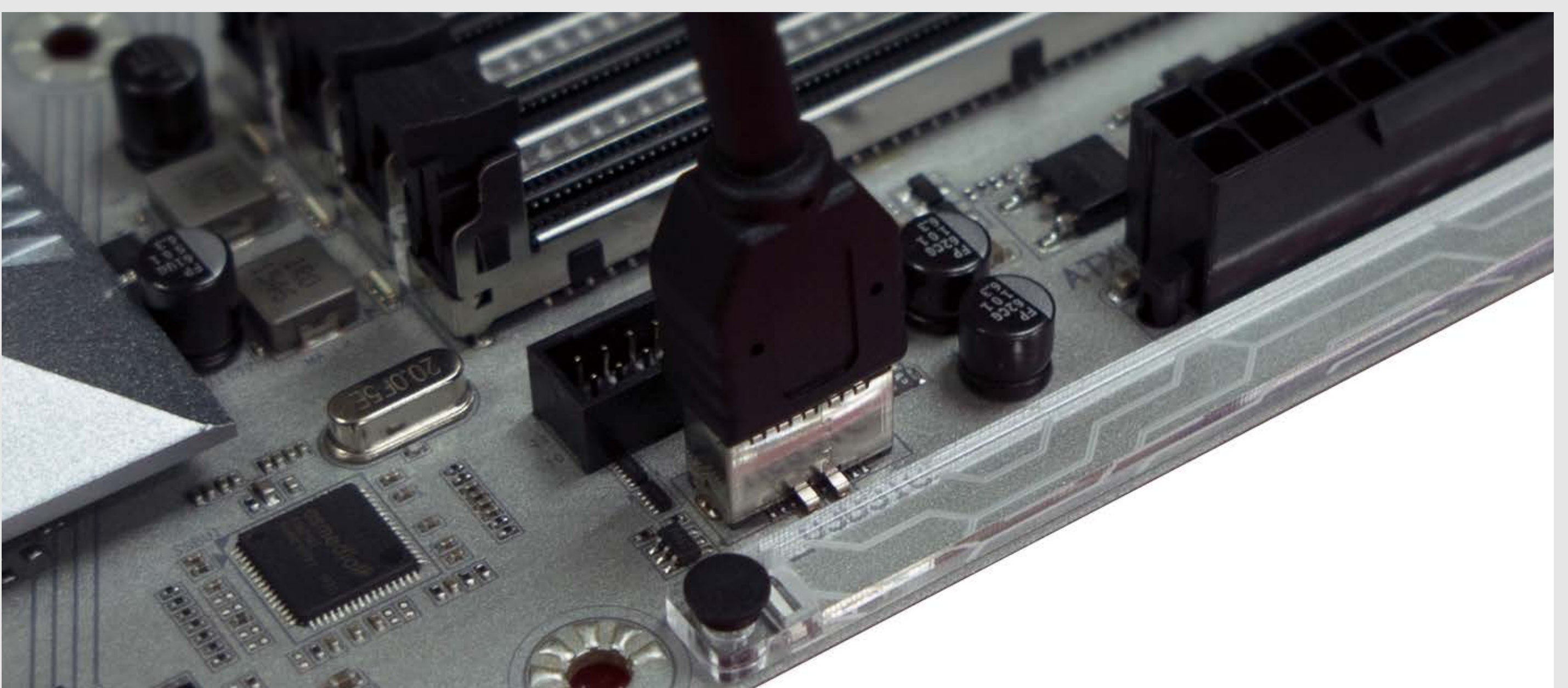
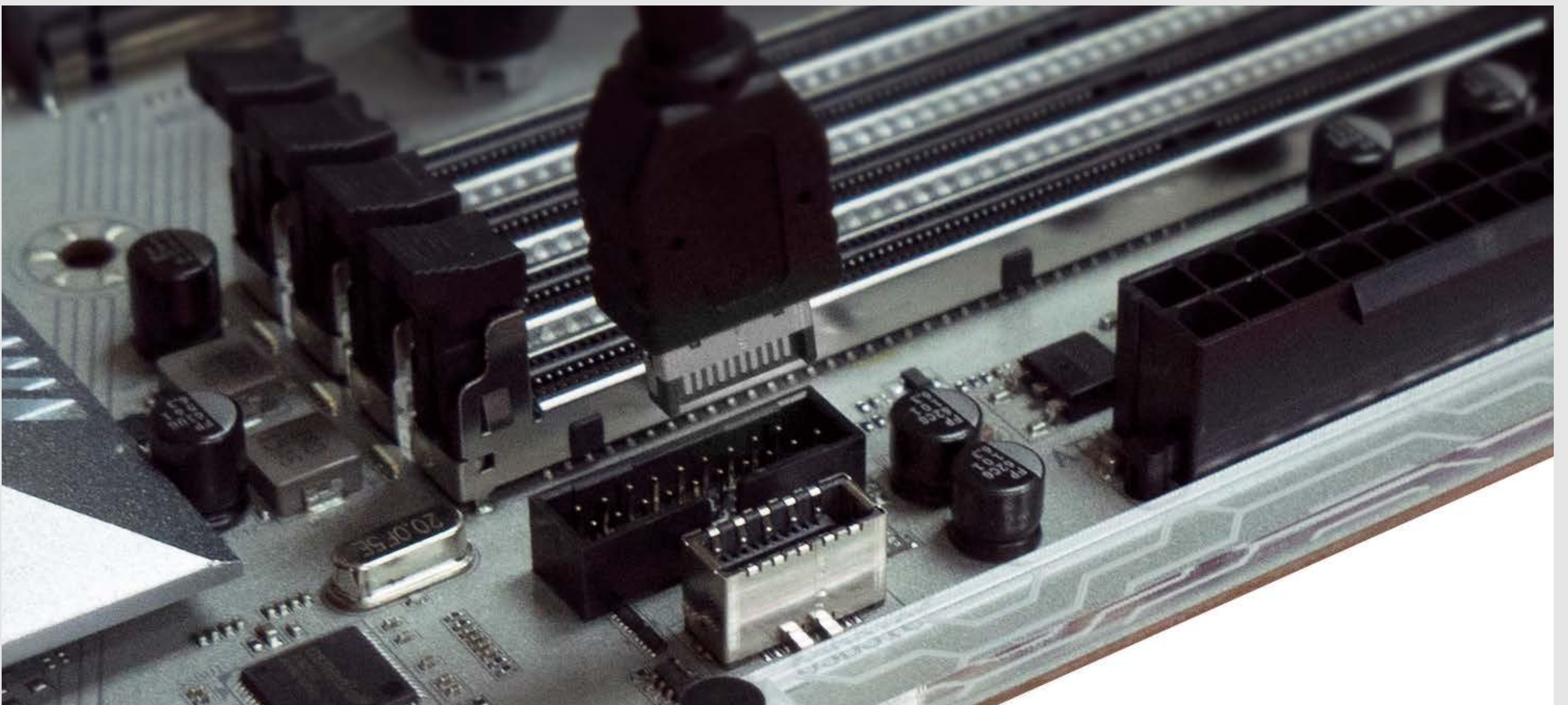
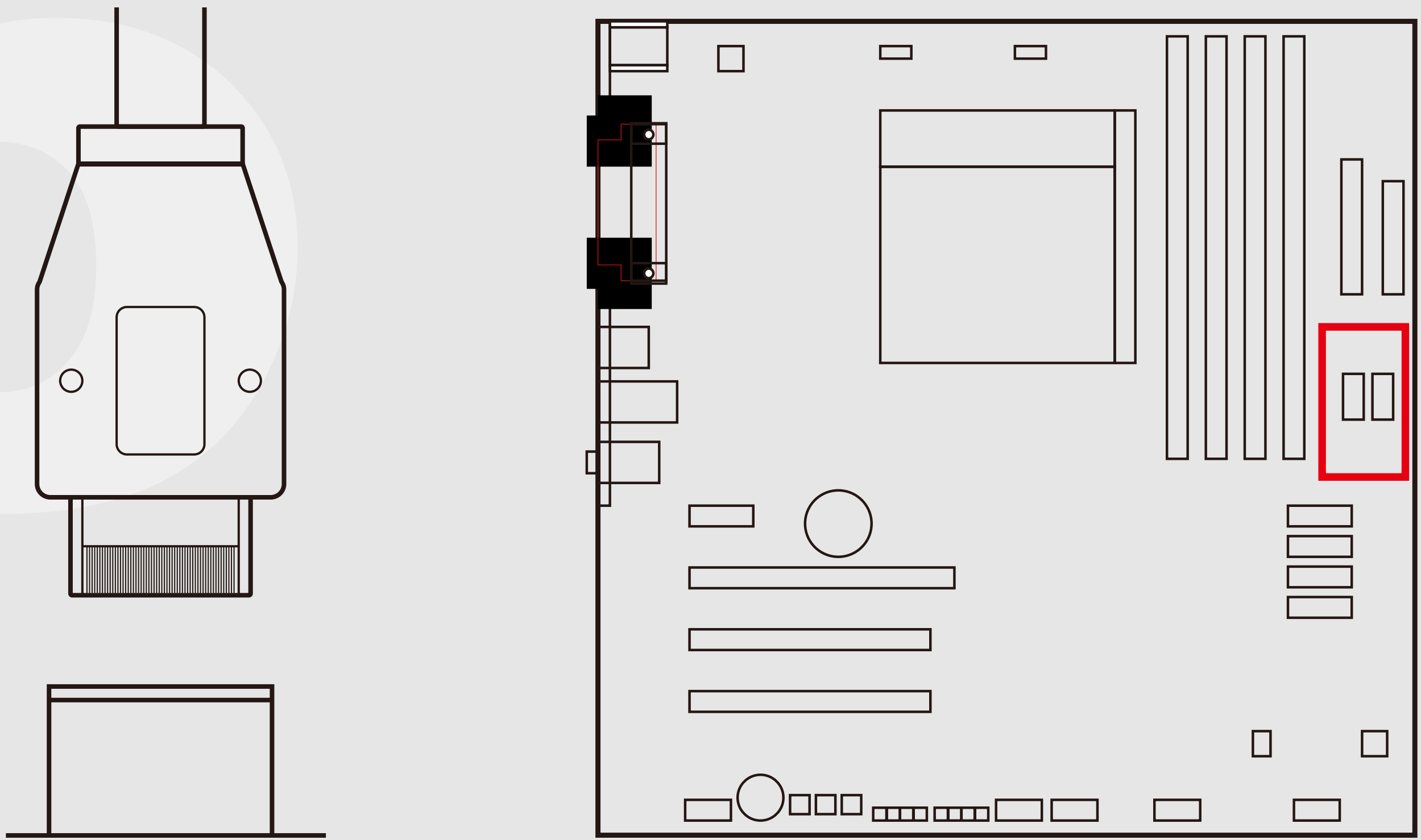

# 6

## 3.5"/ 2.5" Drive Bays Installation

---

Parts Required: 2.5" HDD Screws

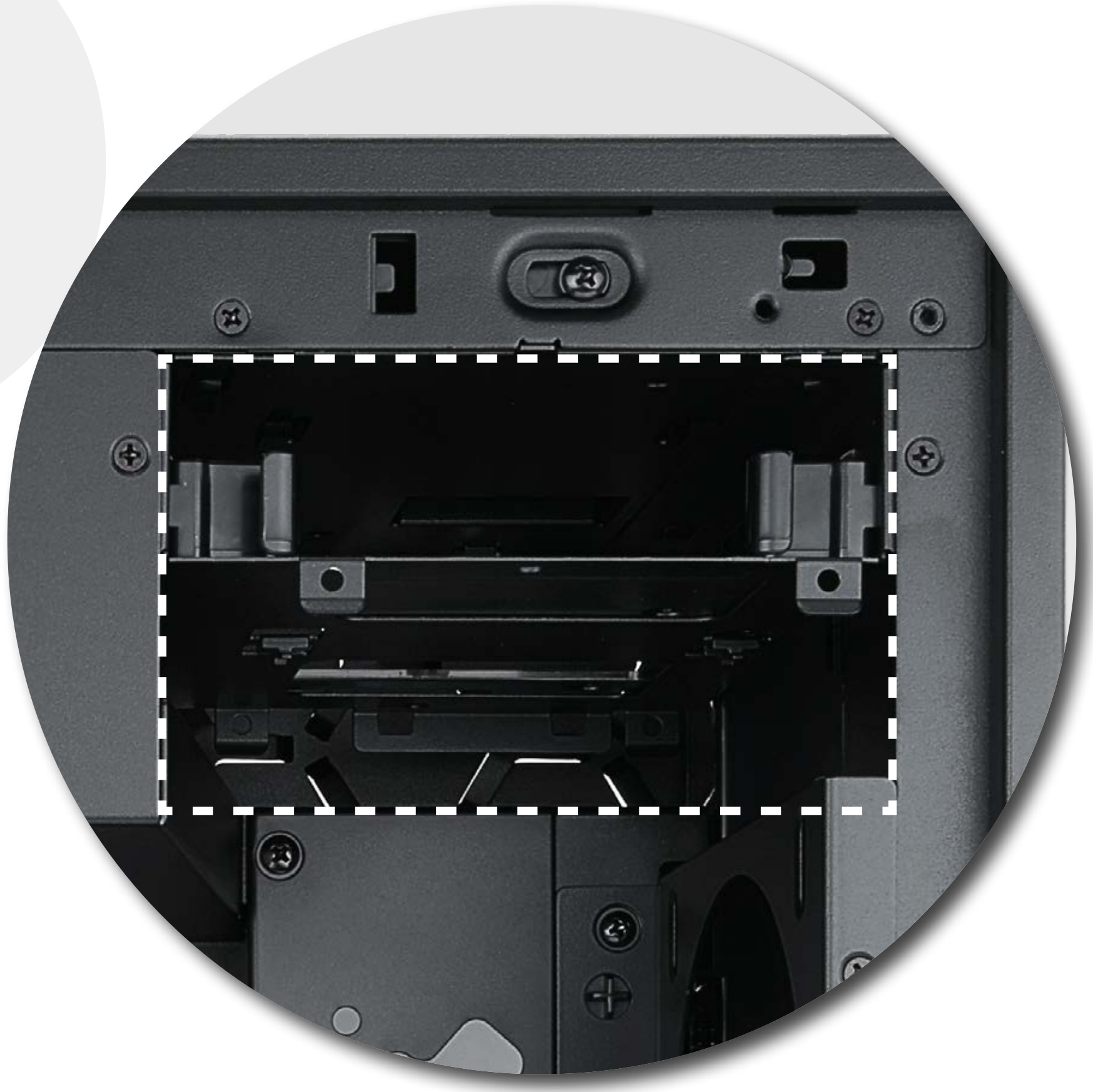

# 7

## Fan / Liquid Cooling Radiator Installation

---

Parts Required:  
Water-cooling System Washer



# 8

## Hiding Cable Lines

---

Parts Required: Cable Ties



# 9

## Completing Installation

---



# Notices and Warranty

## ■ Notices

1. Please follow the user manual for installation.
2. When installing the computer components, please use the antistatic precautions to prevent ESD (electrostatic discharge) damage. This can cause injury to the installer and/or damage to the machine. Incorrect installation may burn motherboard and other system components.
3. To avoid any damages, please do not use this product for any other purpose than its intended use.
4. Any modifications may damage the product.
5. Please remove all internal devices before shipping or moving. (Including power supply, hard drive, CD-ROM, motherboard and CPU, etc)

---

## ■ Warranty

- \* For more detailed warranty information, please visit In Win retail website at [www.in-win.com](http://www.in-win.com).
- \* The actual product is subject to change without prior notice. In Win Development Inc. reserves the right to make final modifications.



**IN WIN**

**CONTEMPORARY & INNOVATIVE**  
**w w w . i n - w i n . c o m**