



STRIX Sound Card Series

Strix Raid DLX

Strix Raid PRO

Strix Soar

User Manual

E11113
Revised Edition v2
November 2015

Copyright © 2015 ASUSTeK COMPUTER INC. All Rights Reserved.

No part of this manual, including the products and software described in it, may be reproduced, transmitted, transcribed, stored in a retrieval system, or translated into any language in any form or by any means, except documentation kept by the purchaser for backup purposes, without the express written permission of ASUSTeK COMPUTER INC. ("ASUS").

Product warranty or service will not be extended if: (1) the product is repaired, modified or altered, unless such repair, modification or alteration is authorized in writing by ASUS; or (2) the serial number of the product is defaced or missing.

ASUS PROVIDES THIS MANUAL "AS IS" WITHOUT WARRANTY OF ANY KIND, EITHER EXPRESS OR IMPLIED, INCLUDING BUT NOT LIMITED TO THE IMPLIED WARRANTIES OR CONDITIONS OF MERCHANTABILITY OR FITNESS FOR A PARTICULAR PURPOSE. IN NO EVENT SHALL ASUS, ITS DIRECTORS, OFFICERS, EMPLOYEES OR AGENTS BE LIABLE FOR ANY INDIRECT, SPECIAL, INCIDENTAL, OR CONSEQUENTIAL DAMAGES (INCLUDING DAMAGES FOR LOSS OF PROFITS, LOSS OF BUSINESS, LOSS OF USE OR DATA, INTERRUPTION OF BUSINESS AND THE LIKE), EVEN IF ASUS HAS BEEN ADVISED OF THE POSSIBILITY OF SUCH DAMAGES ARISING FROM ANY DEFECT OR ERROR IN THIS MANUAL OR PRODUCT.

SPECIFICATIONS AND INFORMATION CONTAINED IN THIS MANUAL ARE FURNISHED FOR INFORMATIONAL USE ONLY, AND ARE SUBJECT TO CHANGE AT ANY TIME WITHOUT NOTICE, AND SHOULD NOT BE CONSTRUED AS A COMMITMENT BY ASUS. ASUS ASSUMES NO RESPONSIBILITY OR LIABILITY FOR ANY ERRORS OR INACCURACIES THAT MAY APPEAR IN THIS MANUAL, INCLUDING THE PRODUCTS AND SOFTWARE DESCRIBED IN IT.

Products and corporate names appearing in this manual may or may not be registered trademarks or copyrights of their respective companies, and are used only for identification or explanation and to the owners' benefit, without intent to infringe.

Contents

1.	Introduction	4
1.1	Package contents	4
1.2	System requirements	4
1.3	General Specification	5
2.	Hardware overview	8
	Control Box	9
3.	Driver Installation	11
3.1	Installing the driver	11
3.2	Uninstalling or reinstalling the driver	12
4.	Connecting Speakers and Peripherals	13
4.1	Connecting to Strix Control Box (Strix Raid DLX/PRO only)	13
4.2	Connecting to TOSLINK and COAXIAL SPDIF input connection	15
4.3	Connecting Microphone/ Line In	16
4.4	Connecting stereo headphones	17
4.5	Connecting Analog Speaker Systems	18
5.	Software Utilities	22
5.1	Sonic Studio overview	22
5.2	Sonic Radar overview	23
6.	Troubleshooting	24
	Notice	27
	Trademarks	27
	License	27
	Copyright	27

1. Introduction

1.1 Package contents

Check your ASUS STRIX sound card series package for the following items:

- STRIX sound card series 7.1-Channel sound card
- Driver CD
- S/PDIF TOSLINK optical adapter x 1
- Quick Start Guide
- Box link cable (Strix Raid DLX/Strix Raid Pro only)
- Strix control box (Strix Raid DLX/Strix Raid Pro only)

1.2 System requirements

To ensure a successful installation of the ASUS Strix sound card series, your computer must meet the following requirements:

- One PCI Express 1.0 (or higher) compatible slot for the audio card
- One available 6-pin peripheral power cable connector from PC's power supply unit
- Microsoft® Windows® 10/8.1/8/7/(32/64bit)
- Intel® Pentium® 4 1.4GHz or AMD Athlon 1400 CPU or faster CPU
- >256 MB DRAM system memory
- >60 MB available HDD space for driver installation package
- CD-ROM drive (or DVD-ROM drive) for software installation
- High-quality headphones, powered analog speakers, or a Dolby Digital decoder, to enjoy the ultra-high fidelity sounds of the card

1.3 General Specification

STRIX RAID DLX

Items	Description
Audio Performance	
Output Signal-to-Noise Ratio (A-Weighted)	124dB for Front channel of Line-out 124dB for Headphone-out with 600ohm load
Input Signal-to-Noise Ratio (A-Weighted)	117dB
Output Total Harmonic Distortion + Noise at 1kHz (-3dB)	0.0009% (-107dB) for Line-out 0.0009% (-107dB) for Headphone-out with 600ohm load
Input Total Harmonic Distortion + Noise at 1kHz (-3dB)	0.000316% (-110dB) for Line-in
Frequency Response (-3dB, 24-bit/96kHz format)	< 10Hz to 48KHz
Output / Input Full-Scale Voltage	2 Vrms (5.65 Vp-p)
Bus Compatibility	
PCI Express	PCIe v1.0 or above bus compatible
Main Chipset	
Audio Processor	Cmedia USB 2.0 High-Definition Sound Processor (Max. 384KHz / 24bit)
D-A Converter of Digital Sources:	ESS SABRE9016 Premier 8 Channel Audio DAC
A-D Converter for Analog Inputs:	Cirrus-Logic CS5381* 1 (114dB DNR, Max. 192kHz/24bit)
Sample Rate and Resolution	
Analog Playback Sample Rate and Resolution	44.1K/48K/88.2K/96K/176.4K/192KHz @ 16/24bit
Analog Recording Sample Rate and Resolution	44.1K/48K/88.2K/96K/176.4K/192KHz @ 16/24bit
S/PDIF Digital Output	44.1K/48K/96K/192KHz @ 16/24bit
ASIO 2.0 Driver Support	44.1K/48K/96K/192KHz @ 16/24bit

* Individual spec for each card.

(Continued on next page)

Items	Description
I/O Ports	
Analog Output Jack	3.5mm jack (1/8") (Analog out for all channel) 3.5mm jack (1/8") (Headphone out)
Analog Input Jack	3.5mm jack (1/8") (Line-In/Mic-In combo)
Digital S/PDIF Output	High-bandwidth Optical connector supports 192KHz/24bit (Side Surround combo)
Driver Features	
Operation System	Windows 8.1/8/7 (32/64 bit)

STRIX RAID PRO/SOAR

Items	Description
Audio Performance	
Output Signal-to-Noise Ratio (A-Weighted):	116dB for Line out (Front) 110dB for Headphone-out@600ohm loading
Input Signal-to-Noise Ratio (A-Weighted):	110dB for line-in
Output Total Harmonic Distortion + Noise at 1kHz (A-Weighted) :	0.001% (-100dB) for Line out 0.003% (-90dB) for headphone-out@600ohm loading
Input Total Harmonic Distortion + Noise at 1kHz (A-Weighted) :	0.000316% (-110dB) for line-in
Frequency Response (-3dB, 24-bit/96kHz input):	<10Hz to 48kHz
Output/Input Full-Scale Voltage	2Vrms (5.65Vp-p)
Headphone Impedance	Optimized for 16, 32-600Ω
Bus Compatibility	
PCI	PCIe v1.0 or above bus compatible
Main Chipset	
Audio Processor	Cmedia USB 2.0 High-Definition Sound Processor (Max. 384KHz/24bit)
D-A Converter of Digital Sources:	ESS SABRE9006A Premier 8 Channel Audio DAC
A-D Converter for Analog Inputs:	Cirrus Logic CS5361*1 (114dB DNR, Max. 192KHz/24bit)

(Continued on next page)

Items	Description
Sample Rate and Resolution	
Analog Playback Sample Rate and Resolution	44.1K/48K/88.2/96/176.4/192KHz @ 16/24bit for all channels
Analog Recording Sample Rate and Resolution	44.1K/48K/88.2/96/176.4/192KHz @ 16/24bit for all channels
S/PDIF Digital Output	44.1K/48K/96/192KHz @ 16/24bit
ASIO 2.0 Driver Support:	44.1K/48K/96/192KHz @ 16/24bit
I/O Ports	
Analog Output Jack:	3.5 mm jack (1/8") Analog out for All channel
	3.5 mm jack (1/8") Headphone out
Analog Input Jack:	3.5 mm jack (1/8") (Line-In/Mic-In combo)
Digital S/PDIF Output	High-bandwidth Optical Connector supports 192KHz/24bit (Side Surround combo)
Driver Features	
Operation System	Windows 8.1/8/7(32/64bit)

2. Hardware overview

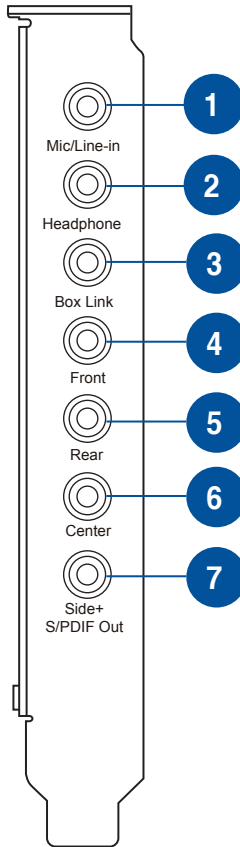

No.	Items	Description
1	Microphone In port	Connect your external PC microphone to this 3.5mm port for voice input. Built-in high-quality Microphone pre-amplifier.
	Line In port	Connect analog devices like MP3 players, CD players, music synthesizers, and other line-level sound sources to this 3.5mm port for audio recording or processing.
2.	Headphone Out port	Connect your headphone to this port.

No.	Items	Description
3.	Box link	Connect Strix control box directly to this port.
4.	Front Out port	For 2-channel speaker systems, connects to the input on the powered speakers.
5.	Rear Out port	Connects to the rear surround input on 4.1-channel powered analog speakers.
6.	Center Out port	Connects to the center/subwoofer input on 4.1/5.1-channel powered analog speakers.
7.	Side Out port	Connects to the side surround input on 7.1-channel powered analog speakers.
	S/PDIF Out port	Optical digital output jack. Connects to external digital decoder or digital speaker systems, Home Theater systems, AV receivers for outputting digital audio including PCM, Dolby Digital, DTS, WMA-Pro, etc. Connects to the surround channel input on 4.1/5.1/7.1-channel powered analog speakers.

Control Box

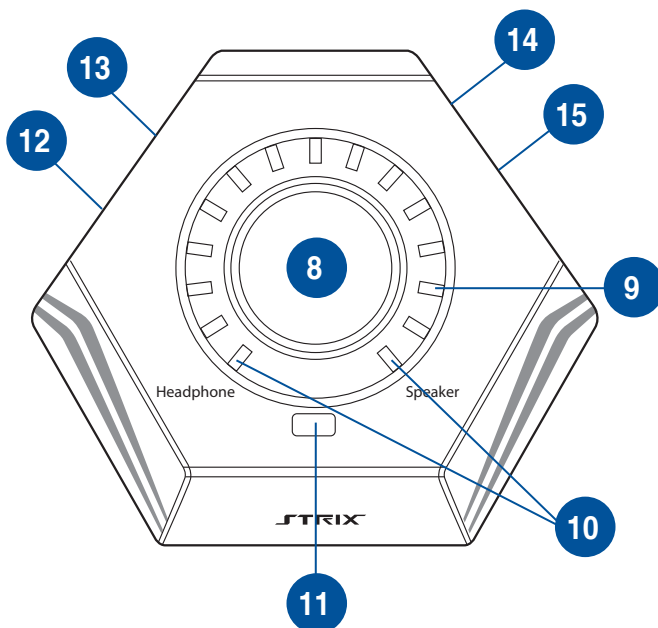

No.	Items	Description	
8.	Output Select / Volume Control	Tab	Tab to select output source between the headphone and speaker.
		Long Press	Long press to set the selected output source to mute.
		Turn	Turn the knob clockwise or anti-clockwise to adjust volume level.
		[Custom Mode]: Tab	<p>CUSTOM MODE (In conjunction with STRIX RAID MODE)</p> <p>Tab the knob to turn on/off a selected effect.</p> <p>Note: This control knob is used in conjunction with the Strix RAID key. When Strix RAID Mode is selected, this goes into a custom mode.</p>
		[Custom Mode]: Turn	<p>CUSTOM MODE (In conjunction with STRIX RAID MODE)</p> <p>Turn the knob clockwise or anti-clockwise to adjust intensity level of a selected effect.</p>
9.	LED Indicators	LED indicator that displays intensity level of volume or effects.	
10.	Output Source LED Indicator	<p>LED indicator that displays selected output device.</p> <p>Note: When the device is mute, the LED turns red.</p>	
11.	STRIX RAID Mode	<p>This is a programmable key that can customize and lock a special effect from the Sonic Studio so that you can control and adjust effects spontaneously in game.</p> <p>Press on/off to enable/disable Custom Mode. The LED turns orange to indicate that the Custom Mode is enabled.</p> <p>To set up this key, please go to the Sonic Studio and select an effect to lock the Strix RAID Mode.</p> <p>Now you can use the knob to enable/disable an effect, as well as adjust the intensity level of the effect.</p>	
12.	Headphone Output Port	Connect your headphone to this port.	
13.	Microphone Input Port	Connect your external PC microphone to this 3.5mm jack for voice input.	
14.	Kensington® Security Slot	Insert kensington lock to lock the device.	
15.	Box link	Connect Strix control box directly to this port.	

3. Driver Installation

3.1 Installing the driver

After installing the STRIX sound card series on your computer, you need to install the device driver that enables the STRIX sound card series to work with Windows® operating system.



-
- The driver is only needed when you connect ASUS STRIX sound card series with PC/NB.
 - The version and contents of the support CD are subject to change without notice.
-

To install the device driver:

1. Insert the ASUS STRIX sound card series support CD into your optical drive. If Autorun is enabled, the ASUS STRIX sound card series driver screen appears automatically. Go to step 4. If Autorun is not enabled in your computer, perform step 2.
2. Click **My Computer** on your desktop and double-click the optical drive icon.
3. Double-click the **setup.exe** icon.
4. Follow the on-screen instructions to complete the installation. Read the **END USER LICENSE AGREEMENT** in the process and make sure that you understand and accept it before continuing the installation.
5. When the installation finishes, you may be prompted to restart your computer. You can choose to restart the computer later if desired.

3.2 Uninstalling or reinstalling the driver

3.2.1 Uninstalling the STRIX sound card series driver

To uninstall the STRIX sound card series driver:

1. Click **Start > Settings > Control Panel**.
2. Double click the **Add/Remove Programs** icon.
3. Click the **Change or Remove Programs** button.
4. Select the program that you want to remove and then click **Add/Remove** (or **Change/Remove**) button.
5. In the **InstallShield Wizard** dialog box, select **Remove**.
6. Restart your computer when prompted.

3.2.2 Reinstalling the STRIX sound card series driver

To reinstall the STRIX sound card series driver:

1. Before you reinstall any software, it's recommended to uninstall the existing software first.
2. After you finish the uninstallation of the software, please follow the installation process again to reinstall the same or updated software.

4. Connecting Speakers and Peripherals

4.1 Connecting to Strix Control Box (Strix Raid DLX/PRO only)

4.1.1 Connecting Strix Control Box (Strix Raid DLX/PRO only)

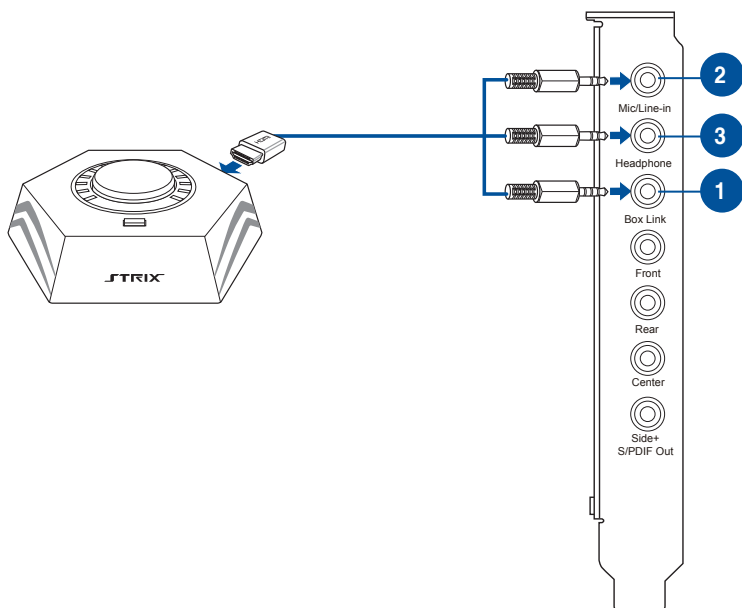

No.	Items	Description
1.	Box link	Connect Strix control box directly to this Box link port .
2.	Microphone Input Port	Connect Strix control box directly to the microphone input port .
3.	Headphone Output Port	Connect Strix control box directly to the headphone output port.

4.1.2 Connecting Strix Control Box with external microphone and headphone(Strix Raid DLX/PRO only)

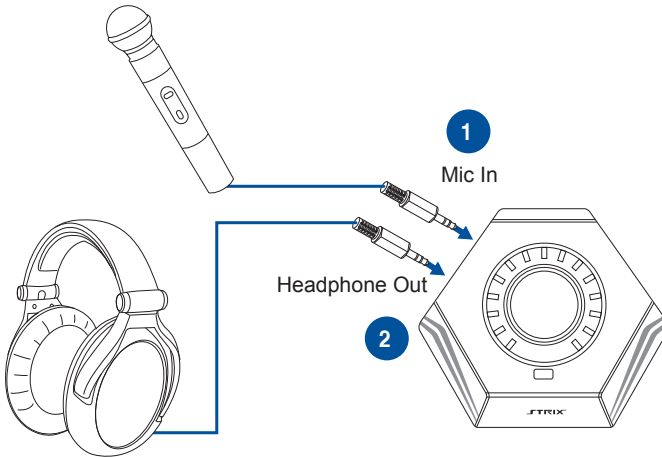

No.	Items	Description
1.	Microphone Input Port	Connect your external PC microphone to this 3.5mm jack for voice input.
2.	Headphone Output Port	Connect your headphones to this port.

4.2 Connecting to TOSLINK and COAXIAL SPDIF input connection

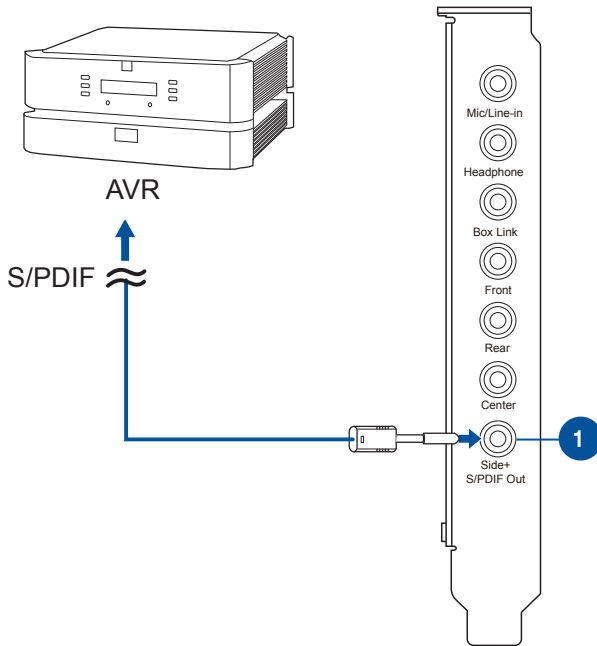

No.	Items	Description
1.	S/PDIF Output/Side Out port	Connects to CD/DVD player or some PC/NB with SPDIF output to digital input.

4.3 Connecting Microphone/ Line In

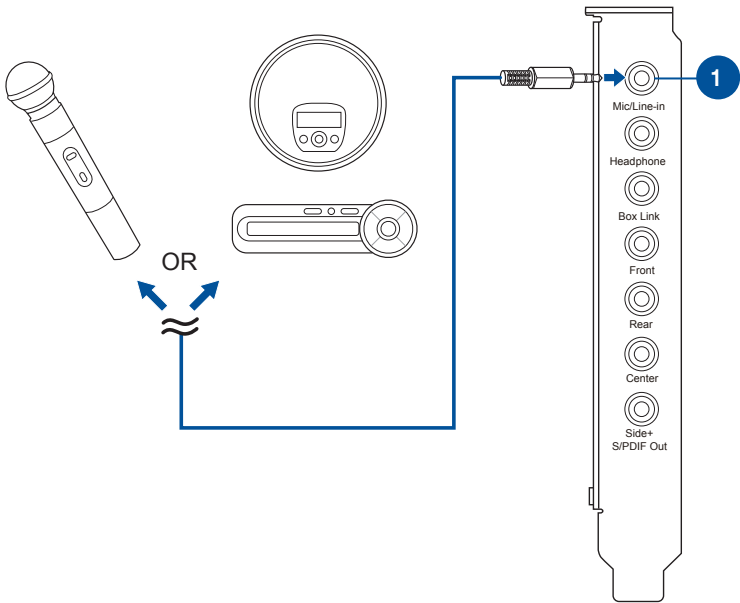

No.	Items	Description
1.	Microphone Input/ Line In Port	<p>Connect the microphone's 3.5mm plug into this Mic-In port for voice communication, recording, or karaoke.</p> <p>Connect the 3.5mm plug of the CD/MP3 Player or any other Line level analog audio sources into this Line-In jack for sound recording.</p>

4.4 Connecting stereo headphones

4.4.1 Connecting Stereo Headphones

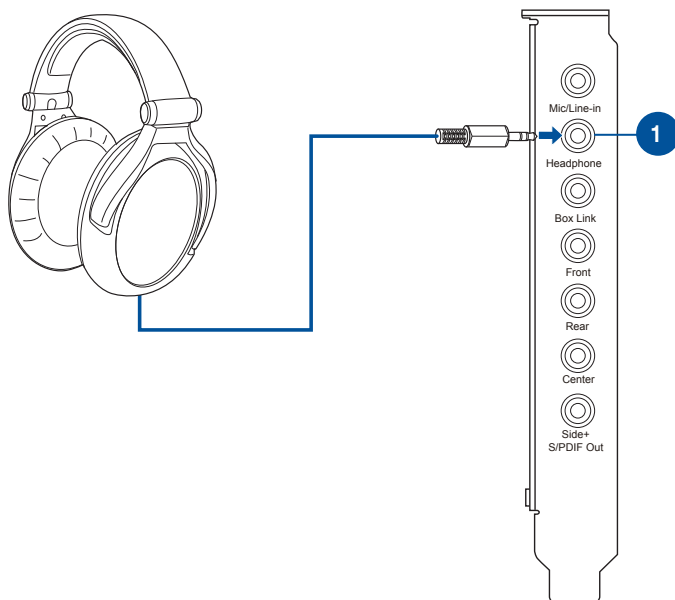

No.	Items	Description
1.	Front Out	The Headphone Out Port has a built-in high-quality amplifier to drive headphones. Please connect your stereo headphones directly to this jack.

4.5 Connecting Analog Speaker Systems

4.5.1 Connecting 2 channel speakers

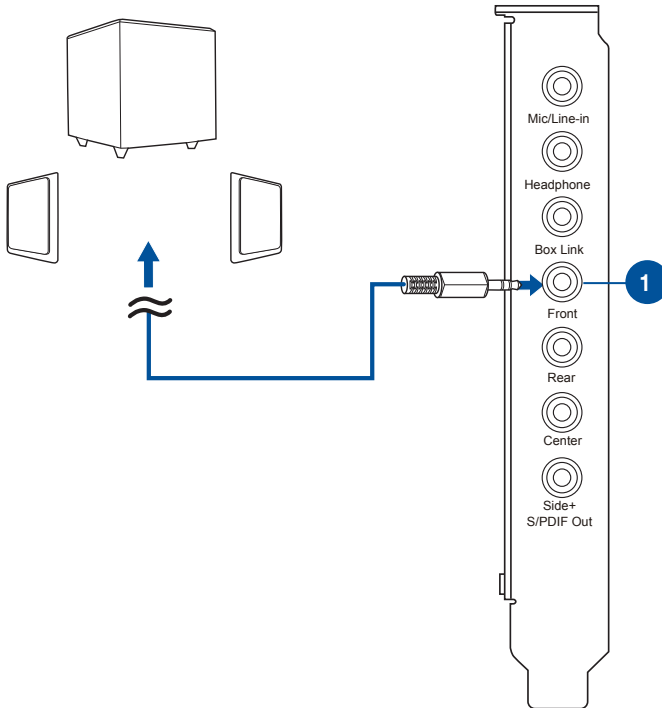

No.	Items	Description
1.	Front Out	Connects to the front input ports of the 2 channel speakers with the mini-jack cable.

4.5.2 Connecting 4 Channel Speakers / Power Amplifier

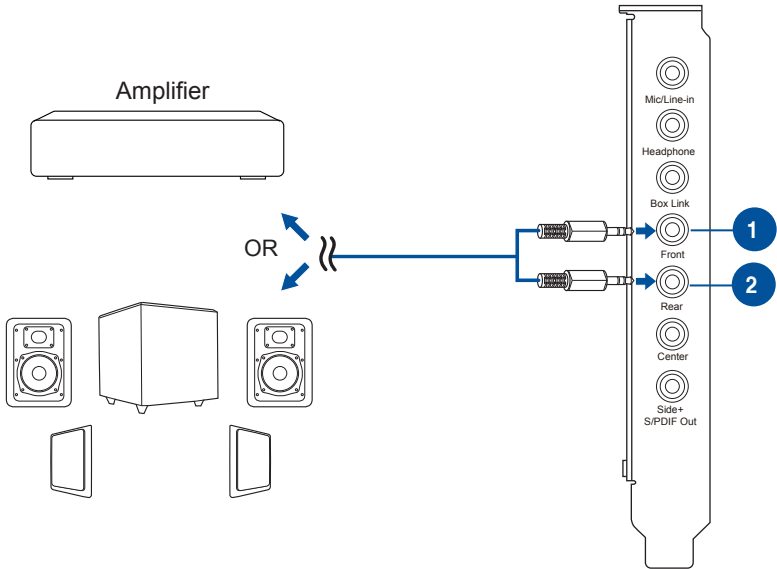

No.	Items	Description
1.	Front Out	Connects to the front input ports of 4.1 speaker.
2.	Rear Output Port	Connects to the rear surround input port of 4.1 channel speaker.

4.5.3 Connecting 5.1 Channel Speakers / 5.1 Channel Headphone

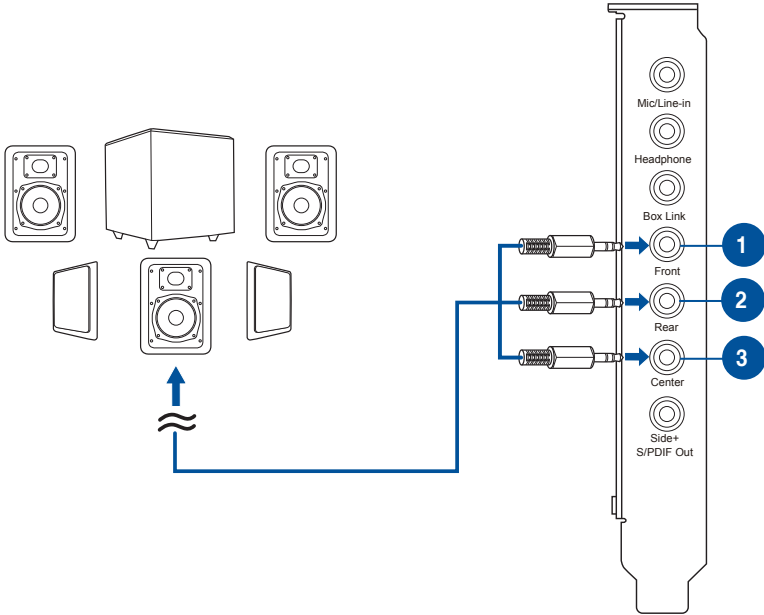

No.	Items	Description
1.	Front Out	Connects to the front input ports of 5.1 speaker.
2.	Rear Output Port	Connects to the "left surround" and "right surround" input ports of 5.1 speaker.
3.	Center/Subwoofer	Connects to the "Center" and "subwoofer" input ports of 5.1 speaker.

4.5.4 Connecting 7.1 Channel Speakers

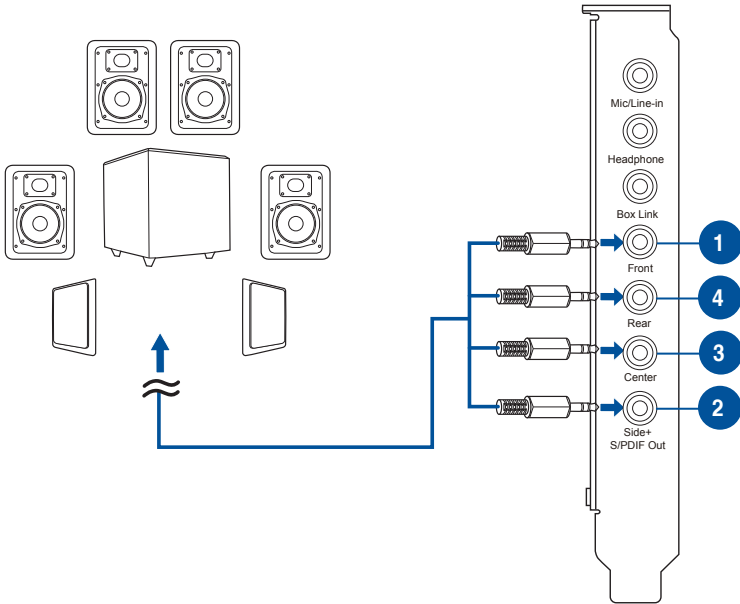

No.	Items	Description
1.	Front Out	Connects to the front input ports of 5.1 speaker
2.	Side Surround Out	Connects to the "left surround" and "right surround" input ports of 7.1 speaker
3.	Center/Subwoofer	Connects to the Center/Subwoofer input port of the 7.1 speakers with the mini-jack cable.
4.	Rear Output Port	Connects to the rear surround input of 7.1 speaker

5. Software Utilities

5.1 Sonic Studio overview

Sonic Studio comes with advanced sound algorithms and virtual surround effects to enhance your gaming and entertainment experience.



For more details about using Sonic Studio please refer to the Sonic Studio and Sonic Radar manual.

5.2 Sonic Radar overview

Sonic Radar is a visualization overlay of audio elements that can be easily selected, combined and re-focused for gaming. This helps gamers to visually see threats which are heard but are not immediately visible. Gamers can also customize the appropriate level of sensitivity and graphics settings to meet his/her needs for different gaming scenarios.



For more details about using Sonic Radar please refer to the Sonic Studio and Sonic Radar manual.

6. Troubleshooting

1. I cannot install the audio card driver in my PC.

- Please make sure that you have properly plugged the audio card in the PCI Express slot on your motherboard.
- Check that the Windows hardware device manager has discovered a multimedia audio device. If no device is found, please try scanning for new hardware.
- Please try soft reboot (restart) your Windows.
- Remove the card, plug it into another PCI Express slot, and try again.

2. I couldn't find the STRIX Sound Card Series Audio Center.

- Please make sure you have installed the driver
- Find the STRIX Sound Card Series Audio Center icon in the system tray on the bottom right-hand corner of the screen. Double click the icon to open the STRIX Sound Card Series Audio Center utility.
- If the icon could not be found in the system tray, go to the Windows Control Panel and double click the "STRIX Sound Card Series Audio Center" icon to make it visible in the system tray again.
- After the driver installation is complete, it's recommended that you reboot your computer to complete the setup. If the icon still doesn't appear, please try installing the driver package again.

3. I can't hear any sound from my analog speakers.

- STRIX sound card series PCI Express audio card needs the power cable to supply addition power in addition to the basic PCI Express bus power. Please double check you have plugged the small 4-pin power plug onto STRIX sound card series power connector. If you did not plug the internal power, STRIX Sound Card Series Audio Center will remind you a warning message and won't allow your operation when you double click STRIX Sound Card Series Audio Center icon in the system tray.
- Please ensure that you have connected speakers properly and have powered on your speakers
- Please ensure that the device master volume or the software player has NOT been muted on the STRIX Sound Card Series Audio Center
- If you are using Dolby Digital Live encoder through the S/PDIF output, the analog output will be muted to get rid of the interference between your digital speaker system and analog speakers or headphones. Please check if this is the case.
- Please go to the sound and audio device of Windows Control Panel to check if the playback default device is set to STRIX Sound Card Series Audio Device, instead of other onboard AC97 or HDA codec device. If it's not, please set it to STRIX Sound Card Series Audio Device and restart your applications.
- Please try restart your Windows.

4. I can't hear any sound from the S/PDIF output.

- Please ensure that you have enabled S/PDIF output in the Audio Center GUI (Main page)
- Please ensure that you are connecting the correct S/PDIF output jack on the card to the decoder's (AV receiver) S/PDIF input jack
- You may need to select the correct input and mode of your decoder or AV receiver. For Dolby Digital or DTS output, you may have to double check that the AV receiver is in that decoding mode.
- If you are using 192KHz PCM output, please make sure your decoder can support 192KHz decoding. Try changing it to 44.1K or 48KHz first.

5. I can't hear audio input (Mic, Line-in, AUX, etc.) from my speakers.

- Please select the correct input as the recording source. If you are using Windows Vista/Win 7, please also go to system audio control panel to see the current default recording/input device is right.
- Please remember to turn on the digital monitoring button for that recording source

6. Will PCM sound output through S/PDIF be just 2 channels even with different analog output channels?

The S/PDIF protocol specification (IEC-60958) can only carry 2-channel PCM data or non-PCM AC3/DTS data. So, when a user selects PCM output for S/PDIF, the sound card will always deliver 2 channel PCM data through the S/PDIF output port. For attaining 5.1 channel surround sounds, you can select DDO, which will allow the STRIX sound card series to deliver 5.1 surround sound for DVD movies, and even stereo music.

Notice

The content furnished in this document is ASUS audio product knowledge for customers' reference. However, ASUS assumes no responsibility for the consequences of use of such information. The information included is subject to change without notice. This publication supersedes and replaces all information supplied previously. No part of this manual can be reproduced or transmitted in any form or by any means for any purpose without the permission of .ASUSTek Computer Inc.

Trademarks

and ASUS logo are trademarks of ASUSTek Computer Inc. "Dolby" and "Dolby Digital Live", "Dolby Pro Logic IIx", "Dolby Virtual Speaker", "Dolby Headphone" are trademarks of Dolby Laboratories. "DTS" and "DTS CONNECT", "DTS Interactive", "DTS Neo: PC" are trademarks of Digital Theater Systems, Inc. EAX and A3D are trademarks of Creative Technology Ltd. Microsoft, DirectSound3D, Windows are trademarks of Microsoft Corporation. Other company and product names may be trademarks of the respective companies with which they are associated. ASIO is a trademark and software of Steinberg Media Technologies GmbH

License

Dolby Master Studio driver is manufactured under license from Dolby Laboratories; DTS Connect driver is manufactured under license from Digital Theater Systems, Inc.

Copyright

Copyright © ASUSTek Computer Inc.

AEEE Yönetmeliğine Uygundur



CAN ICE-3 (B)/NMB-3 (B)

ASUS
Inspiring Innovation • Persistent Perfection

ASUS WARRANTY UPDATE

From 1 January 2012 updated warranties apply to all ASUS products, consistent with the Australian Consumer Law.

For the latest product warranty details please visit: <http://support.asus.com>

Our goods come with guarantees that cannot be excluded under the Australian Consumer Law. You are entitled to a replacement or refund for a major failure and compensation for any other reasonably foreseeable loss or damage. You are also entitled to have the goods repaired or replaced if the goods fail to be of acceptable quality and the failure does not amount to a major failure.

If you require assistance please call ASUS Customer Service 1300 2787 88 | <http://support.asus.com>