

SAMSUNG

REPAIR GUIDE

SM-X920
SM-X926B

English. 04/2025. Rev.2.1

www.samsung.com

Table of Contents

Usage Notices

- 5 Precautions for Repair
- 6 ESD (Electrostatic Discharge) Precautions
- 7 Instructional Icons

Software Update

- 8 Updating Software through FOTA
- 8 Software Update Failure
- 8 Updating Software through Smart Switch
- 9 Recovering from a Software Update Failure
- 9 Recovering on Another Computer
- 10 Performing a Factory Data Reset

Quality Test

- 12 Quality Test Using the Samsung Members App
- 12 Device Diagnostics
- 13 Test Items

Calibrations

- 26 Calibrations
- 26 Used Parts and Calibration Functions in Supported Models
- 27 Using the Self Repair Assistant App
- 32 Optical Fingerprint Sensor Calibration
- 35 Resetting the Battery Cycle Count
- 38 Range Sensor Calibration
- 40 Touch Screen Panel Calibration
- 42 Speaker Calibration

- 44 Under-display Camera Calibration (Fold Models Only)
- 46 Digital Hall Sensor Calibration (Fold and Flip Models Only)

Exploded View and Parts List

- 49 Exploded View
- 50 Parts List

Disassembly and Assembly

- 52 Tools for Disassembly and Assembly
- 57 Fasteners (Adhesives and Materials) for Assembly
- 62 Disassembly and Reassembly for replacement
 - 63 SIM Card Tray
 - 63 Disassembly
 - 65 Reassembly
 - 66 Screen
 - 66 Disassembly
 - 78 Reassembly
 - 102 Bracket
 - 102 Disassembly
 - 104 Reassembly
 - 106 Microphone
 - 106 Disassembly
 - 108 Reassembly
 - 112 Charging Port
 - 112 Disassembly
 - 121 Reassembly
 - 131 Rear Camera
 - 131 Disassembly
 - 134 Reassembly

137	Front Camera
137	Disassembly
139	Reassembly
141	Speaker1
141	Disassembly
152	Reassembly
165	Speaker 2
165	Disassembly
174	Reassembly
183	Speaker 3
183	Disassembly
195	Reassembly
210	Speaker 4
210	Disassembly
219	Reassembly
231	Battery
231	Disassembly
236	Reassembly
251	Button
251	Disassembly
253	Reassembly
255	Back Cover
255	Disassembly
281	Reassembly
320	Directive 2012/19/EU Annex VII Components

Usage Notices

All functionality, features, specifications, and other device information provided in this document, including but not limited to, benefits, design, pricing, components, performance, availability, and capabilities of the device are subject to change without notice. Samsung reserves the right to alter this document or the device described herein at any time, without obligation to provide notification of such changes.

Precautions for Repair

Samsung is not liable for any damage or defect determined to be caused by repair by a non-authorized carrier, self repair or non-professional repair of the device. Samsung is not liable for any resulting damage to the device, or any injury or other device safety issue caused by any attempt to repair the device which does not follow these repair and maintenance instructions.

Any damage to the device or defect caused by an attempt to repair the device by any person other than a Samsung certified carrier will not be covered by the warranty.

- Use only demagnetised tools that are specifically designed for small electronic repairs, as most electronic parts are sensitive to electromagnetic forces.
- Use only high quality screwdrivers when servicing devices. Low quality screwdrivers can easily damage the heads of screws.
- Always use genuine replacement parts. Third-party replacement parts may not function properly and could cause a fire or injury.
- Some parts, such as sensors (laser AF/proximity/fingerprint), the rear camera, the TSP (touch panel), speakers, and other components, may need calibration to guarantee their performance after repair.
- The performance of the device's water and dust resistance cannot be guaranteed when it is repaired by the user or another unskilled worker.
- If you need to access the failure data of your device or need to get a more detailed diagnosis, visit a Samsung Service Centre.
- If you need to replace unsold parts, visit a Samsung Service Centre and receive further instruction.
- Before conducting repairs, remember to make backup copies of all important data stored in the device.



- Make sure to wear the appropriate safety equipment before carrying out repairs. Samsung is not responsible for injuries that may occur because of not wearing the proper safety equipment. Refer to [Tools for Disassembly and Assembly](#) for a list of tools that you will need for assembling and disassembling the device.
- Repair the device in a safe place.
- Before repairing the device, make sure the device is turned off. To turn off the device, press the Volume Down button and the Side button at the same time, or open the notification panel and tap the Power icon.
- If the device is damaged, emits smoke, or if you smell something burning, stop using the device immediately and contact Samsung.
- It is recommended to use safety equipment such as glasses, gloves, and a mask when repairing the device.
- Be careful not to damage the device when removing the back cover.
- Before assembly, ensure that there are no screws or foreign objects around the battery.
- During assembly, check if there are any abnormalities before reattaching the back cover, and be careful not to damage the battery by hitting or denting it. If the battery is damaged, visit a Samsung Service Centre.
- Do not place the device directly into a microwave and heat it.
- Before repairing your device, make sure its battery is fully discharged.
- Visit www.samsung.com to view the device information, related material, and safety information.

ESD (Electrostatic Discharge) Precautions

It is the sudden flow of electricity between two electrically charged objects caused by contact, an electrical short, or dielectric breakdown. ESD can cause negative effects on mobile devices, especially electrical parts.

- It is recommended to use ESD safety (Anti-static) equipment such as an anti-static wrist strap and gloves, and an ESD safe mat when repairing the device.
- Increase the airflow to the work area to decrease the chance of accidental static electricity discharges, as the potential for static electricity discharge may be increased in low-humidity environments, such as air-conditioned rooms.

Instructional Icons

-  **Warning:** situations that could cause injury to yourself or others
-  **Caution:** situations that could cause damage to your device or other equipment
-  **Notice:** notes, usage tips, or additional information

Software Update

Updating Software through FOTA

Update your device's software through the firmware over-the-air (FOTA) service. You can also schedule software updates.

Launch the **Settings** app and tap **Software update** → **Download and install**.

- **Install now:** Install updates.
 - **Schedule install:** Set the time to install updates automatically.
-  • You may incur additional charges when updating the software through a mobile network.
- If the latest software has been downloaded to the device, these options will not appear.

Software Update Failure

If your device becomes disconnected from a network before the update is complete, the update may fail. Reconnect to a network and complete the update.

Updating Software through Smart Switch

You can use Smart Switch to update your device's software to the latest version. You must download the desktop version of the Smart Switch app from www.samsung.com/smartswitch.



-  • This feature may not be supported on some devices or computers.
- Limitations apply. Visit www.samsung.com/smartswitch for details. Samsung takes copyright seriously.

- 1 On the computer, visit www.samsung.com/smartswitch to download Smart Switch.
- 2 On the computer, launch **Smart Switch**.
- 3 Connect your device to the computer using the device's USB cable.
- 4 Click **Update**.

- 5 Read the on-screen instructions and click **Continue**.
- 6 Read the precautions about the update and click **OK**.
- 7 Read and agree to the terms and conditions.
The update will start.



Recovering from a Software Update Failure

If a software update is interrupted because of an error on your device or computer, your device may fail to operate normally. If this occurs, you can perform a factory data reset on your device for emergency recovery.

-  Before performing the factory data reset, remember to make backup copies of all important data stored in the device. Samsung is not responsible for the loss of data stored in the device.
- 1 Disconnect your device from the computer and launch **Smart Switch** again on the computer.
 - 2 Click  → **Emergency Software Recovery and Reset**.
The device list will appear.
 - 3 Click the device that experienced a software update error and click **Device reset** → **OK**.
The device will perform a factory data reset.

Recovering on Another Computer

If the emergency recovery process continues to fail on the computer where the software update failed, you can repair your device on another computer using the recovery code. This will include a factory data reset of your device.

- 
 - Before performing the factory data reset, remember to make backup copies of all important data stored in the device. Samsung is not responsible for the loss of data stored in the device.
 - The recovery code can be found only on the computer where the software update has failed.
- 1 On the computer where the software update has failed, launch **Smart Switch**.
 - 2 Click  → **Emergency Software Recovery and Reset**.

- 3 On the devices list, click the device that failed to update the software and check the recovery code.
- 4 On another computer, launch **Smart Switch**.
- 5 Click **⋮** → **Emergency Software Recovery and Reset** → **Emergency code recovery**.
- 6 Enter the recovery code and click **OK**.
- 7 Follow the on-screen instructions to put your device into recovery mode and complete the emergency recovery.

Performing a Factory Data Reset

The factory data reset restores the device's default settings. This erases all data, including files and downloaded apps, from the device.

-  Before performing the factory data reset, remember to make backup copies of all important data stored in the device. Samsung is not responsible for the loss of data stored in the device.

Make sure your device's battery level is sufficient, as losing power during a factory reset may result in system problems.

- 1 Launch the **Settings** app and tap **General management** → **Reset** → **Factory data reset**.
- 2 Read the on-screen instructions and check which account you are signed in with. If your device is signed in to your Google account, log out of your Google account. If you do not log out of your Google account, logging in to another account after the factory data reset will not be possible, because your device will be locked.

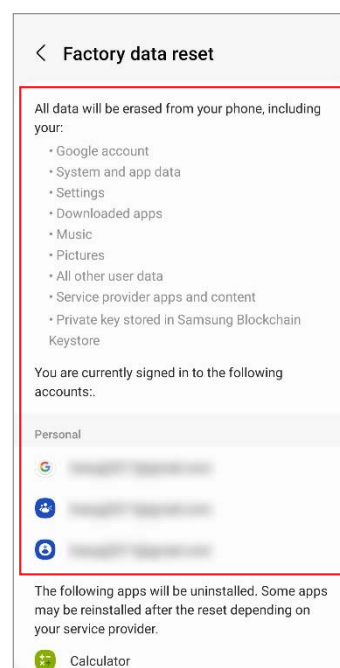

3 Tap **Reset** → **Delete all**.

All data will be deleted when rebooting.

-  During a factory data reset, the device may repeat rebooting and the logo may be displayed for a long time.

Quality Test

Quality Test Using the Samsung Members App

It is recommended to evaluate your device through the Samsung Members app after it has been repaired to guarantee its performance. If the test results show any abnormalities or that another malfunction has occurred because of the repair, visit a Samsung Service Centre to receive further instruction. Any malfunctions caused by your repair may incur additional repair charges.

-  • The Samsung Members app is subject to update without any prior notice.
- To use this feature, you must sign in to your Samsung account.
- Some features may not be available depending on the carrier or model.

Device Diagnostics

- 1 Launch the **Samsung Members** app.

If you do not have the app, download it from the **Galaxy Store** or **Play Store**.

- 2 Tap **Support** → **Phone diagnostics**.

The diagnostics screen will appear and you can check the test status and items.

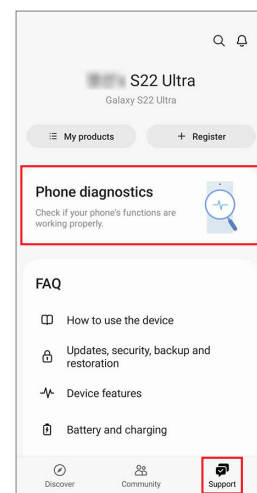

3 Tap **Test all**.

The device performs a test on all items.

When the test is finished, you can check the test results.

- Tick mark: Working normally
- Exclamation mark: Needs further inspection
- The test proceeds automatically, but you may need to follow the on-screen instructions depending on the test item. Keep an eye on the screen during testing to ensure smooth progress.
- If the exclamation mark appears on any test items after finishing the test, tap them to find the solutions. If the problem persists, visit a Samsung Service Centre.

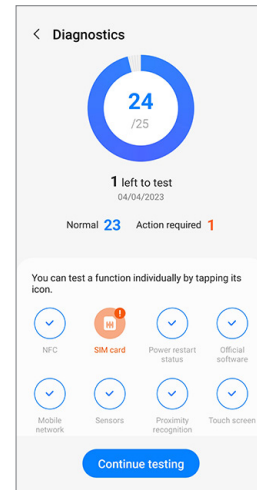

Test Items

NFC

- Function: Check whether your device can read near field communication (NFC) tags that contain information about products.
- Provided information
 - Status: View whether the feature is working normally.

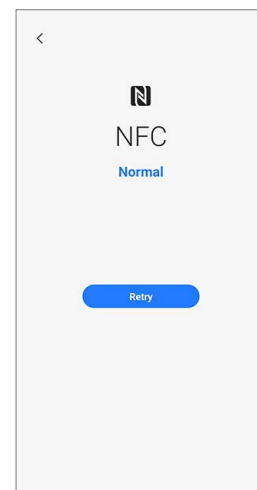

SIM card

- Function: Check whether the SIM card is working normally.
- Provided information
 - Status: View whether the feature is working normally.
 - Service provider: View the carrier.
 - Number: View the phone number.



If the test result is not **Normal**, remove the SIM card from the SIM card tray and replace it. If possible, try again with another SIM card.

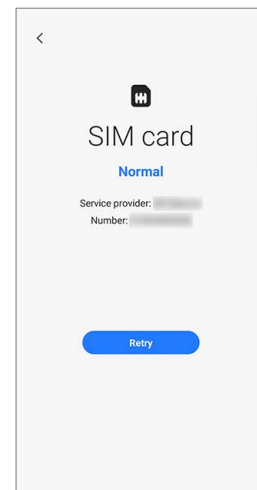

Power restart status

- Function: Check your device's restart history.
- Provided information
 - Status: View whether the feature is working normally.
 - FAQ: View frequently asked questions.
 - History: View your device's restart history.

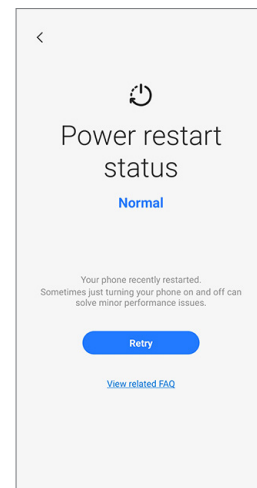

Official software

- Function: Check whether the software is working normally.
- Provided information
 - Status: View whether the feature is working normally.
 - Service information: View the Samsung Service Centre location.

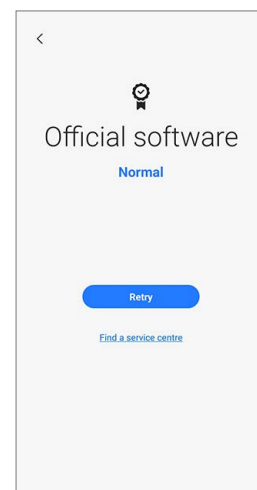

Mobile network

- Function: Check whether your mobile network is working normally.
- Provided information
 - Status: View whether the feature is working normally.
 - Settings: Configure your mobile network settings.
 - FAQ: View frequently asked questions.

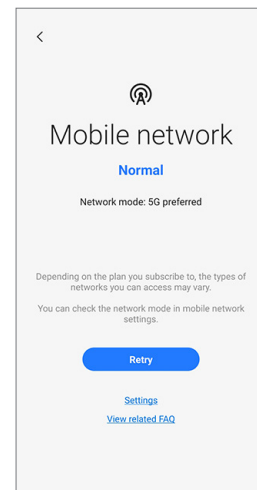

Sensors

- Function: Check whether the sensors are working normally.
- Provided information
 - Status: View whether the feature is working normally.
 - Sensor types: View the status of each sensor.

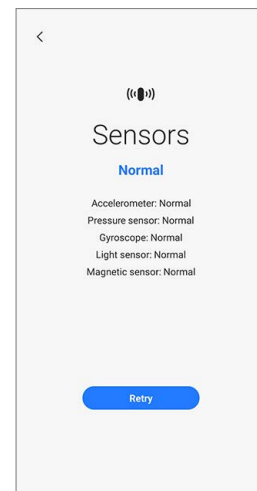

Proximity recognition

- Function: Check whether the proximity recognition feature is working normally.
- Provided information
 - Status: View whether the feature is working normally.
 - FAQ: View frequently asked questions.

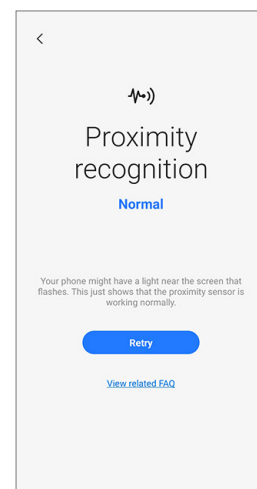

Touch screen

- Function: Check whether the touchscreen is working normally.
- Provided information
 - Status: View whether the feature is working normally.

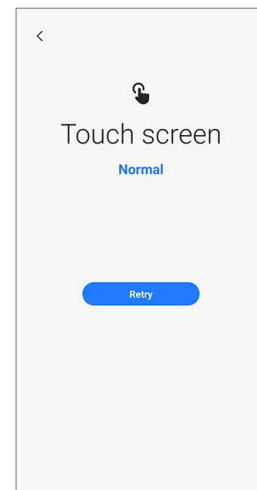

Buttons

- Function: Check whether the buttons are working normally.
- How to check:
Press the buttons by following the directions on the screen.
- Provided information
 - Status: View whether the feature is working normally.
 - Button types: View the status of each button.

 Make sure that the buttons are not contaminated to get more accurate test results.

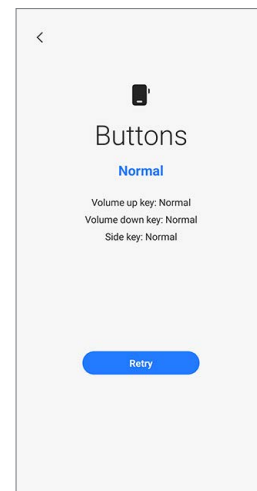

Torch

- Function: Check whether the torch is working normally.
- Provided information
 - Status: View whether the feature is working normally.

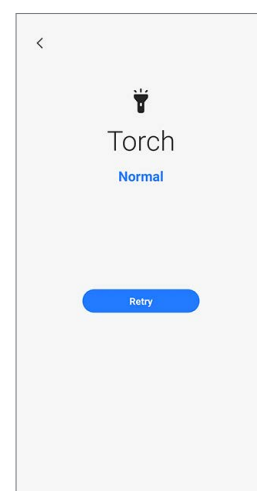

Speaker

- Function: Check whether the speakers are working normally.
- Provided information
 - Status: View whether the feature is working normally.
 - Speaker types: View the status of each speaker.
 - FAQ: View frequently asked questions.

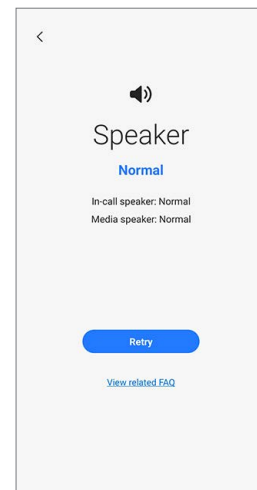

Vibration

- Function: Check whether the vibration feature is working normally.
- Provided information
 - Status: View whether the feature is working normally.
 - Vibration types: View the status of each type of vibration.
 - FAQ: View frequently asked questions.
 - History: View the vibration history.

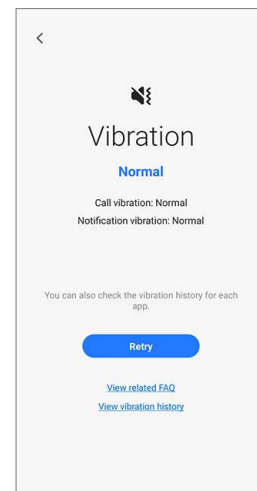

Camera

- Function: Check whether the rear and front cameras are working normally.
 - How to check:
Tap the camera button to test the rear and front cameras.
The picture that was taken will be displayed to check the quality of the pictures.
 - Provided information
 - Status: View the status whether the feature is working normally.
 - Camera types: View the status of each camera.
 - FAQ: View frequently asked questions.
-  To test this more accurately, check if the camera is obstructed by foreign objects, the case, or protective film.

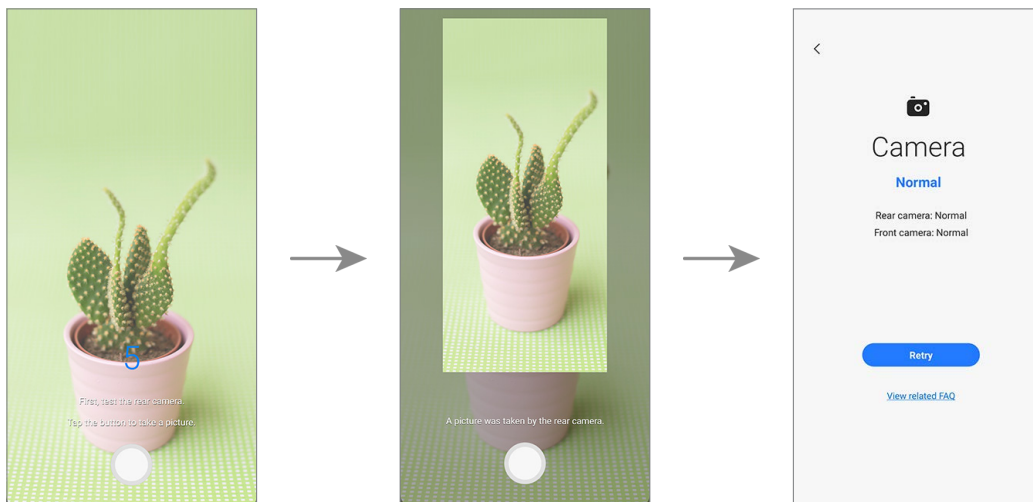

Mic

- Function: Check whether the microphone is working normally.
 - How to check:
 - 1) Tap **Record** and say something for the recording.
 - 2) When the recording is finished, tap **Play** and select a button according to the question.
 - Provided information
 - Status: View whether the feature is working properly.
 - Mic types: View the status of each mic.
 - FAQ: View frequently asked questions.
-  • The number of tests may vary depending on the model.
- If you cannot hear anything after recording, check whether the media volume is turned up.

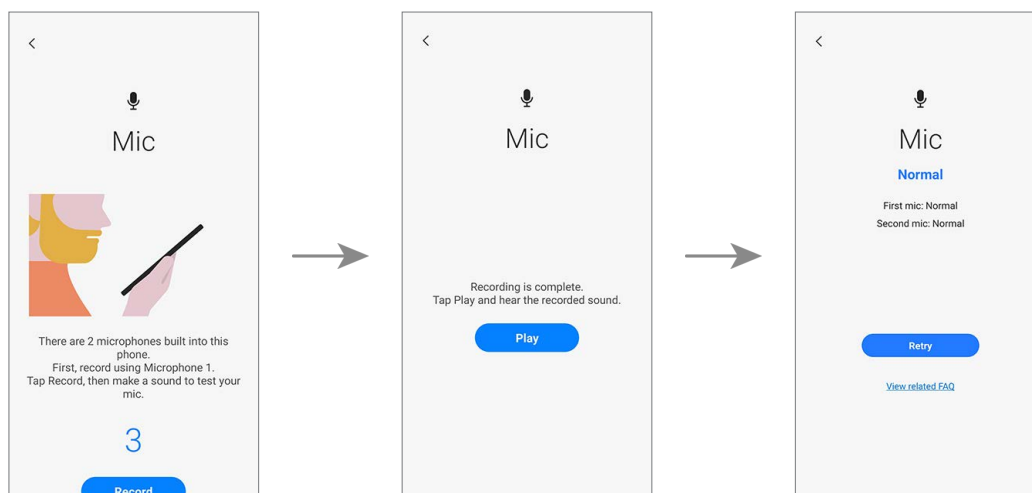

Location accuracy

- Function: Check whether the location accuracy is working normally.
- How to check:
Tap **Start**.
- Provided information
 - Status: View whether the feature is working normally.
 - FAQ: View frequently asked questions.



The results might be more accurate when you test outside.

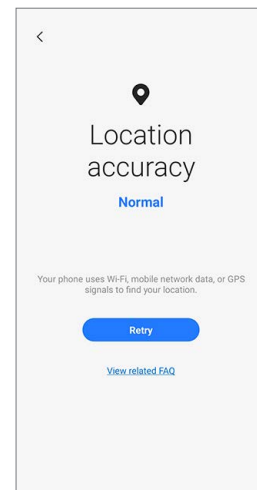

Wi-Fi

- Function: Check whether Wi-Fi can search for Wi-Fi routers.
- Provided information
 - Status: View whether the feature is working normally.
 - Available networks: View the number of available networks.
 - Signal strength: View the signal strength of the connected Wi-Fi router.
 - Networks: View available networks.
 - History: View the Wi-Fi control history.



To test this feature, the Wi-Fi feature must be activated.

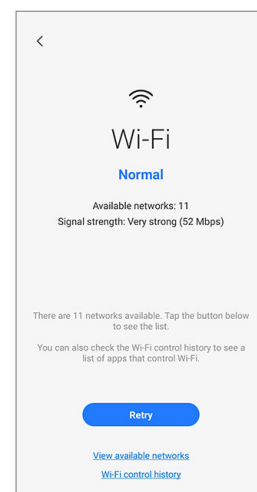

Bluetooth

- Purpose: Check whether Bluetooth can search for other Bluetooth devices.
- Provided information
 - Status: View whether the feature is working normally.
 - FAQ: View frequently asked questions.



To test this feature, the Bluetooth feature must be activated.

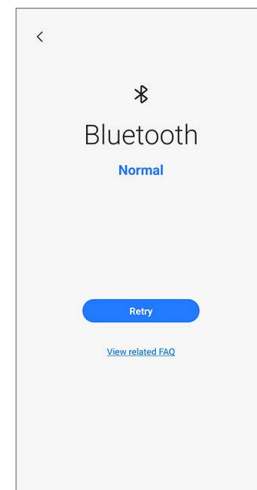

Fingerprint recognition

- Purpose: Check whether the fingerprint recognition sensor is working.
- How to check:
Place your finger on the fingerprint recognition sensor.
- Provided information
 - Status: View whether the feature is working normally.



To test this feature, your fingerprint must be registered.

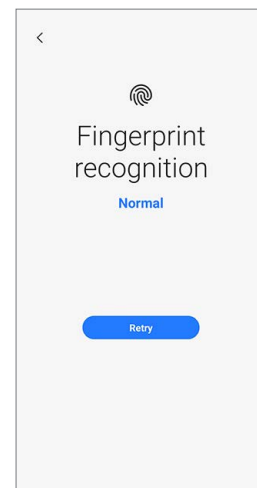

Face recognition

- Purpose: Check whether the face recognition sensor is working.
- How to check:
Look at the screen.
- Provided information
 - Status: View whether the feature is working normally.
 - FAQ: View frequently asked questions.

 To test this feature, your face must be registered.

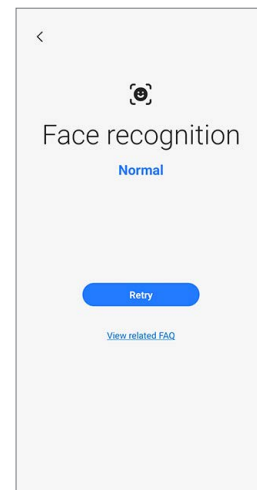

Wired headphones

- Purpose: Check whether the headphone jack recognises the headphones normally.
- How to check:
 - 1) Connect headphones to your device.
 - 2) Tap **Play** and listen for the sound.
 - 3) Answer the question using the buttons.
- Provided information
 - Status: View whether the feature is working normally.

 To test this feature, you must connect headphones.

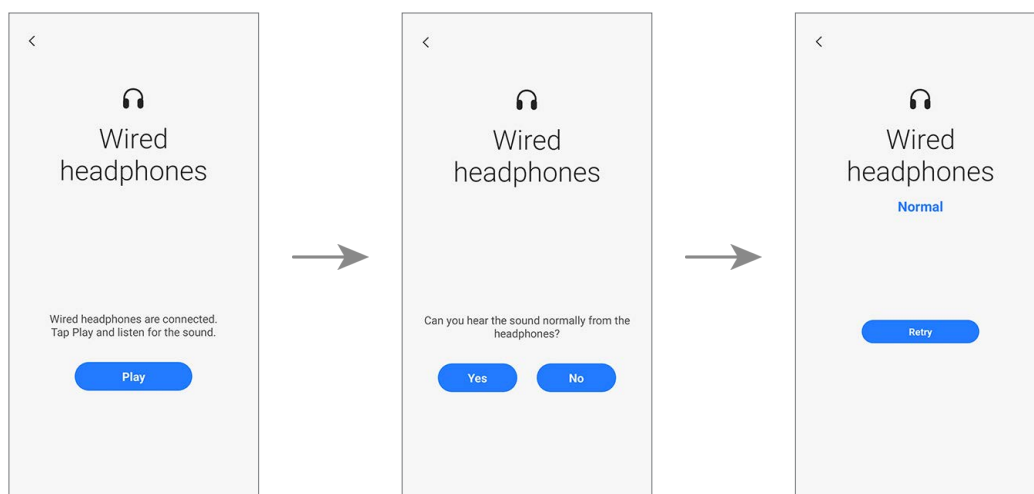

S Pen

- Purpose: Check whether the S Pen is recognised in all areas of the touchscreen.
- How to check:
 - 1) Tap all the rectangles on the screen with the S Pen.
The tapped or dragged rectangles will turn blue.
 - 2) Hover the S Pen over the screen and move from A to B.
The blue circle will move along with the S Pen.
- Provided information
 - Status: View whether the feature is working normally.
 - S Pen features: View the status of S Pen features.
 - FAQ: View frequently asked questions.
-  Make sure that the screen is clean to get more accurate test results.
- This test is only available for the S Pen supported models.

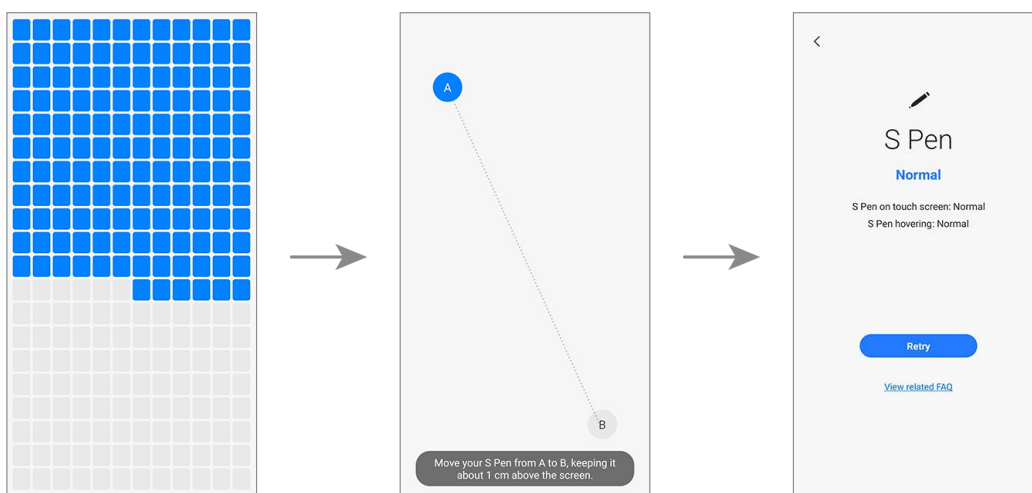

USB connection

- Purpose: Check whether the multipurpose jack recognises the USB cable normally.
- How to check:
Connect any USB cable to your device.
- Provided information
 - Status: View whether the feature is working normally.
 - FAQ: View frequently asked questions.



To test this feature, the USB cable must be connected to a computer.

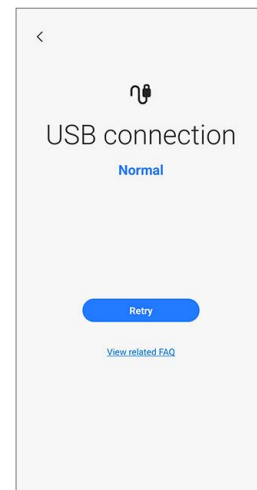

Cable charging

- Purpose: Check whether the multipurpose jack recognises the charger normally.
- How to check:
Connect a charger to your device.
- Provided information
 - Status: View whether the feature is working normally.
 - Charging speed: View the charging speed according to the charger you connected.



Use only Samsung-approved chargers.

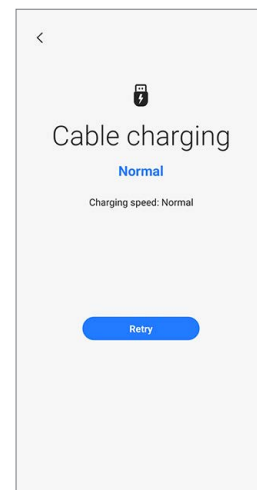

Wireless charging

- Purpose: Check whether the wireless charging feature is working normally.
- How to check:
Put your device on a wireless charger.
- Provided information
 - Status: View whether the feature is working normally.
 - Charging speed: View the charging speed according to the wireless charger you put your device on.



Use only Samsung-approved wireless chargers.

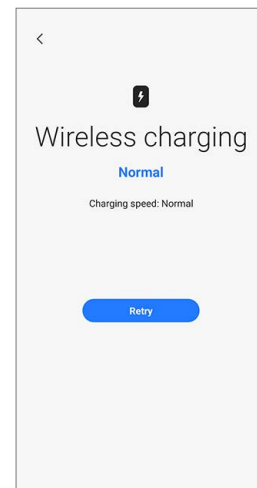

Battery status

- Function: Check the battery values and analysis.
- Provided information
 - Status: View whether the feature is working normally.
 - Life: View the remaining battery life (measured by comprehensive battery values).
 - Capacity: View the battery capacity.
 - FAQ: View frequently asked questions.

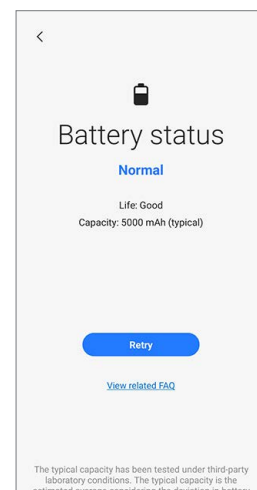

Calibrations

Calibrations

In order to guarantee the stable and correct performance of components or sensors, it is required to conduct calibrations through the **Self Repair Assistant** app after repair.

If the calibration results show any malfunctions, visit a Samsung Service Centre for further action. Any malfunctions caused by your repair may incur additional repair charges.

 In order to conduct the accurate calibrations after repair, visit a Samsung Service Centre or website to buy calibration equipment if you do not have any.

Used Parts and Calibration Functions in Supported Models

The calibration functions are automatically conducted based on the selected parts.

	Screen	Battery	Back Glass	Charging Port	Speaker
Optical Fingerprint Cal.	Yes	No	No	No	No
Range Sensor Cal.	Yes	Yes	Yes	Yes	Yes
Battery Cycle Resets.	No	Yes	No	No	No
Touch Screen Panel Cal.	Yes	No	No	No	No
Speaker Cal.	No	No	No	No	Yes
Under-display Camera Cal.	Yes	No	No	No	No
Digital Hall Sensor Cal.	Yes	No	No	No	No

- Depending on the model, the screen module may include batteries. So when the screen module is replaced, the battery also has to be selected and a battery cycle reset must be performed.
- In the Fold models, touch screen panel calibration is performed for both the main and cover screens.
- Digital hall sensor calibration is only for the Fold and Flip models and under-display camera calibration is only for the Fold models.

Using the Self Repair Assistant App

1 Download the **Self Repair Assistant** app from **Galaxy Store**.

- For US devices, you need to install the APK file for the **Self Repair Assistant** app manually. However, if the **Auto Blocker** function which is provided from Android OS 14 (U OS) is turned on, you cannot install any APK files manually through the **My Files** app. In this case, launch the **Settings** app, tap **Security and privacy** → **Auto Blocker**, and then tap the switch to turn it off to install the **Self Repair Assistant** app.

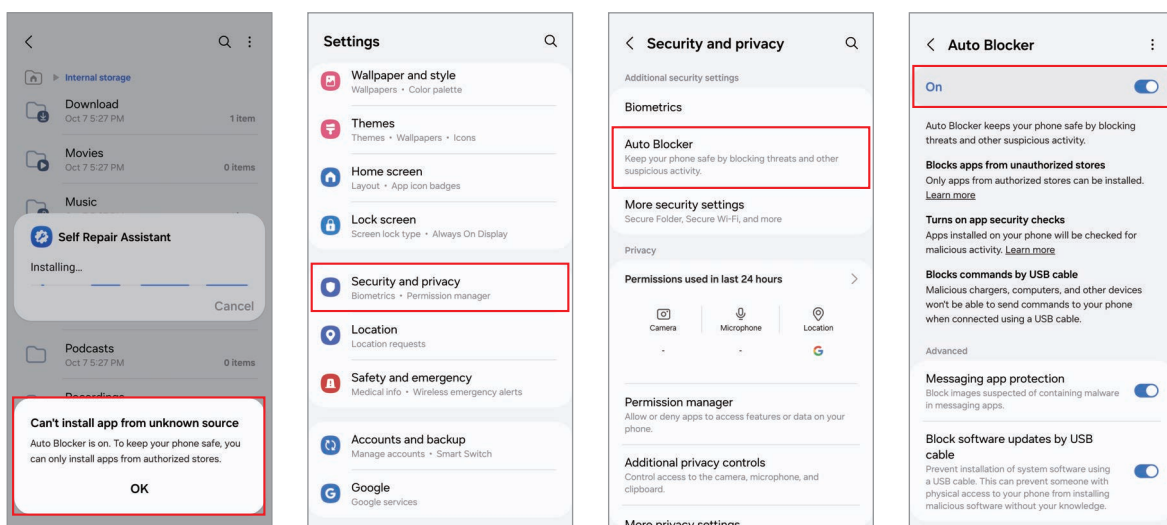

2 Launch the **Self Repair Assistant** app.

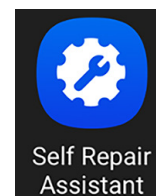

3 Read Privacy Notice and tap **Continue**.

- If you are not signed in to your Samsung account, a button will appear to sign in.
- If you select the link to read the full Privacy Notice, you will be directed to our site.

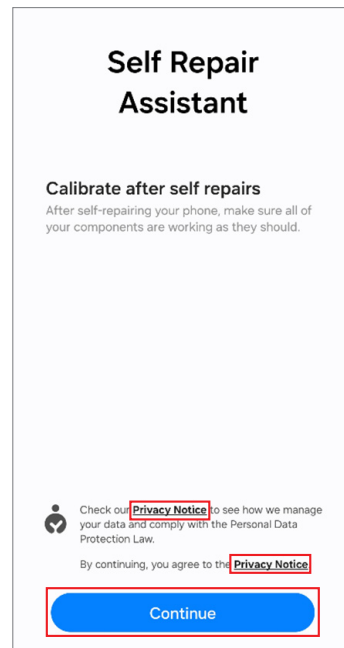
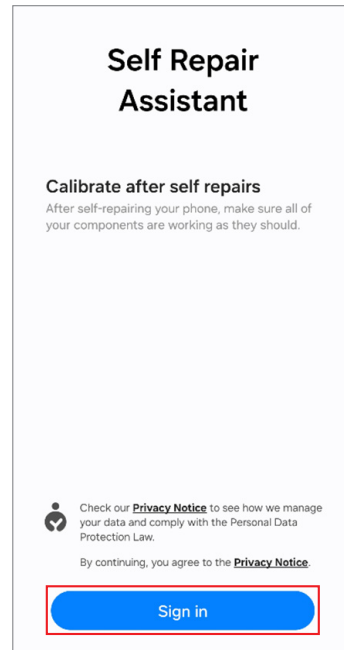

4 Check permissions and tap **Continue**.

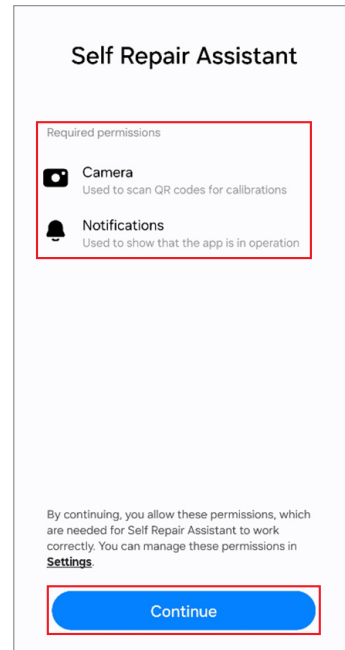

5 Select the part that you have replaced and tap **Next**.



- The required calibrations will be conducted automatically.
- If the device does not have certain components or sensors associated with the part that has been replaced, relative calibration will be skipped automatically.

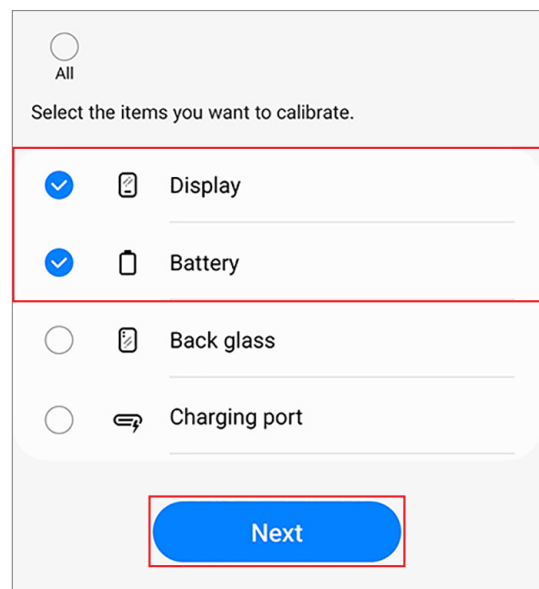

6 Read the on-screen instructions and tap **Start**.

 Refer to [Optical Fingerprint Sensor Calibration](#), [Resetting the Battery Cycle Count](#), [Range Sensor Calibration](#), [Touch Screen Panel Calibration](#), [Speaker Calibration](#), [Under-display Camera Calibration \(Fold Models Only\)](#), and [Digital Hall Sensor Calibration \(Fold and Flip Models Only\)](#) for more information.

Optical fingerprint sensor calibration

This calibration is needed after replacing the phone's screen.

You'll need to place different colored rubber squares on the screen when prompted.

Start

Skip

Camera range sensor calibration

This calibration needs to be done in the dark. Move to a dark room before starting this calibration.

Start

Skip

7 Check the results of each calibration item.

- **Completed:** Calibration was done normally.
- **Failed:** Calibration failed.
- **Skipped:** Calibration was skipped.

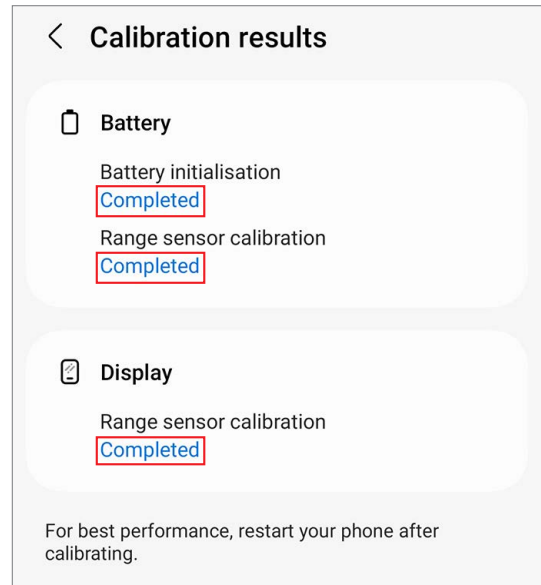

8 On the calibration results page, tap **Close** to close the app.

Restart your device to finish calibrating.

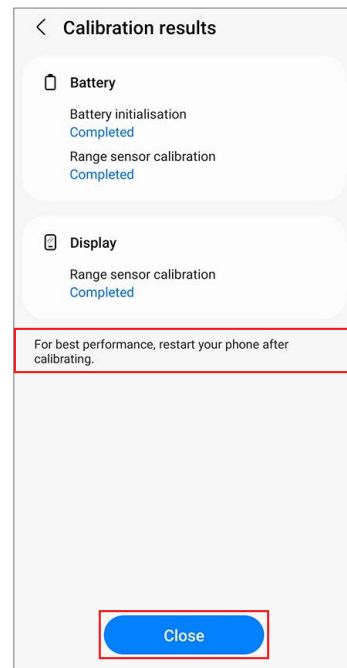

Optical Fingerprint Sensor Calibration

Whenever the screen is replaced, the optical fingerprint sensor must be calibrated to guarantee optimised fingerprint sensor performance for devices that have it.

Optical fingerprint sensor calibration is available through the **Self Repair Assistant** app.



- This feature may not be available depending on the model. The availability of this feature can be automatically checked in the Self Repair Assistant app, so please follow the guidance of the Self Repair Assistant app.
- Three rubbers (the white calibration box, the black calibration box, and the 3D fingerprint dummy rubber) are required to start this calibration.

White calibration box

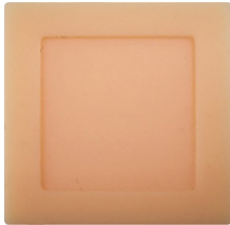

Black calibration box



3D fingerprint dummy rubber



1 Launch the **Self Repair Assistant** app.

2 Tap **Display** → **Next**.



- The required calibration or test items will be processed automatically.
- If the device does not have certain components or sensors associated with the part that has been replaced, relative calibration will be skipped automatically.

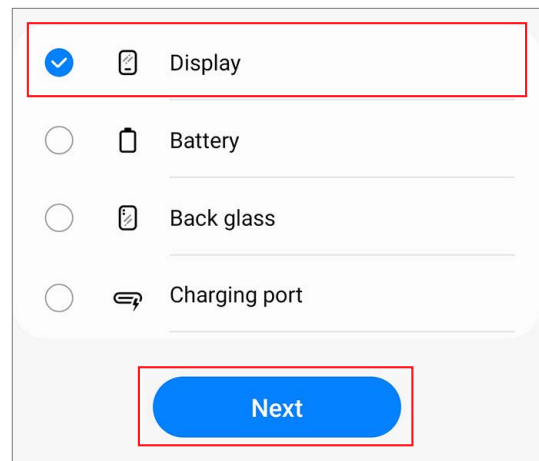

- 3 Check the part and calibration and then tap **Start**.

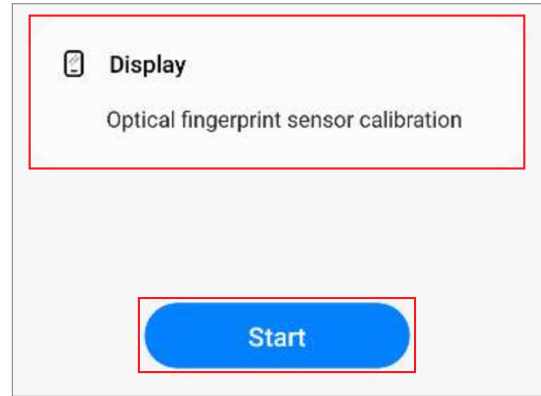

- 4 Read the on-screen instructions and tap **Start**.

-  The white calibration box must be prepared before you start.

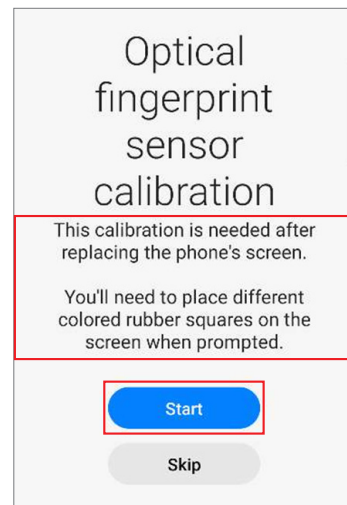

- 5 Put the white calibration box on the sensor area (below the square side) and push the rubber by applying force with your finger. Tap **Next** and keep pushing the rubber with your finger until you see the success message.

-  The bottom side of the rubber that is shaped like a square should be located on the square guide line.

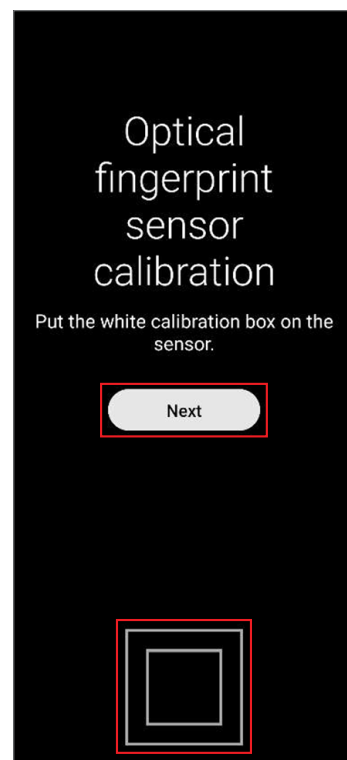
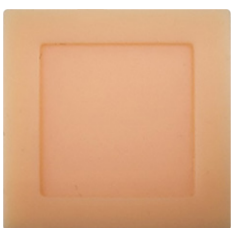

- 6 Put the black calibration box on the sensor area (below the square side) and push the rubber by applying force with your finger. Tap **Next** and keep pushing the rubber with your finger until you see the success message.

- ✍ • The black calibration box must be prepared before you start.
- The bottom side of the rubber that is shaped like a square should be located on the square guide line.

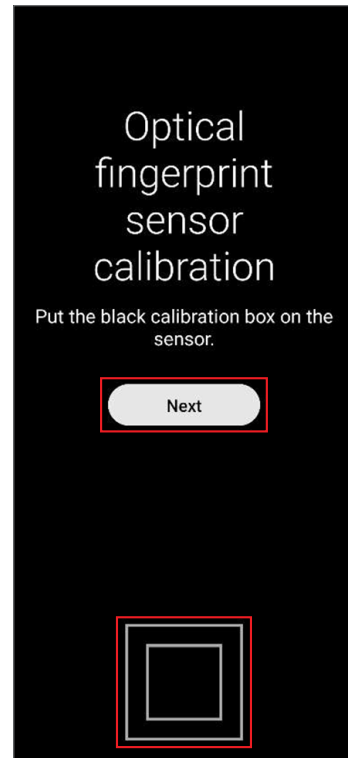

- 7 Put the 3D fingerprint dummy rubber on the sensor area (below the square side) and push the rubber by applying force with your finger. Tap **Next** and keep pushing the rubber with your finger until you see the success message.

- ✍ • The 3D fingerprint dummy rubber must be prepared before you start.
- The bottom side of the rubber that is shaped like a square should be located on the square guide line. (Do not place the pattern horizontally on the 3D fingerprint dummy rubber.)

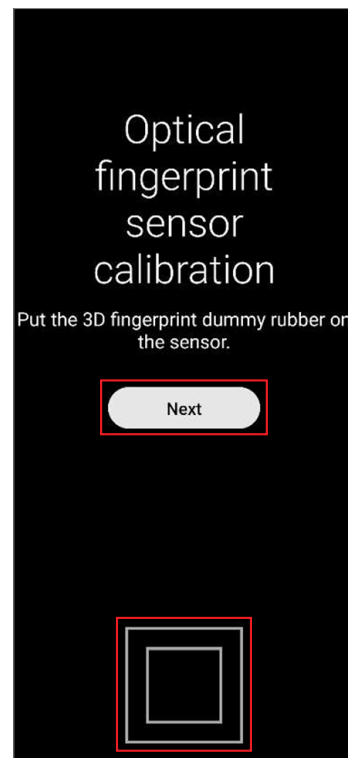

8 Check the result of the calibration.

 **Completed** appears only when the calibration is successfully completed. If **Completed** does not appear, try calibrating again.

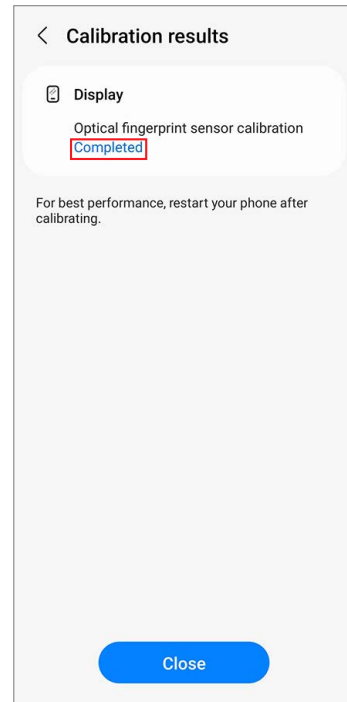

Resetting the Battery Cycle Count

The battery cycle count should be reset whenever your device's battery is replaced.

- 1 Launch the **Self Repair Assistant** app.
- 2 Select the part that you have replaced. Tap **Battery** → **Next**.

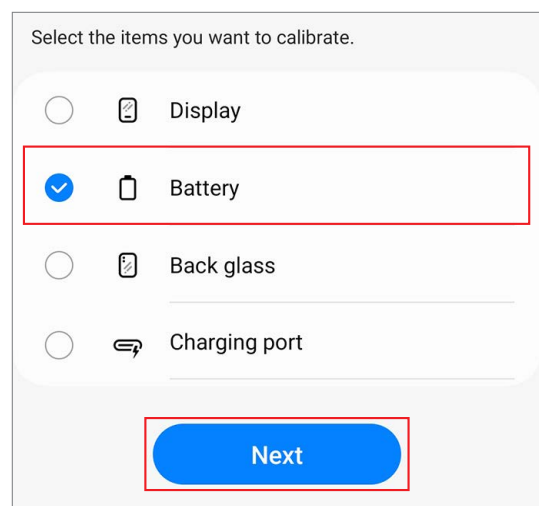

3 Check part and calibration and tap **Start**.

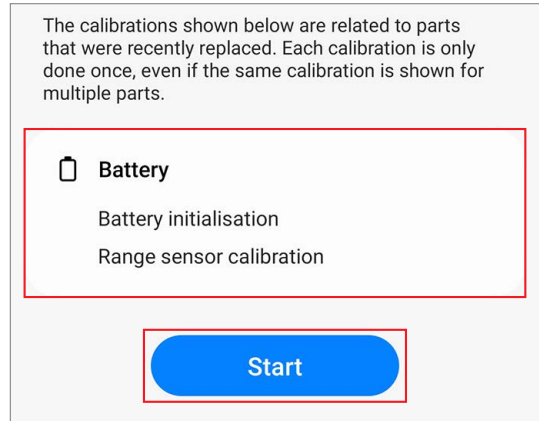

4 Tap **Start**.

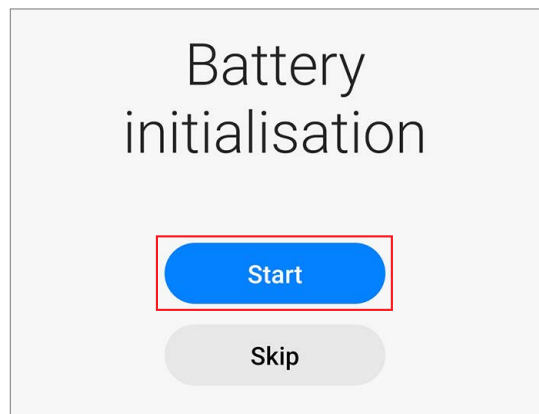

5 Read the on-screen instructions and tap **Scan** to scan the QR code, or tap **Enter manually** to enter the serial number manually.

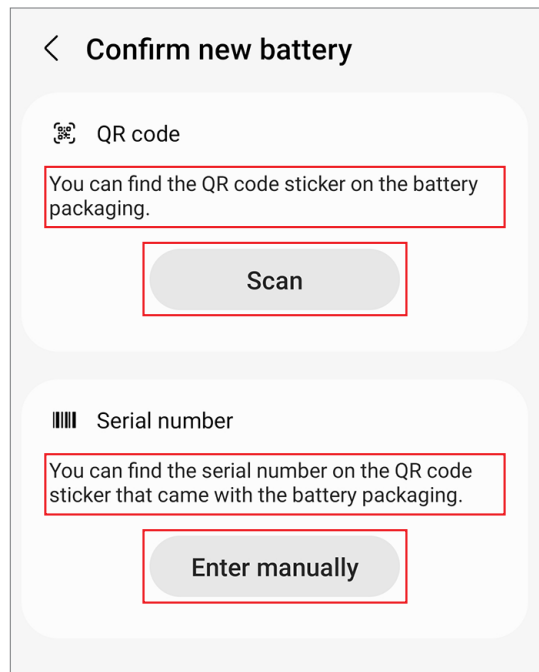

- 6 Scan the QR code or enter the serial number that appears on the battery package.
The reset will begin.

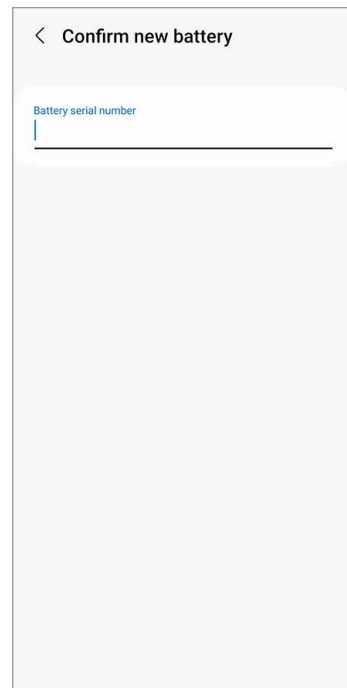
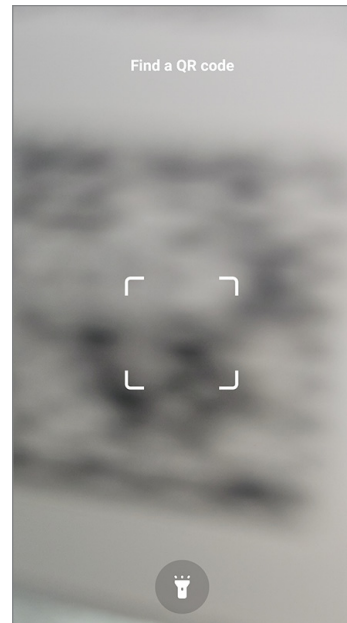

- 7 Check the calibration results.

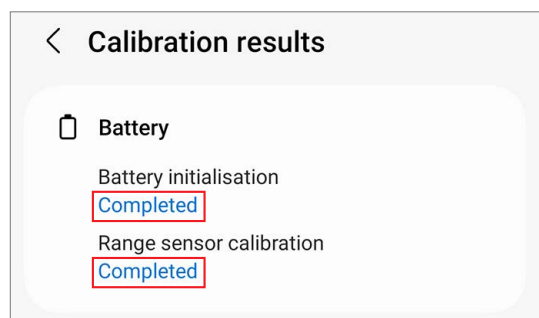

Range Sensor Calibration

When replacing screens, batteries, back glasses, or charging ports, range sensor calibration is required to ensure the range sensors of devices equipped with them are optimised.

Range sensor calibration is available through the **Self Repair Assistant** app.

 Some content may differ from your device depending on the region, service provider, model specifications, or device's software.

- 1 Launch the **Self Repair Assistant** app.
- 2 Select the part that you have replaced and tap **Next**.

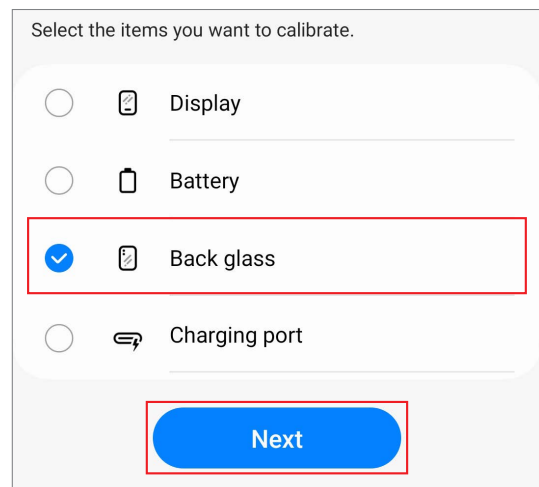

- 3 Check part and calibration and tap **Start**.

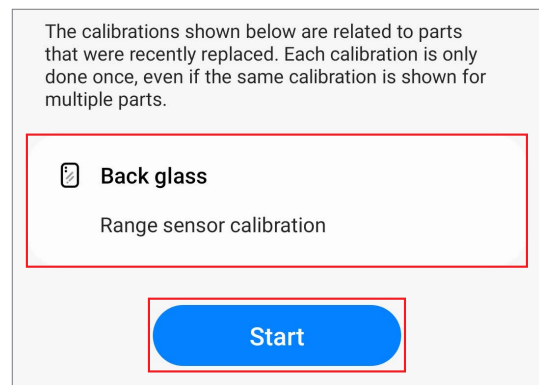

- 4 Read the on-screen instructions and tap **Start**.

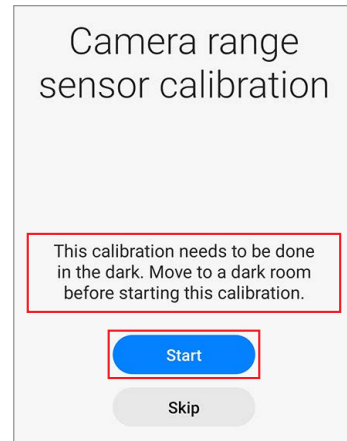

- 5 In a dark room or area, place the phone face-down, then press the Volume button.

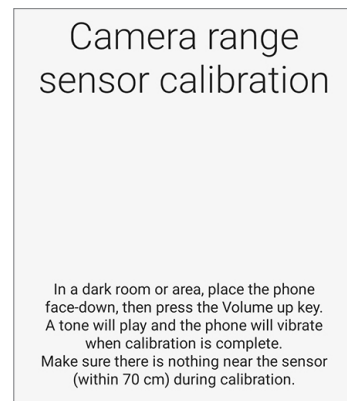

- 6 The calibration will perform automatically. A tone will play when calibration is complete.

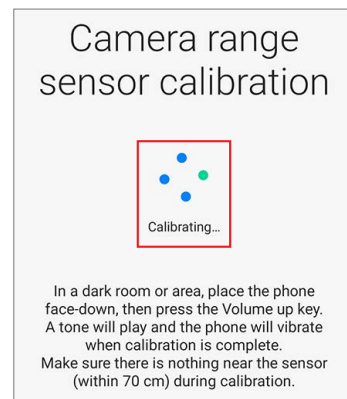

- 7 Check the calibration result.

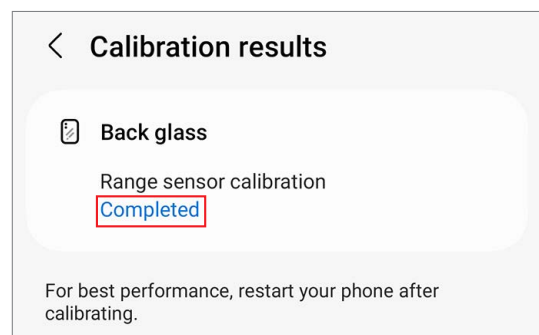

Touch Screen Panel Calibration

When replacing screens, touch screen panel calibration is required to ensure accurate touch input.

Touch screen panel calibration is available through the **Self Repair Assistant** app.

 In the Fold models, touch screen panel calibration is performed for both the main and cover screens.

- 1 Launch the **Self Repair Assistant** app.
- 2 Select the part that you have replaced and tap **Next**.

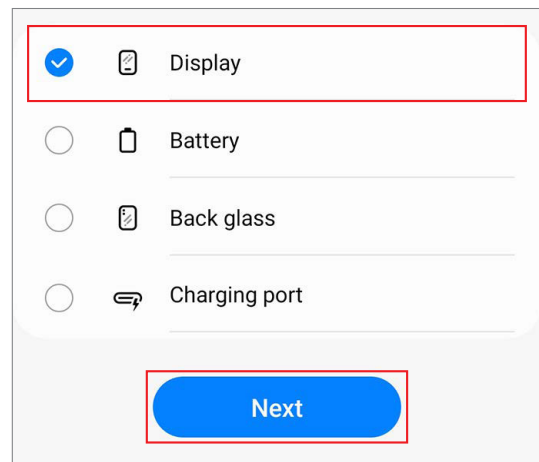

- 3 Check part and calibration and tap **Next**.

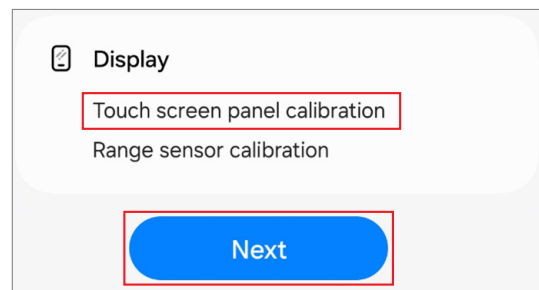

- 4 Read the on-screen instructions and tap **Start**.

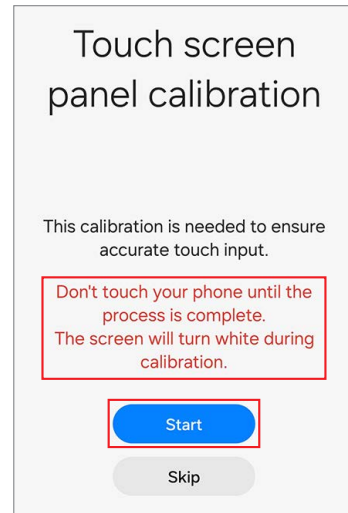

- 5 The calibration will perform automatically and the screen will turn white during calibration.

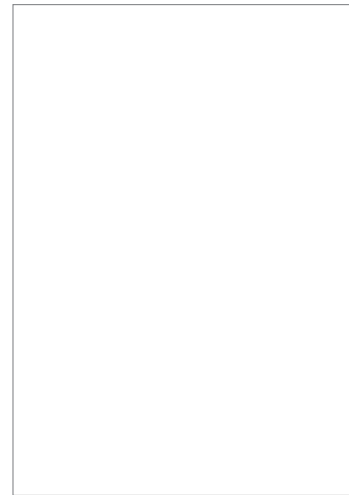

- 6 Check the calibration result.

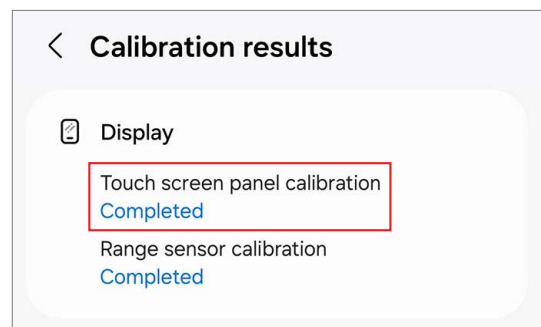

Speaker Calibration

When replacing speakers, the speaker must be calibrated to guarantee optimised speaker performance for devices that have it.

Speaker calibration is available through the **Self Repair Assistant** app.

- 1 Launch the **Self Repair Assistant** app.
- 2 Select the part that you have replaced and tap **Next**.

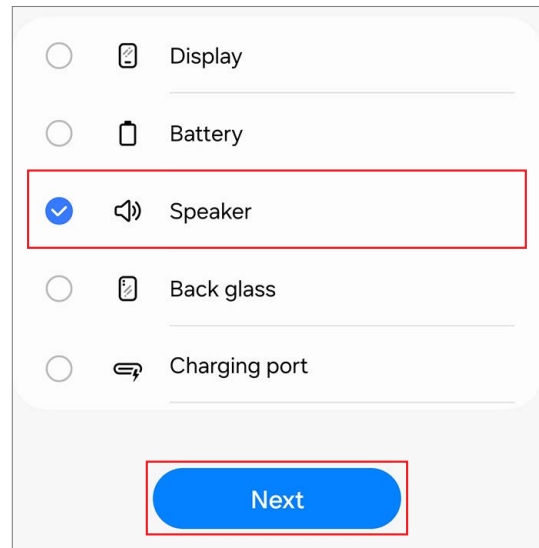

- 3 Check part and calibration and tap **Next**.

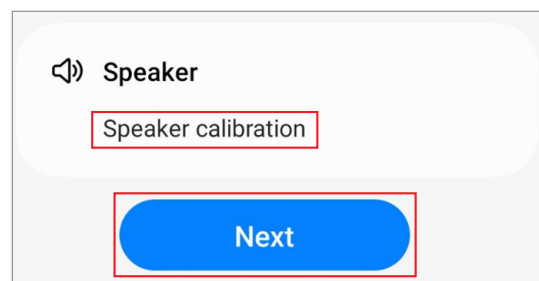

4 Tap **Start**.

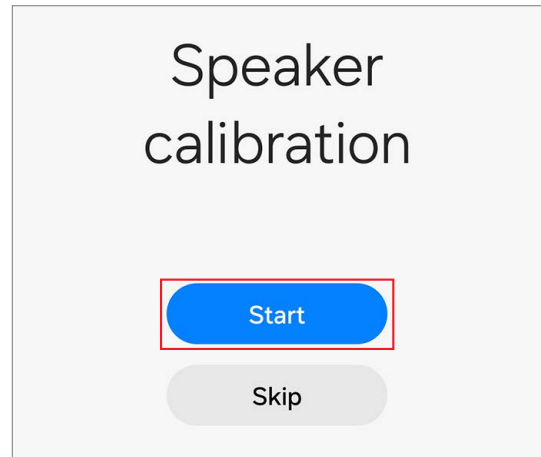

5 The calibration will perform automatically.

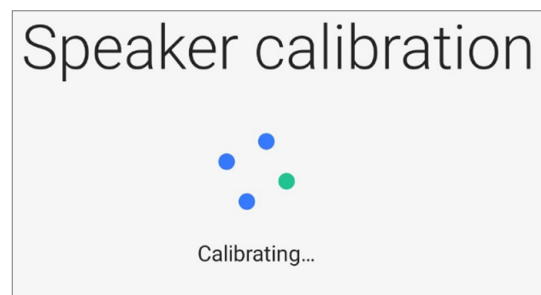

6 Check the calibration result.

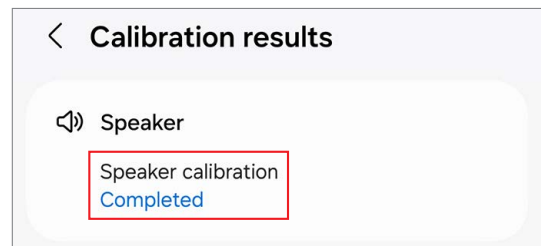

Under-display Camera Calibration (Fold Models Only)

Whenever the screen is replaced, the under-display camera must be calibrated to guarantee optimised under-display camera performance for devices that have it.

Under-display camera calibration is available through the **Self Repair Assistant** app.

 This feature may not be available depending on the model. The availability of this feature can be automatically checked in the Self Repair Assistant app, so please follow the guidance of the Self Repair Assistant app.

- 1 Launch the **Self Repair Assistant** app.
- 2 Select the part that you have replaced and tap **Next**.

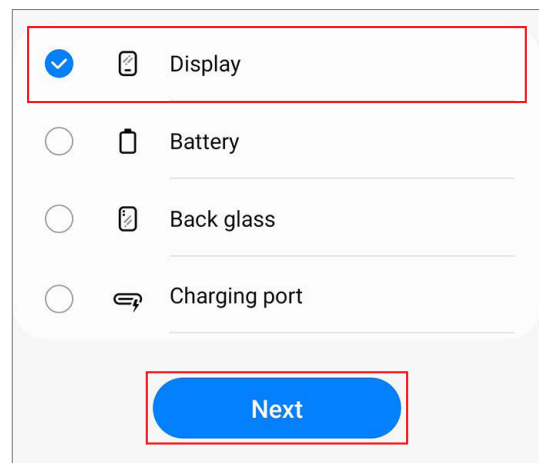

- 3 Check part and calibration and tap **Next**.

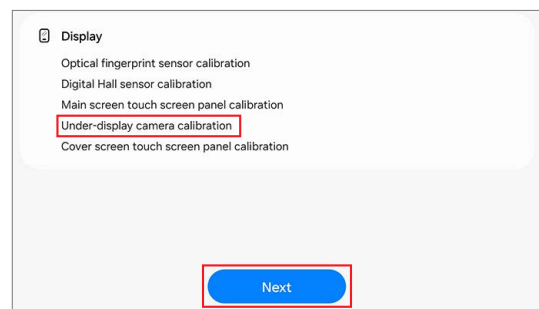

4 Tap **Start**.

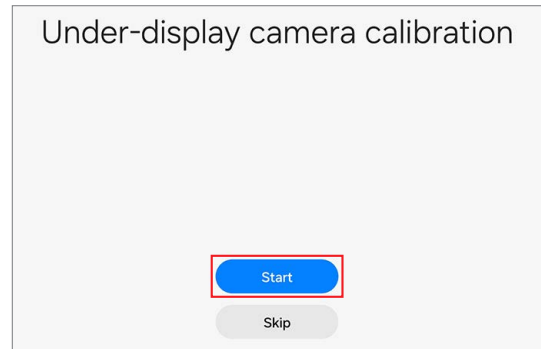

5 The calibration will perform automatically.

6 Check the calibration result.

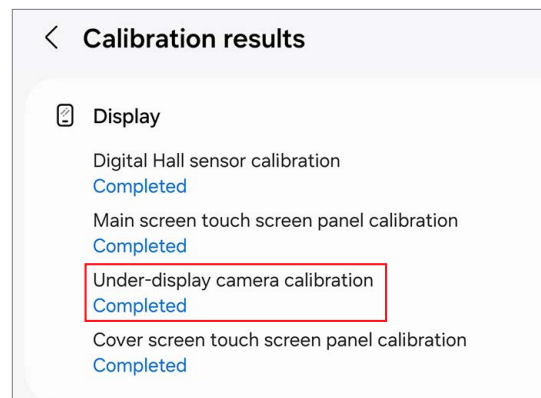

Digital Hall Sensor Calibration (Fold and Flip Models Only)

Whenever the screen is replaced, the digital hall sensor must be calibrated to guarantee optimised digital hall sensor performance for devices that have it.

Digital hall sensor calibration is available through the **Self Repair Assistant** app.



- This feature may not be available depending on the model. The availability of this feature can be automatically checked in the Self Repair Assistant app, so please follow the guidance of the Self Repair Assistant app.
- **For Fold models:** If the main screen does not turn on after being replaced (the main screen is off and the cover screen is on when the device is unfolded), follow the steps below to perform digital hall sensor calibration. The boot screen (the screen where the Samsung and carrier logos appear) will appear normally and then turn off, so it is not a hardware failure.

- 1) Fold the device and launch the **Self Repair Assistant** app on the cover screen.
- 2) Move to the digital hall sensor calibration screen, unfold the device, and then press the Volume Up button or the Volume Down button.
- 3) You will hear a vibration, and the calibration will be performed automatically.

When calibration is complete, the main screen will turn on normally.

- **For Flip models:** If the main screen does not turn on after being replaced (the main screen is off and the cover screen is on when the device is unfolded), follow the steps below to force the main screen to turn on and perform digital hall sensor calibration. The boot screen (the screen where the Samsung and carrier logos appear) will appear normally and then turn off, so it is not a hardware failure.
- 1) Connect the USB cable to the device, and connect the other end of the USB cable to the USB power adapter or your computer.
 - 2) While pressing and holding the Side button, press the Volume Up button once and the Volume Down button twice.
 - 3) When the main screen turns on, perform digital hall sensor calibration.

- 1 Launch the **Self Repair Assistant** app.
- 2 Select the part that you have replaced and tap **Next**.

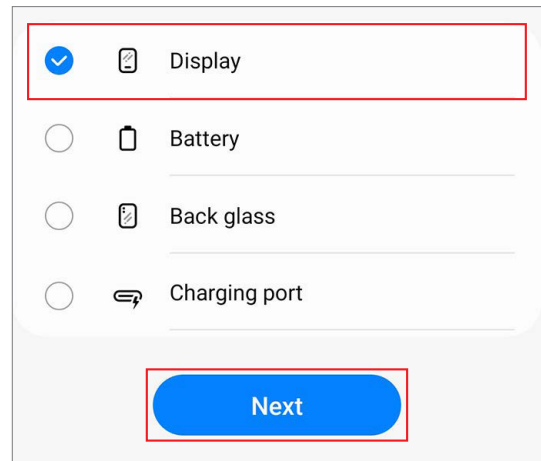

- 3 Check part and calibration and tap **Next**.

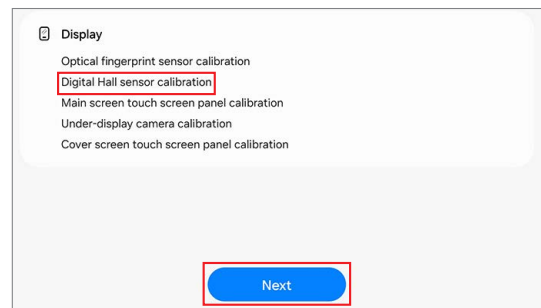

- 4 Tap **Start**.

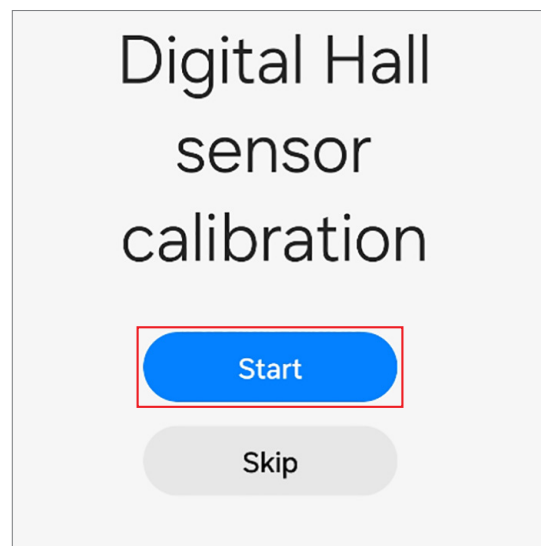

5 The calibration will perform automatically.

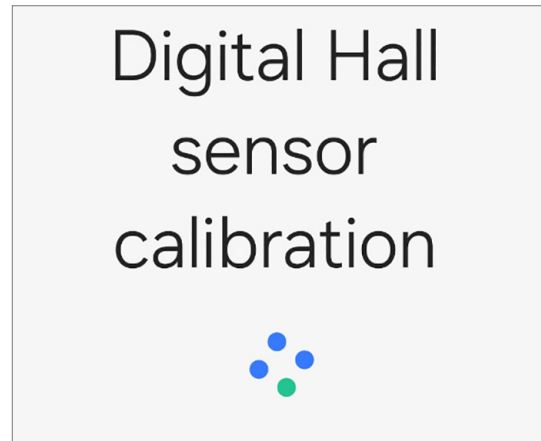

6 Check the calibration result.

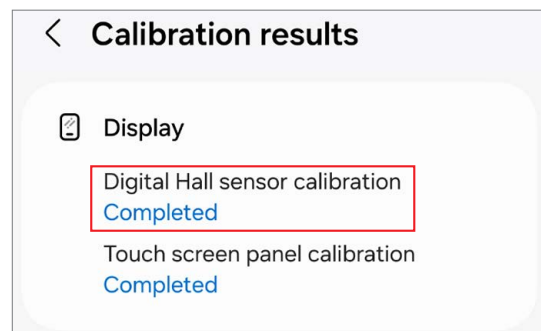

Exploded View and Parts List

 The product's composition may vary depending on the country, region, or carrier.

Exploded View

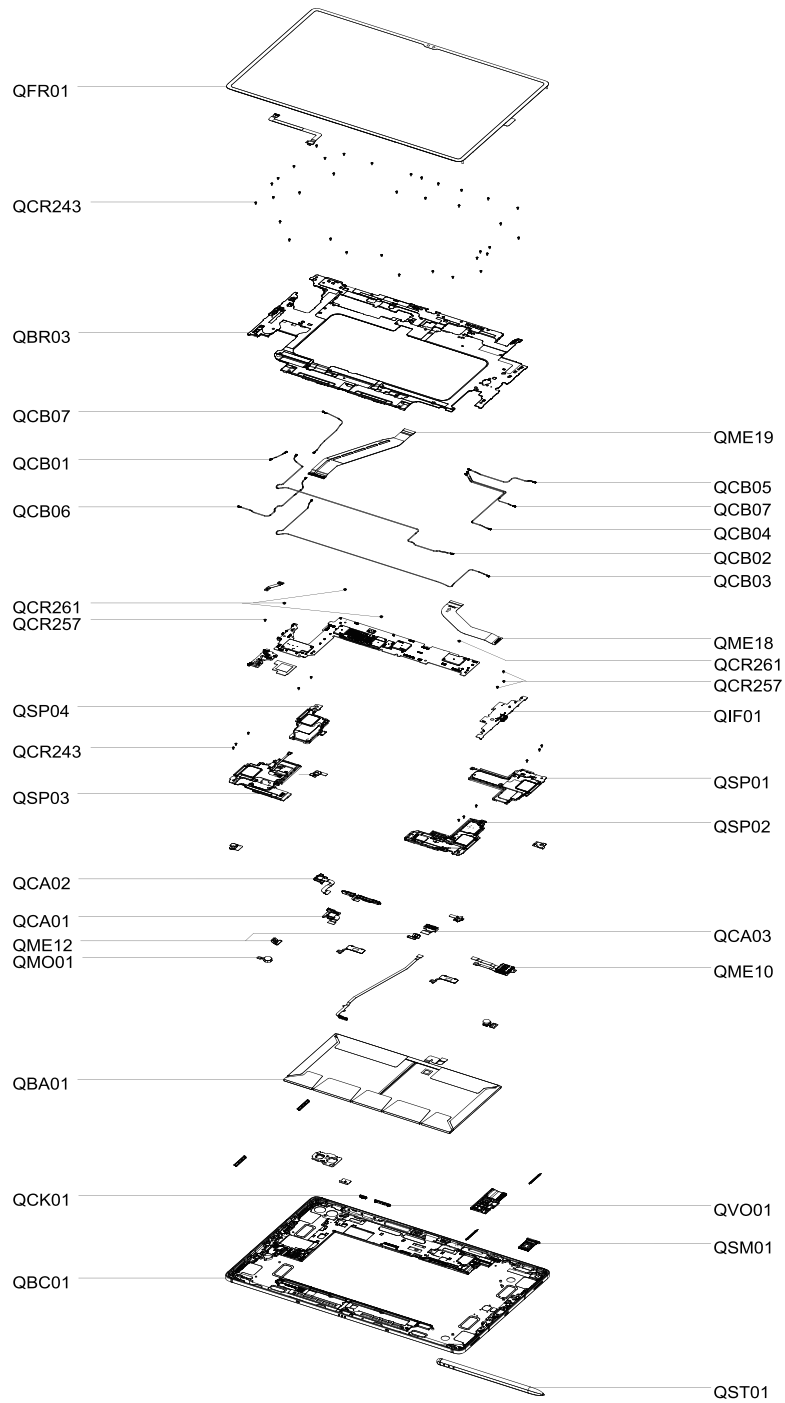

Parts List

Number	Name
QCR243	Screw 3405
QCR261	Screw 3463
QME19	Main Flex Cable (Screen to PBA)
QCR257	Screw 3443
QMO01	Vibrator Motor
QCB01	Antenna Flex Cable (Red)
QCB05	Antenna Flex Cable (Grey)
QCB07	Antenna Flex Cable (Orange)
QCB06	Antenna Flex Cable (Black)
QCB03	Antenna Flex Cable (White)
QCB02	Antenna Flex Cable (Blue)
QCB04	Antenna Flex Cable (Red)
QME10	SIM Card Socket
QME18	Main Flex Cable (Sub PBA to PBA)
QCK01	Side Button
QVO01	Volume Button
QST01	S pen
QCA03	Front Camera
QCA02	Rear Camera (Ultra Wide)
QCA01	Rear Camera (Wide)
QBR03	Bracket
QME12	Microphone
QSM01	SIM Card Tray
QBC01	Back cover module
QIF01	Charging Port





Number	Name
QSP04	Speaker2
QSP03	Speaker1
QSP02	Speaker4
QSP01	Speaker3
QFR01	Screen
QBA01	Battery









Disassembly and Assembly



Tools for Disassembly and Assembly



When repairing devices, you absolutely must wear protective equipment for your safety.



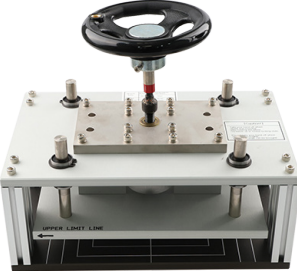

-  Availability of rental services for toolkits with a complete set of tools for self repair service may vary depending on the country and is currently available only in limited countries.

Tool & Part Code	Image	Description
Safety Goggles		Prevents accidents during repair (protective equipment)
Safety Gloves (ESD safe, cut-resistant)		Prevents accidents during repair (protective equipment)
Safety Mask		Prevents accidents during repair (protective equipment)
Anti-static Wrist Strap		Prevents electrostatic damage (recommended)

Tool & Part Code	Image	Description
ESD Safe Mat	 A black roll of ESD safe mat with a grey surface, partially unrolled. A black wrist strap with a yellow plug and a yellow probe are resting on the mat.	Prevents electrostatic damage (recommended)
Ejection Pin	 A blue plastic ejection pin with a looped handle and a long, thin pin.	Pin for ejecting the SIM card tray
Cross-head Screwdriver	 A black cross-head screwdriver with a long, thin shaft.	Tool for screwing in cross-head screws
Opening Pick	 A black, triangular opening pick.	Tool for disassembling the screen and other parts
Opening Tool (L)	 A black, curved opening tool.	Tool for disassembling the screen
Opening Tool	 A black, straight opening tool.	Tool for disassembling the connector and other parts
Suction Cup (L)	 A red suction cup with a handle and a central opening.	<p>Tool for disassembling the screen and other parts</p> <p> When removing the screen of Galaxy Tab S10 Ultra, you need a large size suction cup.</p>





Tool & Part Code	Image	Description
ESD Safe Tweezers and Round Tip Metal Tweezers		<p>Tool for handling connectors, cables, and other parts</p> <ul style="list-style-type: none"> Because it is possible to damage parts or components when using sharp tweezers, use tweezers made with plastic or rubber material. When removing a vibrator motor, it is required to use the round tip metal tweezers.
Heating Bag		<p>Tool for disassembling the screen and other parts</p> <ul style="list-style-type: none"> When removing the screen of Galaxy Tab S10 Ultra, you need the 2 heating bags.
Press Fixture		<p>Tool for pressing the screen or battery</p> <ul style="list-style-type: none"> This tool is available to use by the rental of tool kit that contains a complete set of the tools for self repair service.



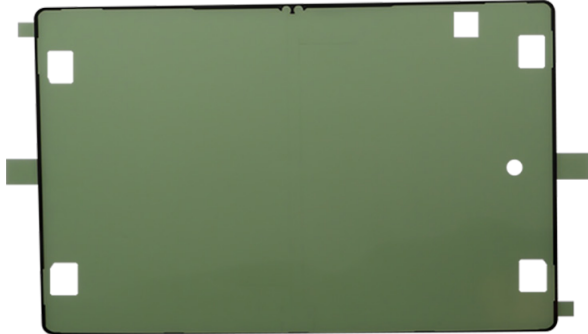

Tool & Part Code	Image	Description
Bottom Press Tray		<p>Tool to place the device when pressing the screen or battery using the press fixture</p> <ul style="list-style-type: none"> ✍ <ul style="list-style-type: none"> • This tool is available to use by the rental of tool kit that contains a complete set of the tools for self repair service. • This tray can be used in common with other models, so the labeled model name on tray may differ.
Top Press Tray		<p>Tool to cover the bottom press tray when pressing the screen using the press fixture</p> <ul style="list-style-type: none"> ✍ <ul style="list-style-type: none"> • This tool is available to use by the rental of tool kit that contains a complete set of the tools for self repair service. • This tray can be used in common with other models, so the labeled model name on tray may differ.



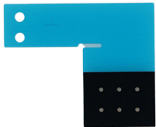

Tool & Part Code	Image	Description
Battery Rubber Pad		<p>Tool to cover the battery when pressing the battery using the press fixture</p> <p> This tool is available to use by the rental of tool kit that contains a complete set of the tools for self repair service.</p>
Calibration Rubber for Optical Fingerprint Sensor		<p>Tool to calibrate the optical fingerprint sensor after replacing the screen</p> <p> This tool is available to use by the rental of tool kit that contains a complete set of the tools for self repair service.</p>



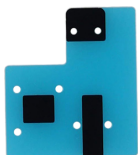

Fasteners (Adhesives and Materials) for Assembly

The fasteners composition may vary depending on the repair parts, country, region, or carrier.

Item	Quantity	Image	Description
Screen Adhesive Tape GH81-23920A	1		Double sided adhesive tape for attaching the screen
Screen Left Adhesive Tape GH81-26674A	1		Double sided adhesive tape attached to the left of the bracket to assemble the screen
Screen Bottom Adhesive Tape GH81-26673A	1		Double sided adhesive tape attached to the bottom of the bracket to assemble the screen
Screen Right Adhesive Tape GH81-26853A	1		Double sided adhesive tape attached to the right of the bracket to assemble the screen

Item	Quantity	Image	Description
Screen Top Adhesive Tape GH81-27034A	1		Double sided adhesive tape attached to the top of the bracket to assemble the screen
Screen Speaker Adhesive Tape GH81-26737A	2		Double sided adhesive tape attached to the speaker 2 and speaker 4 to assemble the screen
Screw 3405 6001-003405	46		Screws for the bracket (35 ea) Screws for the speakers (11 ea)
Screw 3463 6001-003463	4		Screws for the main board (4 ea)
Screw 3443 6001-003443	4		Screws for the charging port (3 ea) Screw for the Wi-Fi board (1 ea)

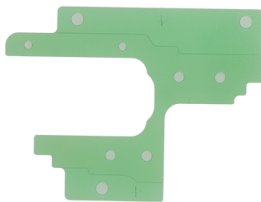
Item	Quantity	Image	Description
SIM Card Socket Adhesive Tape GH81-26565A	1		Double sided adhesive tape for attaching the SIM card socket
SIM Card Socket FPCB Adhesive Tape GH81-23940A	1		Double sided adhesive tape for attaching the FPCB of the SIM card socket
Vibrator Motor Adhesive Tape GH81-21822A	1		Double sided adhesive tape for attaching the vibrator motor
Vibrator Motor FPCB Adhesive Tape GH81-21823A	1		Double sided adhesive tape for attaching the FPCB of the vibrator motor
Rear Wide Camera Adhesive Tape GH81-24005A	1		Double sided adhesive tape for attaching the rear wide camera

Item	Quantity	Image	Description
Rear Ultra Wide Camera Adhesive Tape GH81-24006A	1		Double sided adhesive tape for attaching the rear ultra wide camera
Speaker 1 Adhesive Tape GH02-26213A	1		Double sided adhesive tape for attaching the speaker 1
Speaker 1 FPCB Adhesive Tape GH81-23945A	1		Double sided adhesive tape for attaching the FPCB of the speaker 1
Speaker 2 Adhesive Tape GH02-25113A	1		Double sided adhesive tape for attaching the speaker 2
Speaker 2 FPCB Adhesive tape GH81-23946A	1		Double sided adhesive tape for attaching the FPCB of the speaker 2

Item	Quantity	Image	Description
Speaker 3 Adhesive Tape GH02-26216A	1		Double sided adhesive tape for attaching the speaker 3
Speaker 3 FPCB Adhesive Tape GH81-23944A	1		Double sided adhesive tape for attaching the FPCB of the speaker 3
Speaker 4 Adhesive Tape GH02-26215A	1		Double sided adhesive tape for attaching the speaker 4
Speaker 4 FPCB Adhesive Tape GH81-23943A	1		Double sided adhesive tape for attaching the FPCB of the speaker 4

Disassembly and Reassembly for replacement

-  • The product's composition may vary depending on the country, region, or carrier.
- Repairable parts may vary depending on the country or region.



Before disassembling:

- Unplug and turn off device before disassembling.
- If you have an S Pen purchased separately, remove the S Pen.
- When removing the screen of Galaxy Tab S10 Ultra, you need the 2 heating bags and a large size suction cup.
- Wear an anti-static wrist strap and connect it to the grounded ESD safe mat.

Before reassembling:

- Remove the adhesive tape residues perfectly.
- Prepare all existing screws of this device and adhesive tapes.
- Wear an anti-static wrist strap and connect it to the grounded ESD safe mat.
- Leaving screws inside the device may damage internal components, such as the battery. When assembling, be extra careful not to leave any unassembled screws inside the device.

For all cases of broken glass:

- 1 Wear safety goggles and cut-resistant gloves.
- 2 To prevent injuries and scattering caused by broken glass, attach the tape on the broken glass.
 -  If your device's glass breaks, be careful not to injure your hands or other body parts on debris.
- 3 Press the tape with strong force so that it is strongly attached to the broken glass.
 -  Wait until the adhesive between the tape and the glass is strengthened.
- 4 Follow the disassembly steps in this guide.

SIM Card Tray

Disassembly

Prepare the device to repair by yourself. Insert the ejection pin into the hole of the SIM card tray to loosen the tray and pull out the tray gently from the tray slot.

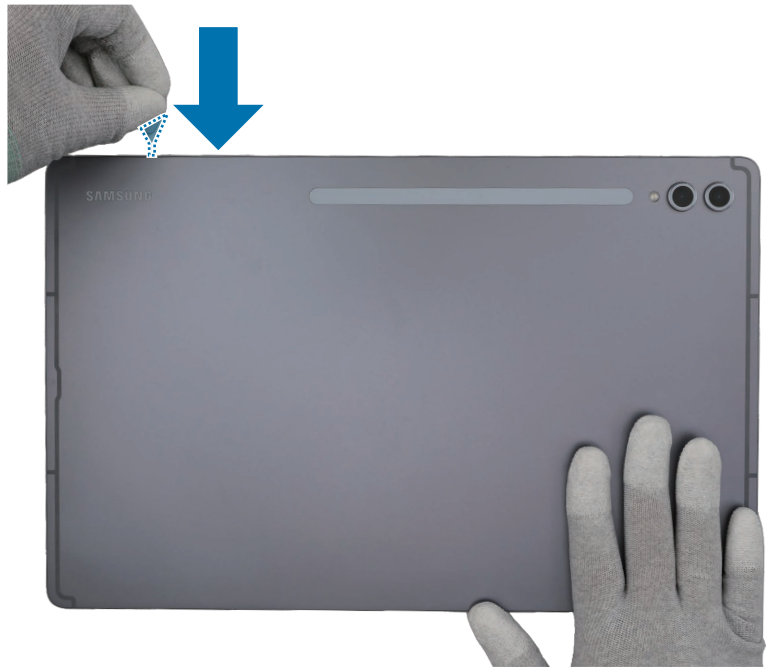



Reassembly





- ⚠ Leaving screws inside the device may damage internal components, such as the battery. During assembly, be extra careful not to leave any unassembled screws inside the device.

Insert the SIM card tray back into the slot. Ensure that there are no abnormalities.



Screen

Disassembly

-  When removing the screen, ensure that the device is fixed on a flat surface.
 -  When removing the screen of Galaxy Tab S10 Ultra, you need the 2 heating bags and a large size suction cup.
- 1 Heat the 2 microwaveable heating bags for 90 seconds in a 700 W microwave and apply each one to the front and back of the top left edge of the device for 4 minutes.
- 
 - It is possible for the device or battery to be damaged by heat.
 - Do not heat the device in a microwave. Doing so could cause an explosion.
 - If your device's glass breaks, the debris can cause injury to your hands or other body parts. For your safety, attach the tape on the broken glass before disassembling the device.
 - 
 - Follow the heating bag's instructions for heating. The recommended time for heating the 2 microwaveable heating bags is 70 seconds for a 1000 W microwave and 90 seconds for a 700 W microwave. (Correct temperature for use: 55-65 °C.)
 - Be careful not to damage the device through excessive heat. (It is recommended to disassemble the device in an area with a temperature gauge.)
 -  If the heating bag is cooled down, heat the microwaveable heating bag additionally, and apply it on the screen to further soften the adhesive. When reheating, it should be heated no longer than 30 seconds. When reheating the 2 heating bags simultaneously, they should be heated no longer than 50 seconds.



2 While maintaining the heating bag under the back of the device, place the suction cup (L) on the top left edge of the screen, and lift it upward carefully.

- ⚠ • As the screen can be damaged by excessive force, be careful not to damage the screen.
- Be careful that the suction cup does not adhere to the area where the tape or sticker is attached.

📌 If you have trouble creating a gap, heat the microwaveable heating bag additionally, and apply it on the screen to further soften the adhesive. When reheating, it should be heated no longer than 30 seconds. When reheating the 2 heating bags simultaneously, they should be heated no longer than 50 seconds.



3 While pulling up the suction cup with steady force to create the gap between the screen and the back cover module, place the opening pick in the gap between the screen and the back cover module and slide the opening pick back and forth along the edge to slice through the adhesive. Repeat the same process of applying the heating bags, placing the suction cup, and the opening pick to separate the screen adhesive from the top left edge, top right edge, left edge, right edge, bottom right edge, and bottom left edge. Then, be cautious with the adhesive on the interior side of the back cover module while gently lifting the screen upwards.

- ⚠ • As the screen can be damaged by excessive force, be careful not to damage the screen.
- As the internal circuitry can be damaged, do not insert the opening pick more than 2 mm.
- ✍ • Make sure to leave the opening pick inserted in the edges to prevent the adhesive from resealing. It is recommended that a large area of the opening pick be inserted.
- If you have trouble creating a gap, heat the microwaveable heating bag additionally, and apply it on the screen to further soften the adhesive. When reheating, it should be heated no longer than 30 seconds. When reheating the 2 heating bags simultaneously, they should be heated no longer than 50 seconds.

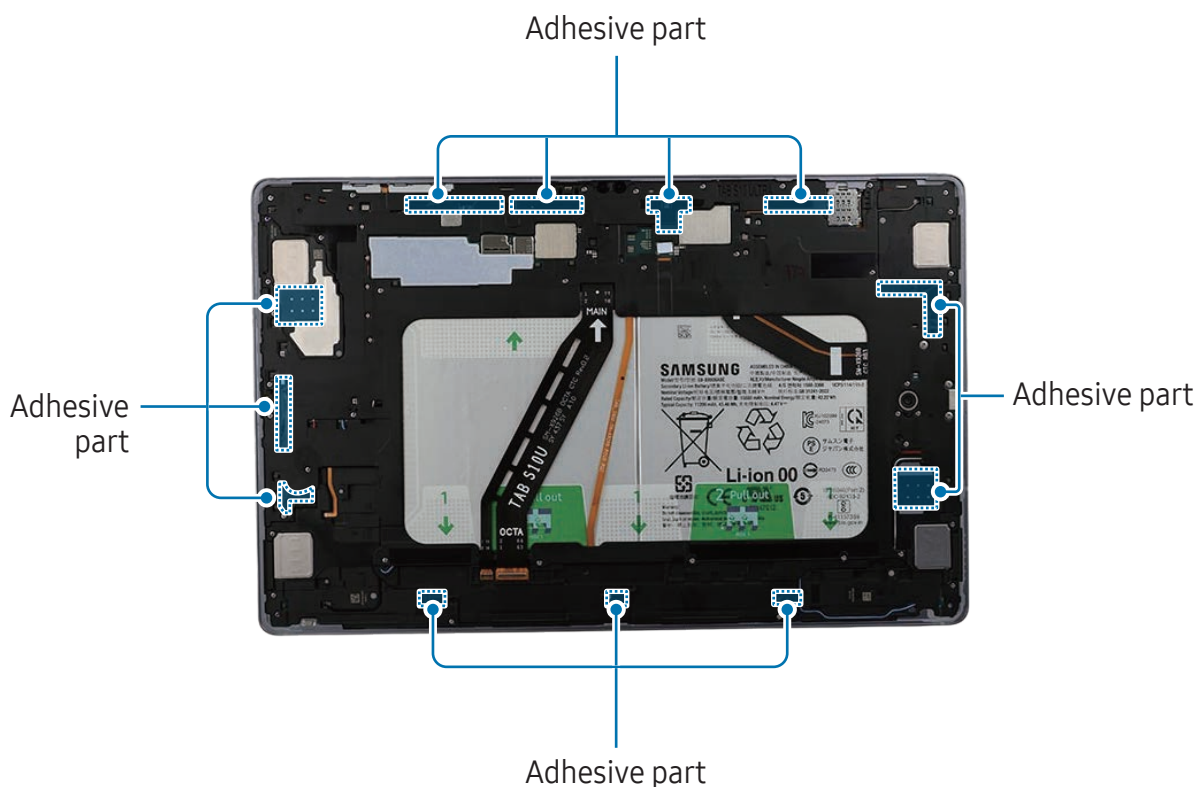

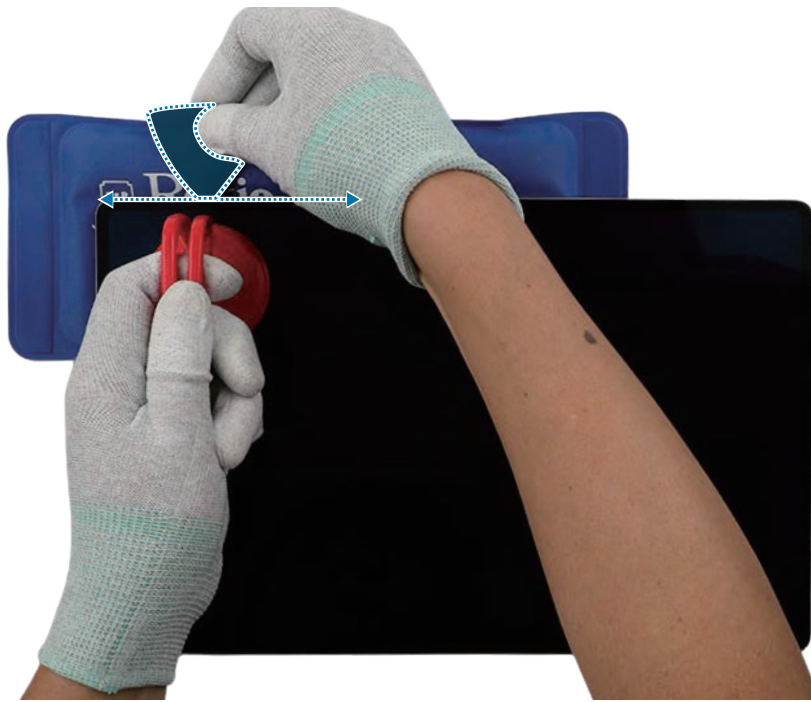



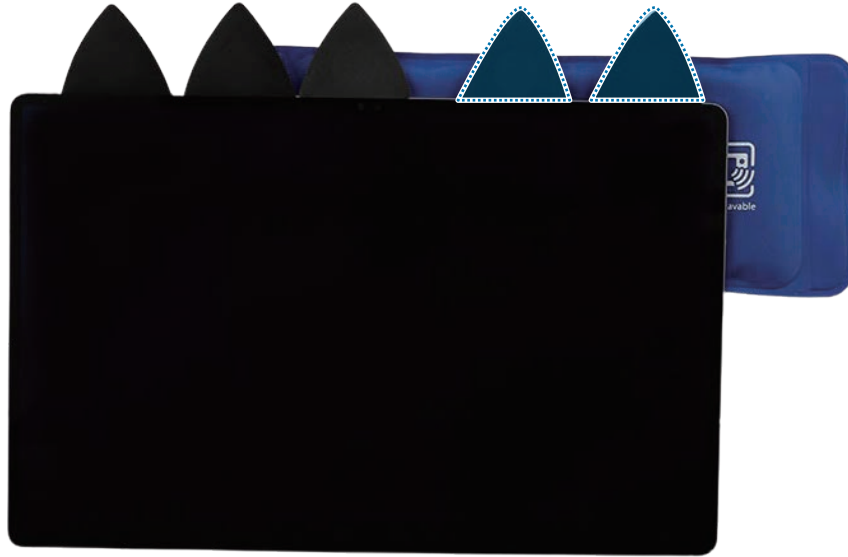

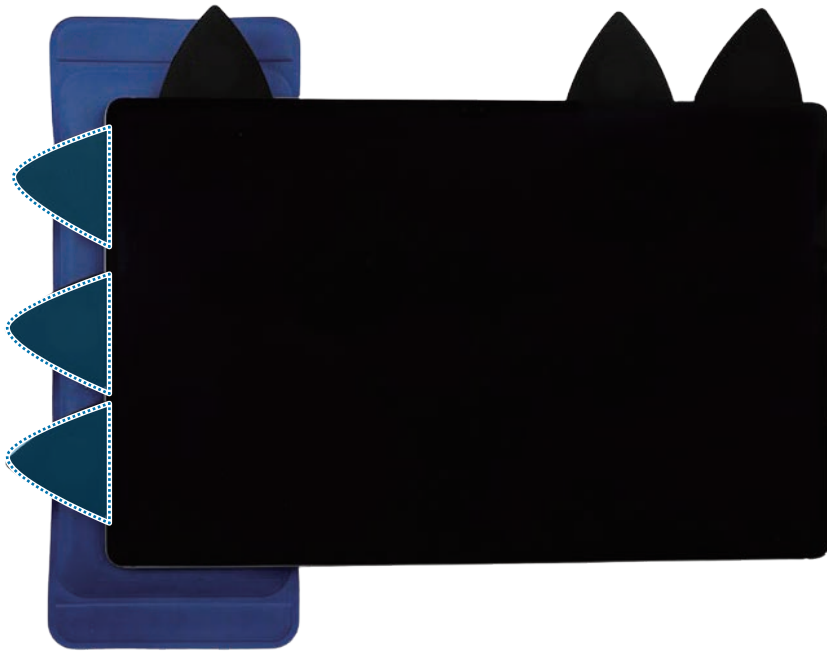
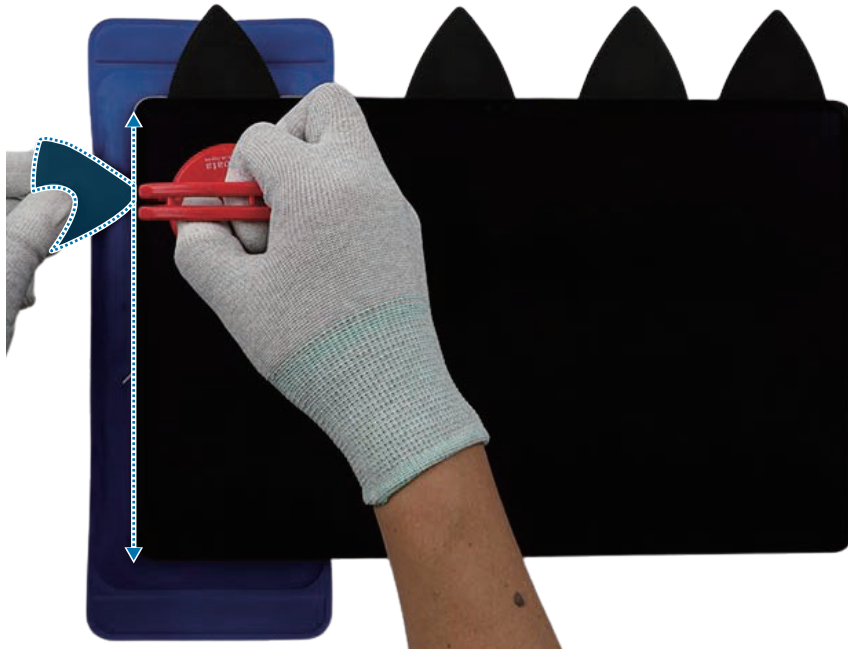



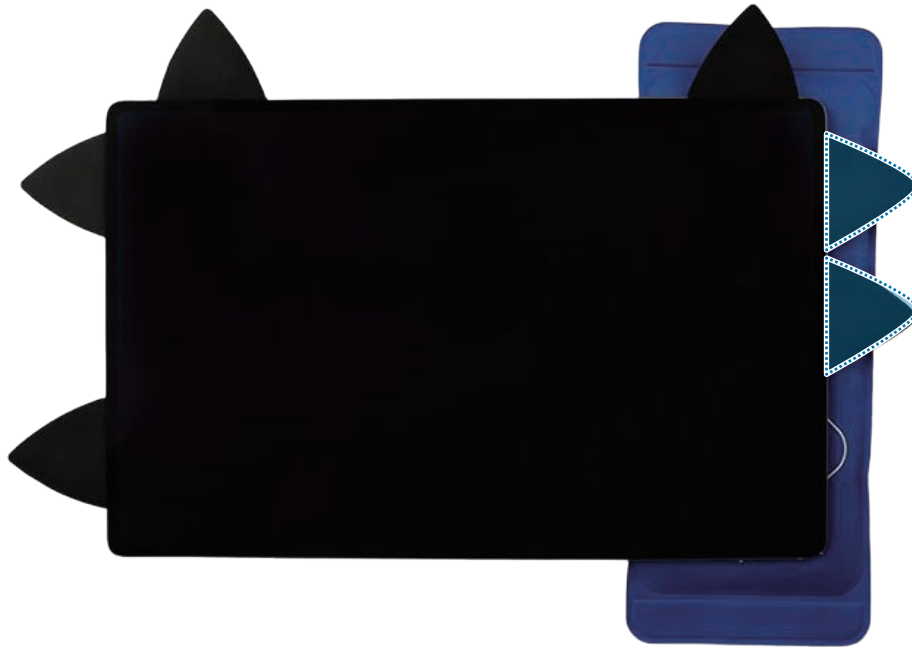

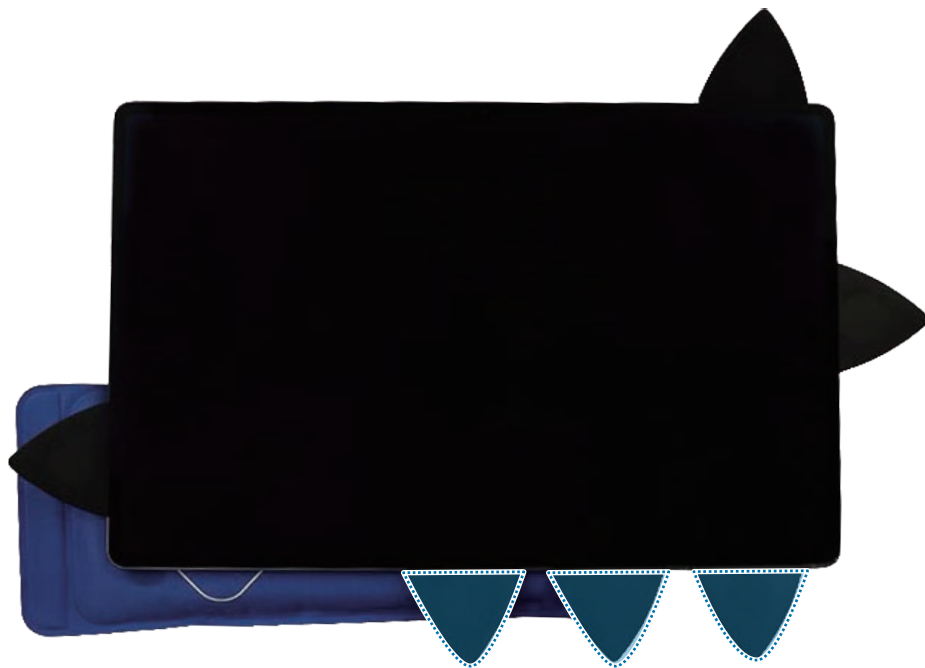
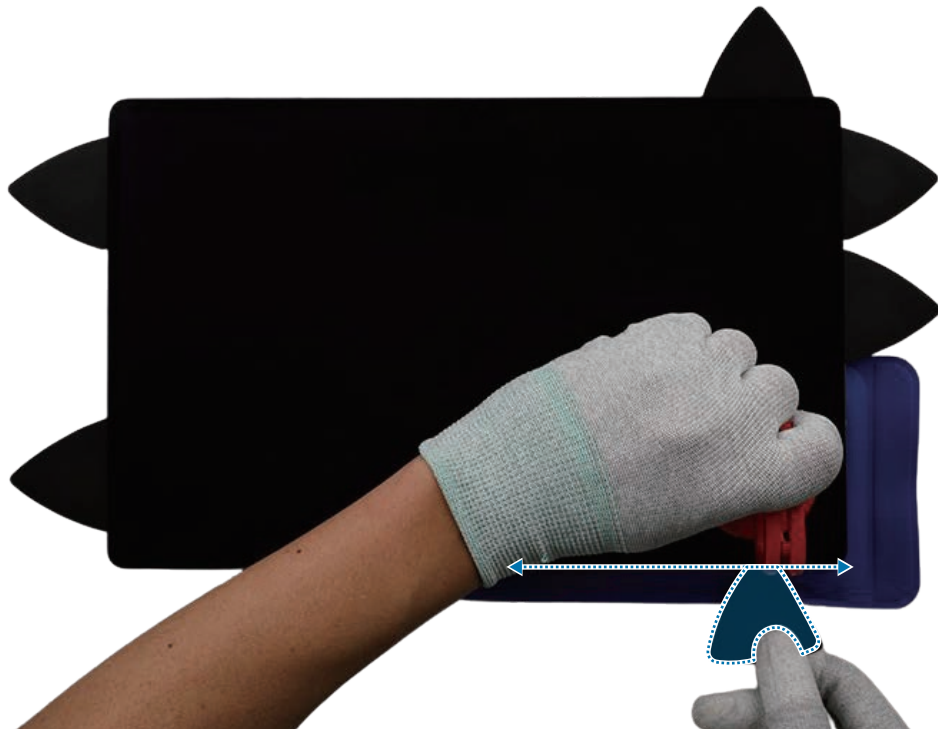

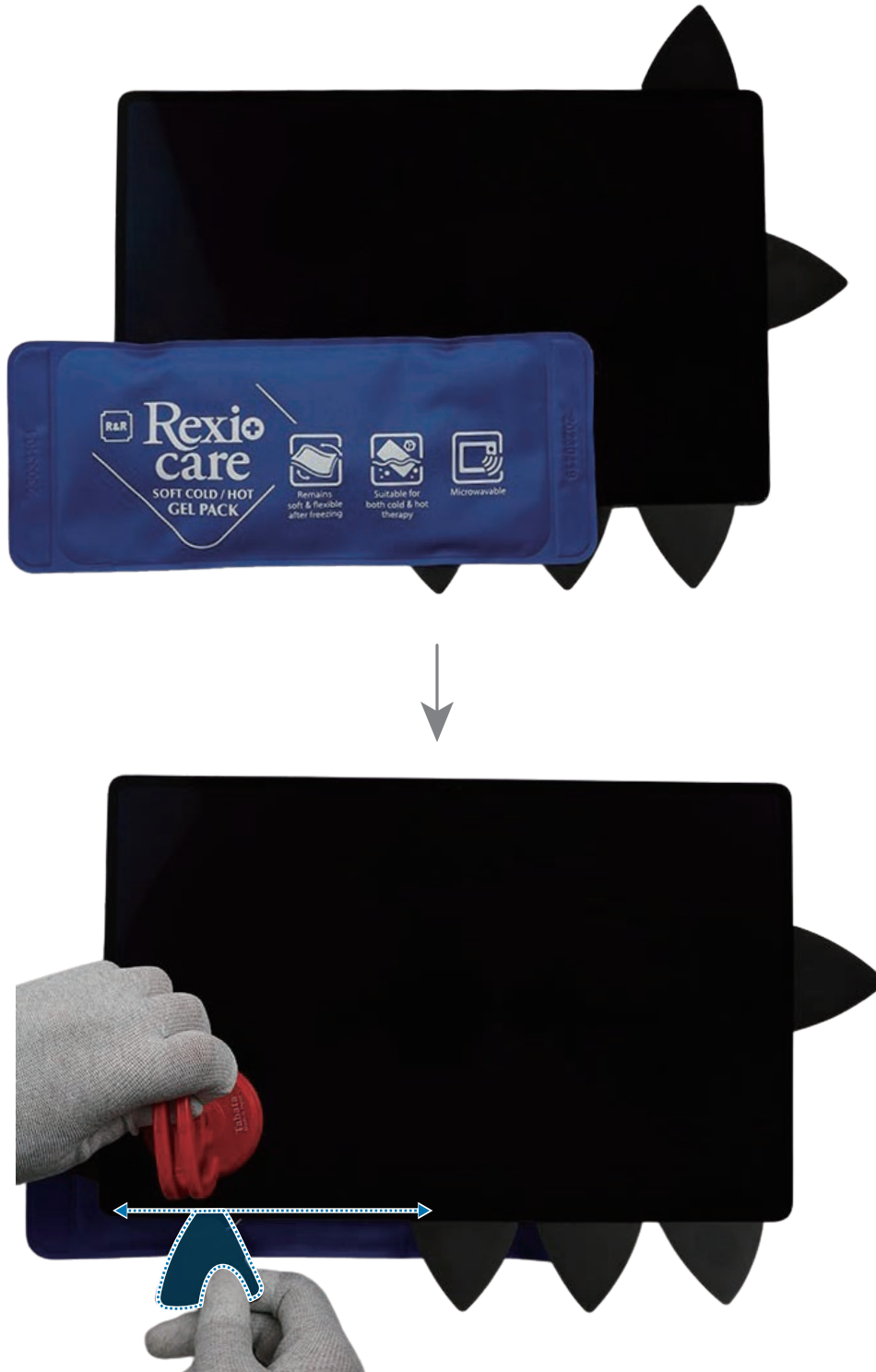

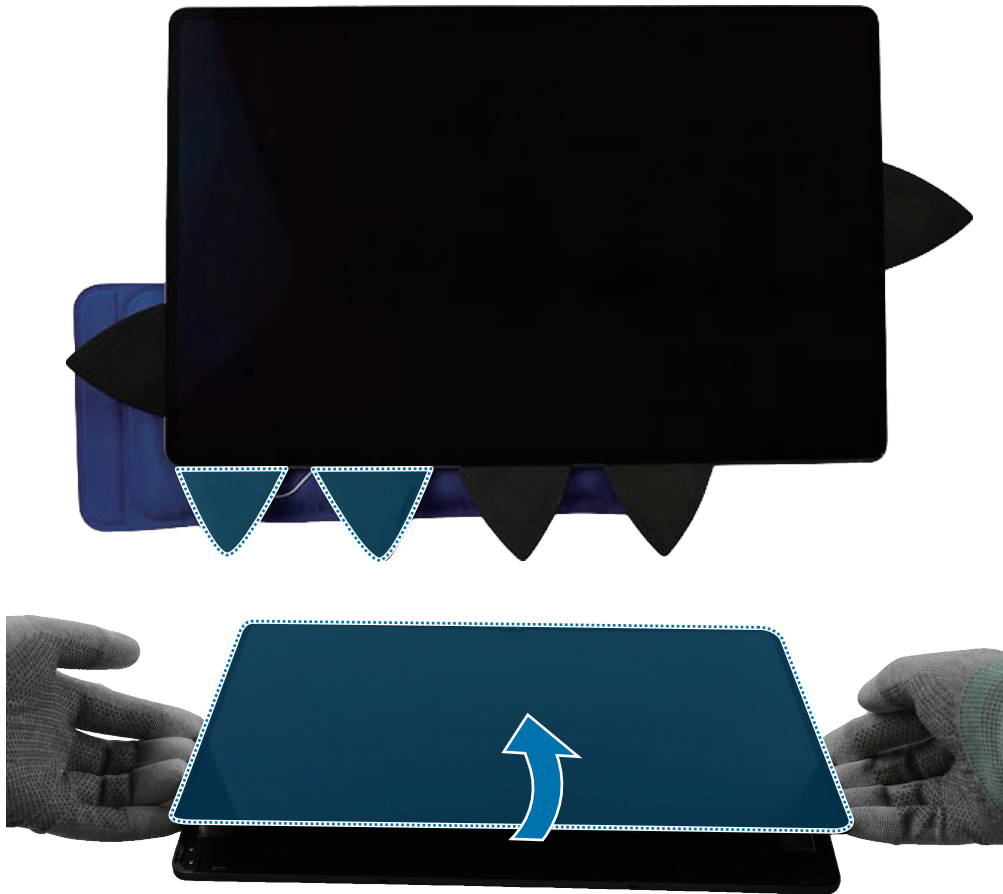





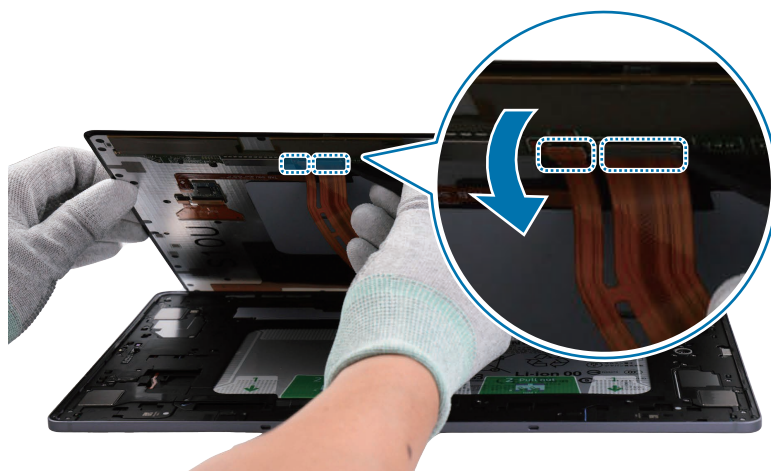

4 Before removing the screen completely, separate the 2 flex cable connectors from the screen with the tweezers. Lift the screen and separate it from the back cover module completely.

- ⚠ • Make sure to separate the connectors before removing the screen completely.
- Be careful not to damage the cables while removing the connectors.



Reassembly

-  Leaving screws inside the device may damage internal components, such as the battery. When assembling, be extra careful not to leave any unassembled screws inside the device.
 -  Before attaching the screen, make absolutely sure that there are no screws, miscellaneous parts, or other foreign objects on the inside of the device (among the battery, PBA, etc.).
 -  The adhesive tape's composition may vary depending on the country, region, or carrier. Check the tape provided and proceed with the appropriate item for each step.
- 1 Using the tweezers, remove all adhesive tapes on the inside of the screen (●) and the back cover module (Adhesive part).
 -  • Make sure to remove any residual tapes (●) attached to the inside of the screen or the back cover module before reassembling the device.
 - Be careful not to damage the near components.
 -  Apply additional heat with a microwaveable heating bag if you are having trouble separating the adhesive.

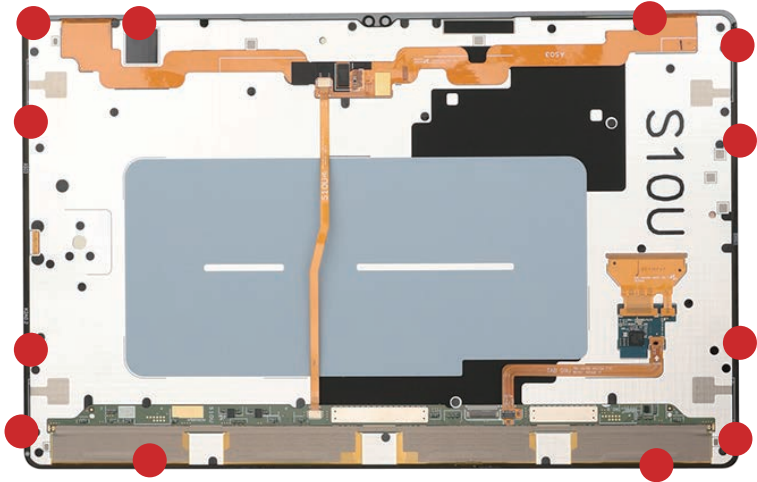

Adhesive part

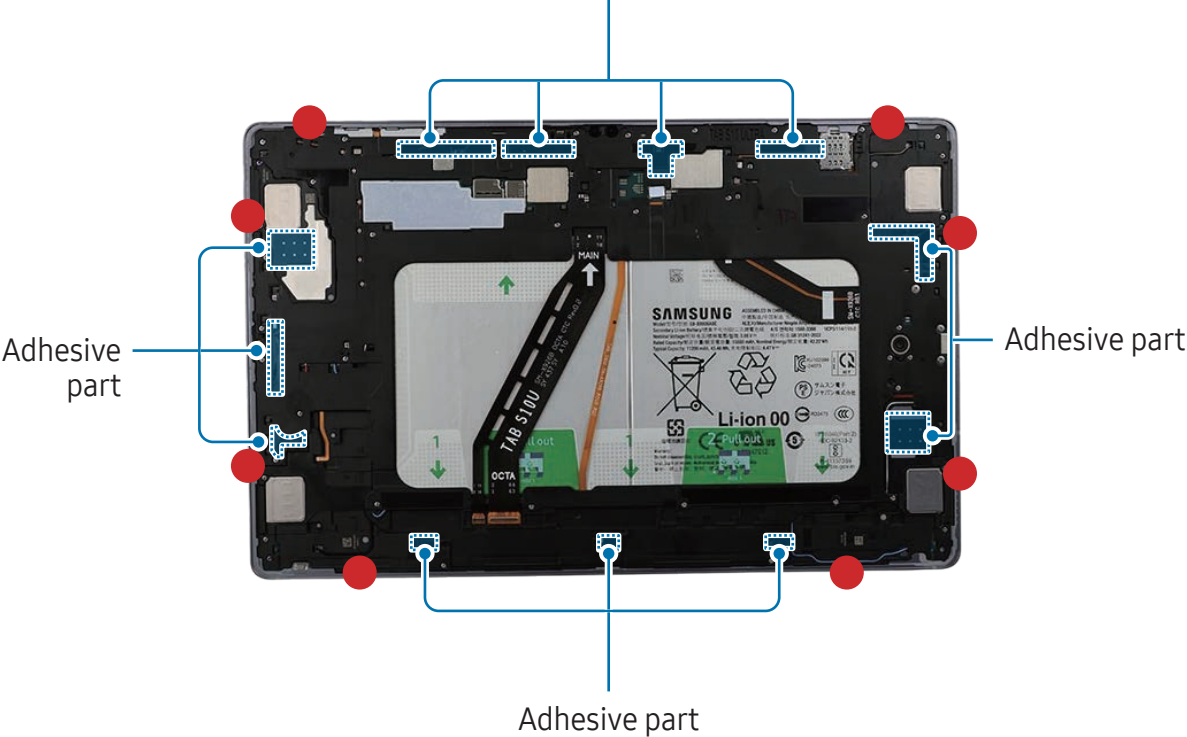

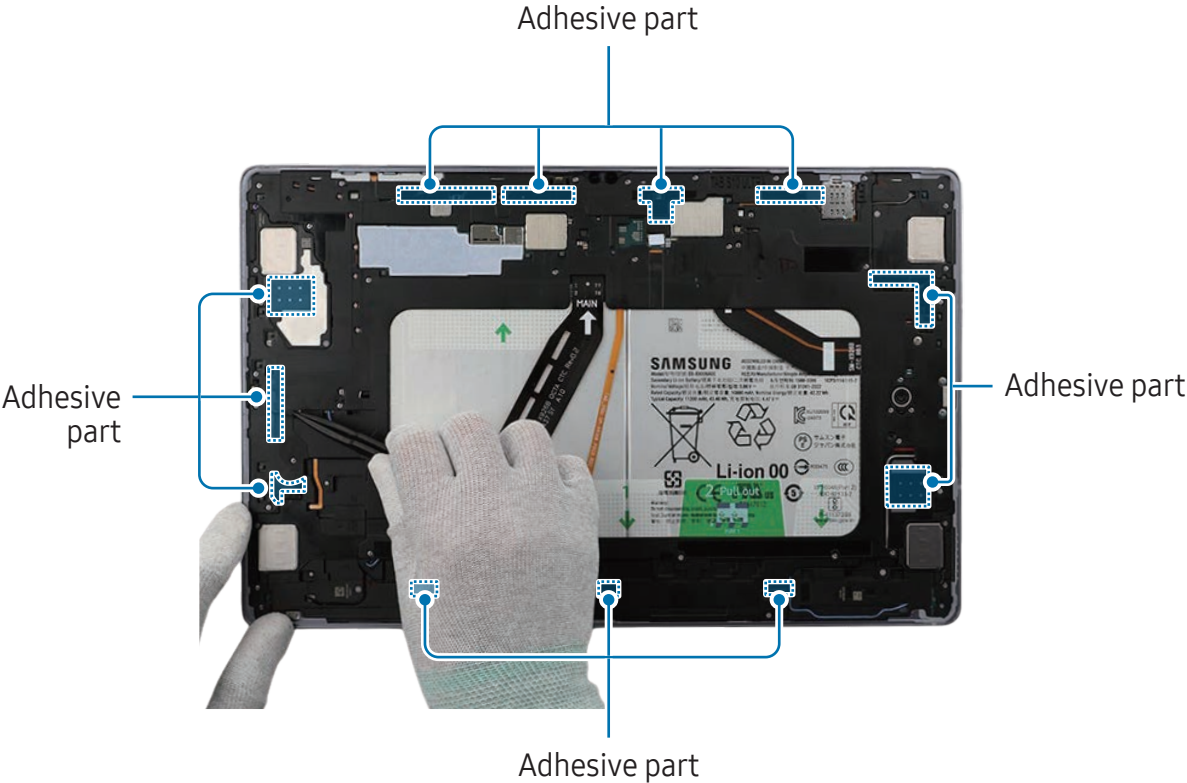
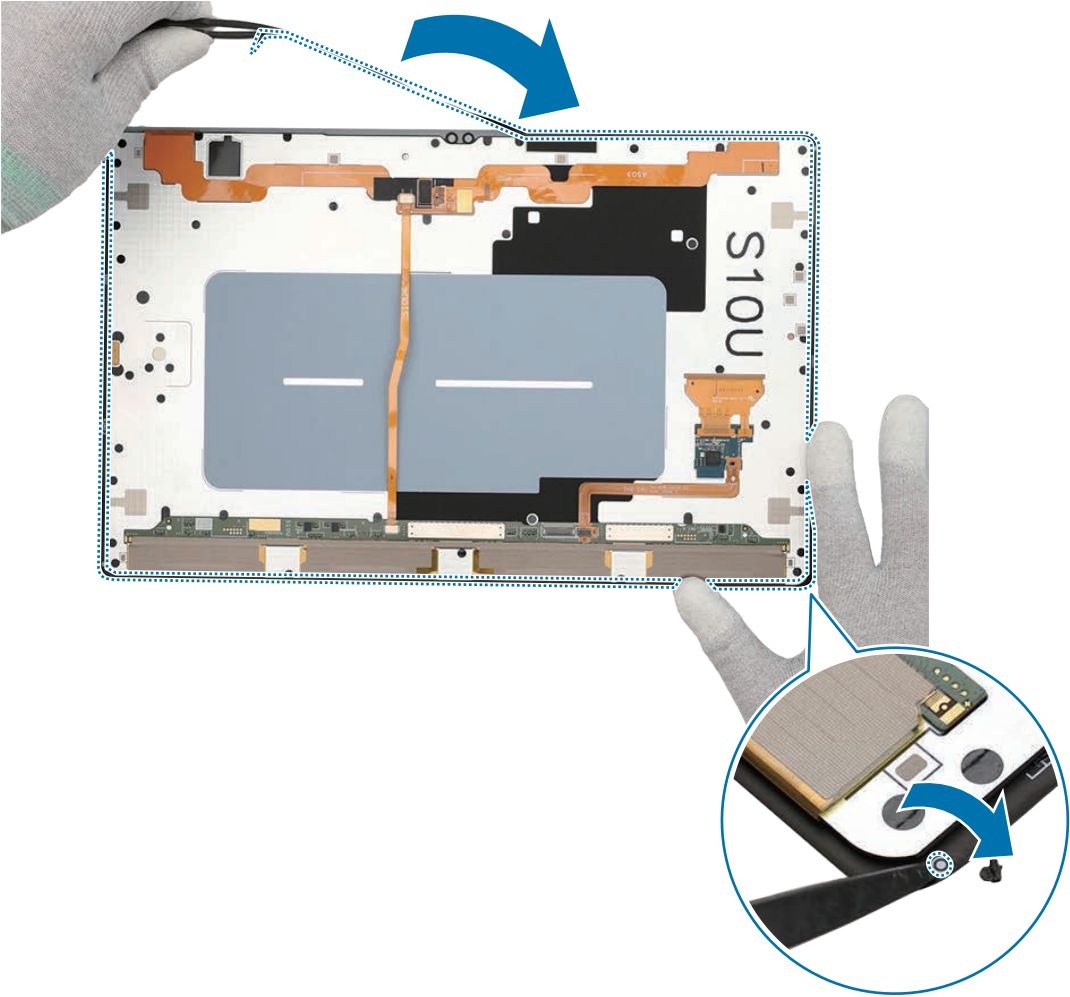

- Using the tweezers, remove the transparent film from the screen left adhesive tape. Align the tape precisely with the form on the left of the back cover module and attach it.

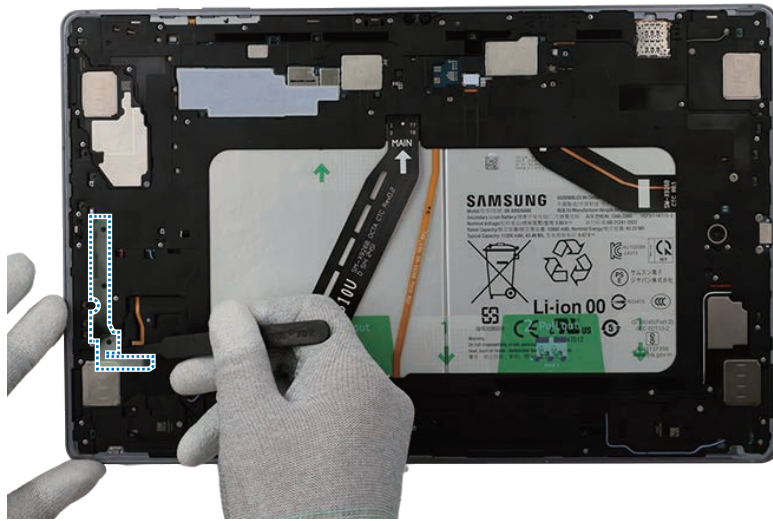

- Using the tweezers or your fingers, gently press down on the tape to ensure a secure fit.

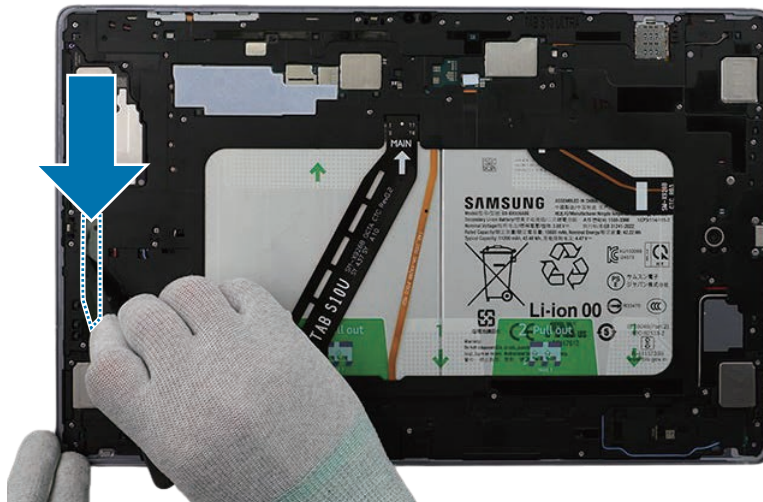

- Using the tweezers, remove the transparent film from the screen bottom adhesive tape. Align the tape precisely with the form on the bottom of the back cover module and attach it.

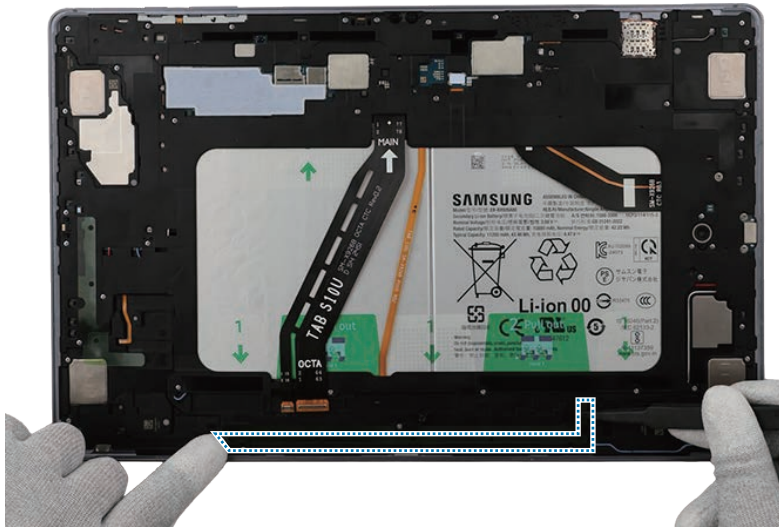

- Using the tweezers or your fingers, gently press down on the tape to ensure a secure fit.

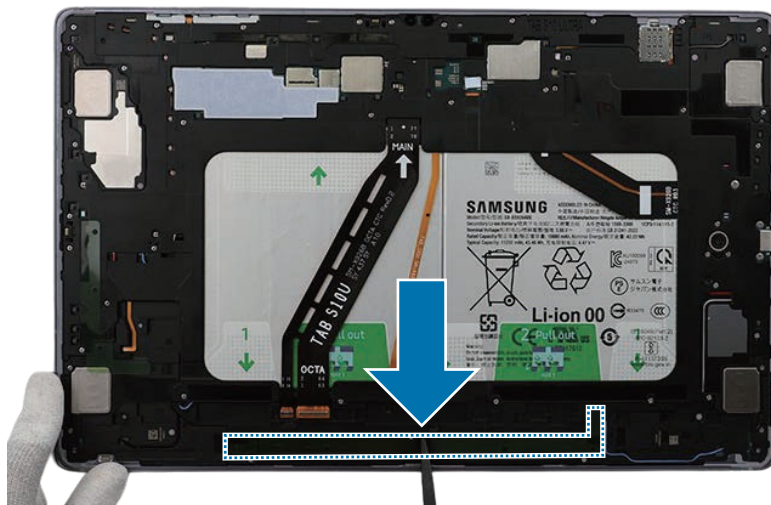

- Using the tweezers, remove the transparent film from the screen right adhesive tape. Align the tape precisely with the form on the right of the back cover module and attach it.

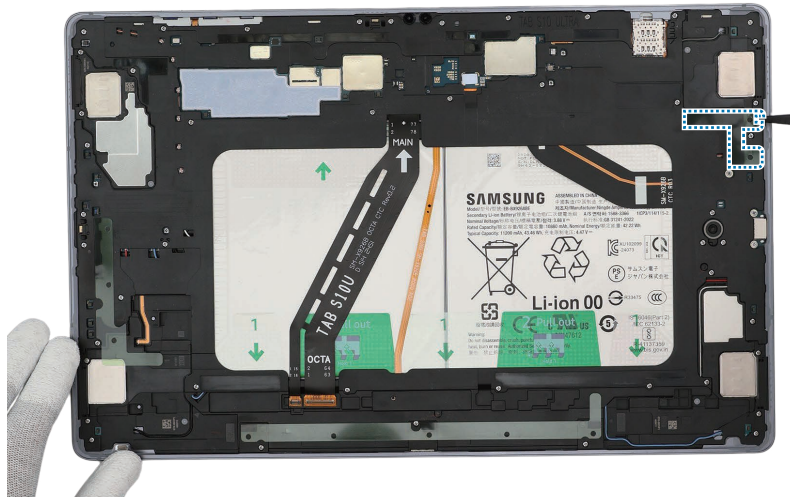

- Using the tweezers or your fingers, gently press down on the tape to ensure a secure fit.

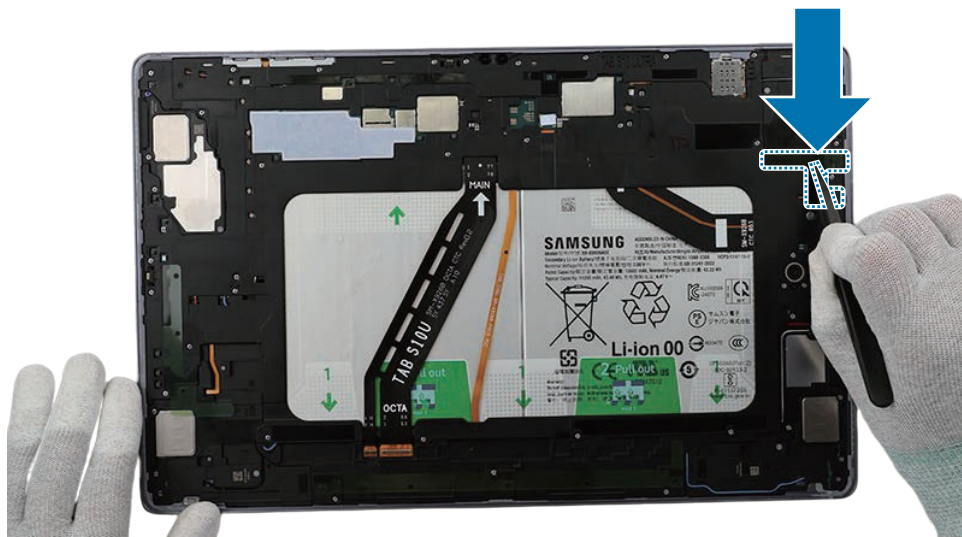

- Using the tweezers, remove the transparent film from the screen speaker adhesive tape. Align the tape precisely with the form on the speaker 2 and attach it.

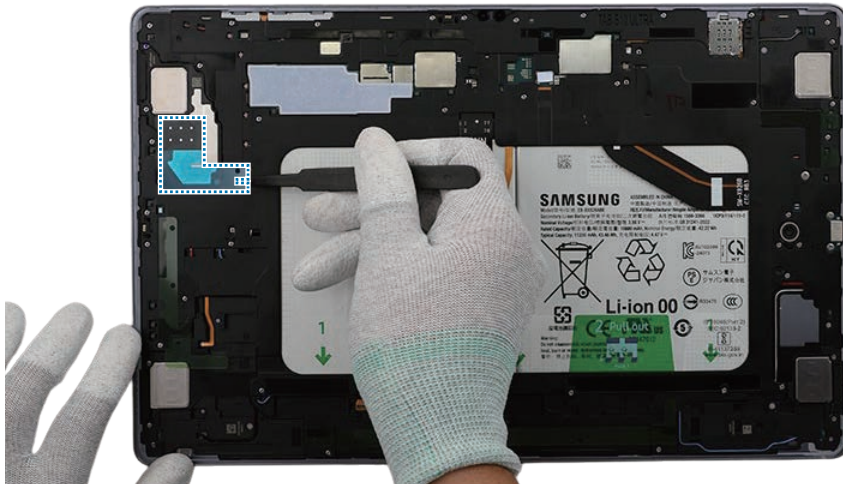

- Using the tweezers or your fingers, gently press down on the tape to ensure a secure fit.

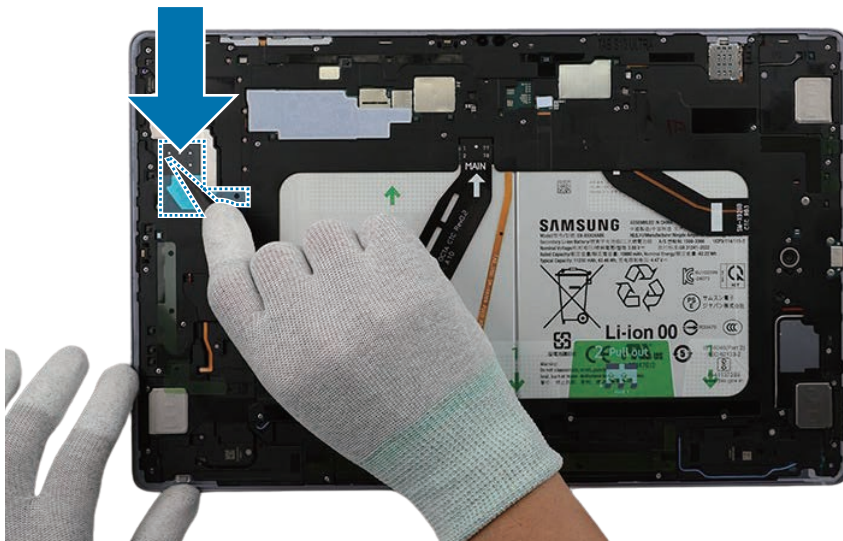

- Using the tweezers, remove the transparent film from the screen speaker adhesive tape. Align the tape precisely with the form on the speaker 4 and attach it.



- Using the tweezers or your fingers, gently press down on the tape to ensure a secure fit.

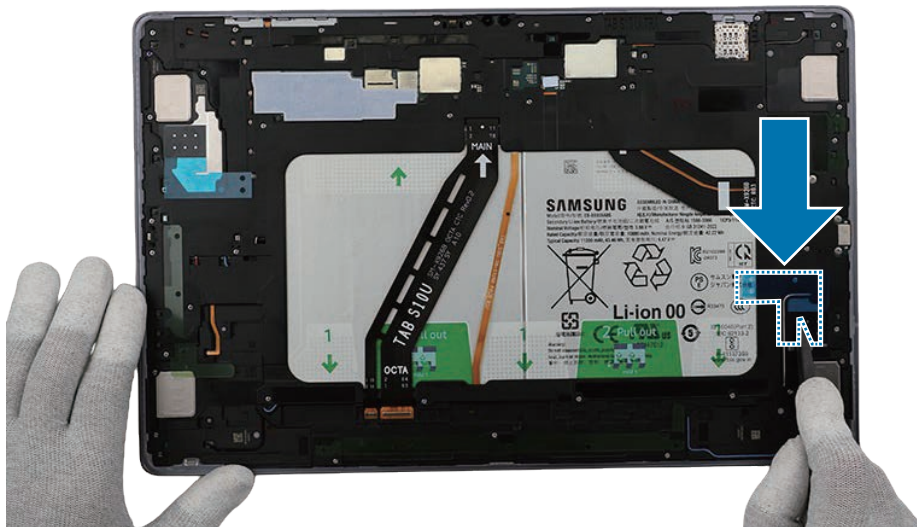

- Using the tweezers, remove the transparent film from the screen top adhesive tape. Align the tape precisely with the form on the top of the back cover module and attach it.

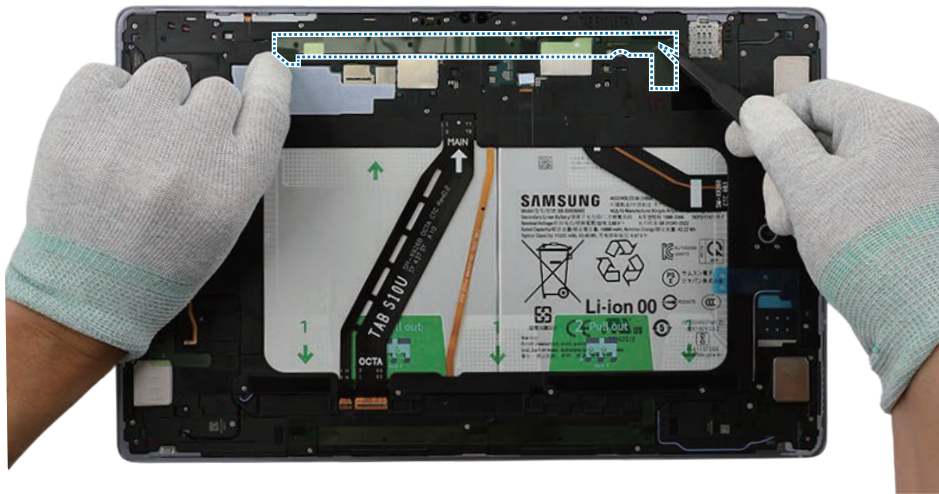

- Using the tweezers or your fingers, gently press down on the tape to ensure a secure fit.

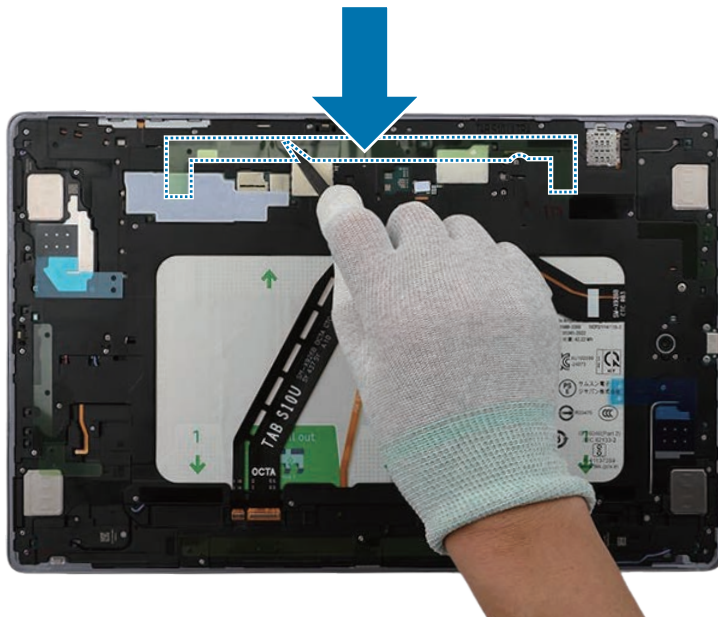

- 14 Using the tweezers, remove the inner vertical transparent film on the centre of the new screen adhesive tape.

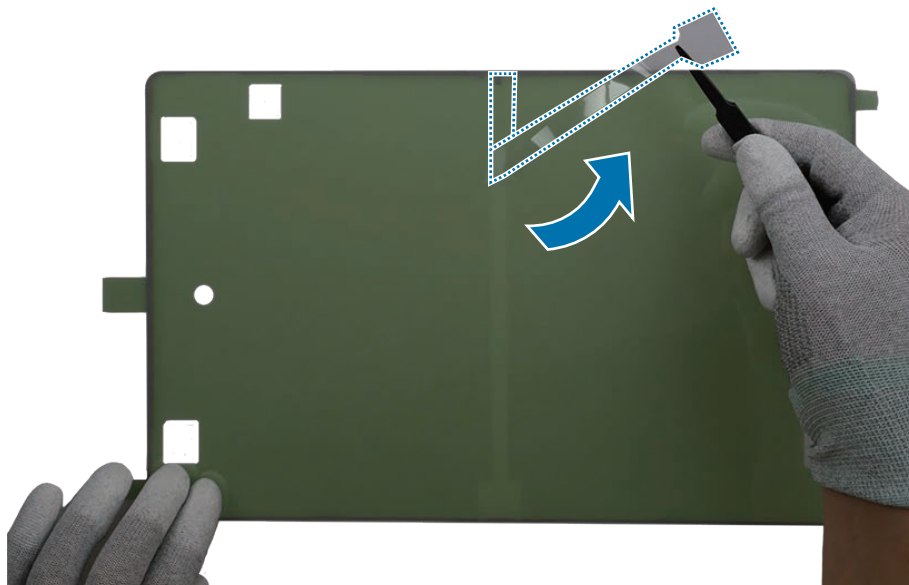

- 15 Using your fingers, align the adhesive tape precisely on the back cover module and attach it. Using the tweezers and your fingers, gently press down the upper and lower middle of the adhesive tape to ensure a secure fit.

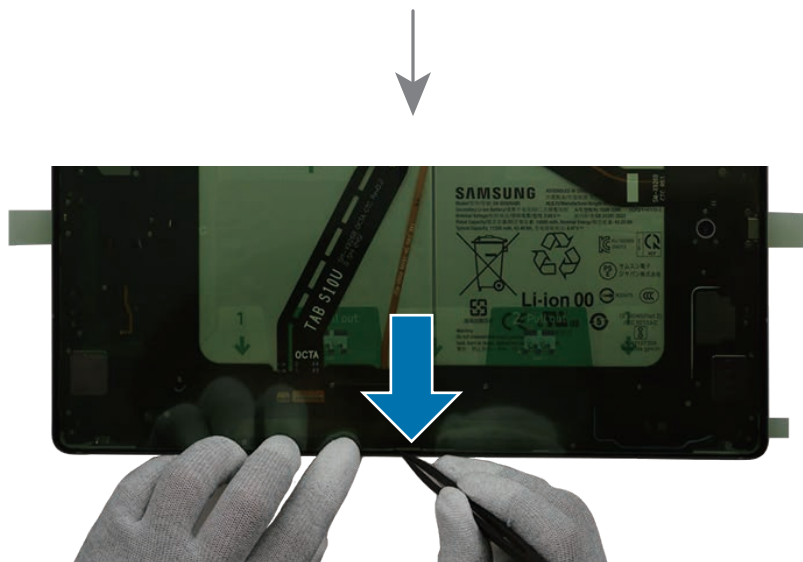
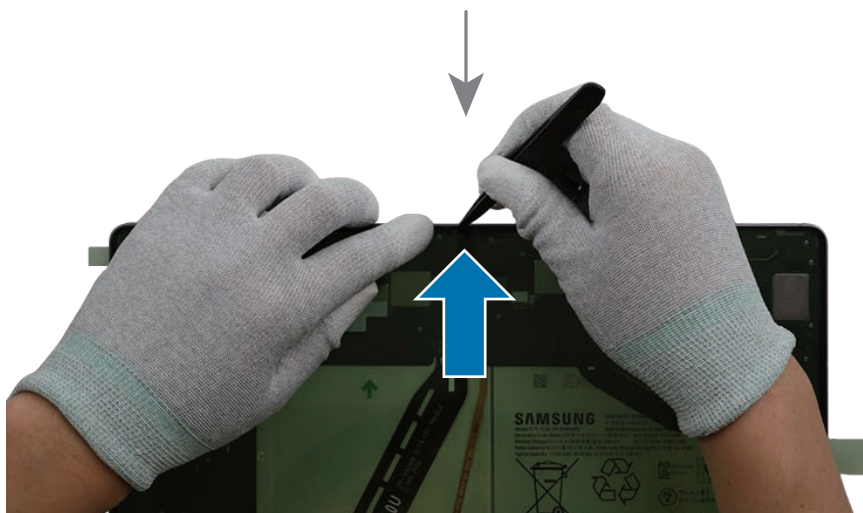
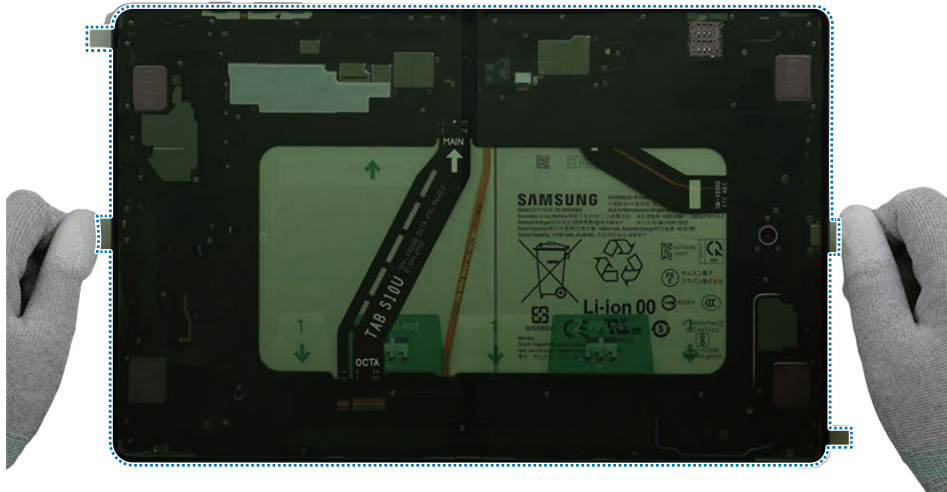

- 16 Using your fingers, lift the right side of the adhesive tape and remove the inner transparent film from the centre of the inside.



- 17 Using your fingers, lift the left side of the adhesive tape and remove the inner transparent film from the centre of the inside.



- 18 Using the tweezers, align the adhesive tape precisely on the back cover module and attach it. Using the tweezers and your fingers, gently press down on the edges to ensure a secure fit.



- 19 While holding the handle of the release film, remove the green transparent film from the adhesive tape.



20 Using the tweezers or your fingers, remove all remaining release films on the back cover module.

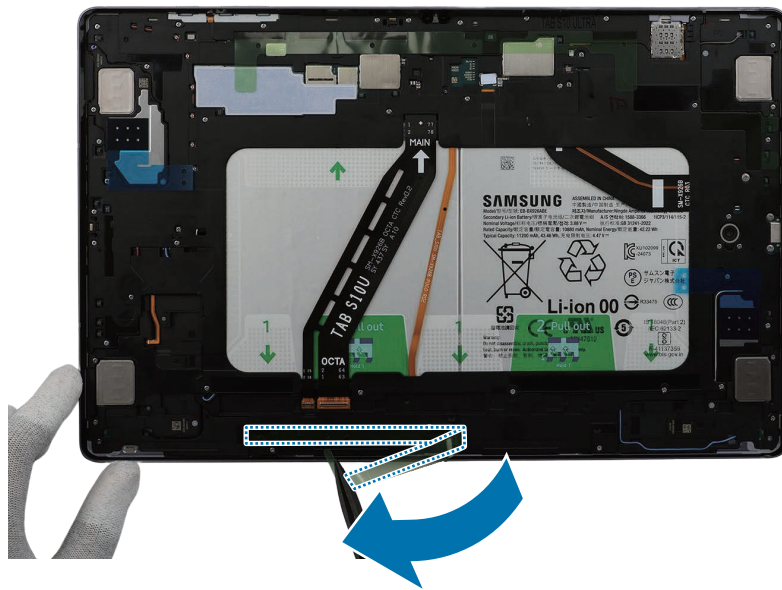
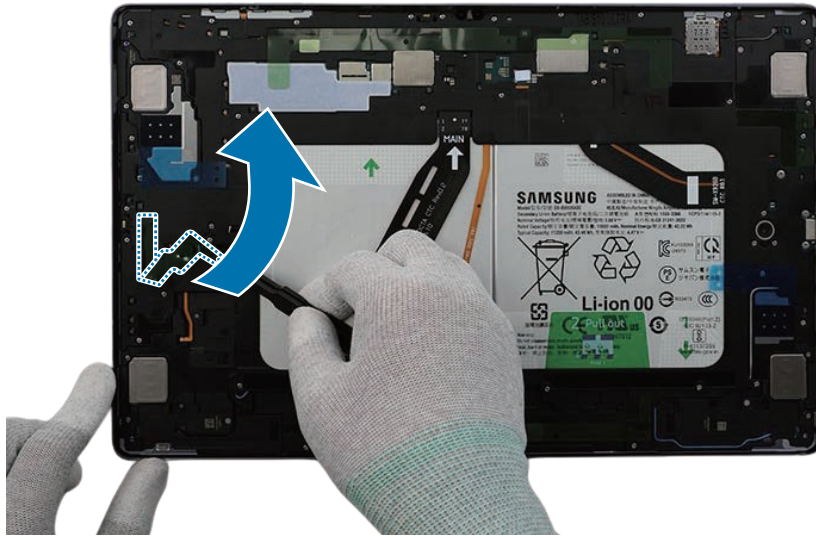

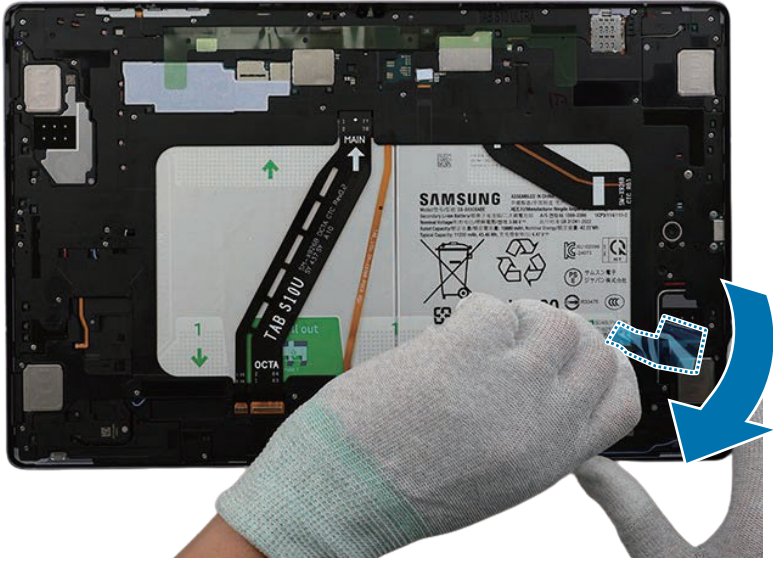
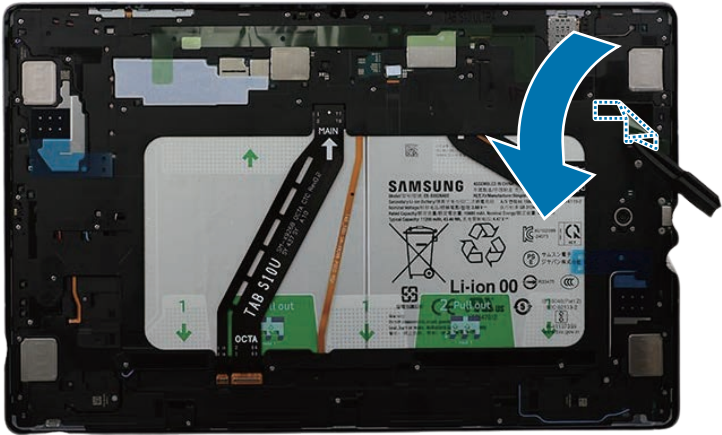

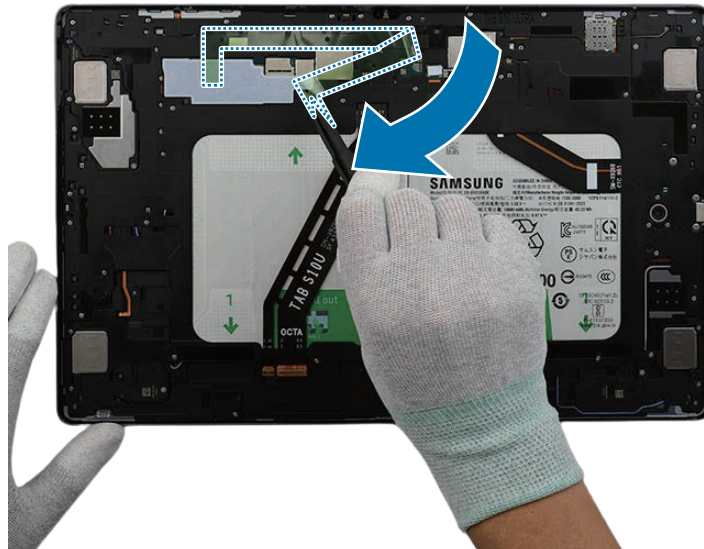

21 Leave the inside of the screen visible and connect the 2 flex cable connectors between the screen and the back cover module using your fingers.

- ⚠ • Be careful not to damage the cables and the connectors.
- Be careful not to damage the screen.

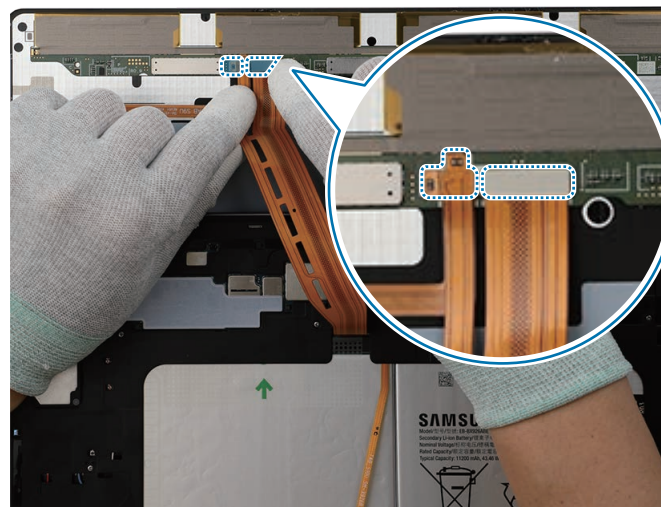

22 Turn the screen slowly over back to its original state and attach it to the back cover module.

- ⚠ Be careful not to damage the cables and the connectors.
- Be careful not to damage the screen.

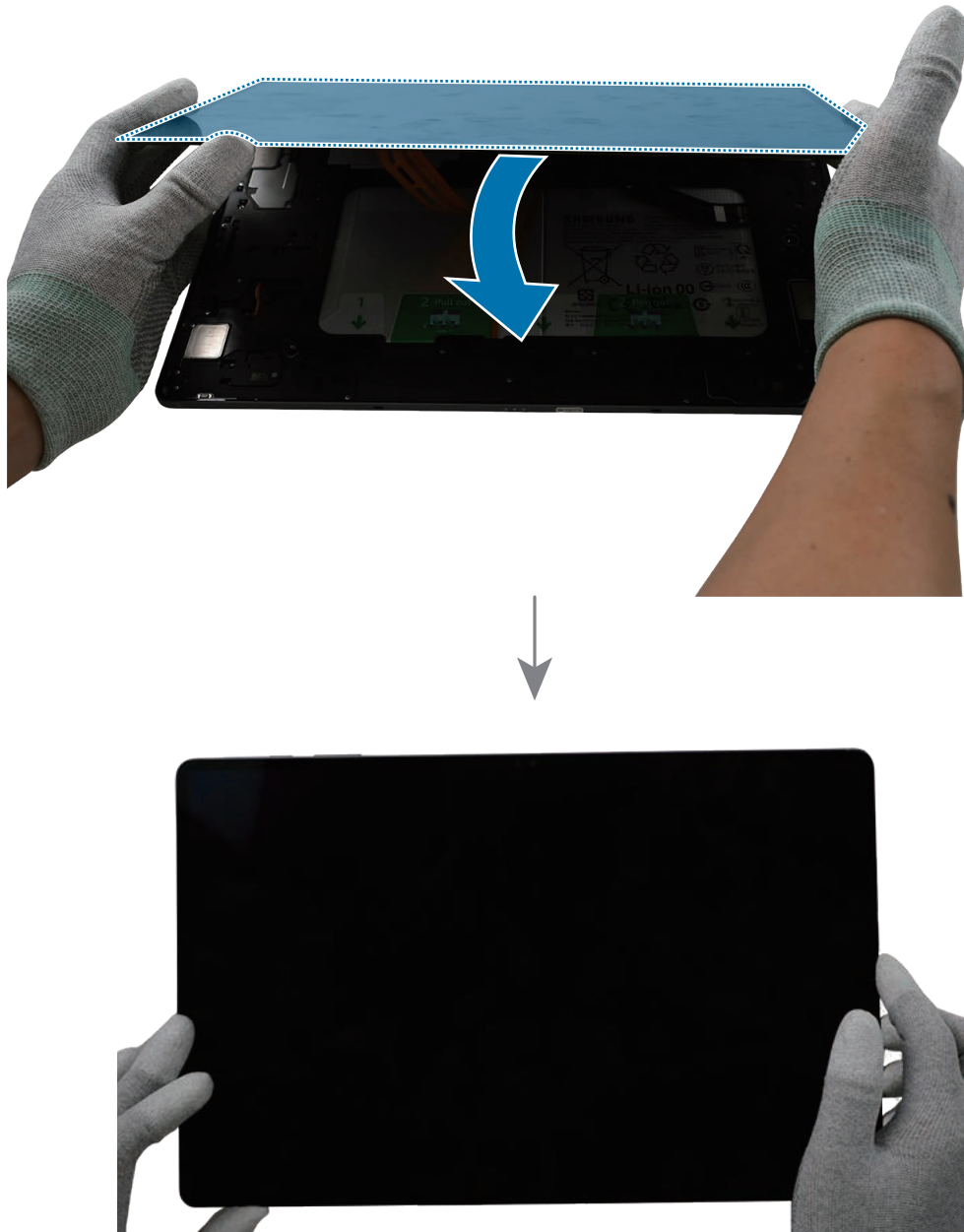

23 Press down on the edges of the screen evenly in order to attach the screen perfectly.

 If you feel some gap, remove the screen and attach it again. Some foreign materials can be inside the device.

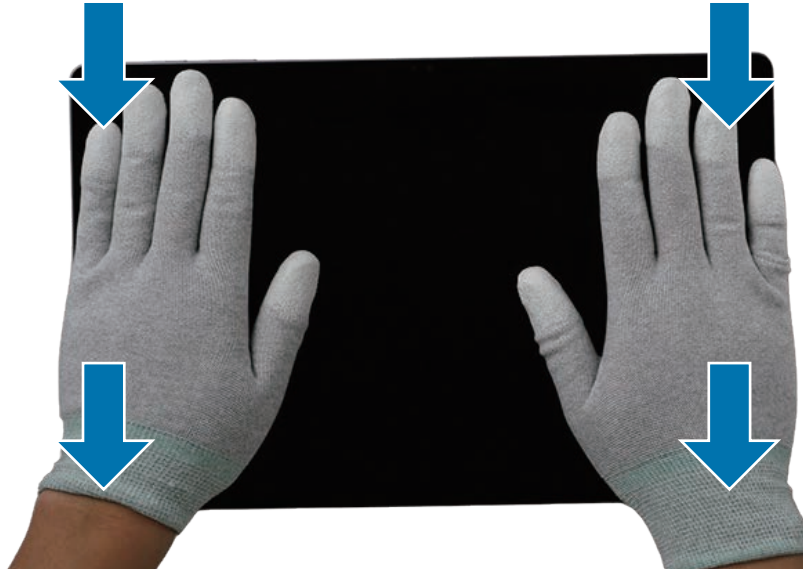

24 Now you can press the fully assembled screen using the press fixture. Remove the press fixture body and its handle from the rental tool kit packaging.

 Keep your hands out of the press fixture to avoid mechanical pinching and injury.

- 
- This tool is only available to use by the rental of tool kit that contains a complete set of the tools for self repair service.
 - Availability of rental service may vary depending on the country and is currently available only in limited countries.
 - A rented tool kit packaging may have different packaging than shown.

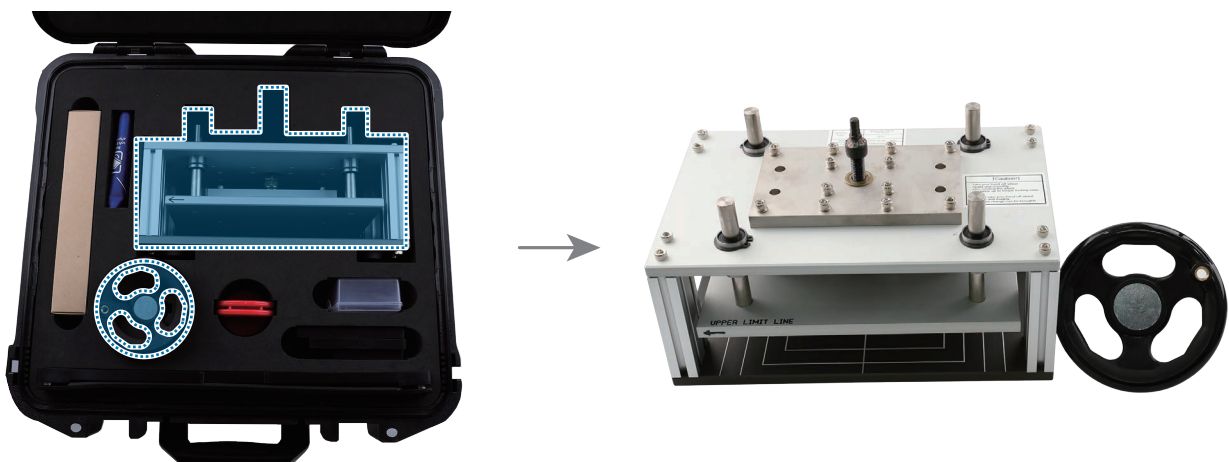

25 Carefully position the torque limit handle horizontally at the top of the press fixture.

 Keep your hands out of the press fixture to avoid mechanical pinching and injury.

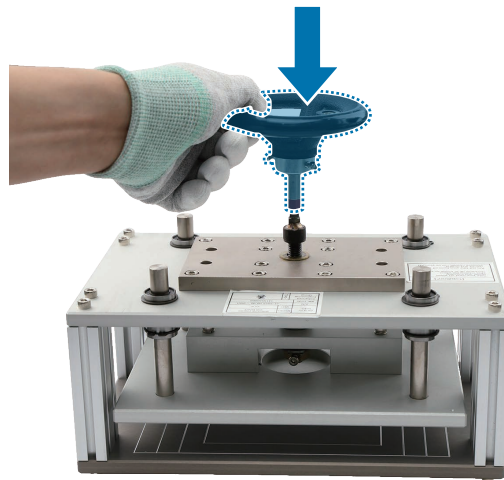

26 Remove the bottom press tray and top press tray from the rental tool kit packaging.

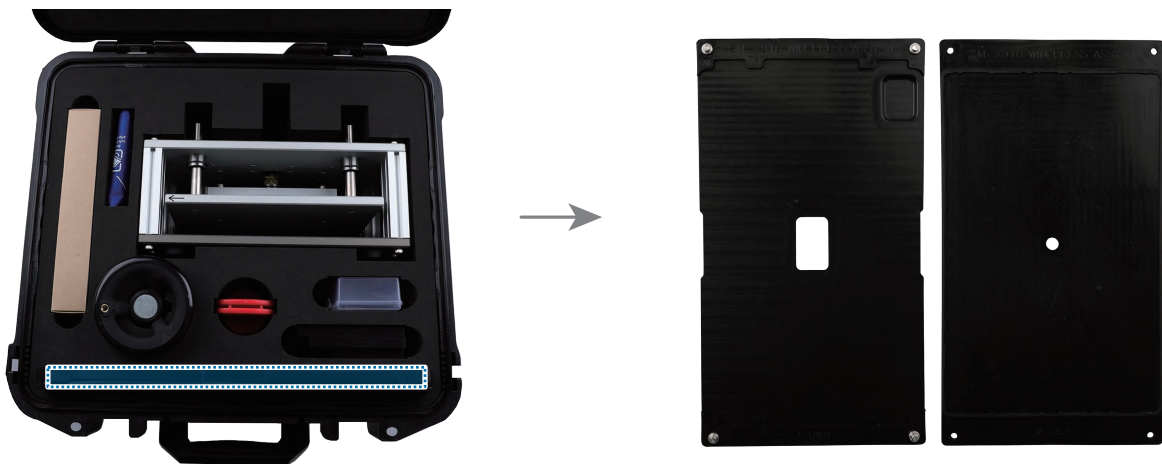

27 Place the screen facing up, and then place the device on the bottom press tray position.

 The model names on the press tray may vary.

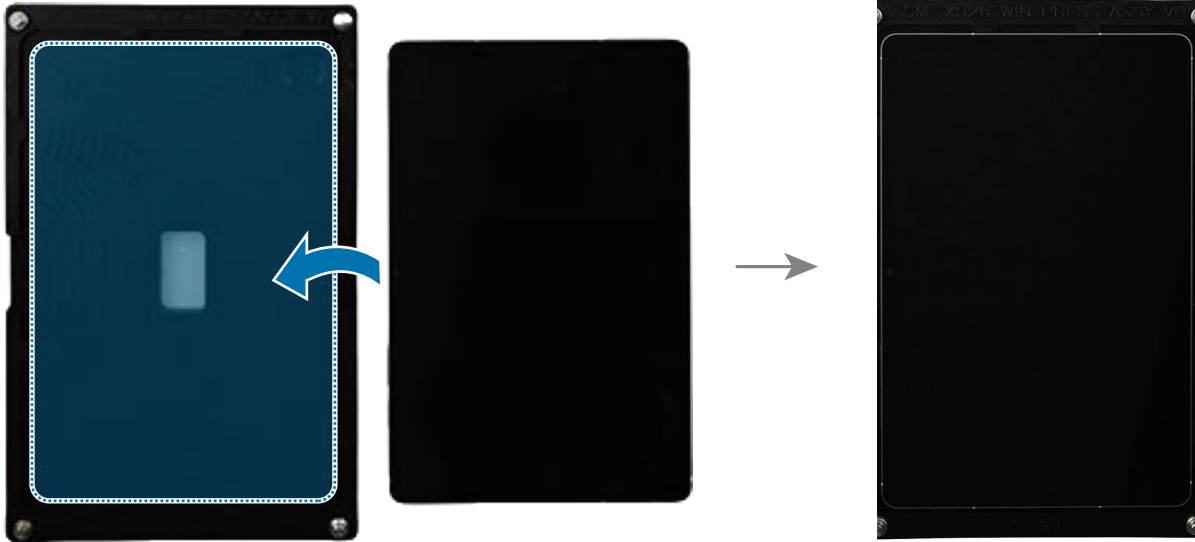

28 Place the top press tray in the position of the bottom press tray and lightly press it to assemble so that each corner can be fixed to the guide pin.

 Be careful not to damage the screen and device.

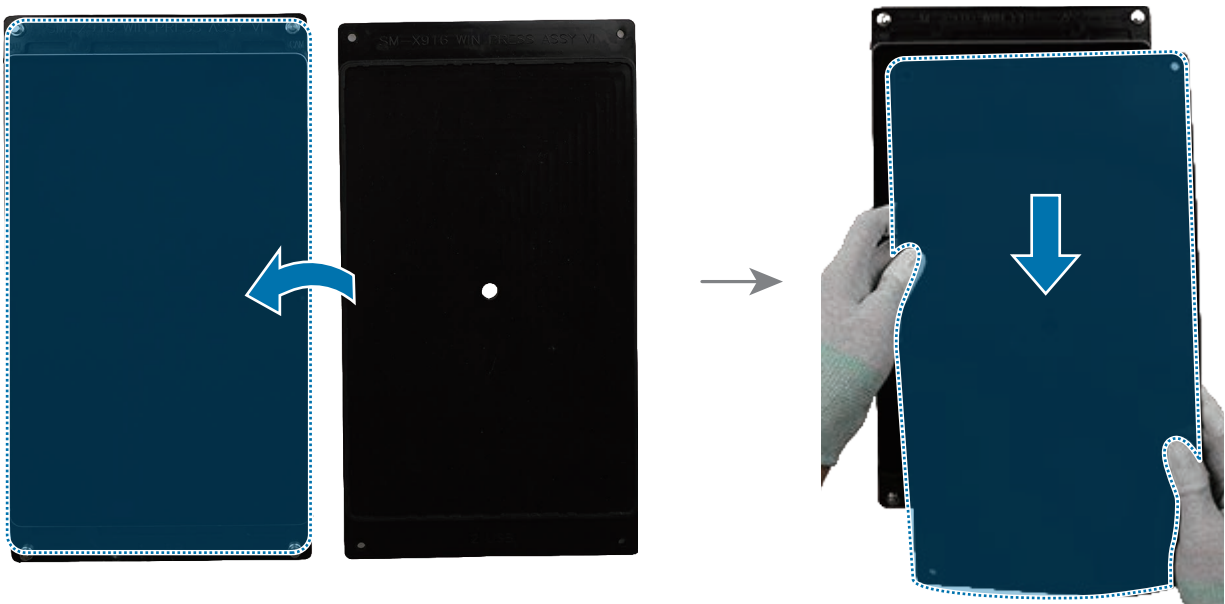



29 Position the top half of the press tray with the device lengthwise in the centre of the press fixture.

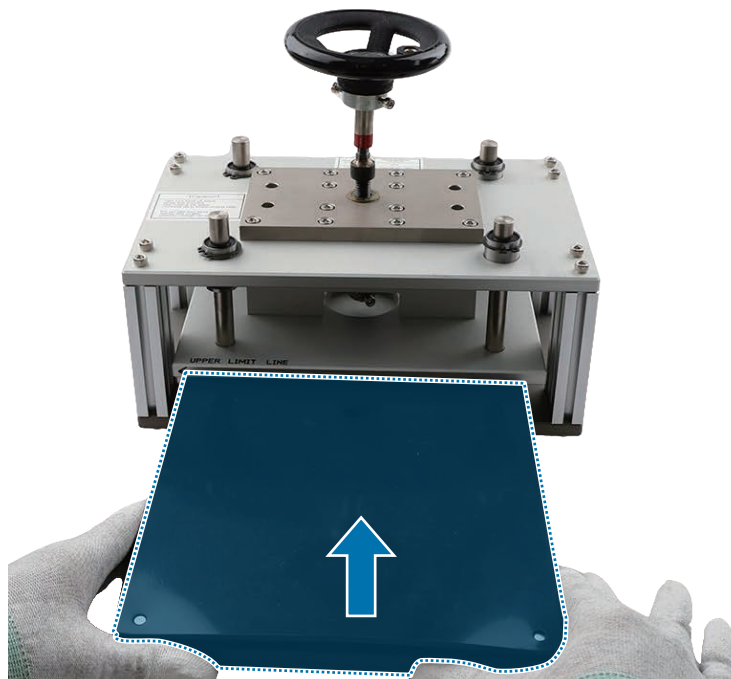

30 Rotate the torque limit handle to the clockwise until it makes a sound. In that press state, stay the tray for 30 seconds.

 Keep your hands out of the press fixture to avoid mechanical pinching and injury.

 When you reach the required maximum force (1 N), a sound is made from the handle if you turn the handle.

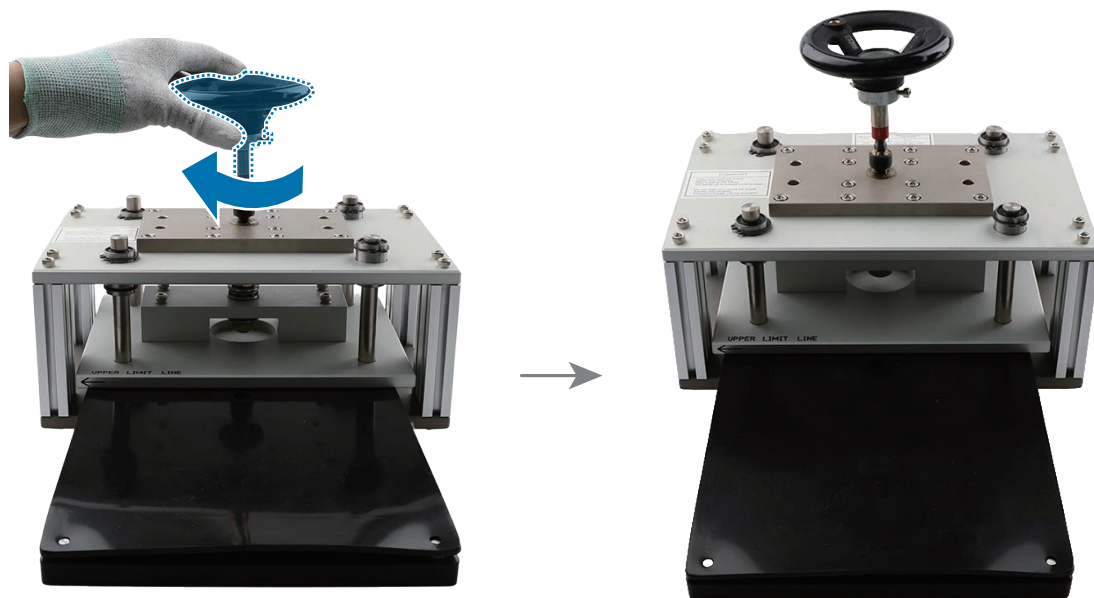

31 When the press is completed after 30 seconds, rotate the torque limit handle to the anticlockwise and remove the tray from the press fixture.

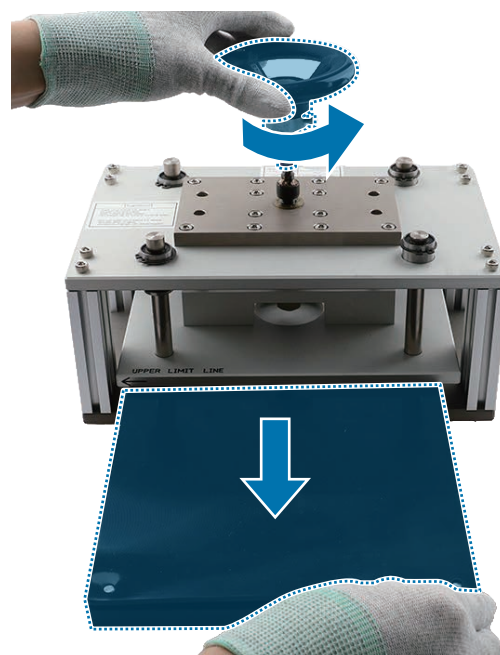

- 32 Position the bottom half of the press tray with the device lengthwise in the centre of the press fixture.

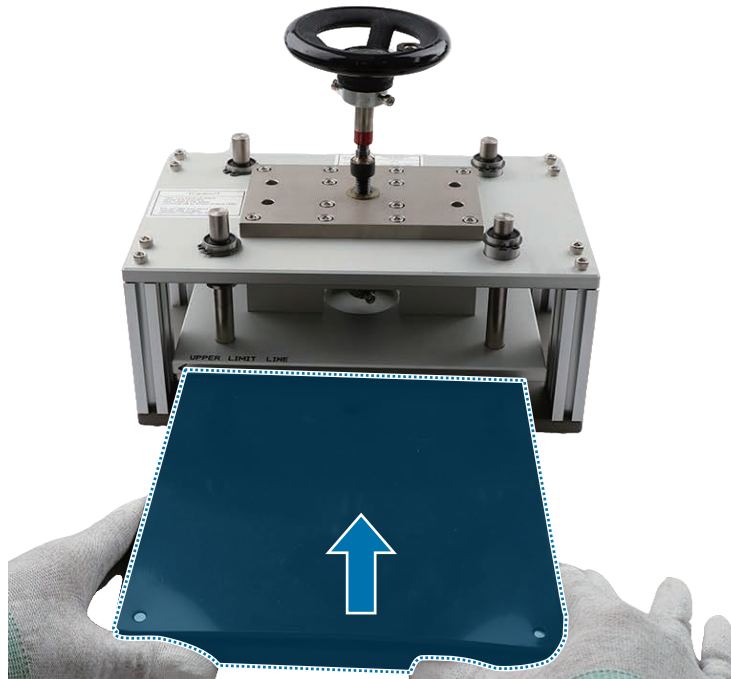

- 33 Rotate the torque limit handle to the clockwise until it makes a sound. In that press state, stay the tray again for 30 seconds.

- ⚠ Keep your hands out the of press fixture to avoid mechanical pinching and injury.
- ✓ When you reach the required maximum force (1 N), a sound is made from the handle if you turn the handle.

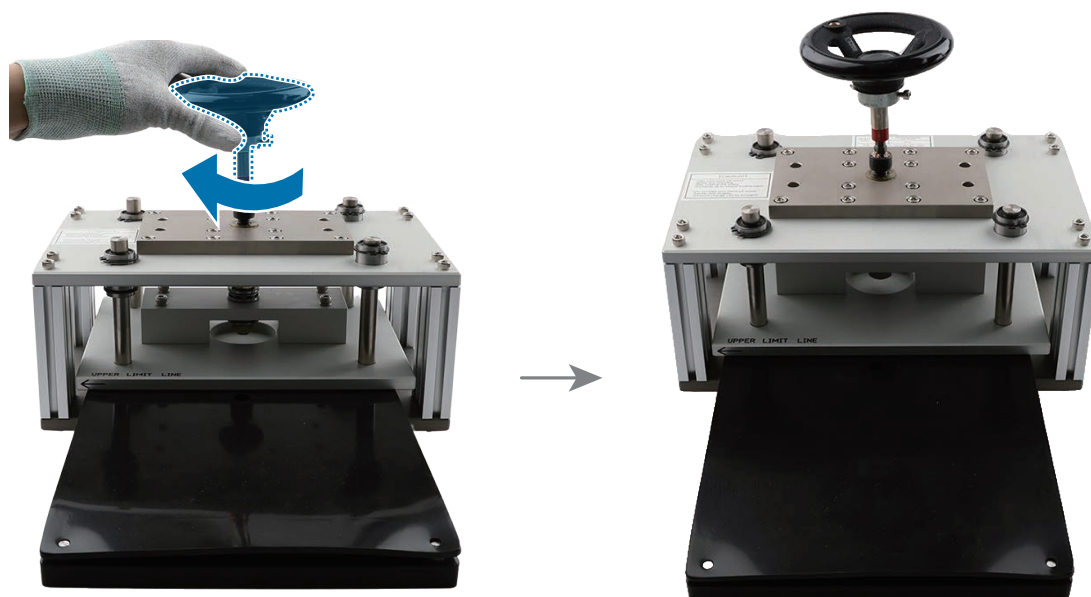

- 34 When the second press is completed after 30 seconds, rotate the torque limit handle to the anticlockwise and remove the tray from the press fixture.

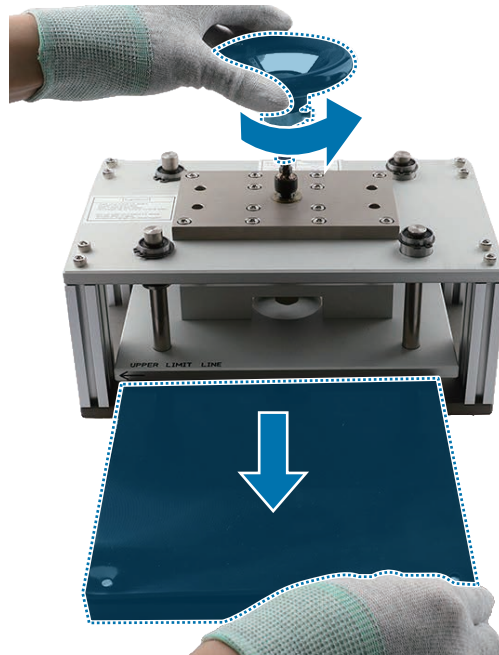

- 35 Remove the device carefully from the tray.

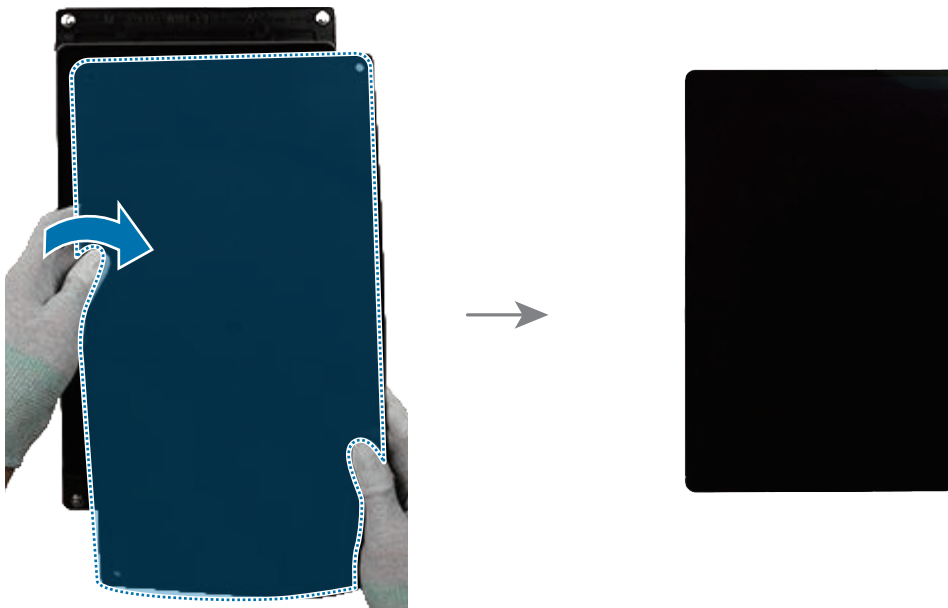



Bracket

Disassembly

 Remove the [Screen](#) first before you begin.

1 Check and remove the screws at the 35 different points on the bracket using a cross-head screwdriver.

 Be careful not to damage the near components.

 Check the number of screws that have been removed, and store them carefully to make sure that no unassembled screws are left inside the device during assembly.

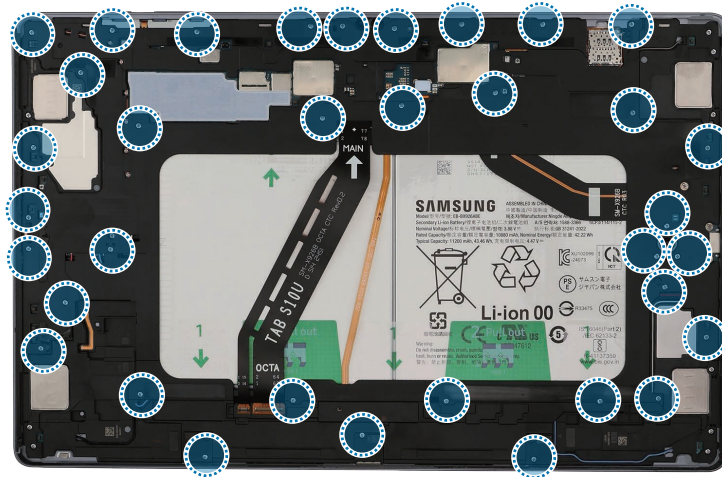

2 Using your fingers, remove the bracket from the back cover module.

 Be careful not to damage the cables and near components.

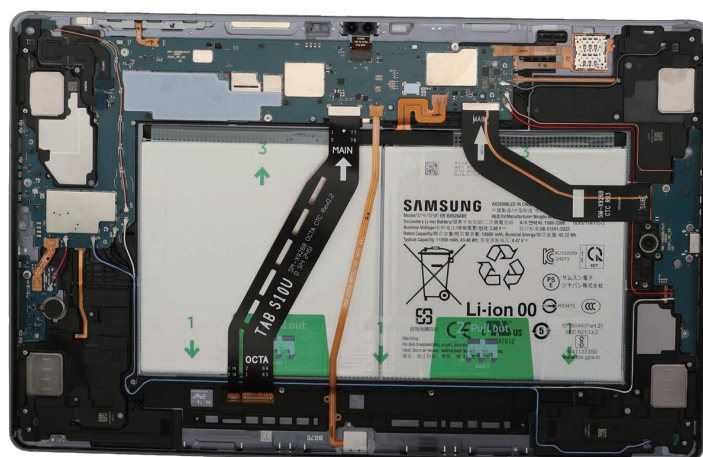
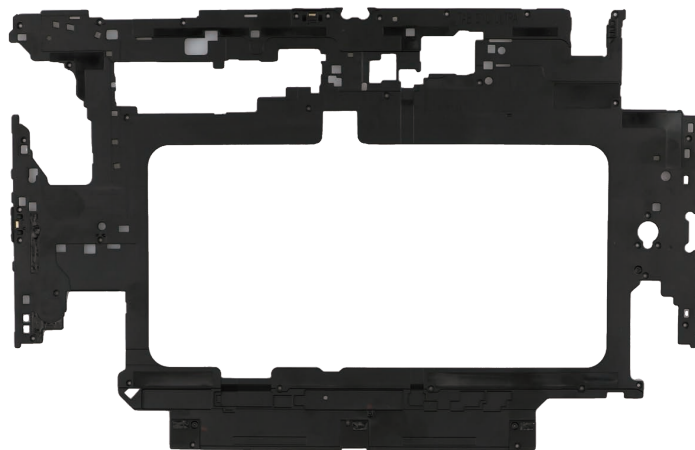

Reassembly

⚠ Leaving screws inside the device may damage internal components, such as the battery. When assembling, be extra careful not to leave any unassembled screws inside the device.

1 Using your fingers, assemble the bracket to the back cover module.

- ⚠** • Be careful not to break the bracket as it is very thin.
- Be careful not to damage the cables and near components.

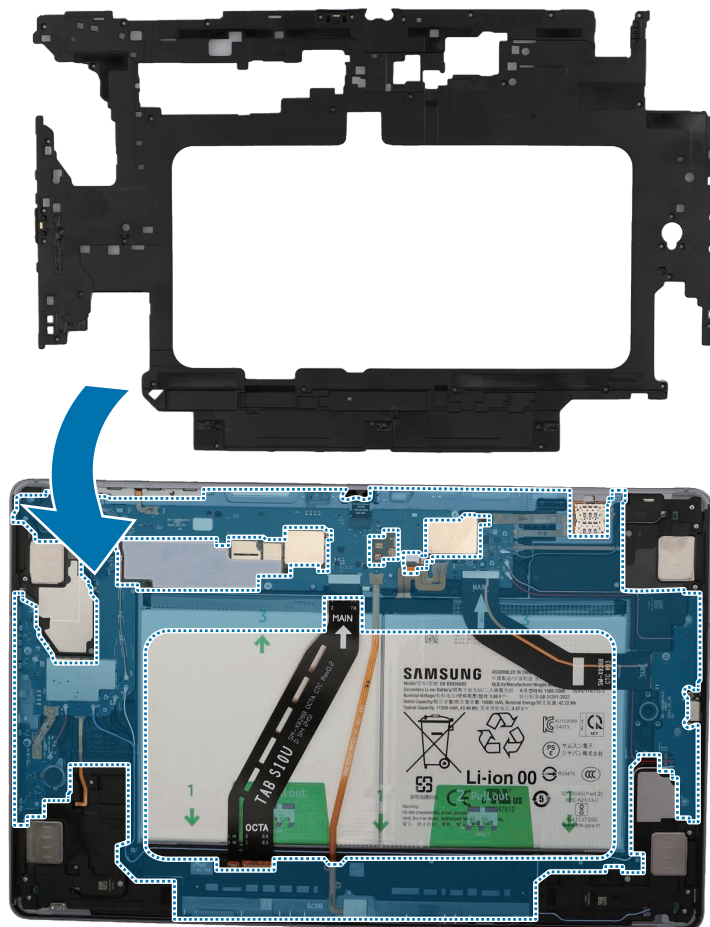

- 2 Check the screw 3405 (35 ea) and fasten them on the bracket using a cross-head screwdriver.

 Be careful not to damage the near components.

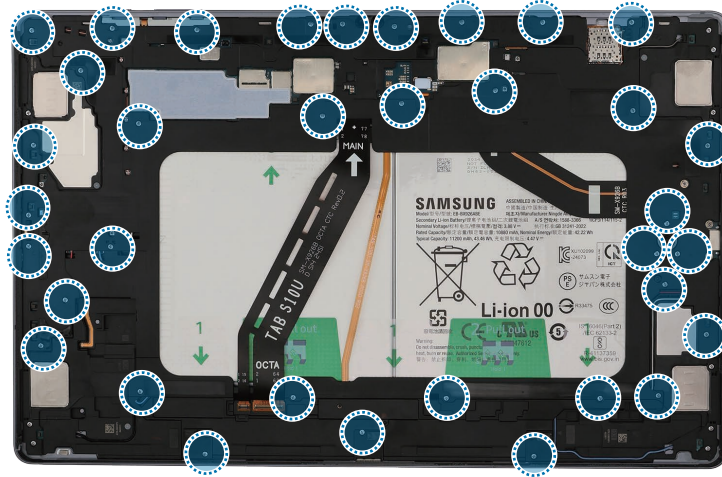

- 3 Check carefully with your fingers to see if there are any screws or other foreign substances inside the device (battery, PBA, cable, etc.). Shake the device lightly with the back of the device facing down to remove any remaining screws.

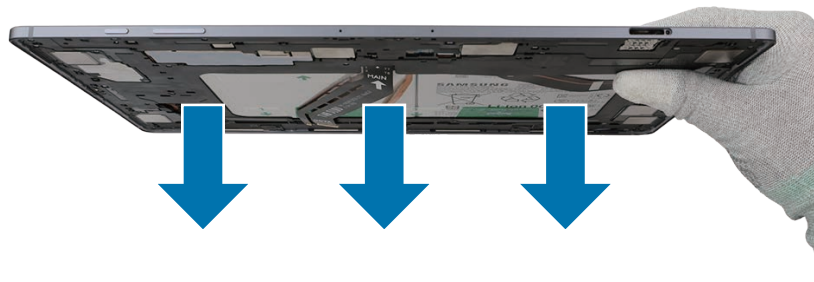

 Reassemble the **Screen** to complete assembly.

Microphone

Disassembly

- Remove the [Screen](#) and [Bracket](#) first before you begin.
- The microphones are already built in the bracket module. Disassemble the microphones only if the microphones themselves require the repairs.

Using the tweezers, disconnect the top microphone and the side microphone from the bracket.

-  Be careful not to damage the bracket.

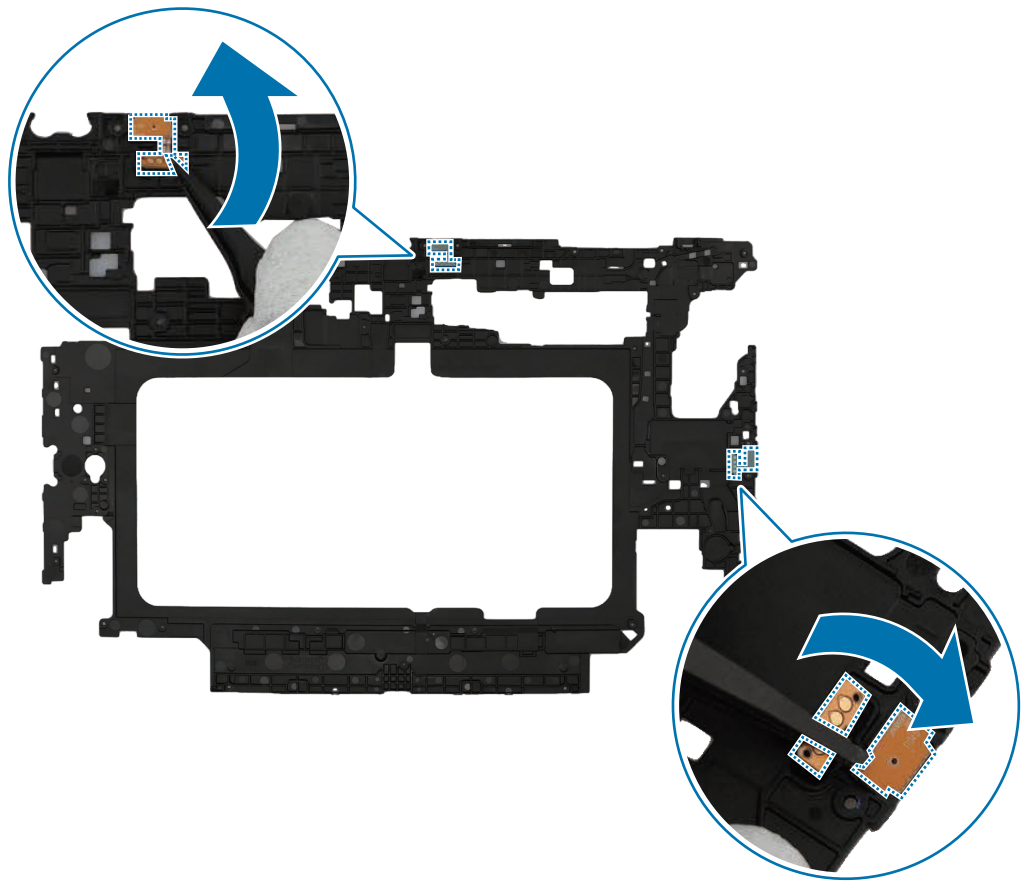

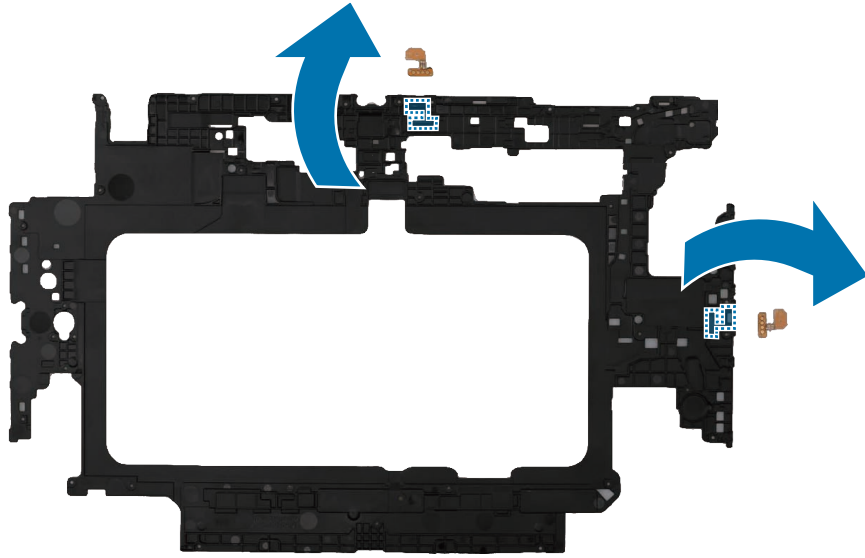

Reassembly

 Leaving screws inside the device may damage internal components, such as the battery. When assembling, be extra careful not to leave any unassembled screws inside the device.

1 Using the tweezers and your fingers, remove all release films of new microphone adhesive tapes.

 Be careful not to damage the microphones.

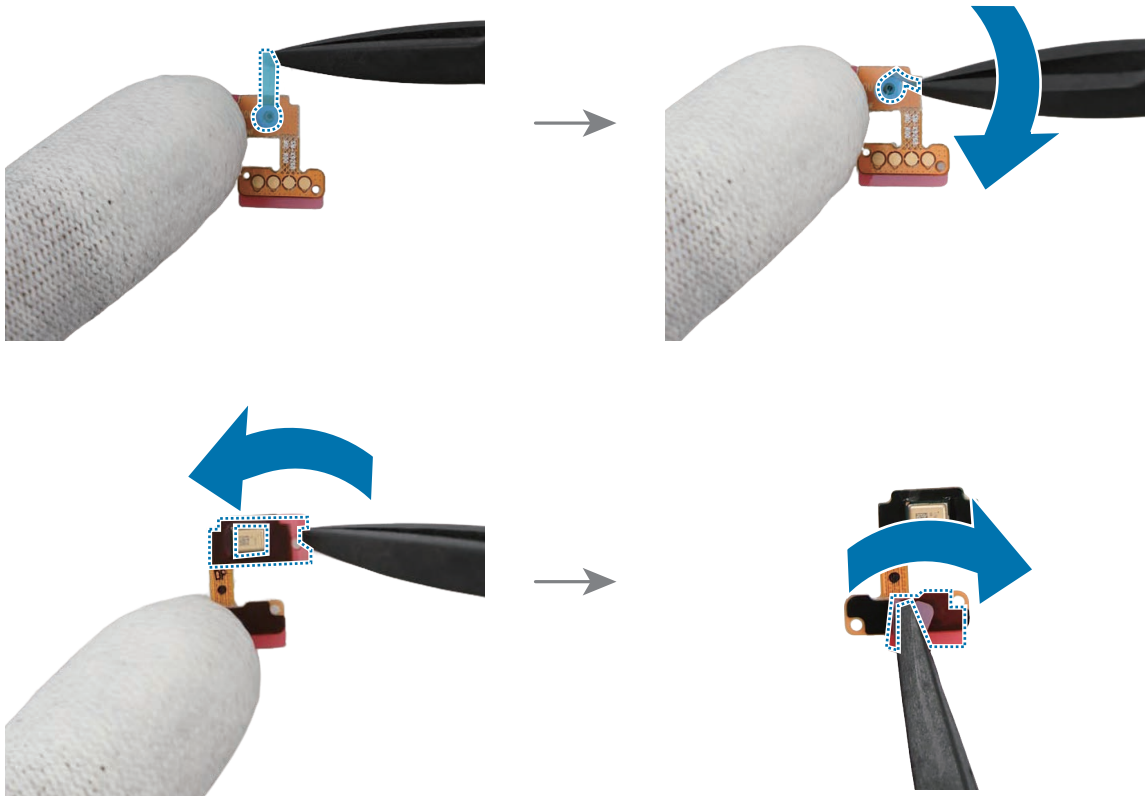

2 Using the tweezers, align the top microphone with the position of the microphone hole and attach it accurately.

⚠ Be careful not to damage the microphone and bracket.



3 Press the top microphone with your fingers softly so that the microphone can be completely attached.

⚠ Be careful not to damage the microphone and bracket.

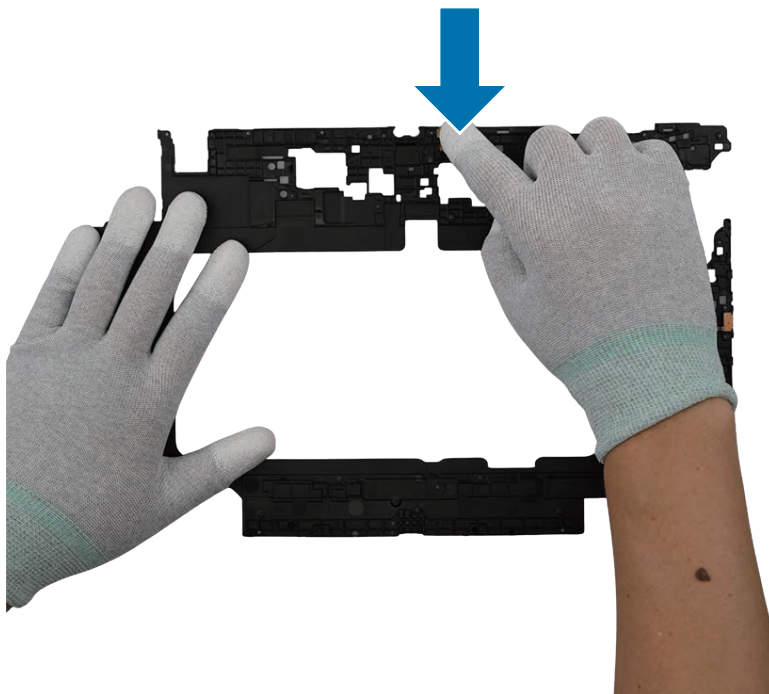

4 Using the tweezers, align the side microphone with the position of the microphone hole and attach it accurately.

⚠ Be careful not to damage the microphone and bracket.

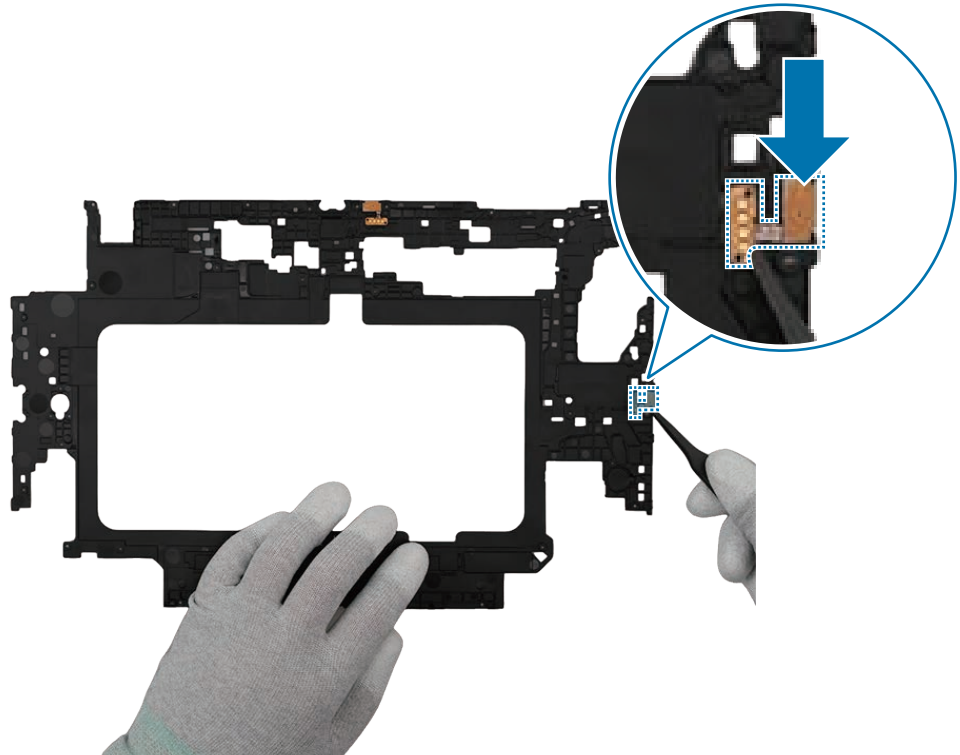

5 Press the side microphone with your fingers softly so that the microphone can be completely attached.

⚠ Be careful not to damage the microphone and bracket.



👉 Reassemble the [Bracket](#) and [Screen](#) to complete assembly.

Charging Port

Disassembly

 Remove the [Screen](#) and [Bracket](#) first before you begin.

1 Using the tweezers, disconnect the battery connector from the main board first. Separate the 2 connectors and the coaxial cable connector (Black) from the main board. For the 5G or LTE devices, separate the additional 4 coaxial cable connectors (Blue/White/Orange/Red).

 • Make sure to first disconnect the battery connector for your own safety.
• Be careful not to damage the battery.

 • Be careful not to damage the cable while removing the connector.
• Be careful not to damage the near components.

 • The 4 coaxial cables (Blue/White/Orange/Red) are only available for the 5G or LTE devices.
• The cables and connectors may vary depending on the country, region, or specifications.

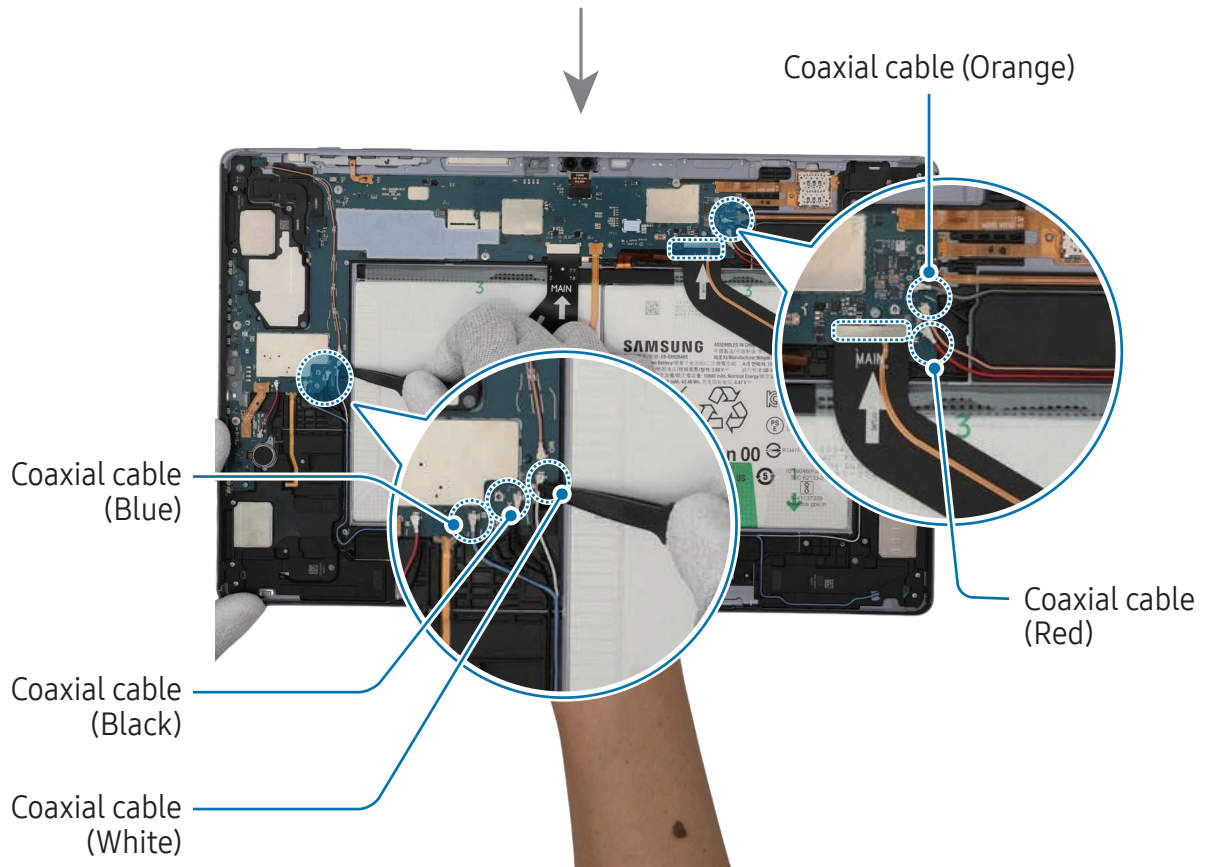
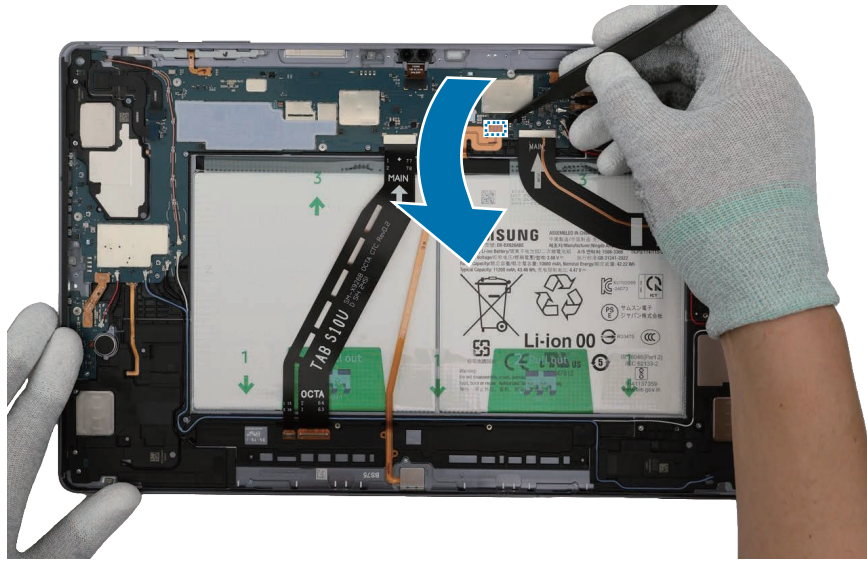

2 Check and remove the screws at the 3 different points on the charging port using a cross-head screwdriver.

⚠ Be careful not to damage the near components.

📝 Check the number of screws that have been removed, and store them carefully to make sure that no unassembled screws are left inside the device during assembly.

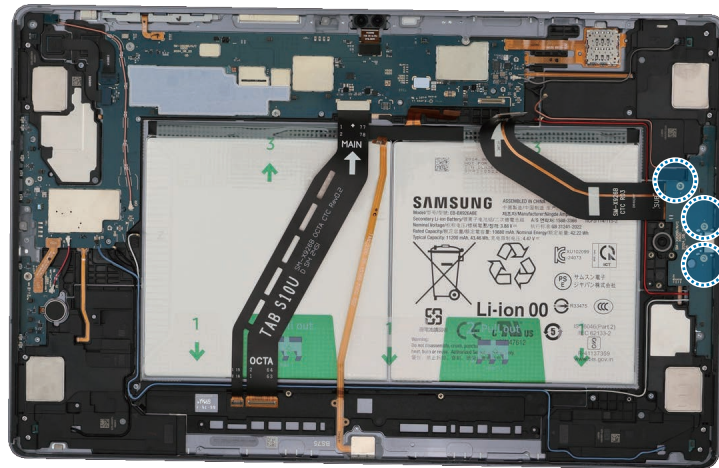

3 For the 5G or LTE devices, disconnect the 4 coaxial cables (Blue/White/Orange/Red) in the speaker modules with the tweezers. Using the tweezers, lift up on the separator groove of the charging port module and remove it carefully.

⚠ • Check the position of the overlapping cables and disconnect them in order from the top.

• Be careful not to damage the cable while removing the connector.

• Be careful not to damage the near components.

📝 • The 4 coaxial cables (Blue/White/Orange/Red) are only available for the 5G or LTE devices.

• The cables and connectors may vary depending on the country, region, or specifications.

Disassembly and Assembly

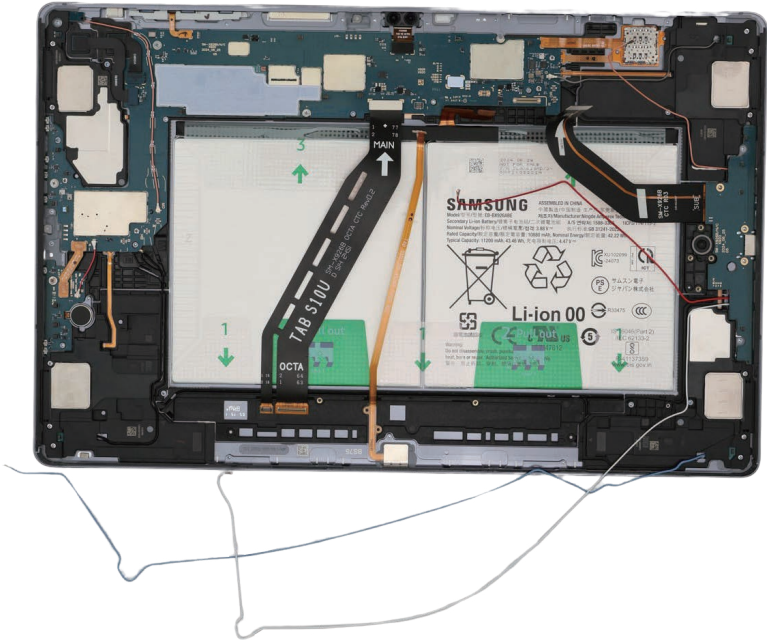
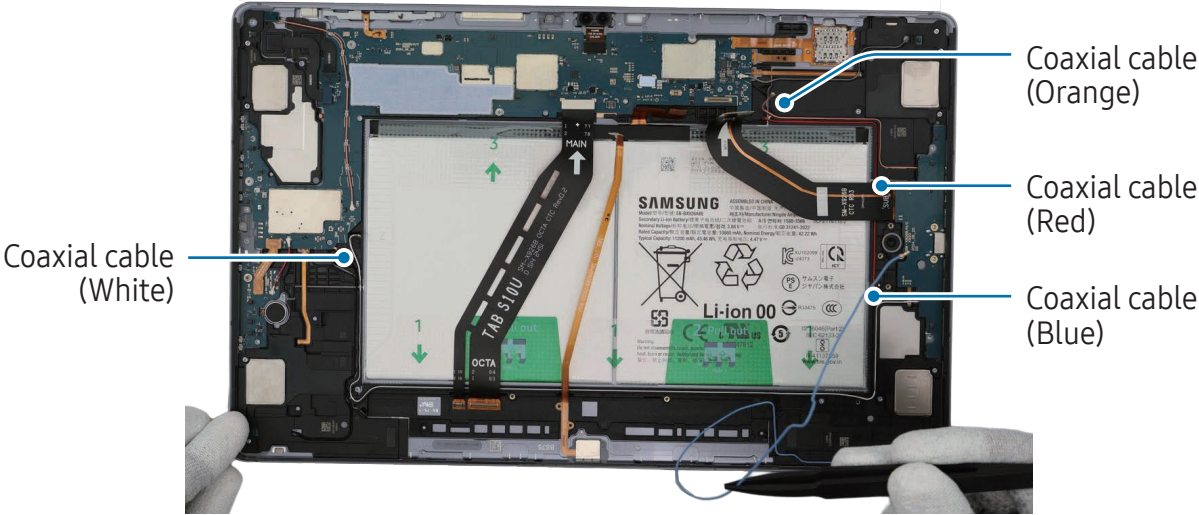

4 For the 5G or LTE devices, disconnect the coaxial cable connector (White) on the back of the charging port with the tweezers.

- ⚠ • Be careful not to damage the near components.
- Be careful not to damage the cable while removing the connector.
- ✓ • The coaxial cable (White) is only available for the 5G or LTE devices.
- The cables and connectors may vary depending on the country, region, or specifications.

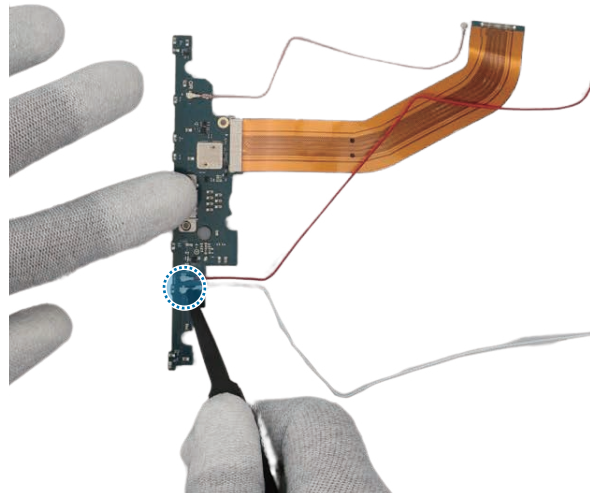

5 For the 5G or LTE devices, disconnect the coaxial cable connector (Red) on the back of the charging port with the tweezers.

- ⚠ • Be careful not to damage the near components.
- Be careful not to damage the cable while removing the connector.
- ✔ • The coaxial cable (Red) is only available for the 5G or LTE devices.
- The cables and connectors may vary depending on the country, region, or specifications.

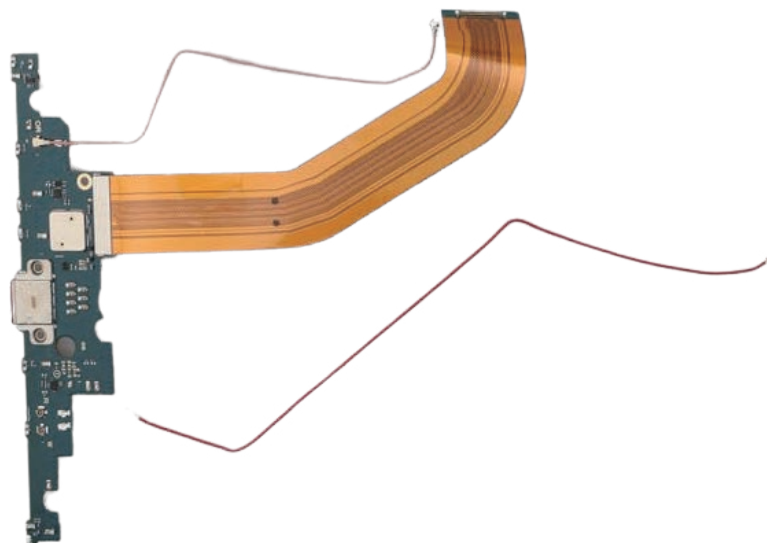
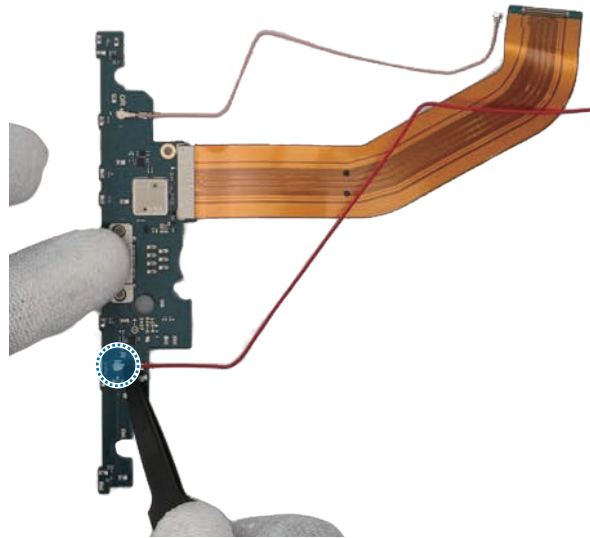

6 For the 5G or LTE devices, disconnect the coaxial cable connector (Orange) on the back of the charging port with the tweezers.

- ⚠ • Be careful not to damage the near components.
- Be careful not to damage the cable while removing the connector.
- ✓ • The coaxial cable (Orange) is only available for the 5G or LTE devices.
- The cables and connectors may vary depending on the country, region, or specifications.

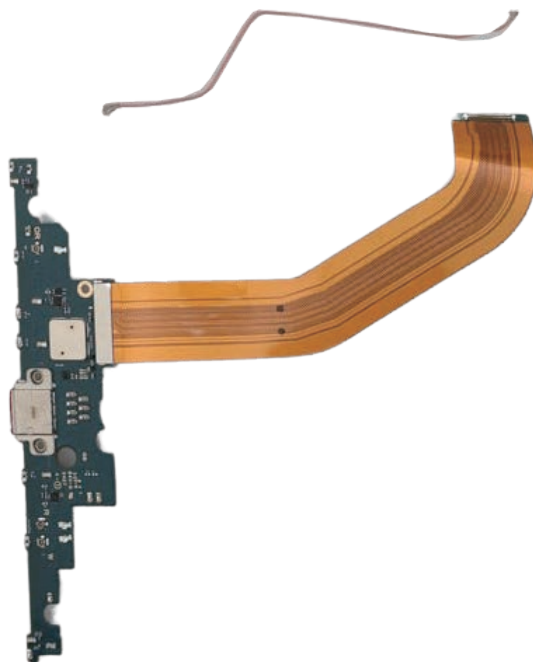
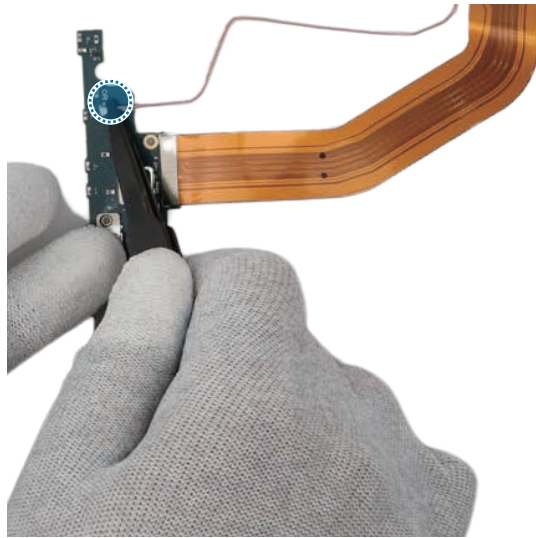

7 Using the tweezers, disconnect the connector on the back of the charging port.



- Be careful not to damage the near components.
- Be careful not to damage the cable while removing the connector.

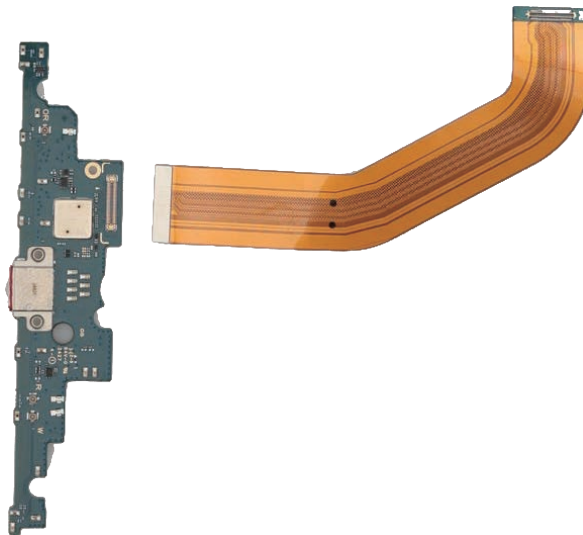
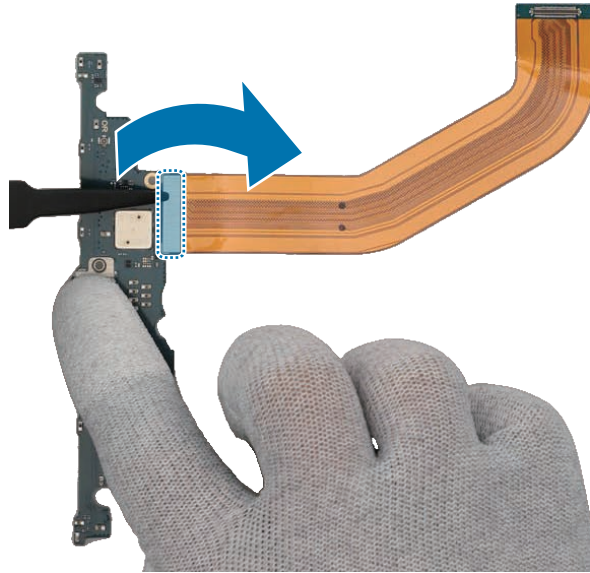

Reassembly

 Leaving screws inside the device may damage internal components, such as the battery. When assembling, be extra careful not to leave any unassembled screws inside the device.

1 Using the tweezers, connect the connector on the back of the charging port.

-  Be careful not to damage the charging port and near components.
- Be careful not to damage the cable while connecting the connector.

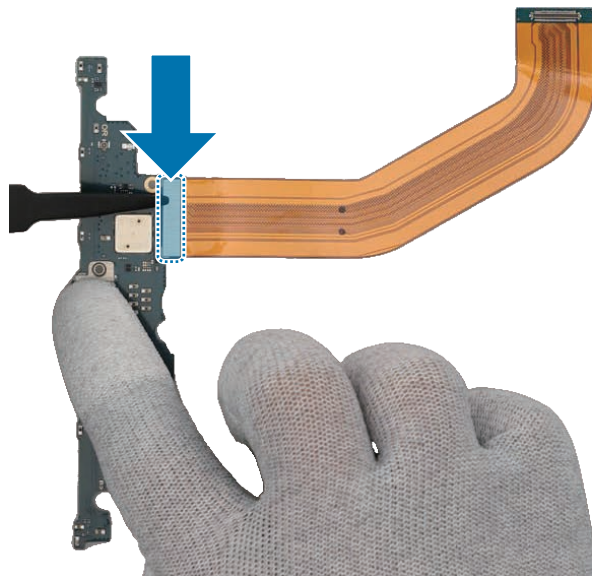

2 For the 5G or LTE devices, connect the coaxial cable connector (Orange) on the back of the charging port with the tweezers.

- ⚠ • Be careful not to damage the charging port and near components.
- Be careful not to damage the cable while connecting the connector.
- ✓ • The coaxial cable (Orange) is only available for the 5G or LTE devices.
- The cables and connectors may vary depending on the country, region, or specifications.

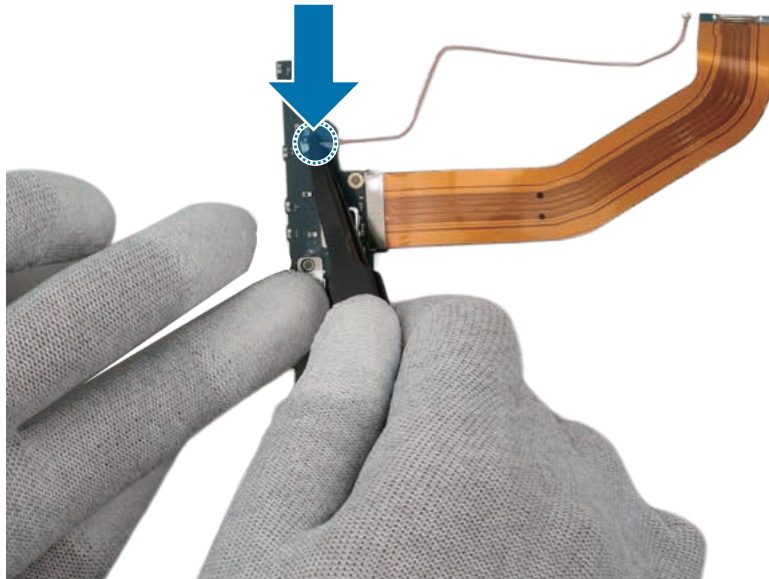

3 For the 5G or LTE devices, connect the coaxial cable connector (Red) on the back of the charging port with the tweezers.

- ⚠ • Be careful not to damage the charging port and near components.
- Be careful not to damage the cable while connecting the connector.
- ✔ • The coaxial cable (Red) is only available for the 5G or LTE devices.
- The cables and connectors may vary depending on the country, region, or specifications.

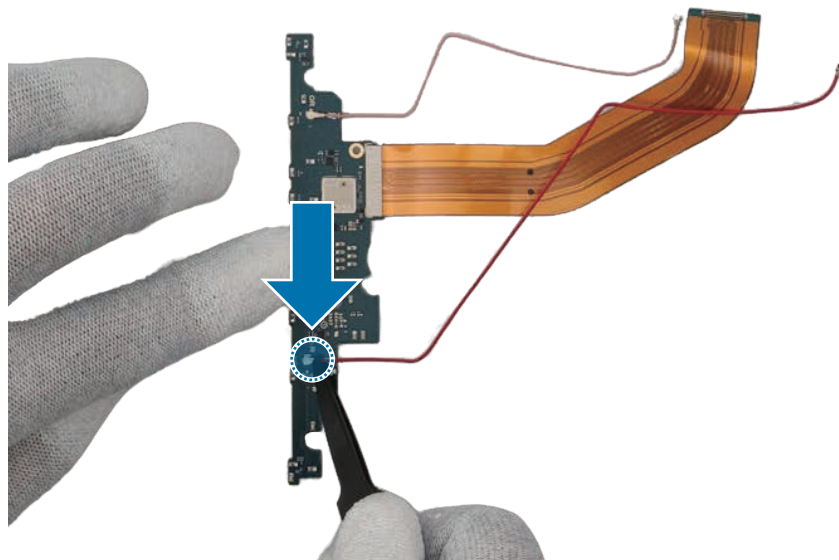

4 For the 5G or LTE devices, connect the coaxial cable connector (White) on the back of the charging port with the tweezers.

- ⚠ • Be careful not to damage the charging port and near components.
- Be careful not to damage the cable while connecting the connector.
- ✔ • The coaxial cable (White) is only available for the 5G or LTE devices.
- The cables and connectors may vary depending on the country, region, or specifications.

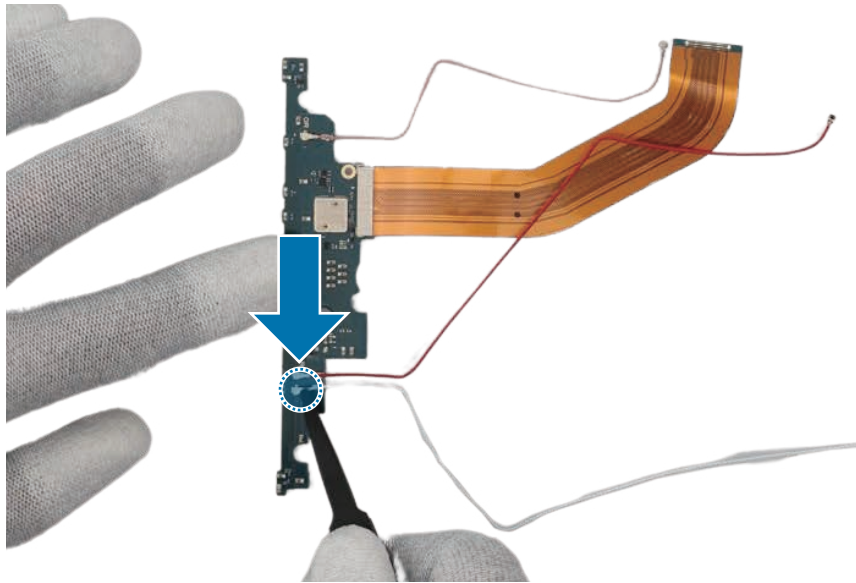

5 Using the tweezers or your fingers, assemble the charging port to the back cover module and press down softly and evenly on it so that the charging port can be completely attached.

- ❗ • Be careful not to damage the charging port module side contact.
- Be careful not to damage the near components.

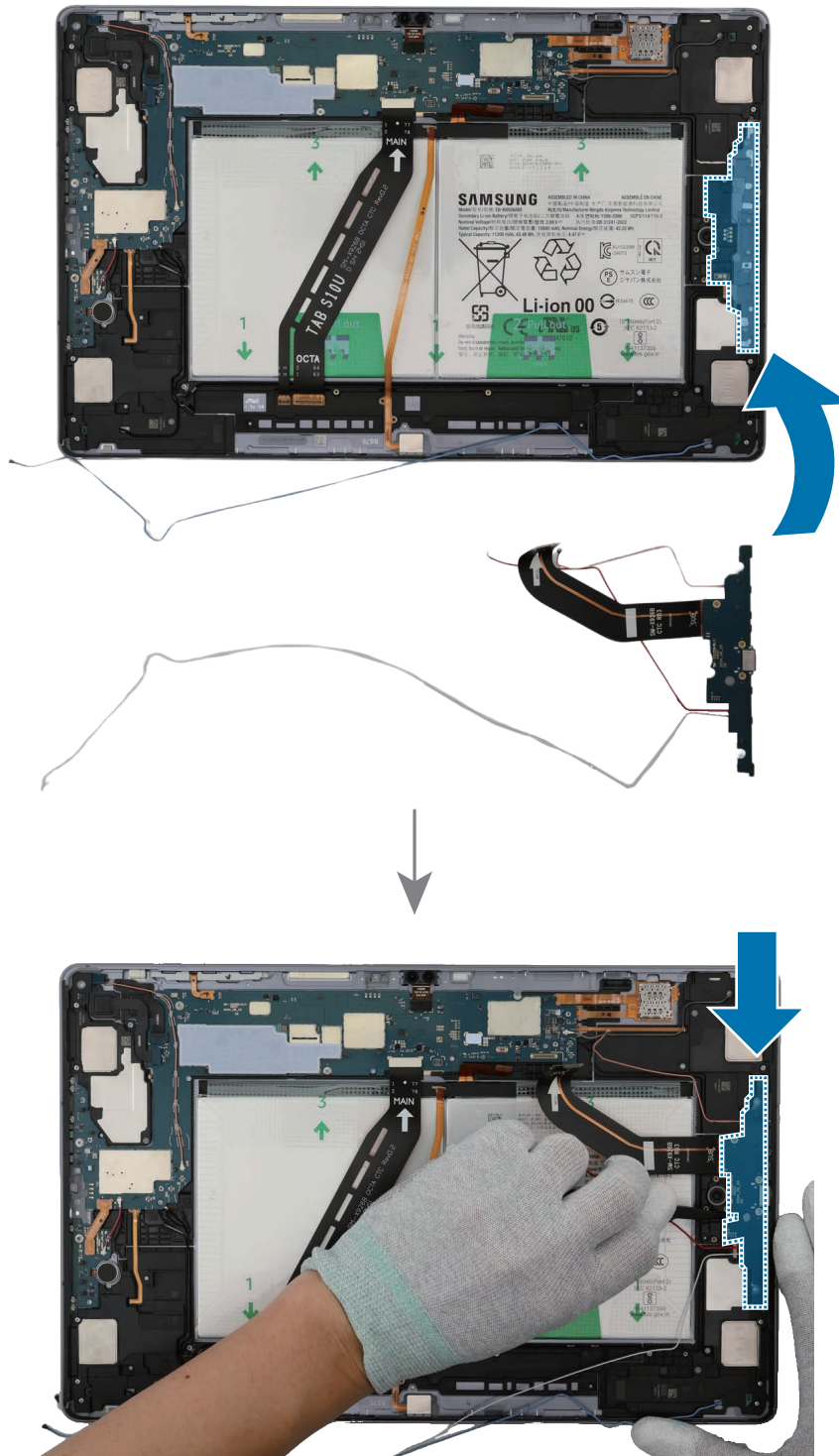

6 For the 5G or LTE devices, carefully connect the cables (Orange/Red/White/Blue) to the speaker modules.



- Be careful not to damage the charging port and near components.
- Be careful not to damage the cables.



- The 4 coaxial cables (Orange/Red/White/Blue) are only available for the 5G or LTE devices.
- The cables and connectors may vary depending on the country, region, or specifications.

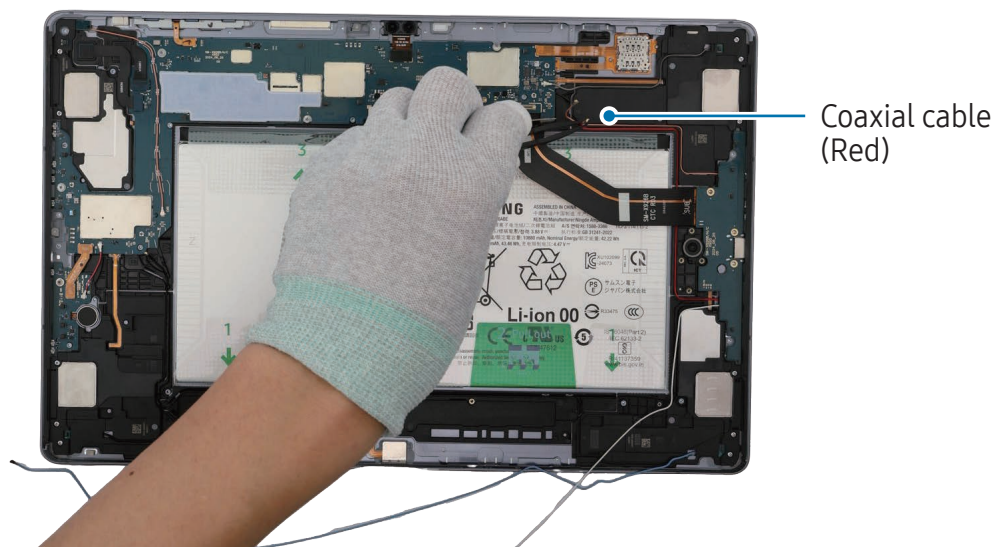
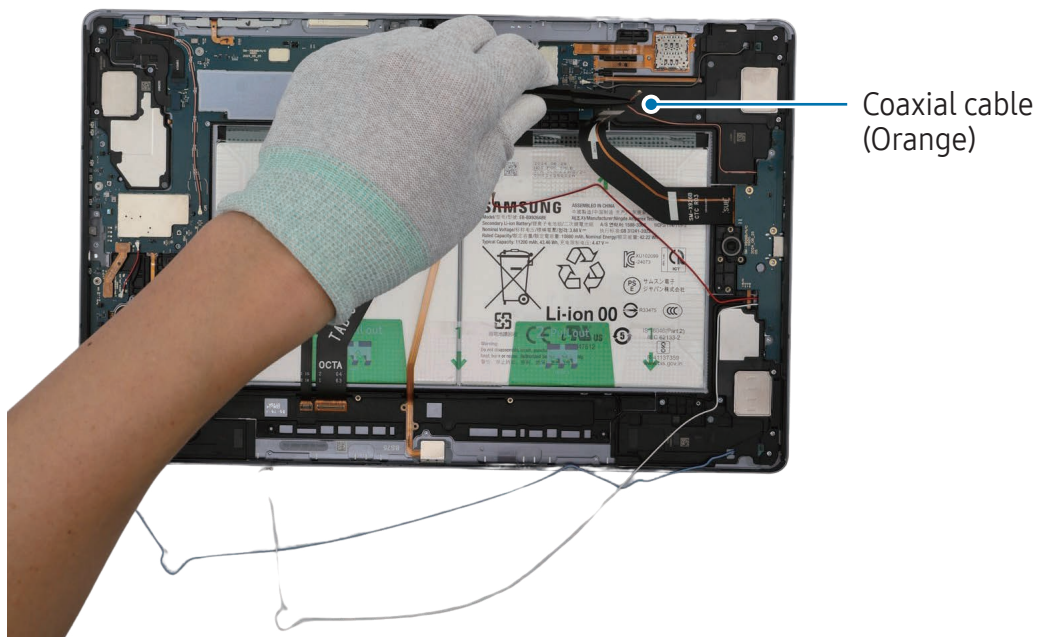

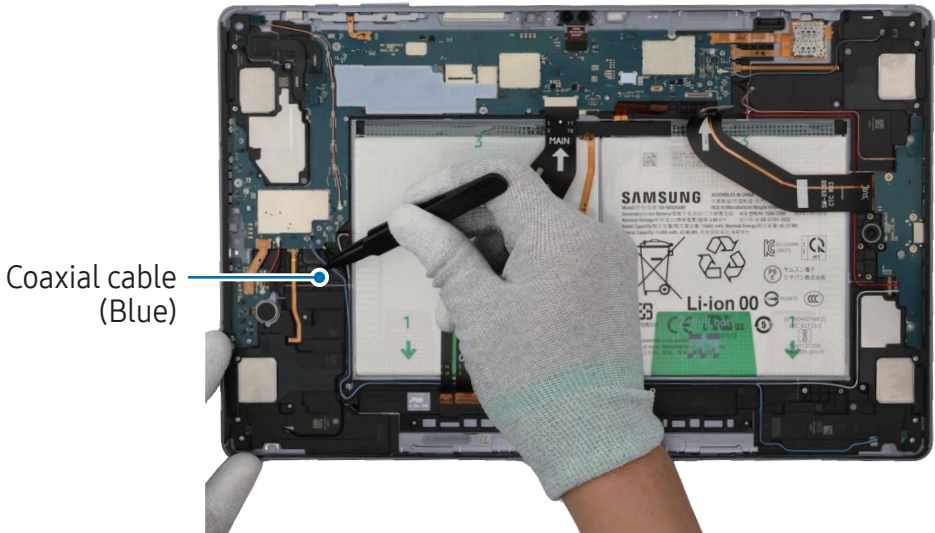
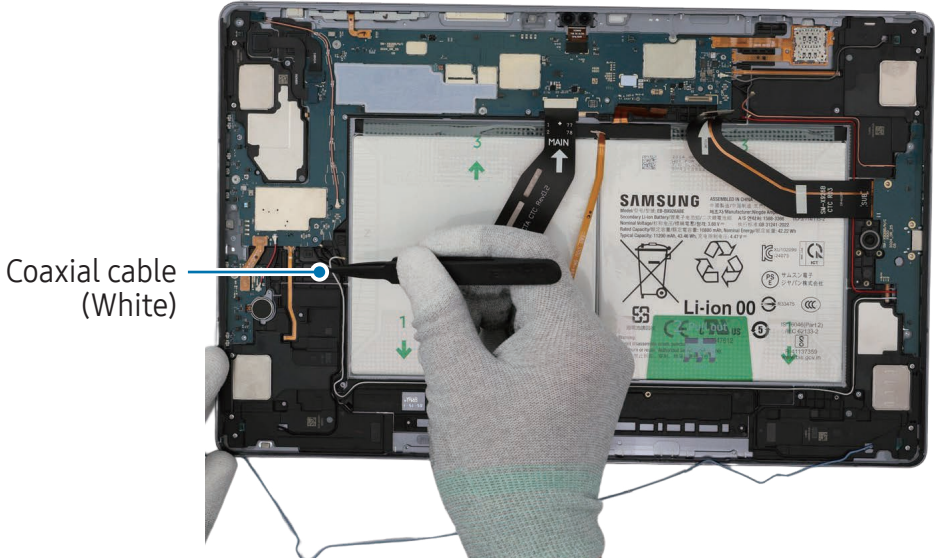

7 Check the screw 3443 (3 ea) and fasten them on the charging port using a cross-head screwdriver.

⚠ Be careful not to damage the charging port and near components.

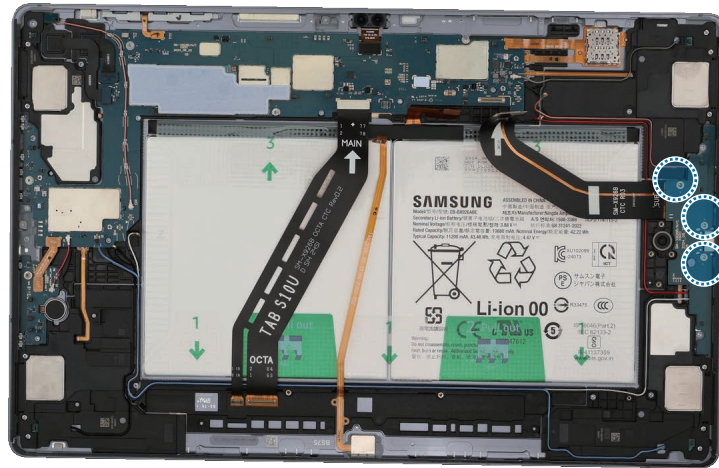

8 Using the tweezers, connect the 2 connectors and the coaxial cable connector (Black) to the main board. For the 5G or LTE devices, connect the 4 coaxial cable connectors (Blue/White/Orange/Red).



- Be careful not to damage the charging port and near components.
- Be careful not to damage the cable while connecting the connector.



- The 4 coaxial cables (Blue/White/Orange/Red) are only available for the 5G or LTE devices.
- The cables and connectors may vary depending on the country, region, or specifications.

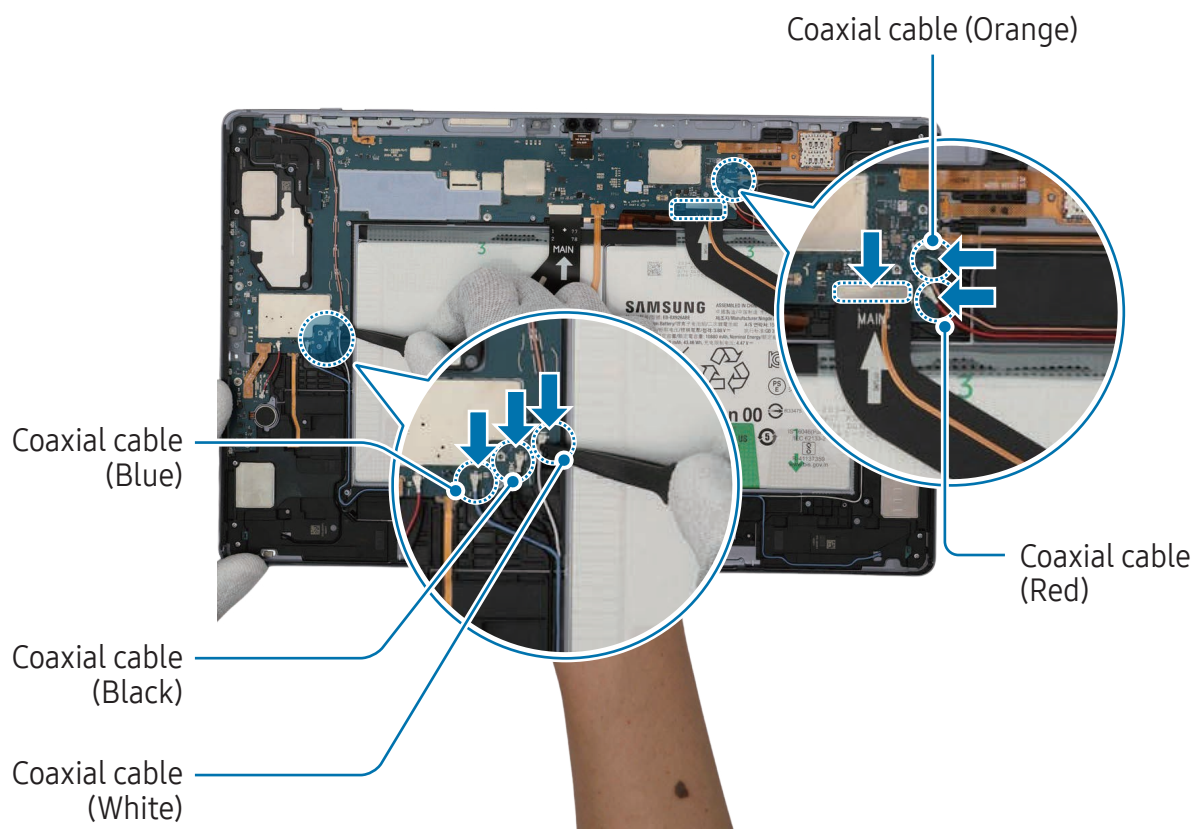

9 Using the tweezers, connect the battery connector to the main board.

⚠ Be careful not to damage the battery.

⚠ Be careful not to damage the battery connector and near components.

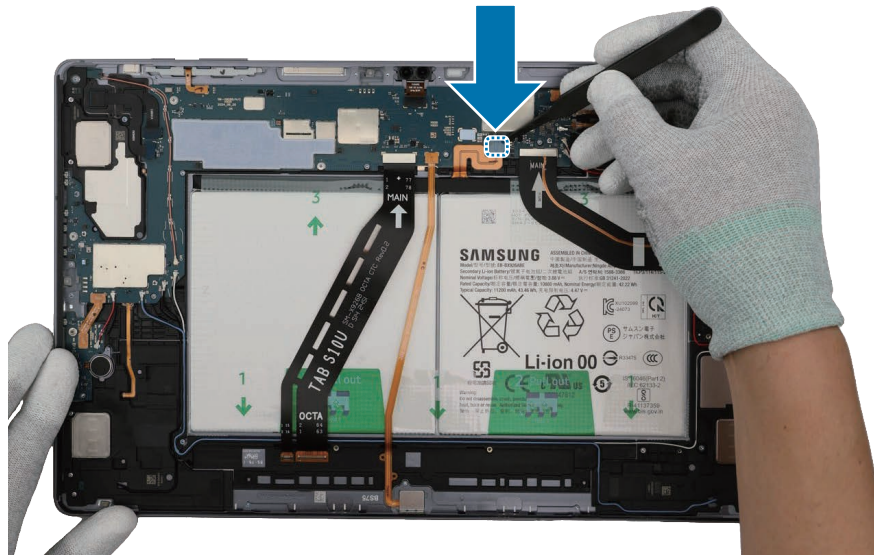

👉 Reassemble the **Bracket** and **Screen** to complete assembly.

Rear Camera

Disassembly

 Remove the [Screen](#) and [Bracket](#) first before you begin.

1 Using the tweezers, disconnect the battery connector from the main board.

-  Make sure to first disconnect the battery connector for your own safety.
- Be careful not to damage the battery.

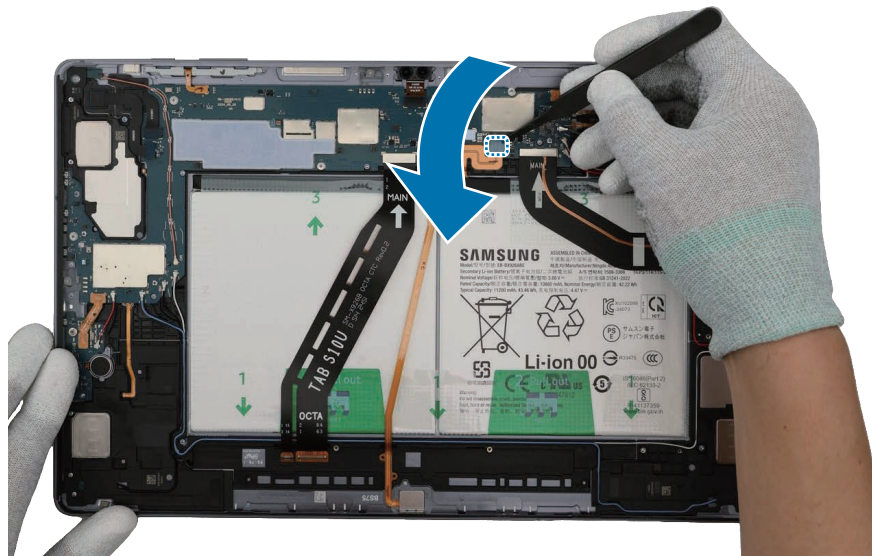

- Using the tweezers, disconnect the coaxial cable connector (Orange) and 2 rear camera cable connectors from the main board. Using the tweezers, lift the separator groove up to the top of the rear camera module and remove the 2 rear cameras one by one. Leave the camera lens facing up.

⚠ Be careful not to damage the main board and near components.

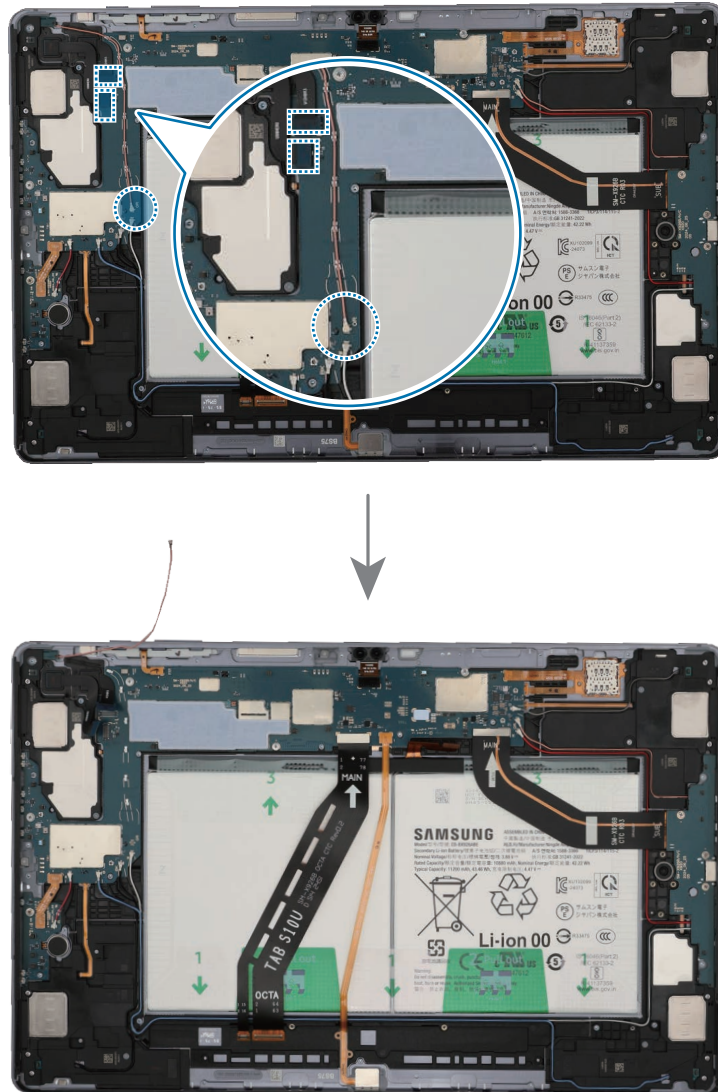

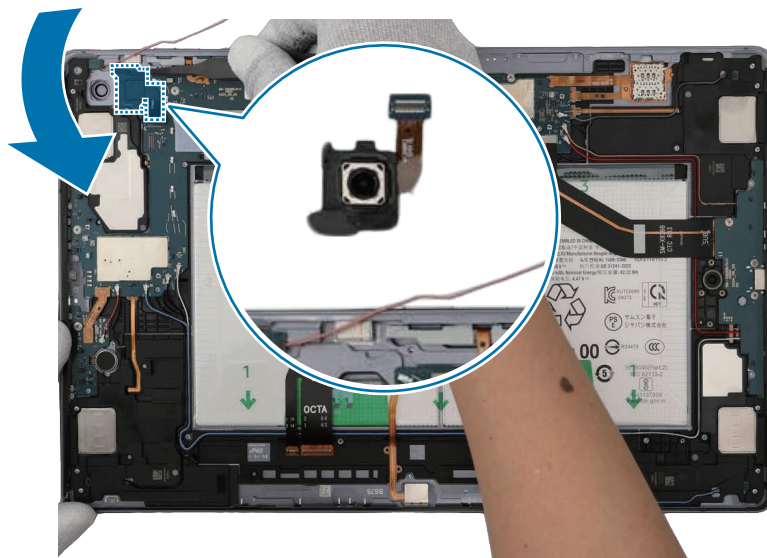
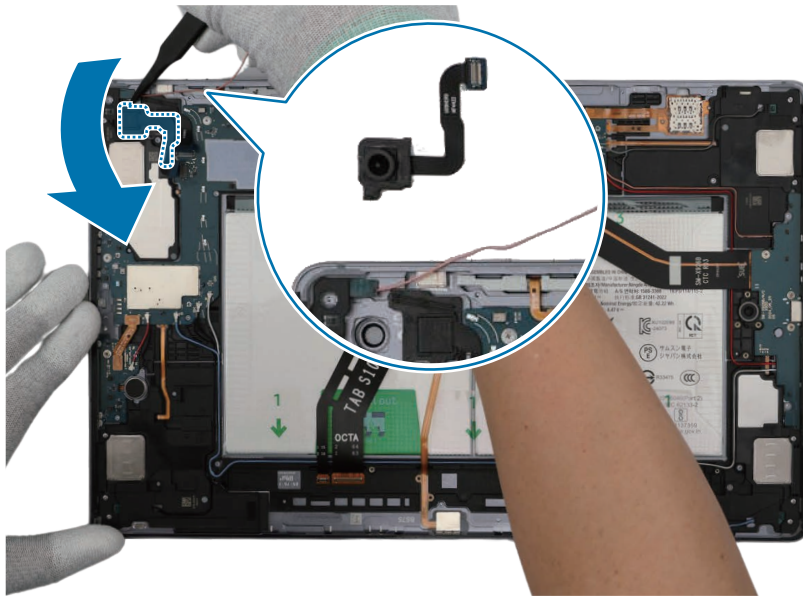

Reassembly

⚠ Leaving screws inside the device may damage internal components, such as the battery. When assembling, be extra careful not to leave any unassembled screws inside the device.

1 Using the tweezers and your fingers, remove all release films from the new rear cameras. Using the tweezers or your fingers, gently insert the 2 rear camera modules one by one in the camera holes so that the lens faces backward.

- ⚠** • Make sure to place the camera in the correct position.
- Be careful not to damage the camera lens and near components.
- Be careful not to damage and scratch the camera module.

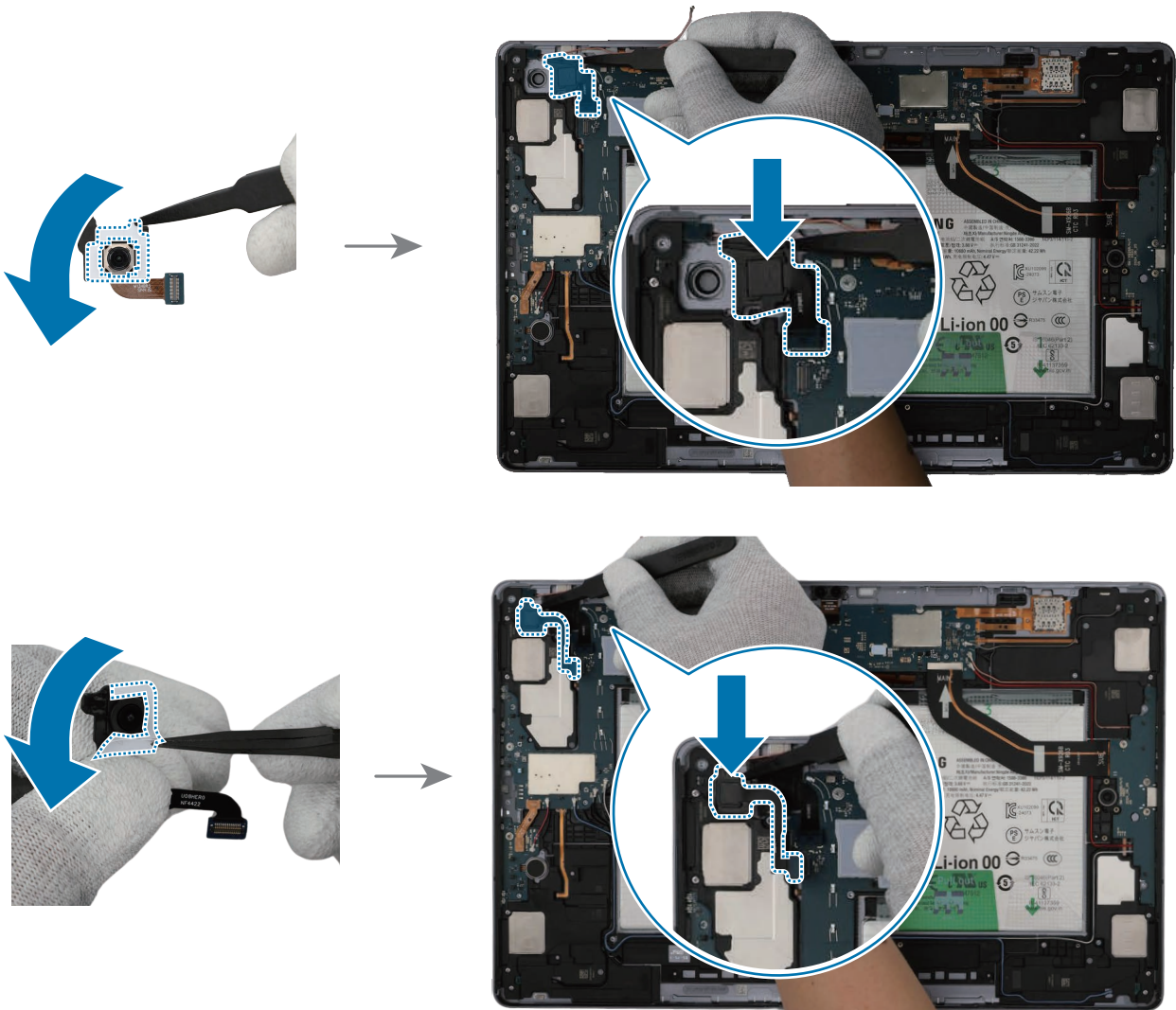

- 2 Press down softly and evenly on the camera modules so that the rear cameras can be fully inserted.

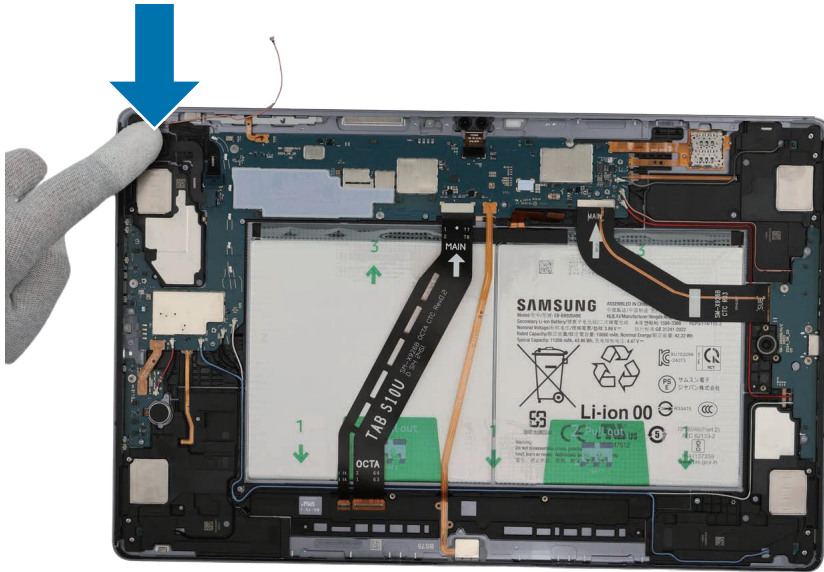

- 3 Using the tweezers, connect the coaxial cable connector (Orange) and 2 rear camera cable connectors to the main board.

- ⚠ Be careful not to damage the cable while connecting the connector.
- Be careful not to damage the near components.

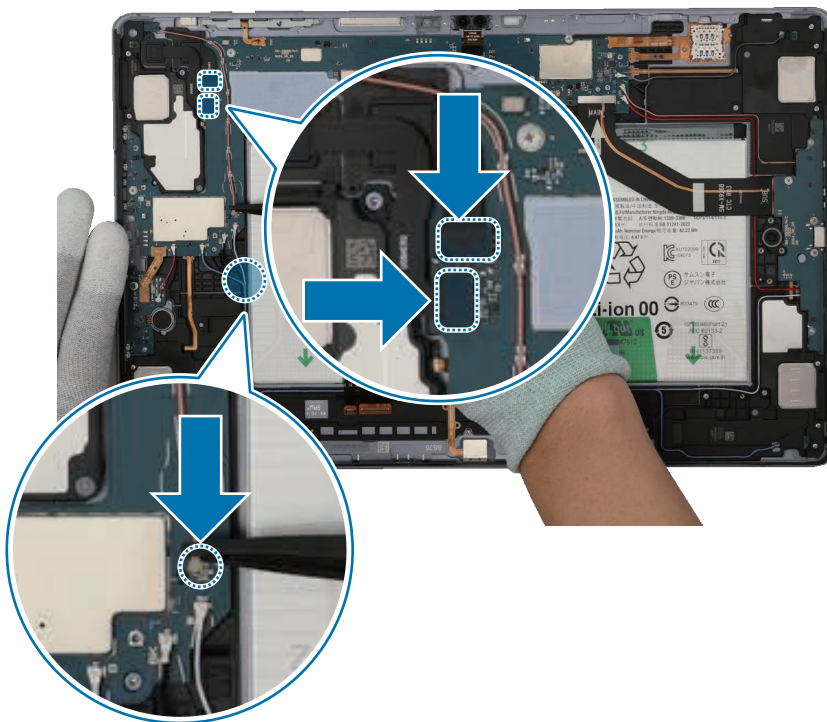

4 Using the tweezers, connect the battery connector to the main board.

⚠ Be careful not to damage the battery.

⚠ Be careful not to damage the battery connector and near components.

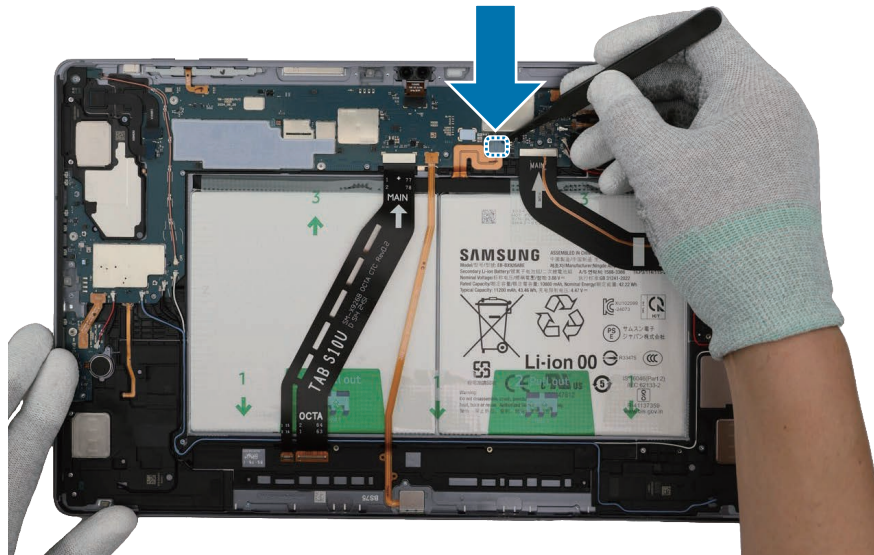

👉 Reassemble the **Bracket** and **Screen** to complete assembly.

Front Camera

Disassembly

 Remove the [Screen](#) and [Bracket](#) first before you begin.

1 Using the tweezers, disconnect the battery connector from the main board.

-  • Make sure to first disconnect the battery connector for your own safety.
- Be careful not to damage the battery.

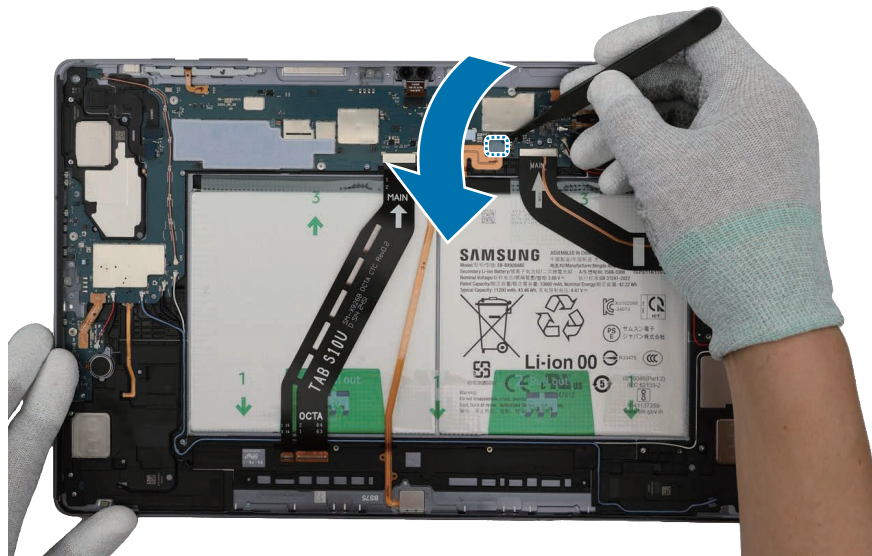

- Using the tweezers, separate the front camera connector from the main board and remove the front camera carefully from the device. Leave the camera lens facing up.

⚠ Be careful not to damage the main board and near components.

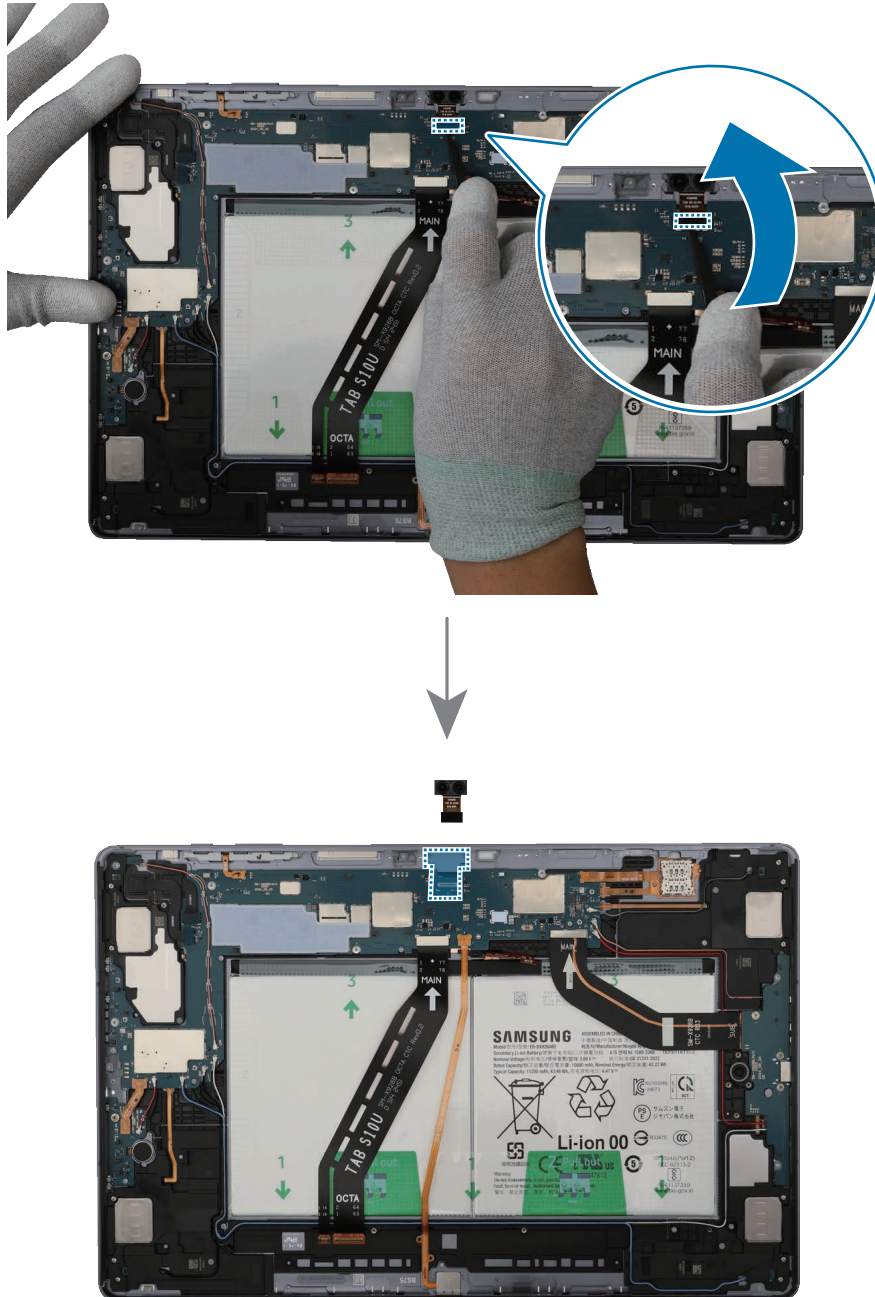

Reassembly

 Leaving screws inside the device may damage internal components, such as the battery. When assembling, be extra careful not to leave any unassembled screws inside the device.

1 Using the tweezers, remove all release films from the new front camera module. Using the tweezers or your fingers, place the front camera in the camera hole so that the lens faces upward, and gently insert the front camera.

-  • Be careful not to damage the camera lens and near components.
- Be careful not to damage and scratch the camera module.

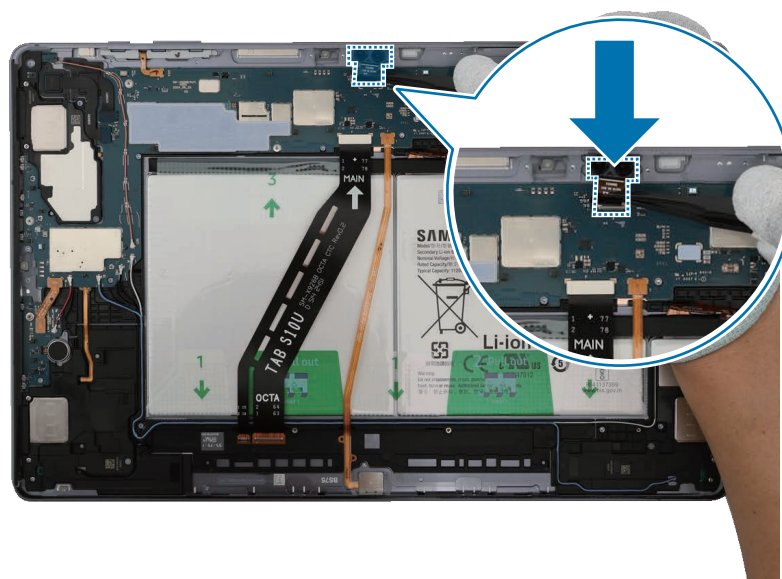

2 Using the tweezers, connect the front camera connector carefully to the main board.

⚠ Be careful not to damage the front camera and near components.

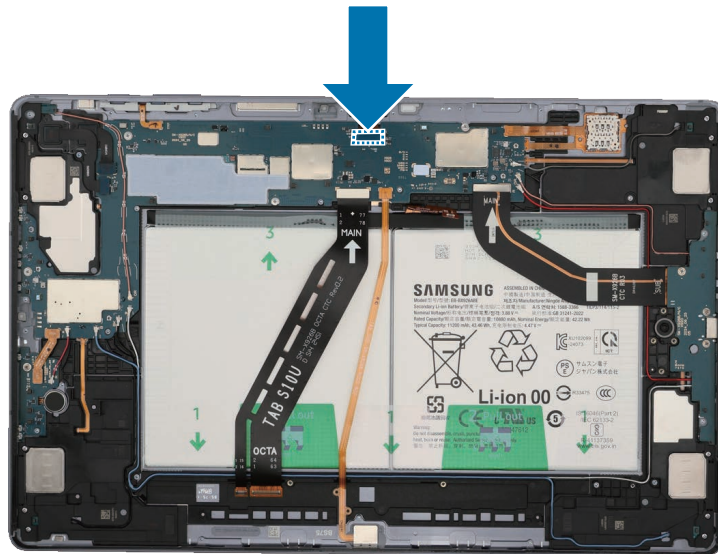

3 Using the tweezers, connect the battery connector to the main board.

⚠ Be careful not to damage the battery.

⚠ Be careful not to damage the battery connector and near components.

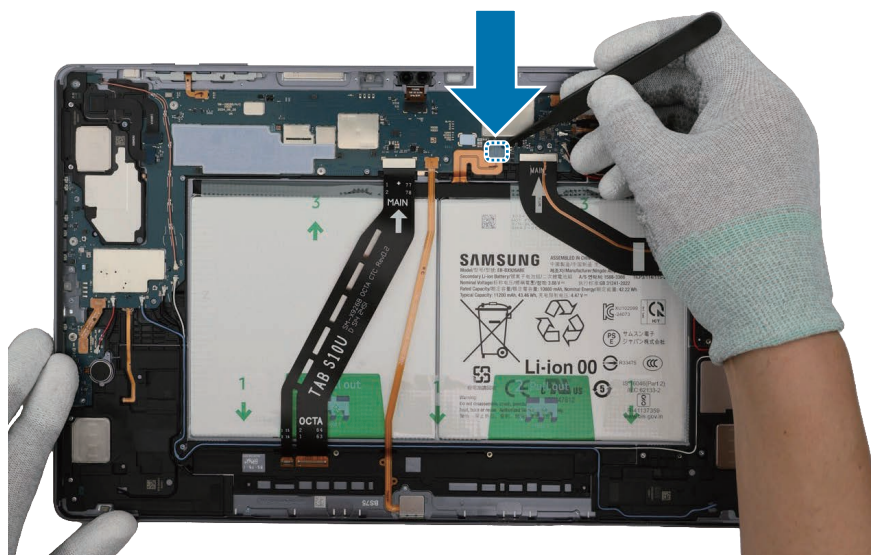

📝 Reassemble the **Bracket** and **Screen** to complete assembly.

Speaker1

Disassembly

 Remove the [Screen](#) and [Bracket](#) first before you begin.

1 Using the tweezers, disconnect the battery connector from the main board first. Separate the 8 connectors and the 3 coaxial cable connectors (Orange/Black/Red) from the main board. For the 5G or LTE devices, separate the additional 5 coaxial cable connectors (Blue/White/Grey/Orange/Red).

 • Make sure to first disconnect the battery connector for your own safety.
• Be careful not to damage the battery.

 • Be careful not to damage the cable while removing the connector.
• Be careful not to damage the near components.

 • The 5 coaxial cables (Blue/White/Grey/Orange/Red) are only available for the 5G or LTE devices.
• The cables and connectors may vary depending on the country, region, or specifications.

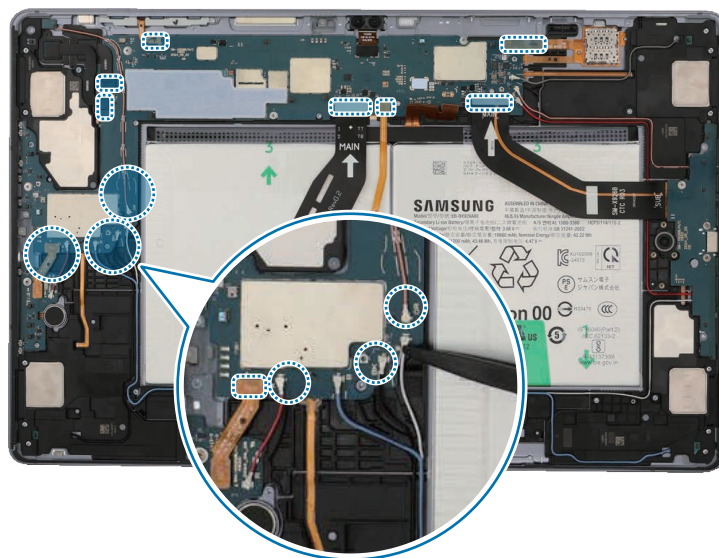
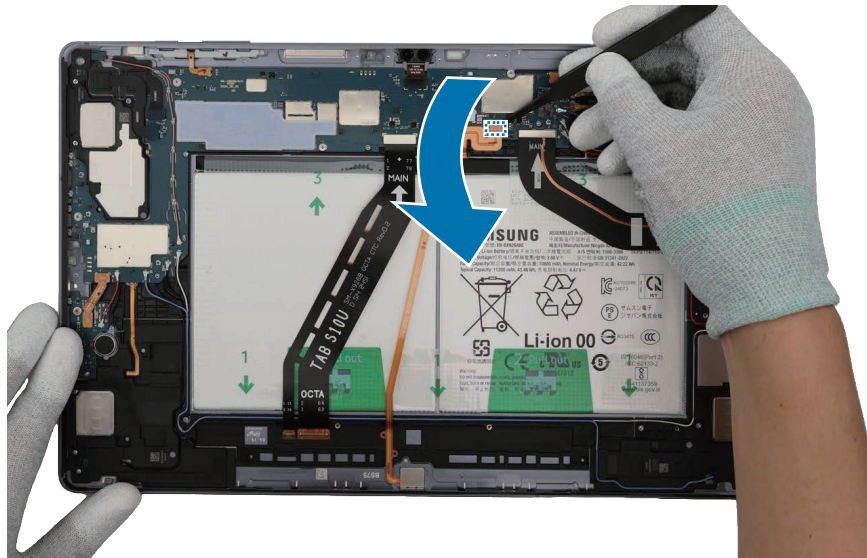

Disassembly and Assembly

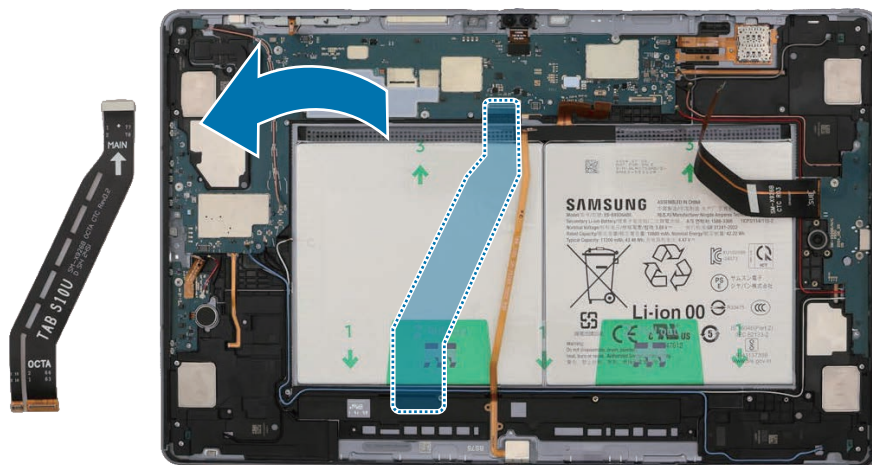
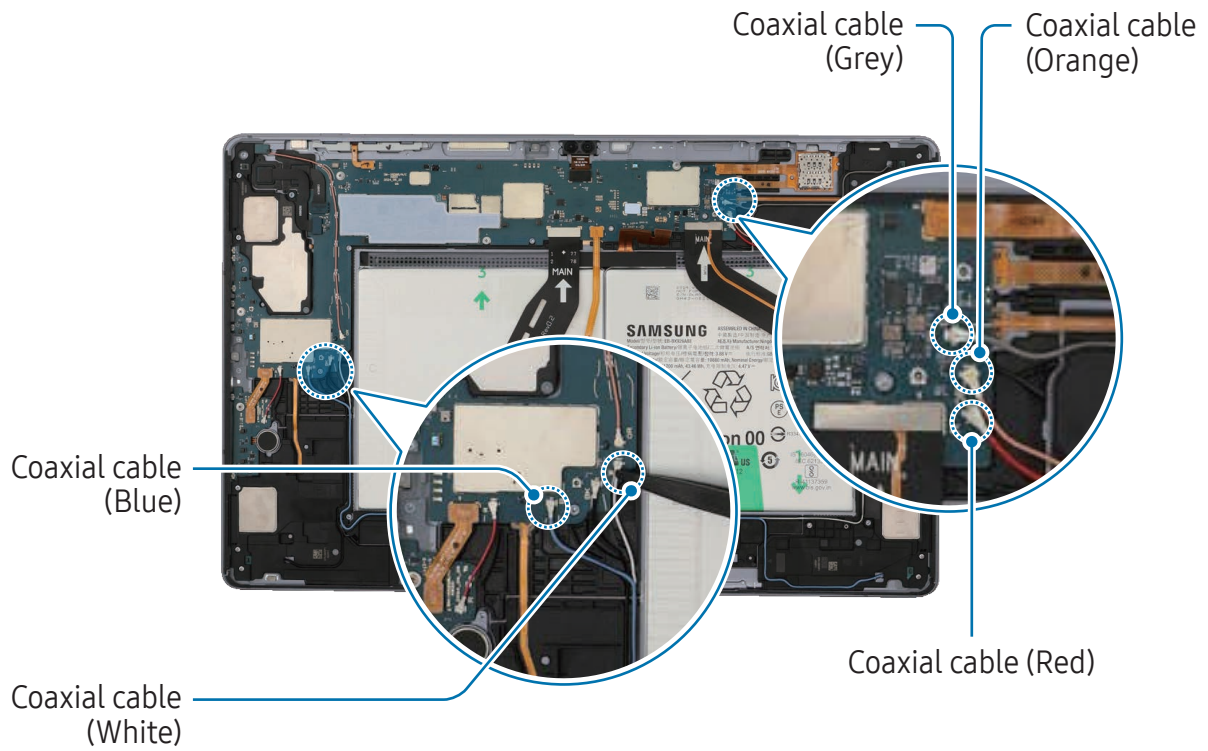

2 Check the 4 screws on the main board, the screw on the Wi-Fi board, and the 3 screws on the speaker. Remove all 8 screws using a cross-head screwdriver.

⚠ Be careful not to damage the main board and near components.

📝 Check the number of screws that have been removed, and store them carefully to make sure that no unassembled screws are left inside the device during assembly.

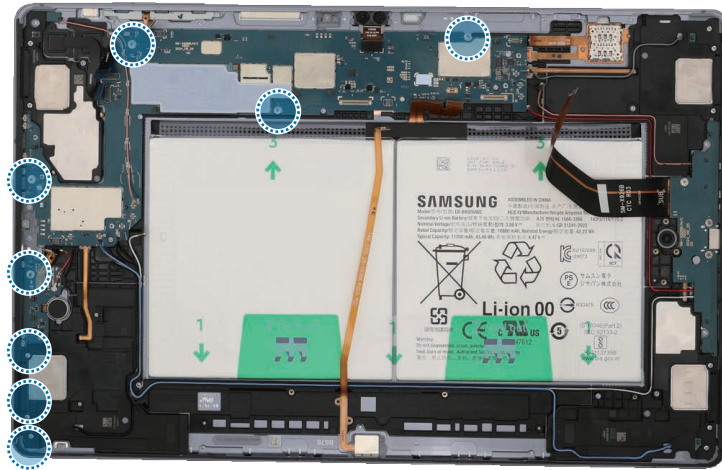

3 Using the tweezers, disconnect the coaxial cable (Orange) from the main board. Then, lift up on the separator groove of the main board and remove the main board module.

- ⚠ • Be careful not to damage the battery connector, the main board, and near components.
- The cables have to be positioned outside so as not to interfere when disassembling the main board.

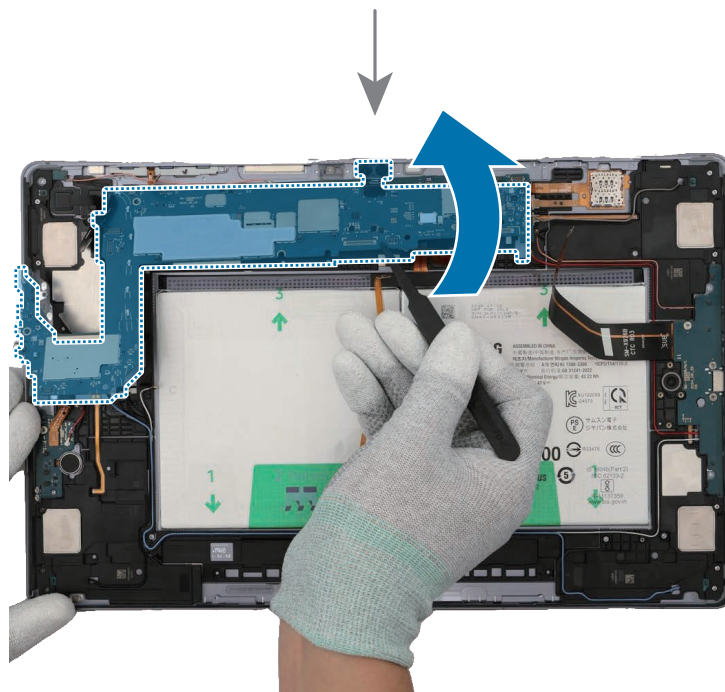
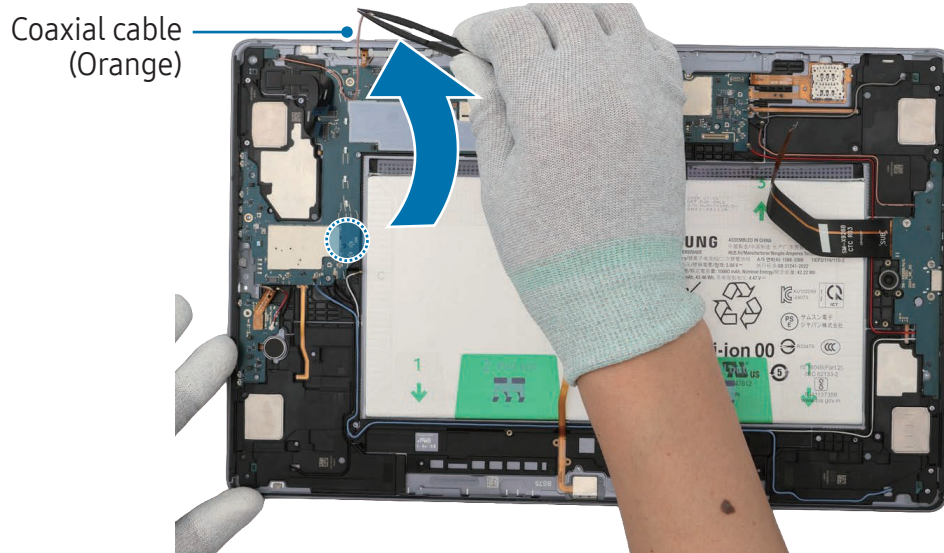

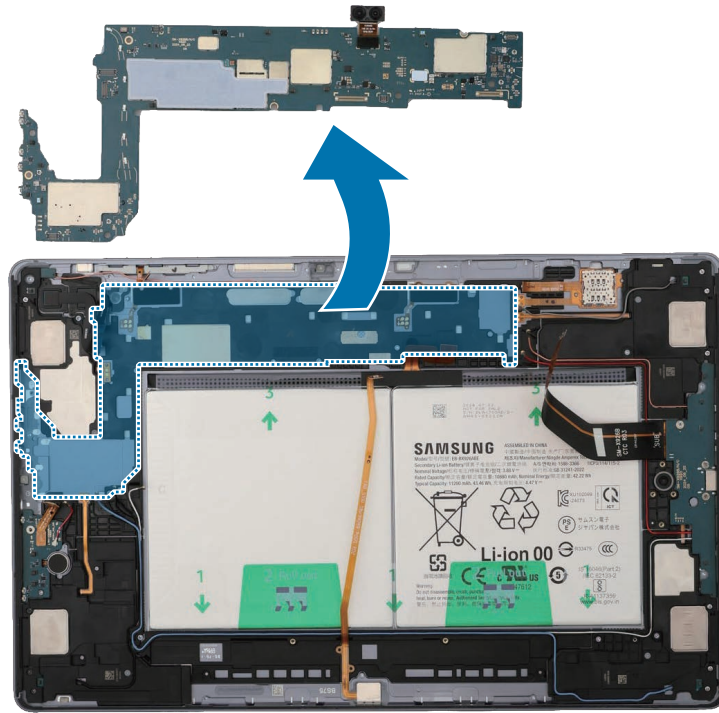

- Using the tweezers, lift up the Wi-Fi board from the back cover module and remove it.

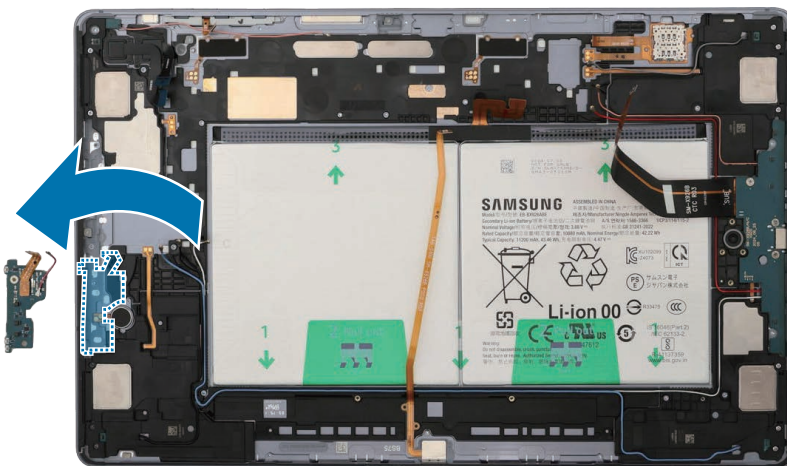
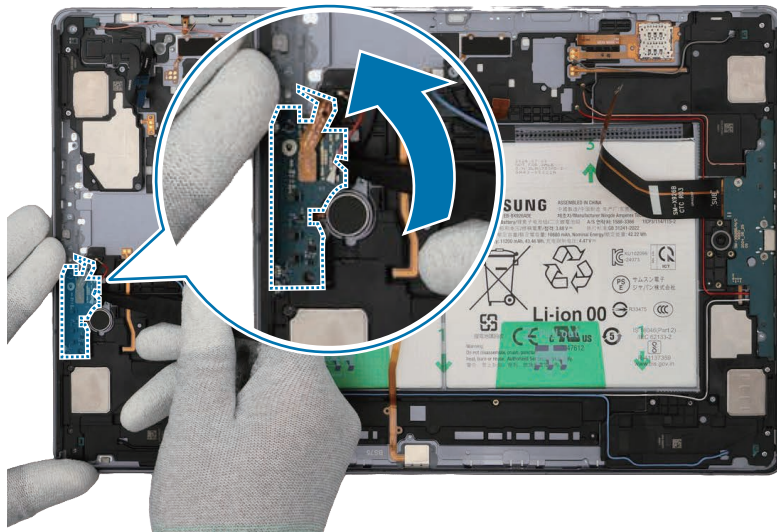

5 Heat the microwaveable heating bag and apply it to the both front and back side of the speaker module for 4 minutes.

- ⚠ • It is possible for the device or battery to be damaged by heat.
- Do not heat the device in a microwave. Doing so could cause an explosion.
- ⚠ • Follow the heating bag's instructions for heating. The recommended time for heating the bag is 50 seconds in a 1000 W microwave and 70 seconds in a 700 W microwave. (Correct temperature for use: 55-65 °C.)
- Be careful not to damage the device through excessive heat. (It is recommended to disassemble the device in an area with a temperature gauge.)
- 👉 When reheating, it should be heated no longer than 30 seconds.

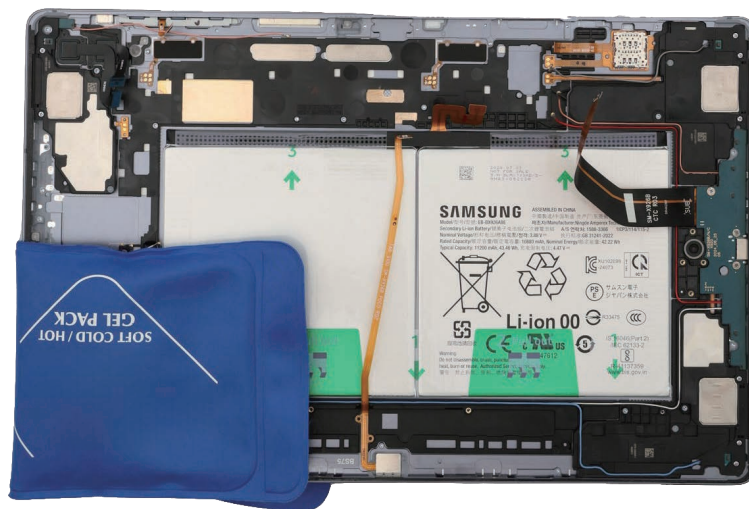

6 Using the tweezers, separate the FPCB of the speaker module carefully. For the 5G or LTE devices, separate the 2 additional coaxial cables (Blue/White). Using the tweezers, separate the coaxial cable (Black) in the speaker module. Insert the tweezers into the separator groove of the speaker and remove it from the back cover module.

⚠ Be careful not to damage the cables and near components.

- ✍ • The 2 coaxial cables (Blue/White) are only available for the 5G or LTE devices.
- The cables and connectors may vary depending on the country, region, or specifications.

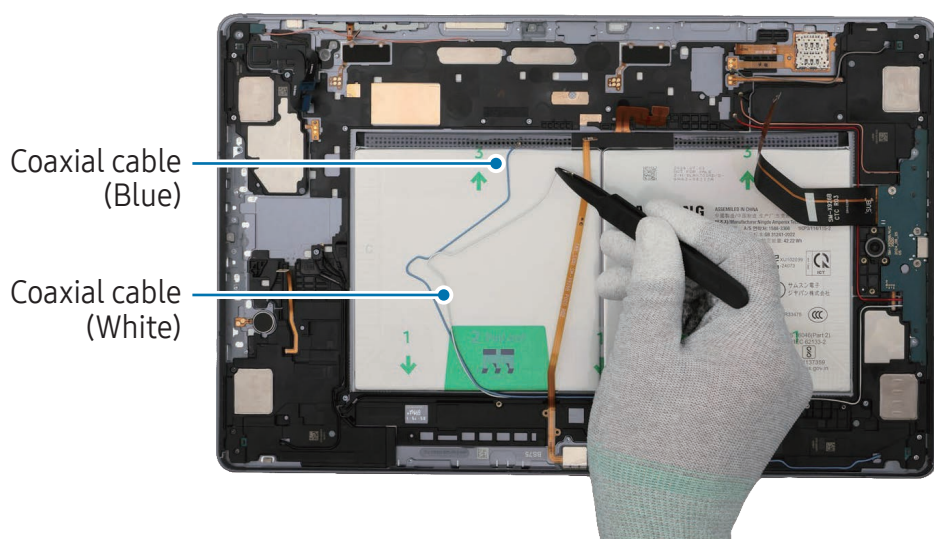
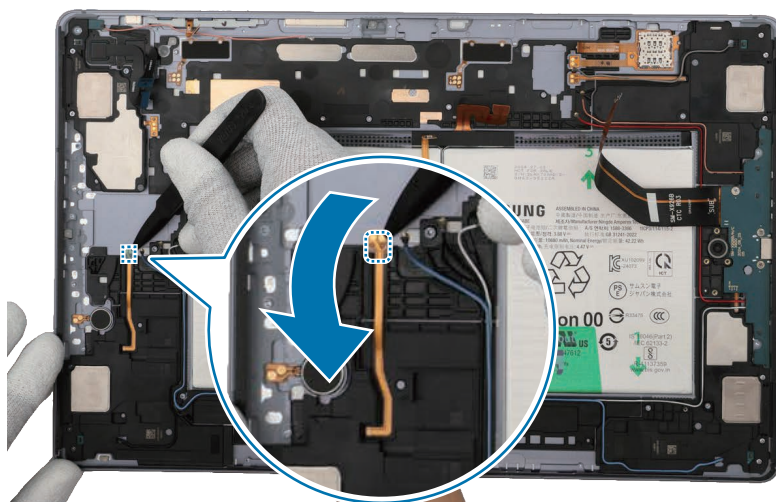

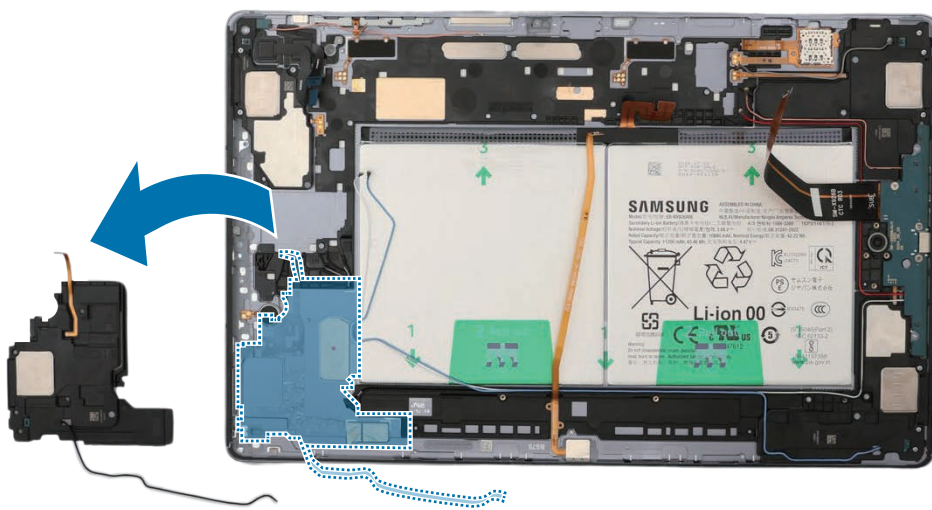
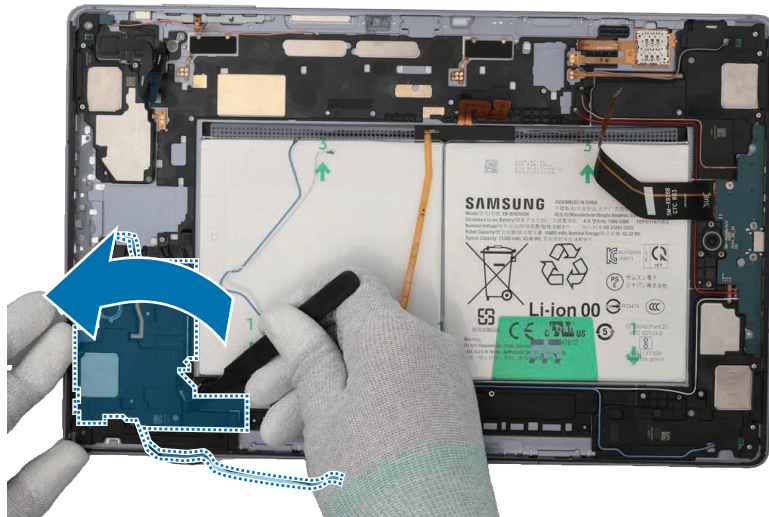
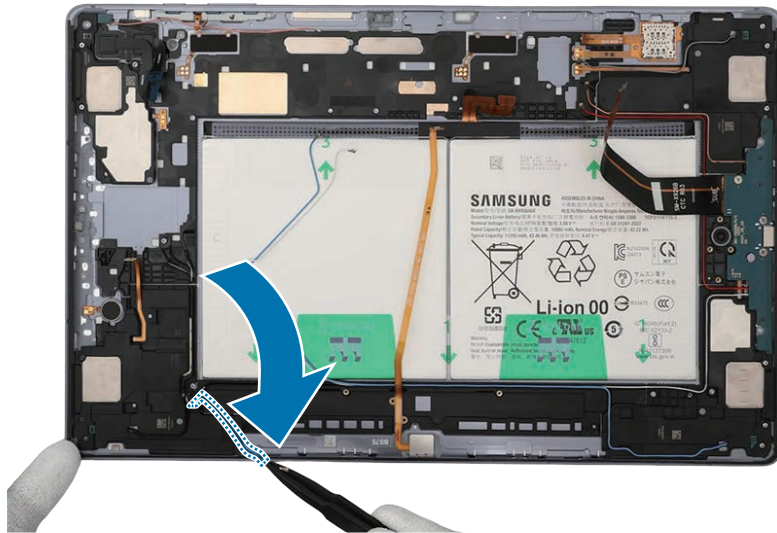

7 Using the tweezers, separate the coaxial cable connector (Black) from the speaker module.

⚠ Be careful not to damage the cable.

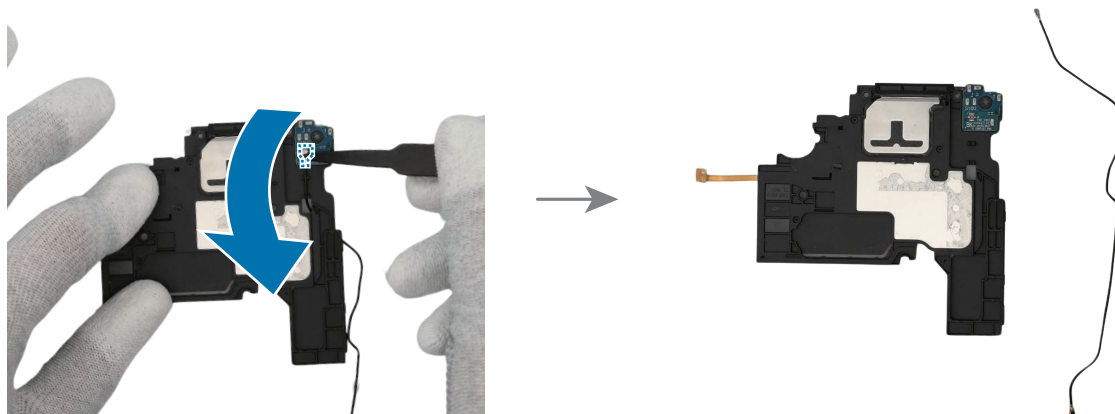

Reassembly

! Leaving screws inside the device may damage internal components, such as the battery. During assembly, be extra careful not to leave any unassembled screws inside the device.

1 Using the tweezers and your fingers, remove all adhesive tapes from where the speaker was attached.

- !** • Make sure to remove any residual tapes attached to the position of the separated speaker before reassembling the new speaker.
- Be careful not to damage the near components.

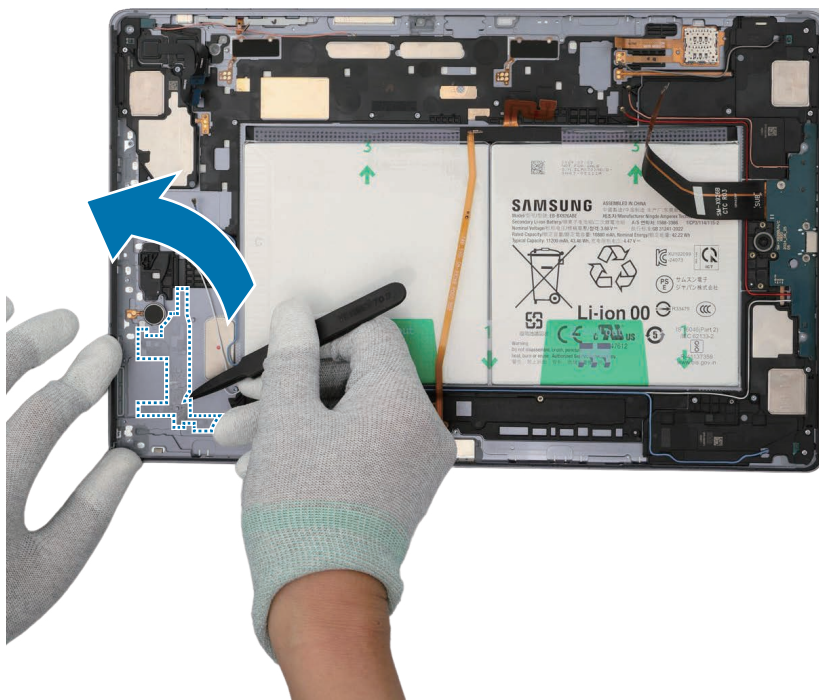

- Using the tweezers, remove the release film of a new speaker1 adhesive tape (1 ea). Align the outside shape of the tape with the speaker position and attach it accurately. Gently press down the tape with your fingers so that the tape can be attached well.

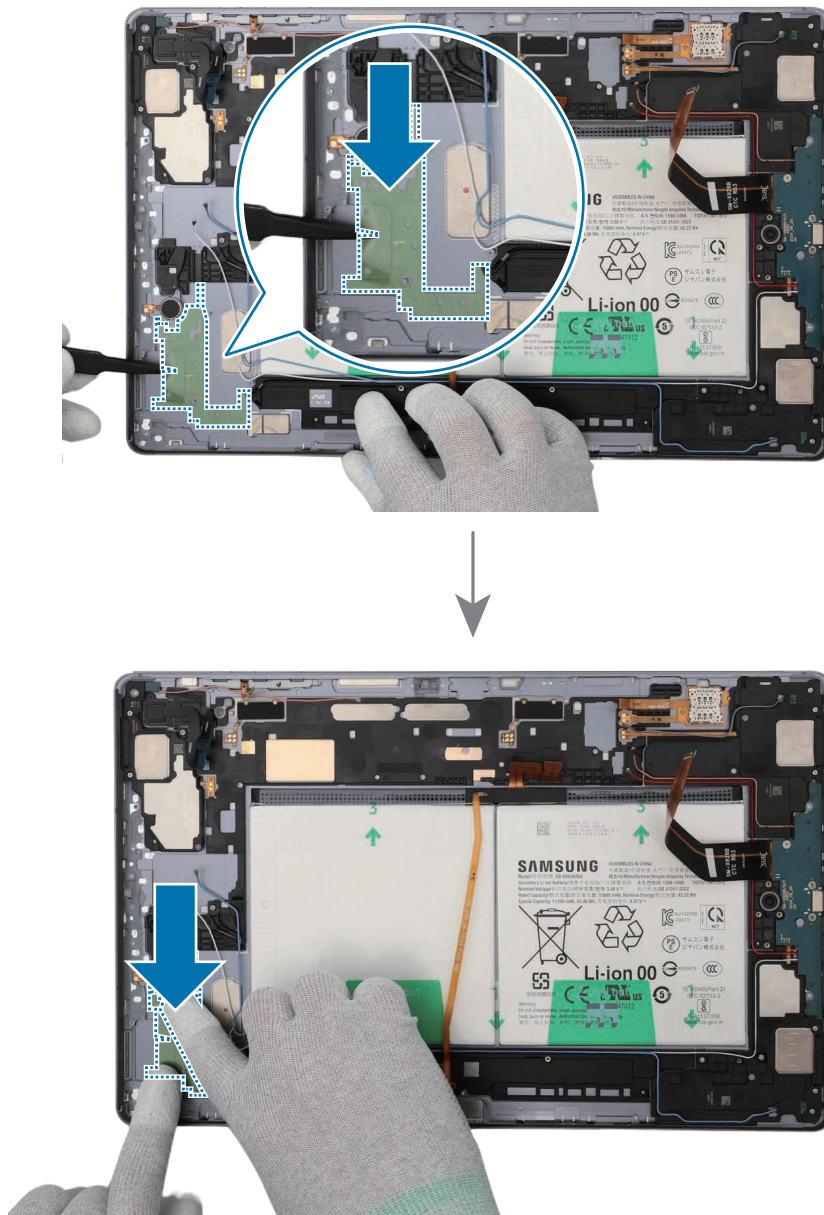

3 Using the tweezers, connect the coaxial cable connector (Black) to the new speaker module.

⚠ Be careful not to damage the speaker and cable.

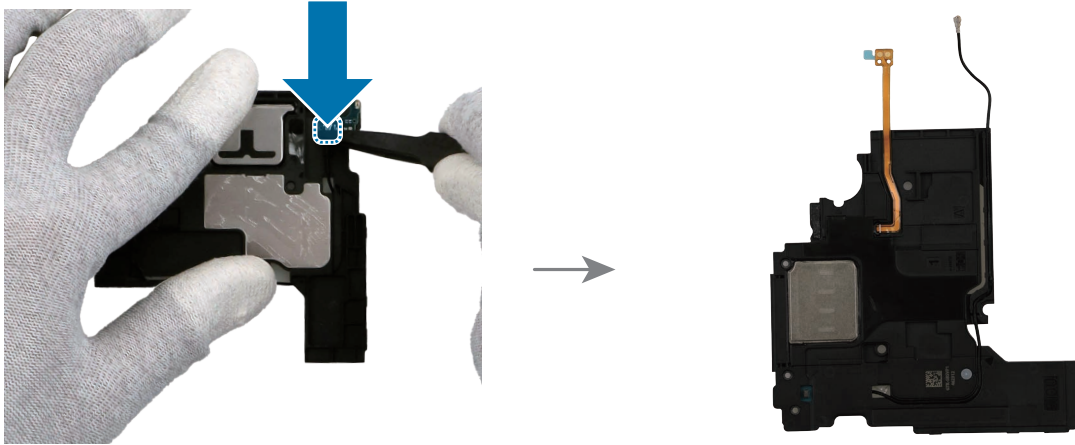

4 Using the tweezers, hold the protruding release film of the attached tape and carefully remove it.

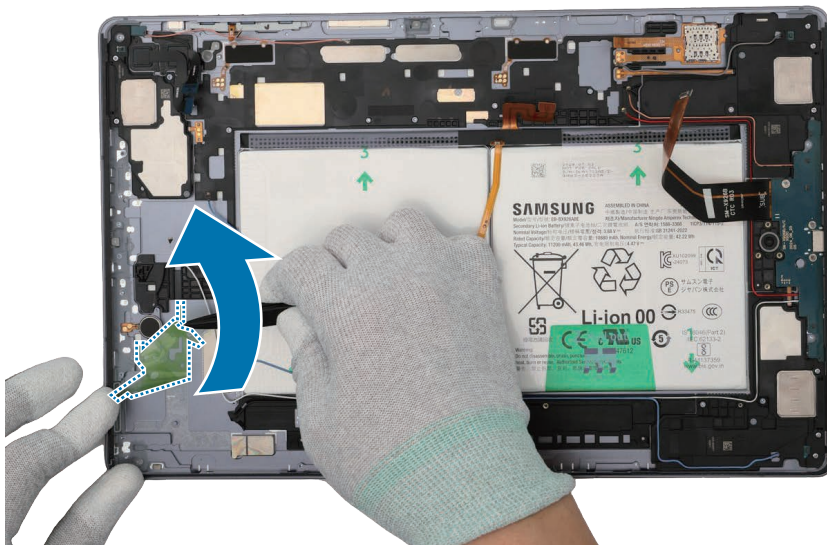

5 Using the tweezers or your fingers, remove the release film of the new speaker. Place the speaker module to the exact position, and assemble it to the back cover module.

⚠ Be careful not to damage the battery.

- ⚠ • The cables have to be positioned outside so as not to interfere when assembling the speaker.
- Be careful not to damage the speaker and cable.
- Be careful not to damage the near components.

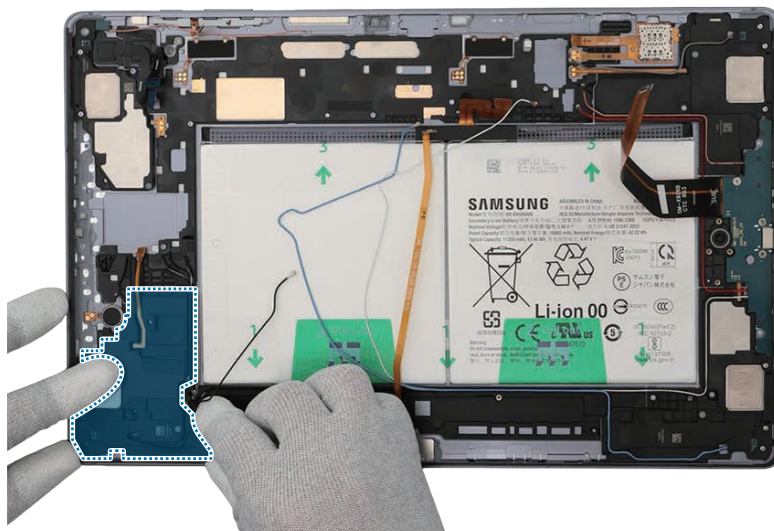
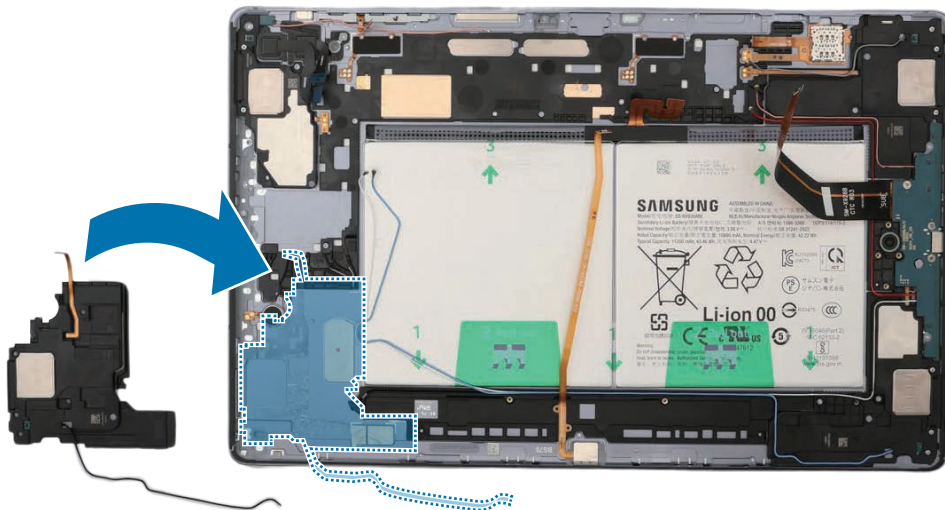
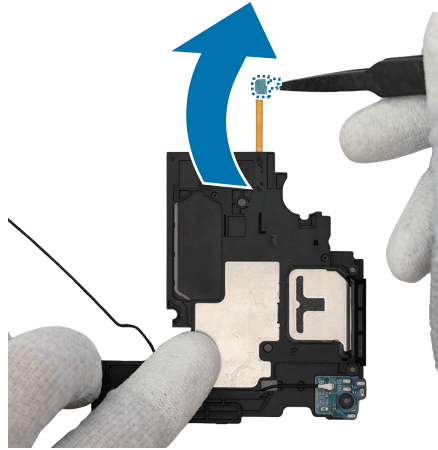

6 Using the tweezers, assemble the coaxial cable (Black) to the speaker module.

⚠ Be careful not to damage the speaker and cable.

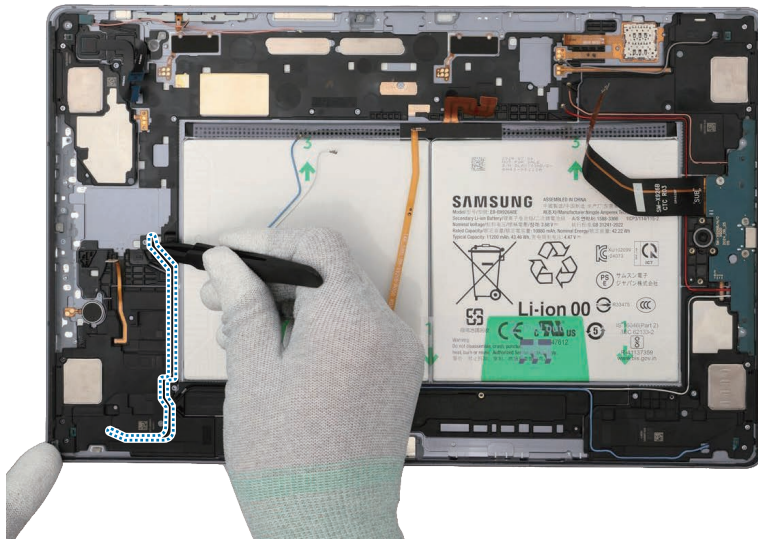

7 For the 5G or LTE devices, assemble the coaxial cables (White/Blue) to the speaker module.

⚠ Be careful not to damage the cables and near components.

- ✍ • The 2 coaxial cables (White/Blue) are only available for the 5G or LTE devices.
- The cables and connectors may vary depending on the country, region, or specifications.

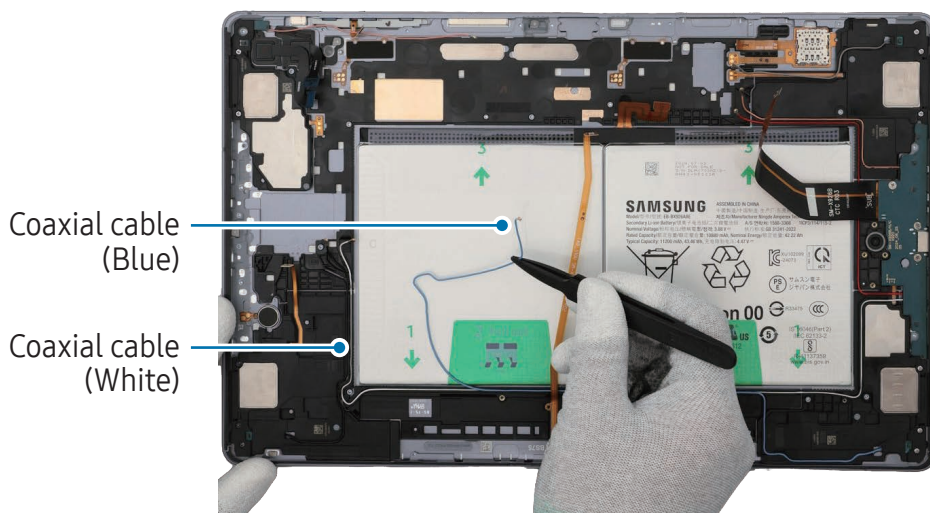

9 Using the tweezers, place the Wi-Fi board to the exact position, and assemble it to the back cover module.

⚠ Be careful not to damage the Wi-Fi board and near components.

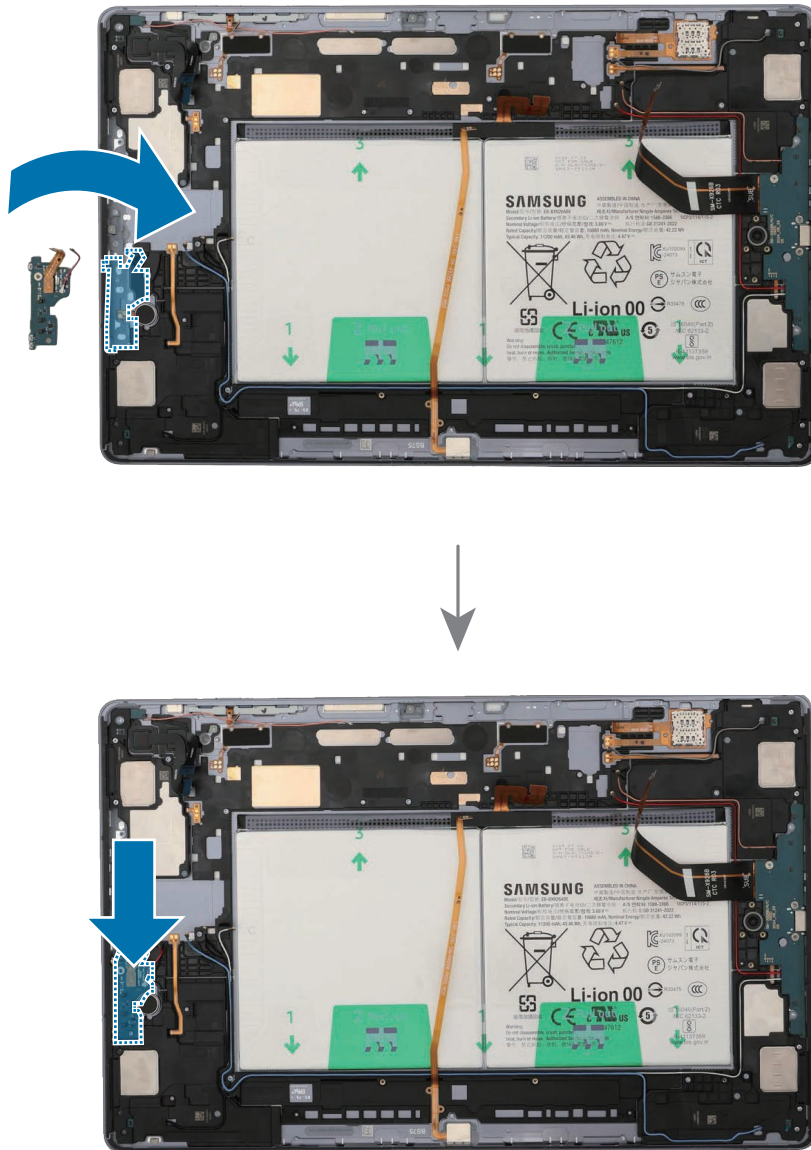

10 Place the main board to the exact position, and assemble it to the back cover module.

- ❗ • The cables have to be positioned outside so as not to interfere when assembling the main board.
- Be careful not to damage the main board and near components.

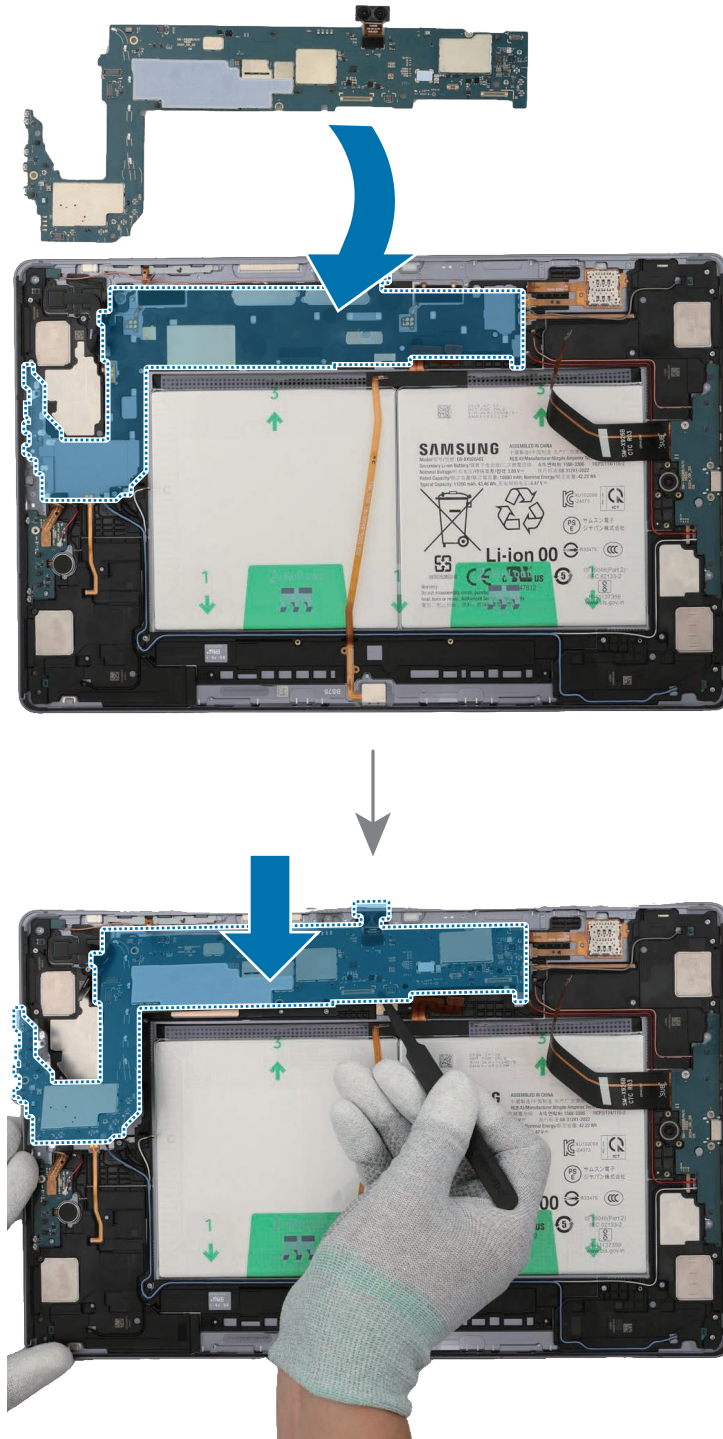

11 Using the tweezers, connect the coaxial cable (Orange) to the main board.

⚠ Be careful not to damage the cables and near components.

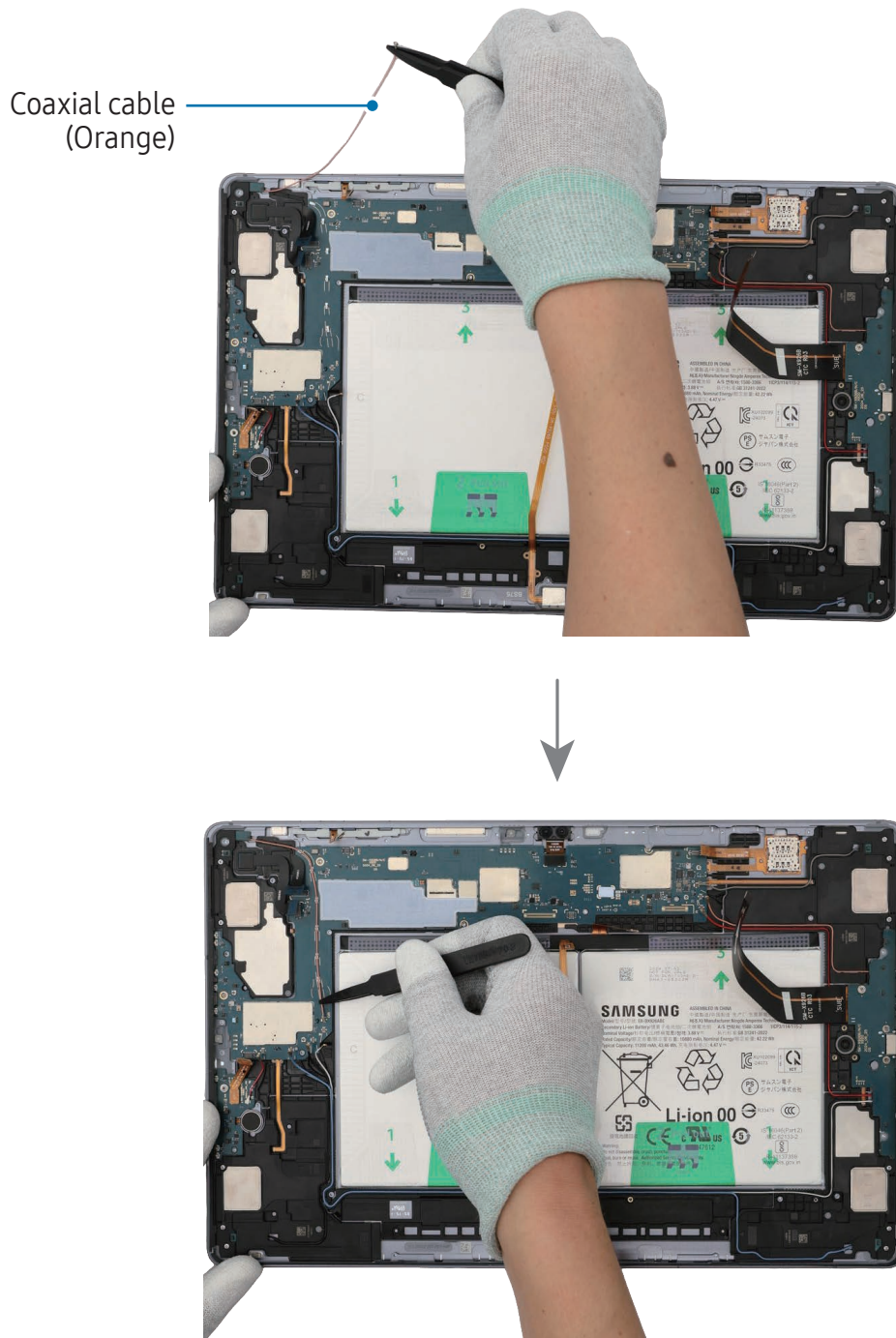

12 Check the screw 3463 (4 ea) and fasten them on the main board using a cross-head screwdriver.

⚠ Be careful not to damage the main board and near components.

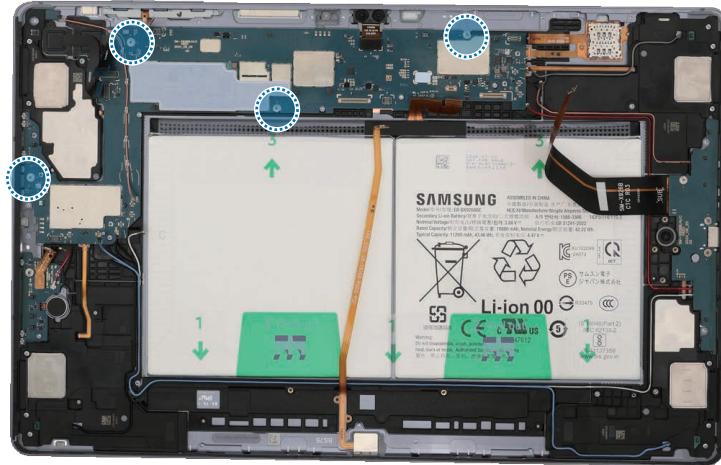

13 Check the screw 3443 (1 ea) and fasten it on the Wi-Fi board using a cross-head screwdriver.

⚠ Be careful not to damage the Wi-Fi board and near components.

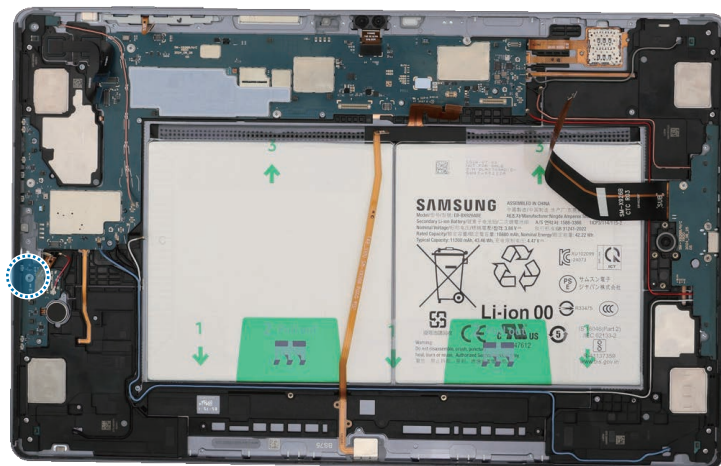

- 14 Check the screw 3405 (3 ea) and fasten them on the speaker using a cross-head screwdriver.

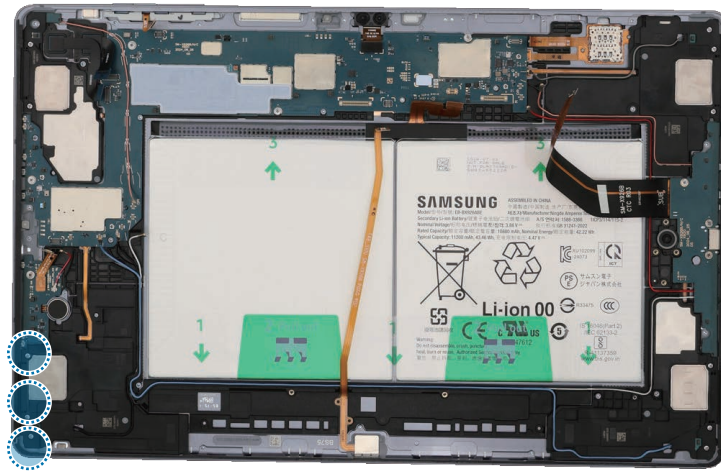

- 15 Using the tweezers, connect the 8 connectors and the 3 coaxial cable connectors (Orange/Black/Red) to the main board. For the 5G or LTE devices, connect the additional 5 coaxial cable connectors (Blue/White/Grey/Orange/Red).

- ⚠ Be careful not to damage the battery.
- ⚠ • Be careful not to damage the cable while connecting the connector.
- Be careful not to damage the near components.
- ✍ • The 5 coaxial cables (Blue/White/Grey/Orange/Red) are only available for the 5G or LTE devices.
- The cables and connectors may vary depending on the country, region, or specifications.

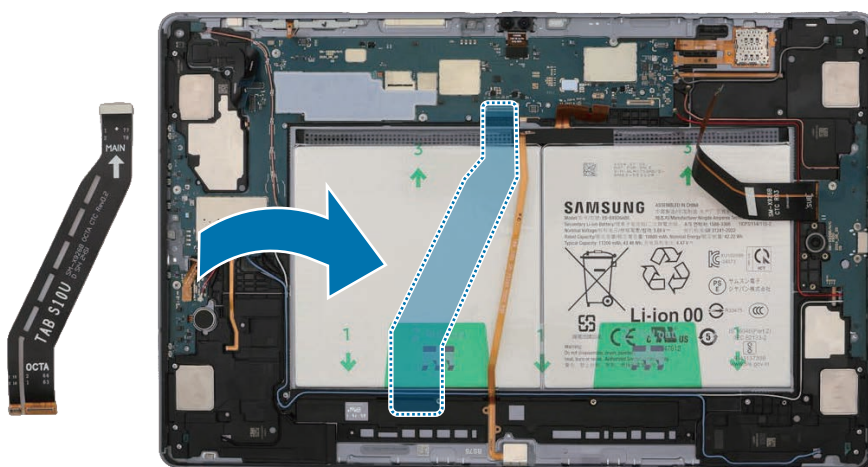

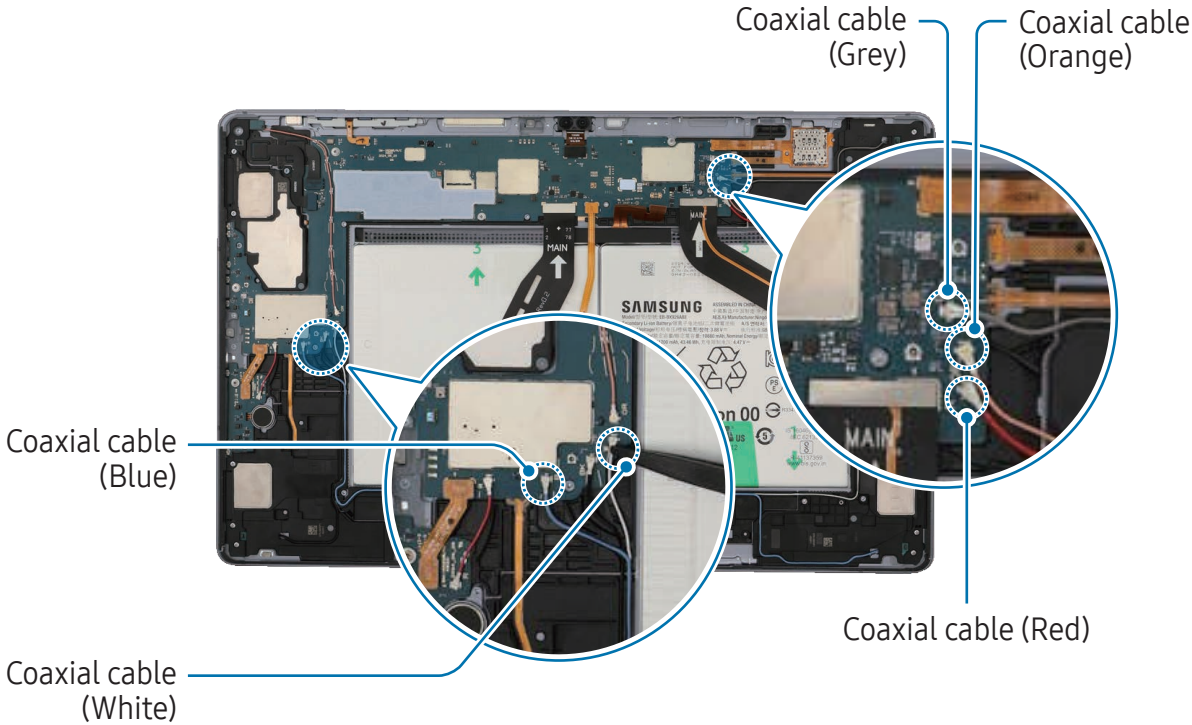
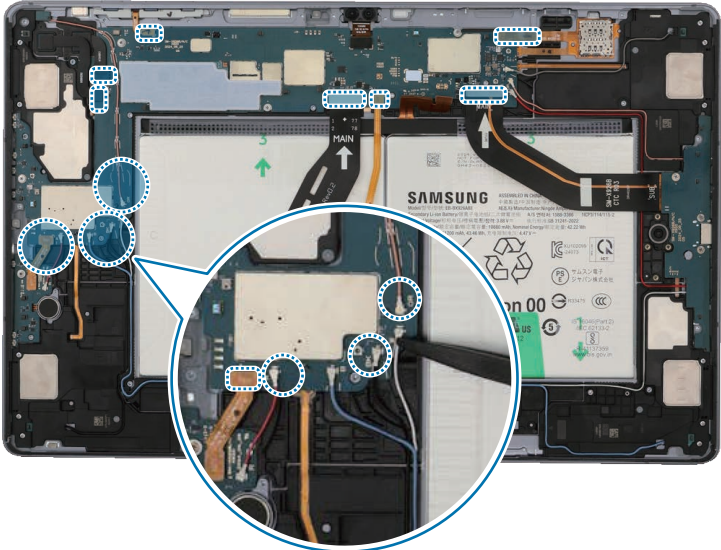

16 Connect the battery connector to the main board.

⚠ Be careful not to damage the battery.

⚠ Be careful not to damage the battery connector and near components.

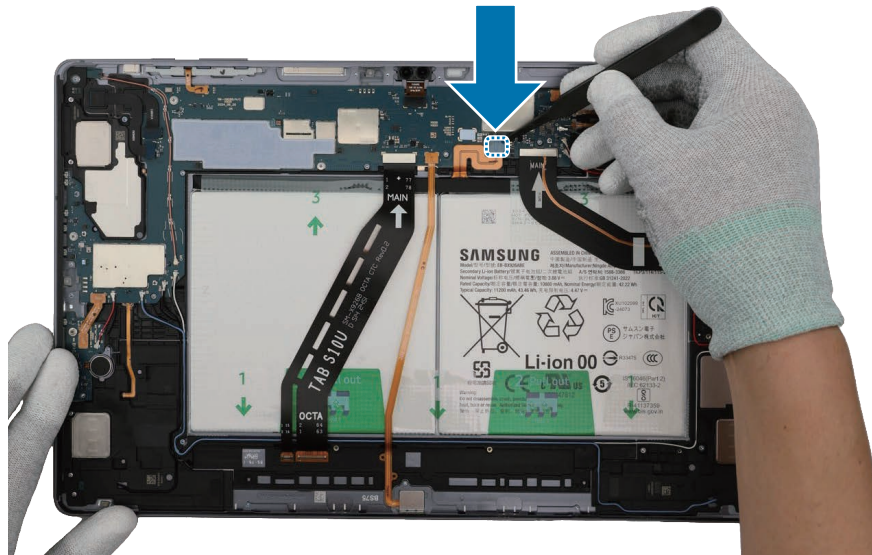

👉 Reassemble the **Bracket** and **Screen** to complete assembly.

Speaker 2

Disassembly

 Remove the [Screen](#) and [Bracket](#) first before you begin.

1 Using the tweezers, disconnect the battery connector from the main board first. Separate the 8 connectors and the 3 coaxial cable connectors (Orange/Black/Red) from the main board. For the 5G or LTE devices, separate the additional 5 coaxial cable connectors (Blue/White/Grey/Orange/Red).

 • Make sure to first disconnect the battery connector for your own safety.
• Be careful not to damage the battery.

 • Be careful not to damage the cable while removing the connector.
• Be careful not to damage the near components.

 • The 5 coaxial cables (Blue/White/Grey/Orange/Red) are only available for the 5G or LTE devices.
• The cables and connectors may vary depending on the country, region, or specifications.

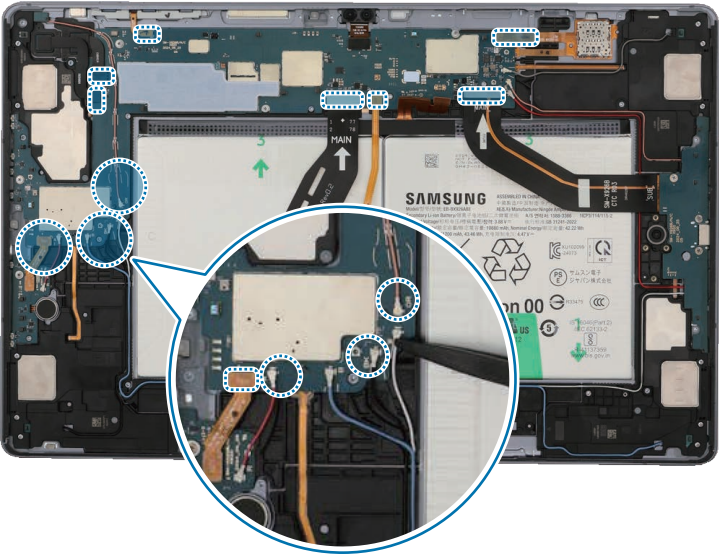
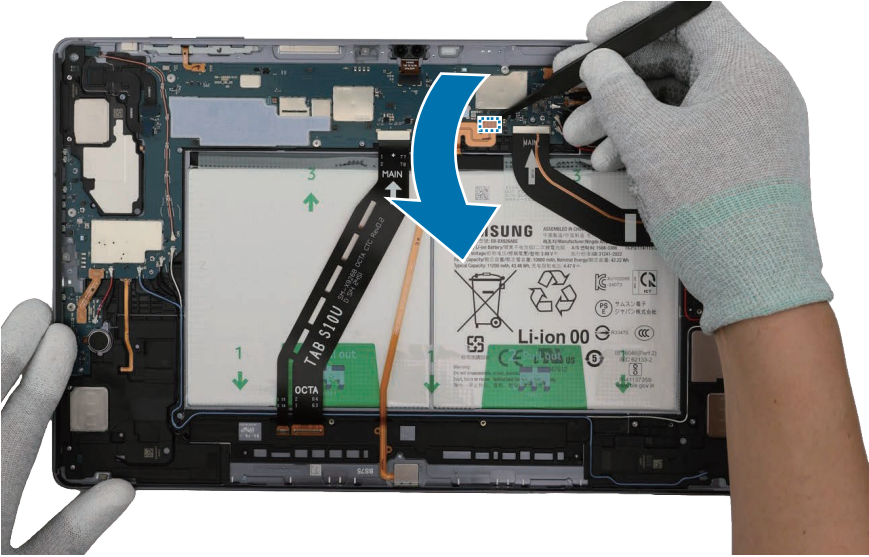

Disassembly and Assembly

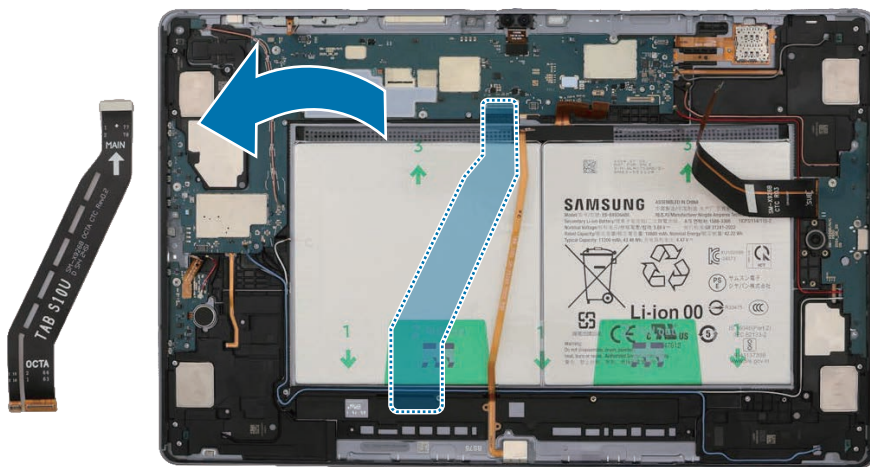
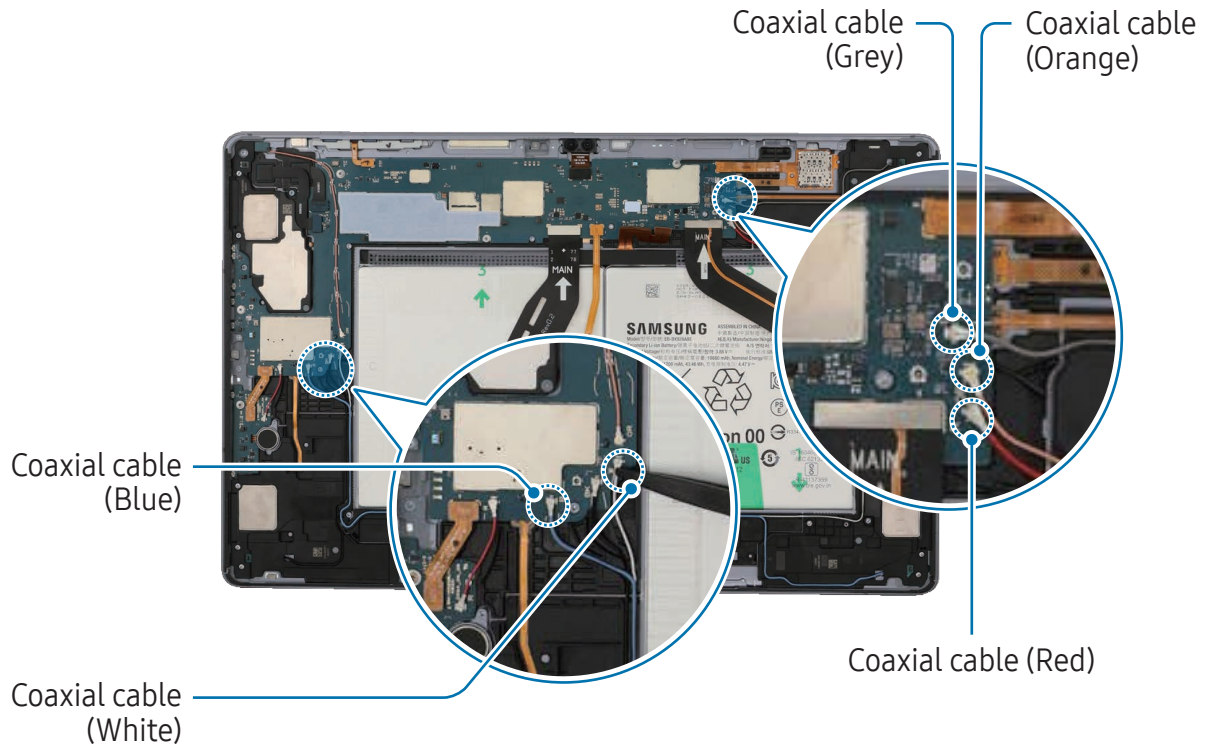

2 Check the 4 screws on the main board and the 2 screws on the speaker. Remove all 6 screws using a cross-head screwdriver.

⚠ Be careful not to damage the main board and near components.

✓ Check the number of screws that have been removed, and store them carefully to make sure that no unassembled screws are left inside the device during assembly.

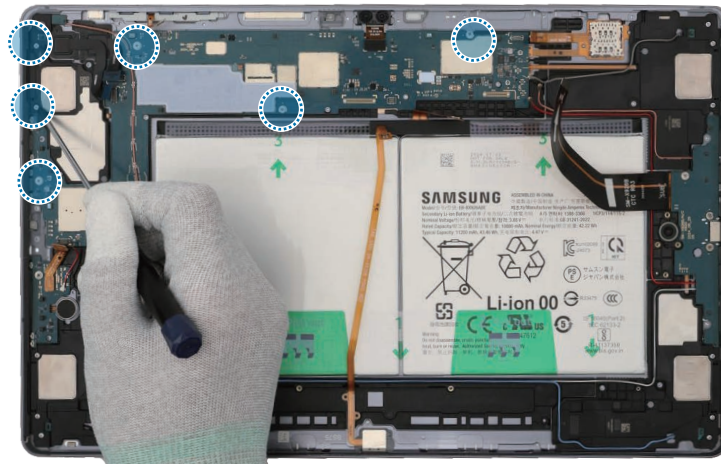

3 Using the tweezers, disconnect the coaxial cable (Orange) from the main board. Then, lift up on the separator groove of the main board and remove the main board module.

- ⚠ • Be careful not to damage the battery connector, the main board, and near components.
- The cables have to be positioned outside so as not to interfere when disassembling the main board.

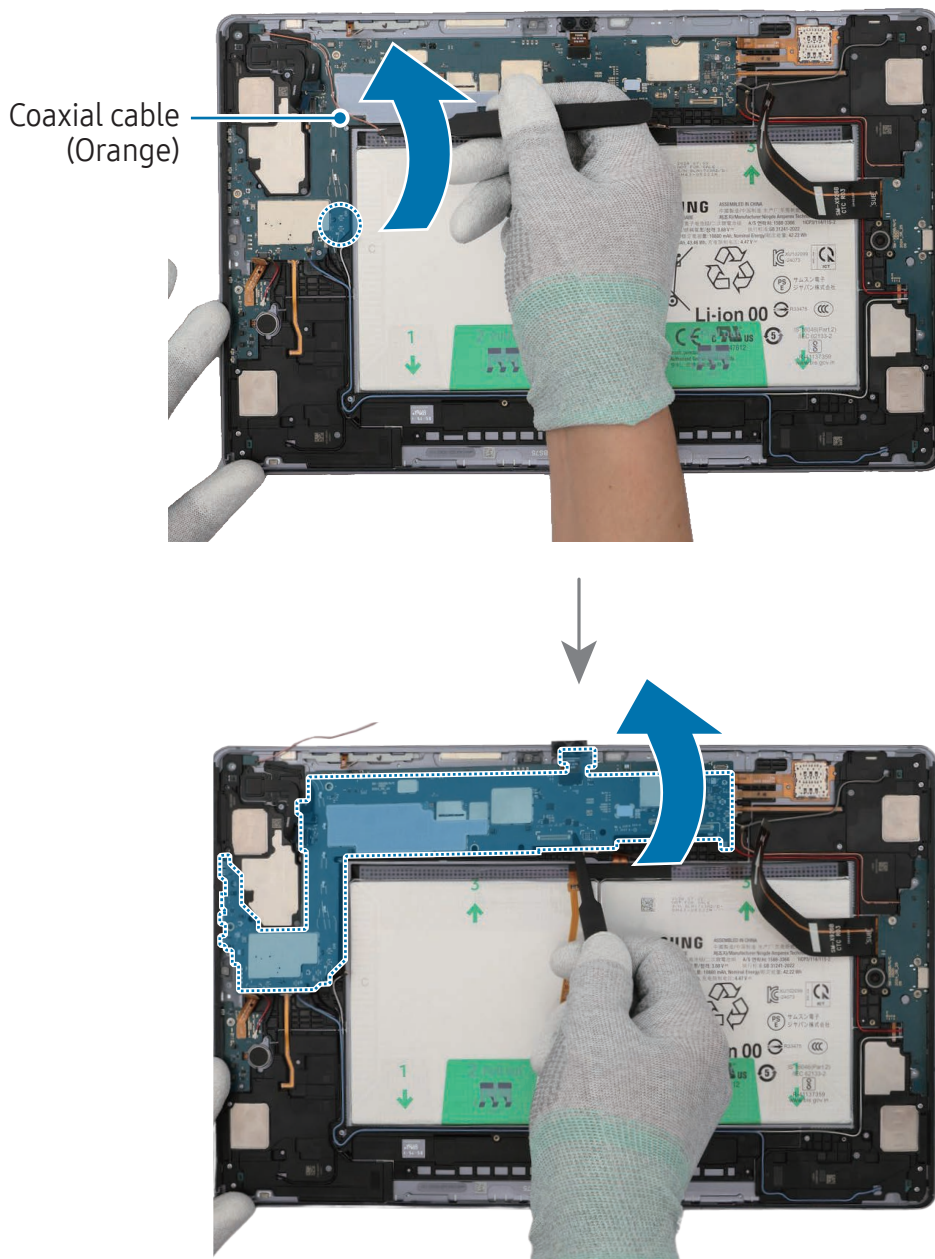

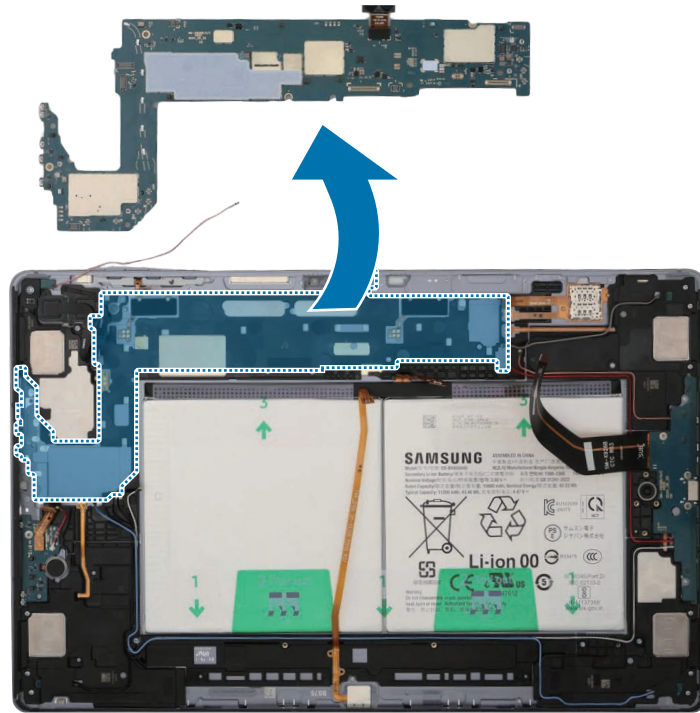

4 Heat the microwaveable heating bag and apply it to the both front and back side of the speaker module for 4 minutes.

- ⚠ • It is possible for the device or battery to be damaged by heat.
- Do not heat the device in a microwave. Doing so could cause an explosion.
- ⚠ • Follow the heating bag's instructions for heating. The recommended time for heating the bag is 50 seconds in a 1000 W microwave and 70 seconds in a 700 W microwave. (Correct temperature for use: 55-65 °C.)
- Be careful not to damage the device through excessive heat. (It is recommended to disassemble the device in an area with a temperature gauge.)
- 👉 When reheating, it should be heated no longer than 30 seconds.

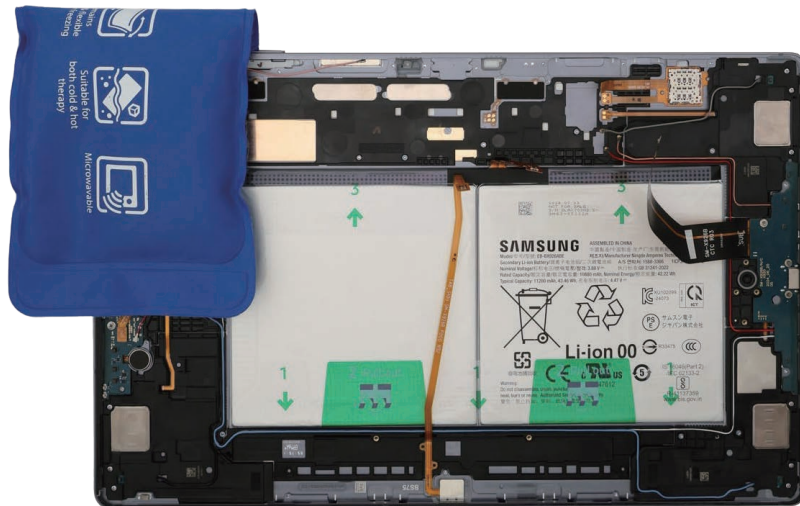

5 Using the tweezers, separate the FPCB of the speaker module carefully. Insert the tweezers into the separator groove of the speaker and remove it from the back cover module.

- ⚠ Be careful not to damage the cables and near components.

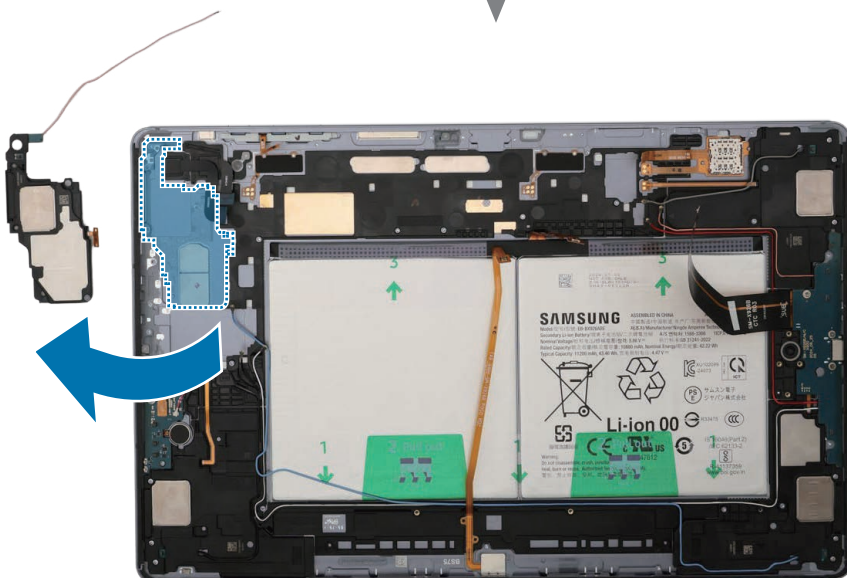
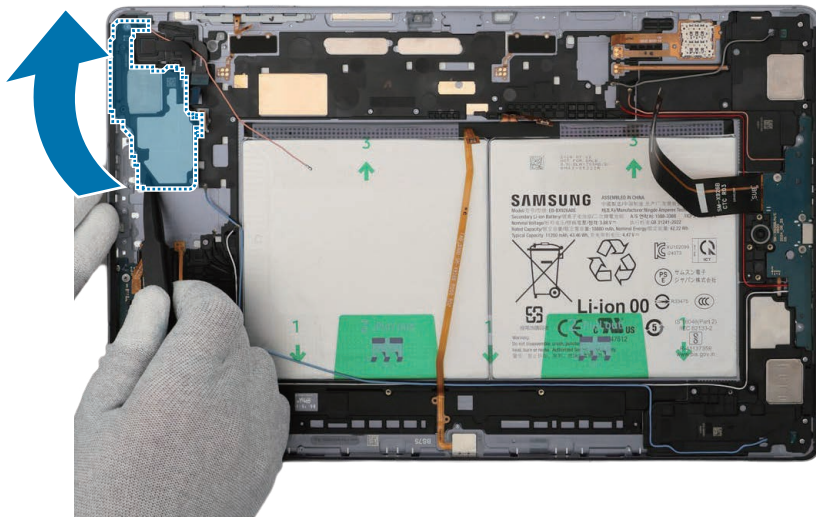
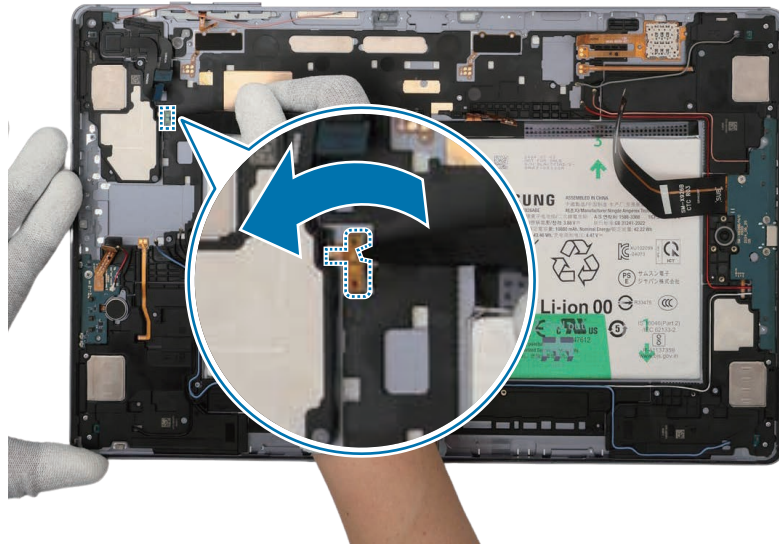

6 Using the tweezers, separate the coaxial cable connector (Orange) from the speaker module.

⚠ Be careful not to damage the cable.

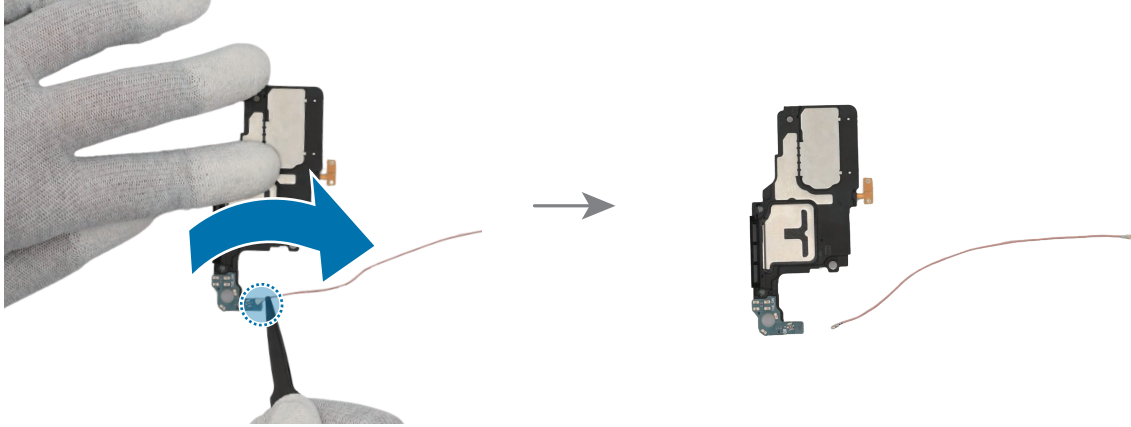

Reassembly

 Leaving screws inside the device may damage internal components, such as the battery. During assembly, be extra careful not to leave any unassembled screws inside the device.

1 Using the tweezers and your fingers, remove all adhesive tapes from where the speaker was attached.

-  • Make sure to remove any residual tapes attached to the position of the separated speaker before reassembling the new speaker.
- Be careful not to damage the near components.

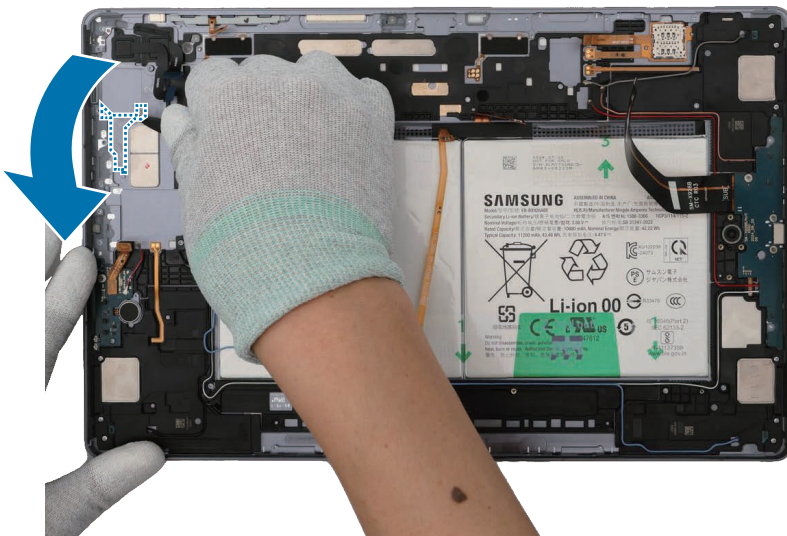

- 2 Remove the clear film of a new speaker 2 adhesive tape and apply it to the bottom of the new speaker 2. Gently press down the tape with your fingers so that the tape can be attached well.

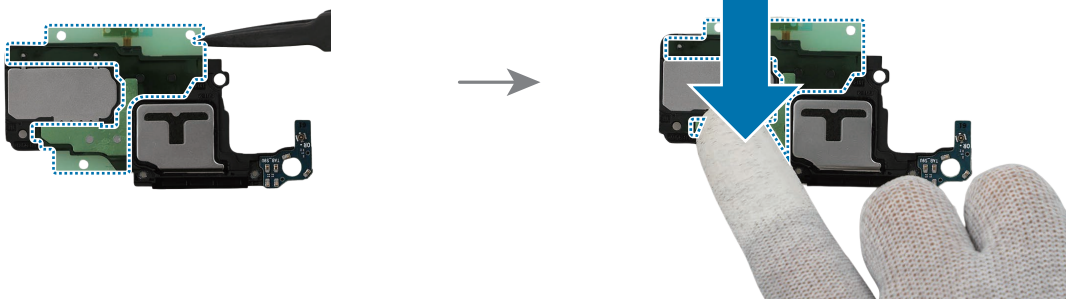



- 3 Using the tweezers, connect the coaxial cable connector (Orange) to the new speaker module.

 Be careful not to damage the speaker and cable.



4 Using the tweezers or your fingers, remove all release films of the new speaker. Place the speaker module to the exact position, and assemble it to the back cover module.

 Be careful not to damage the battery.

-  • The cables have to be positioned outside so as not to interfere when assembling the speaker.
- Be careful not to damage the speaker and cable.
- Be careful not to damage the near components.

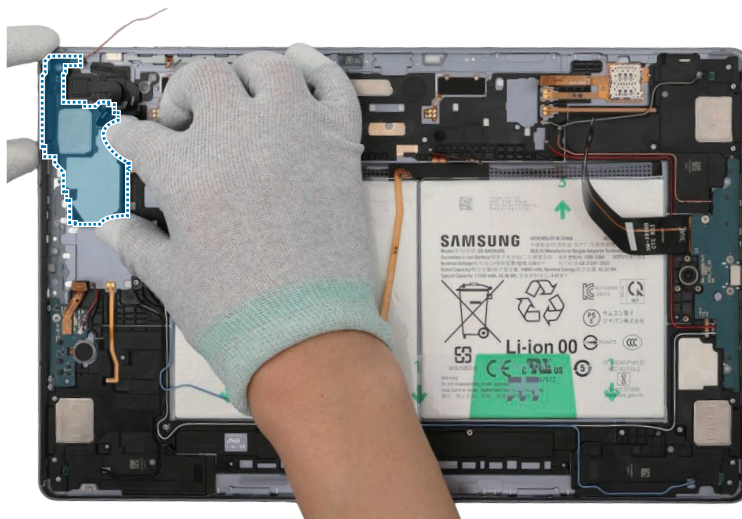
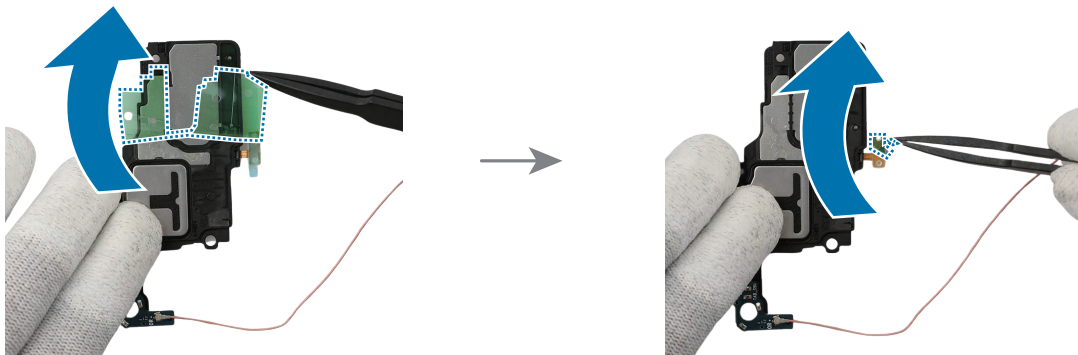

5 Using your fingers, press down softly and evenly on the speaker module and the FPCB so that the speaker module can be completely attached.

⚠ Be careful not to damage the speaker and FPCB.

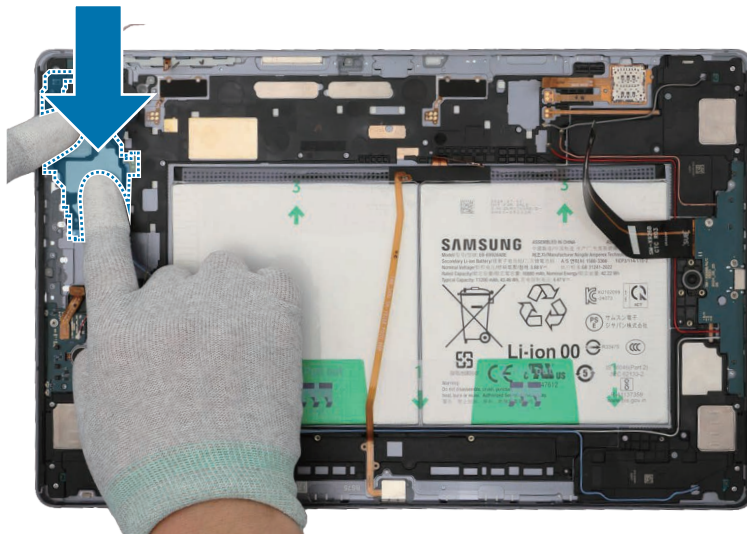

6 Place the main board to the exact position, and assemble it to the back cover module.

- ❗ • The cables have to be positioned outside so as not to interfere when assembling the main board.
- Be careful not to damage the main board and near components.

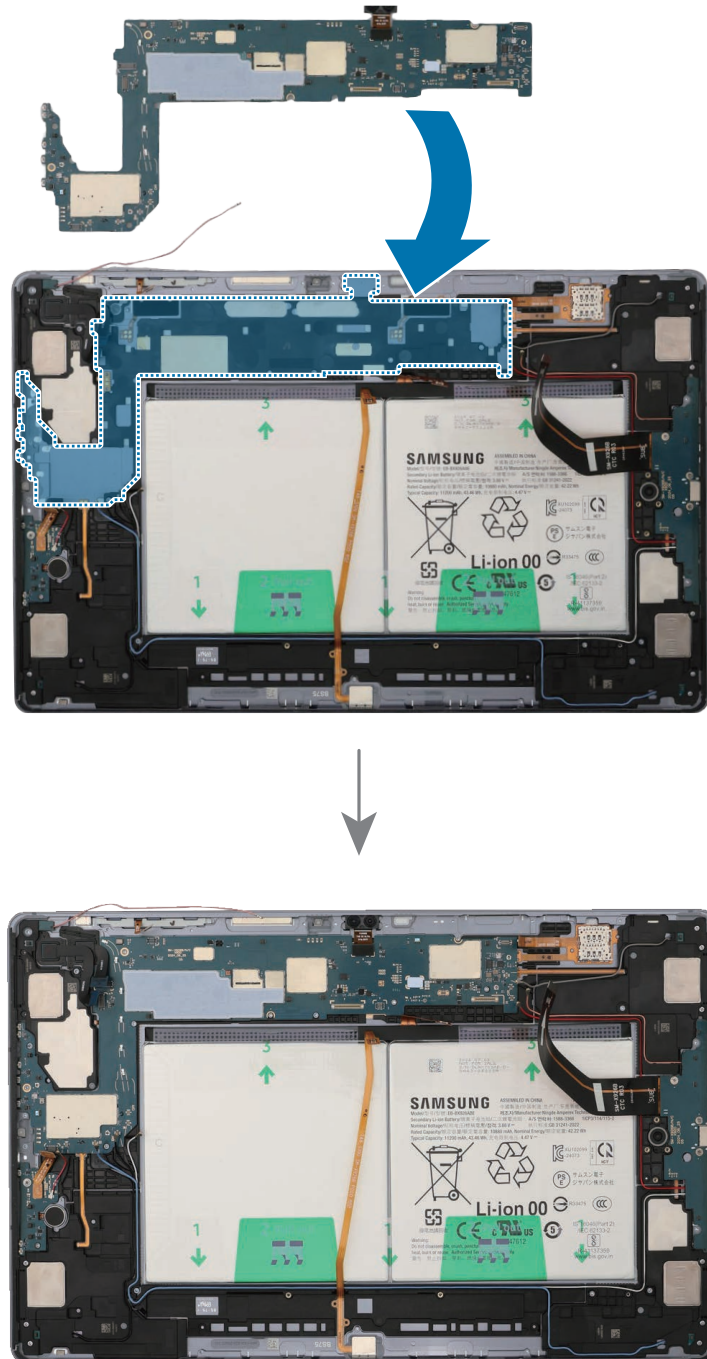

7 Using the tweezers, connect the coaxial cable (Orange) to the main board.

⚠ Be careful not to damage the cables and near components.



8 Check the screw 3463 (4 ea) and fasten them on the main board using a cross-head screwdriver.

⚠ Be careful not to damage the main board and near components.

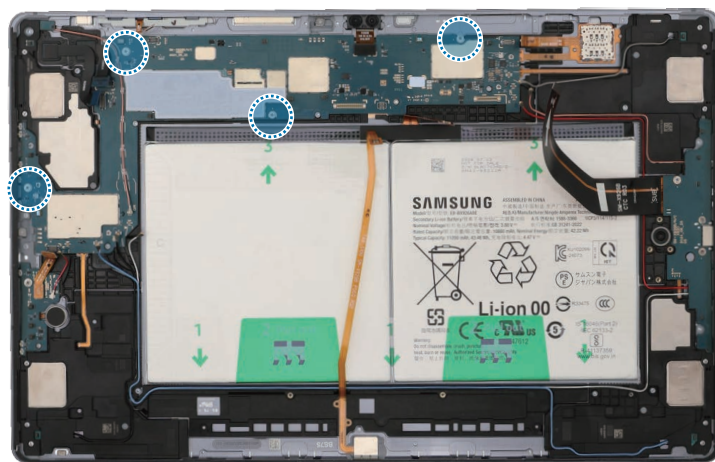

- 9 Check the screw 3405 (2 ea) and fasten them on the speaker using a cross-head screwdriver.

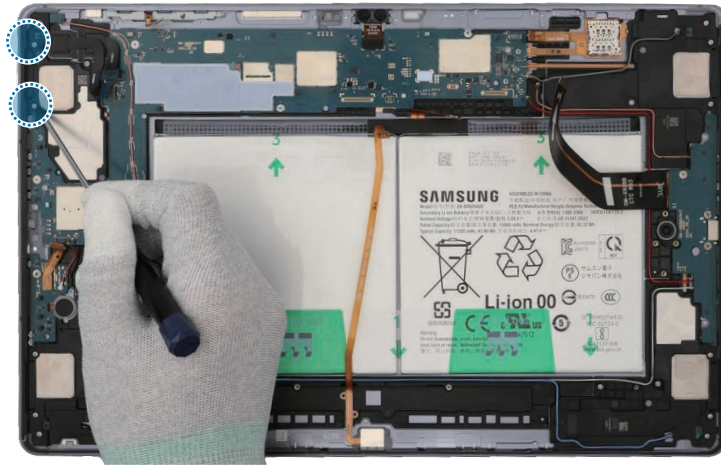

- 10 Using the tweezers, connect the 8 connectors and the 3 coaxial cable connectors (Orange/Black/Red) to the main board. For the 5G or LTE devices, connect the additional 5 coaxial cable connectors (Blue/White/Grey/Orange/Red).

- ⚠ Be careful not to damage the battery.
- ⚠ • Be careful not to damage the cable while connecting the connector.
- Be careful not to damage the near components.
- ✍ • The 5 coaxial cables (Blue/White/Grey/Orange/Red) are only available for the 5G or LTE devices.
- The cables and connectors may vary depending on the country, region, or specifications.

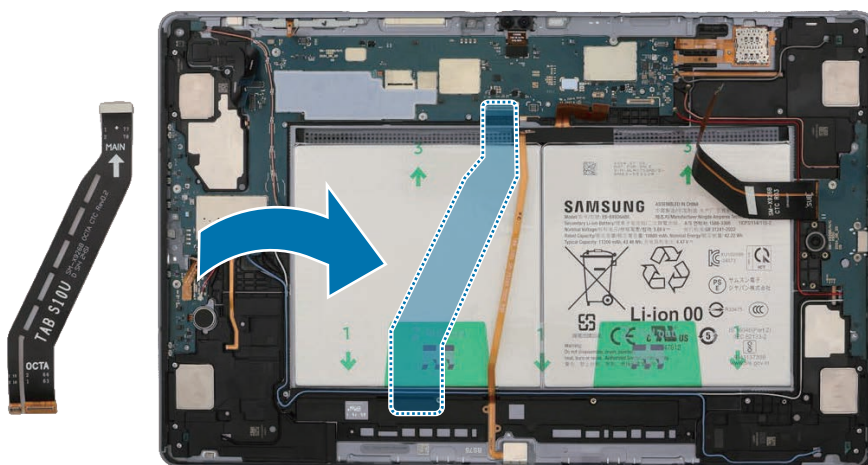

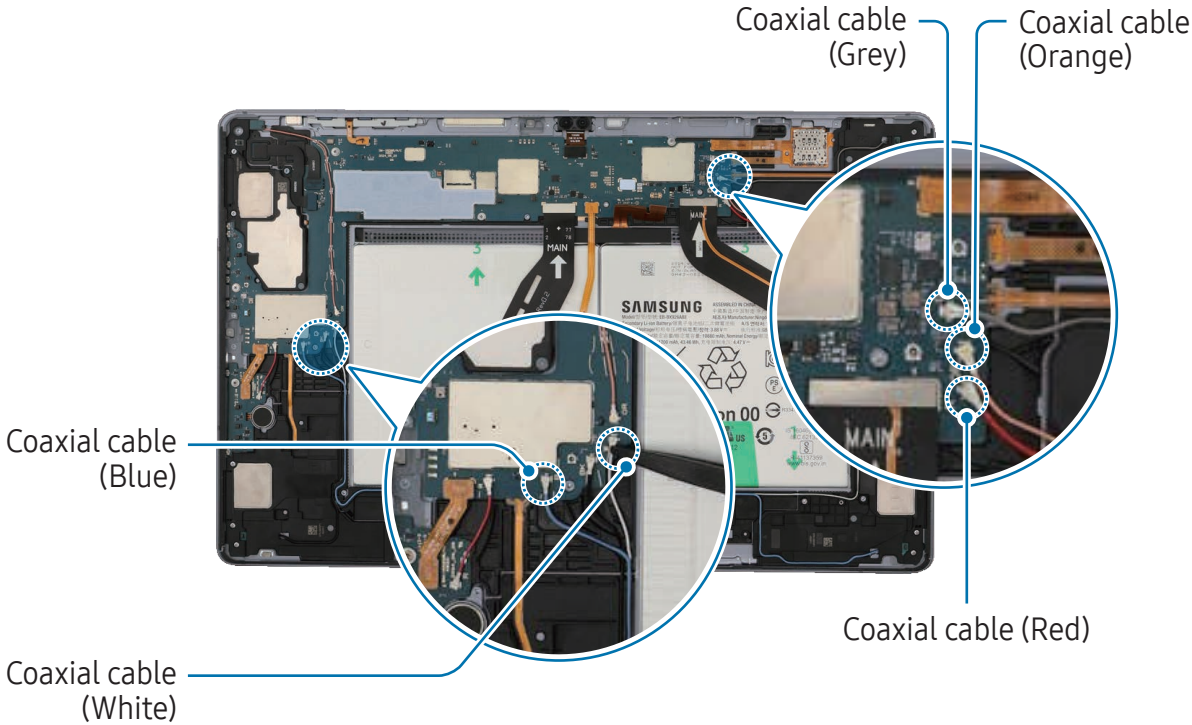
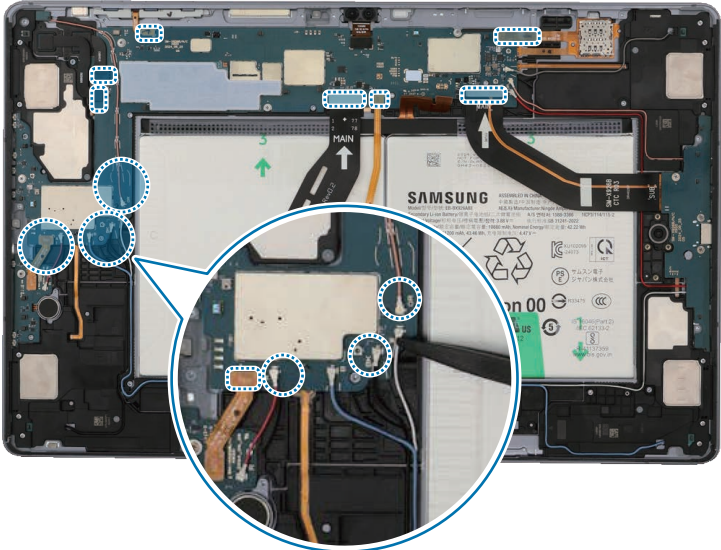

11 Connect the battery connector to the main board.

⚠ Be careful not to damage the battery.

⚠ Be careful not to damage the battery connector and near components.

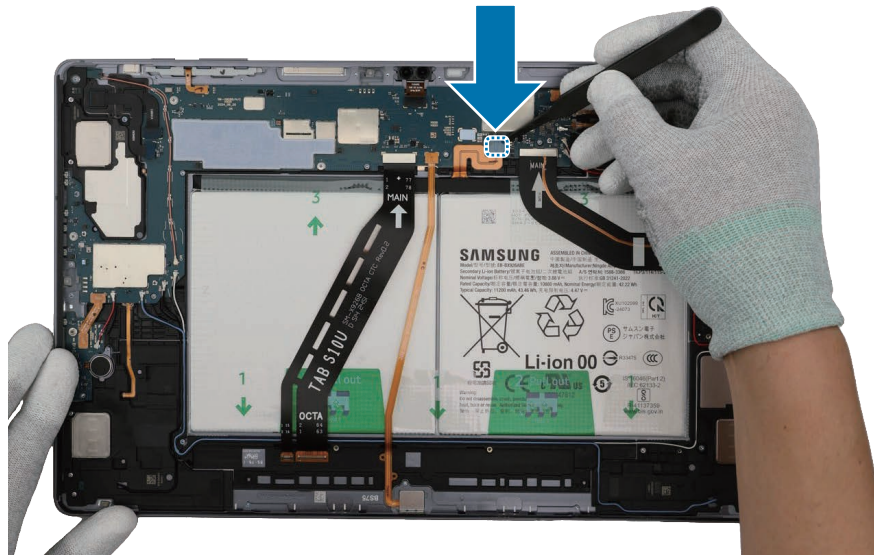

👉 Reassemble the **Bracket** and **Screen** to complete assembly.

Speaker 3

Disassembly



Remove the [Screen](#) and [Bracket](#) first before you begin.

1 Using the tweezers, disconnect the battery connector from the main board first. Separate the 8 connectors and the 3 coaxial cable connectors (Orange/Black/Red) from the main board. For the 5G or LTE devices, separate the additional 5 coaxial cable connectors (Blue/White/Grey/Orange/Red).



- Make sure to first disconnect the battery connector for your own safety.
- Be careful not to damage the battery.



- Be careful not to damage the cable while removing the connector.
- Be careful not to damage the near components.



- The 5 coaxial cables (Blue/White/Grey/Orange/Red) are only available for the 5G or LTE devices.
- The cables and connectors may vary depending on the country, region, or specifications.

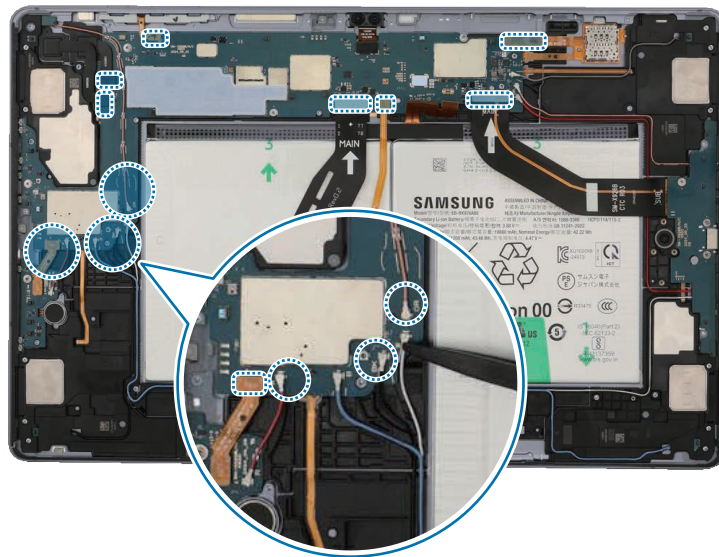
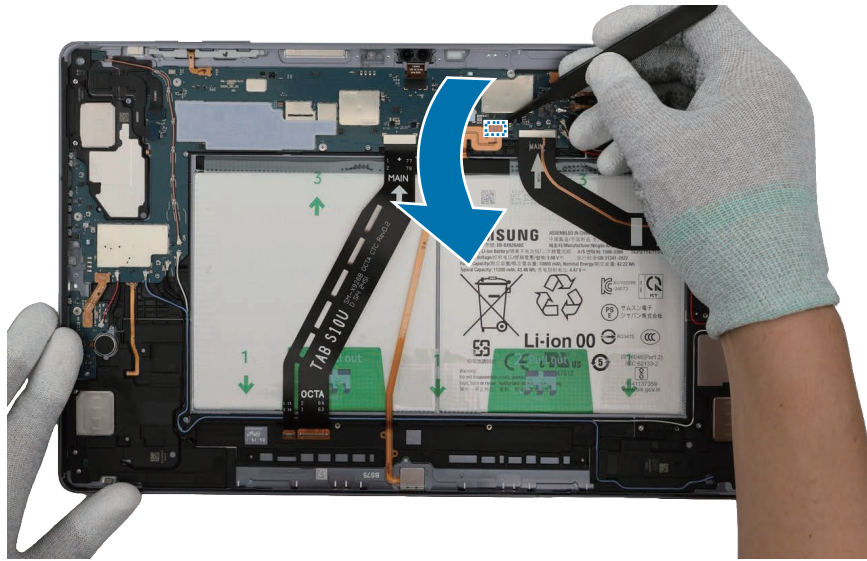

Disassembly and Assembly

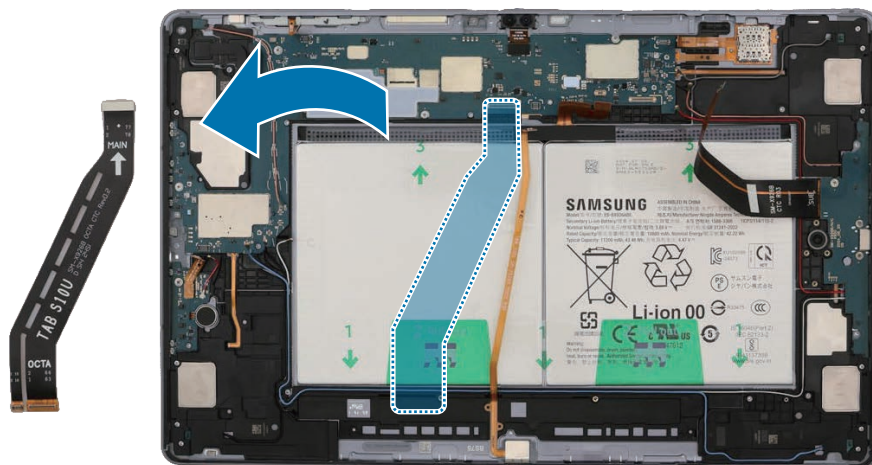
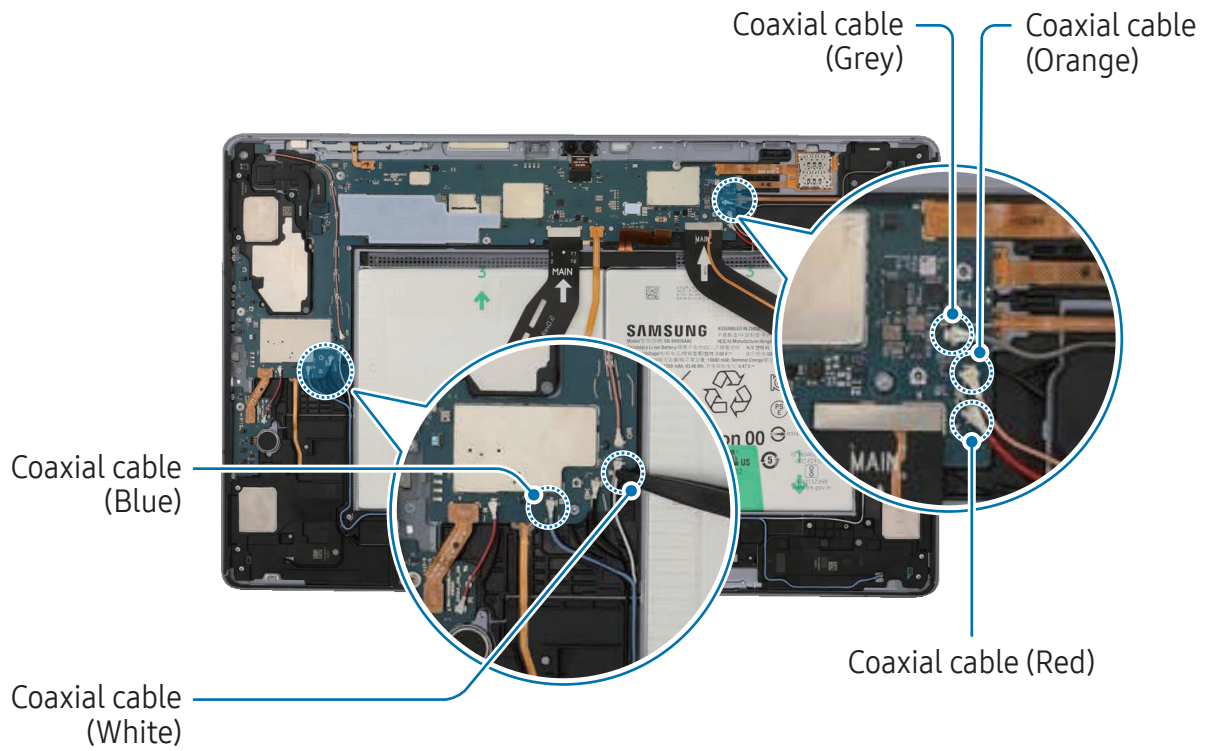

2 Check and remove the 4 screws on the main board using a cross-head screwdriver.

⚠ Be careful not to damage the main board and near components.

📝 Check the number of screws that have been removed, and store them carefully to make sure that no unassembled screws are left inside the device during assembly.

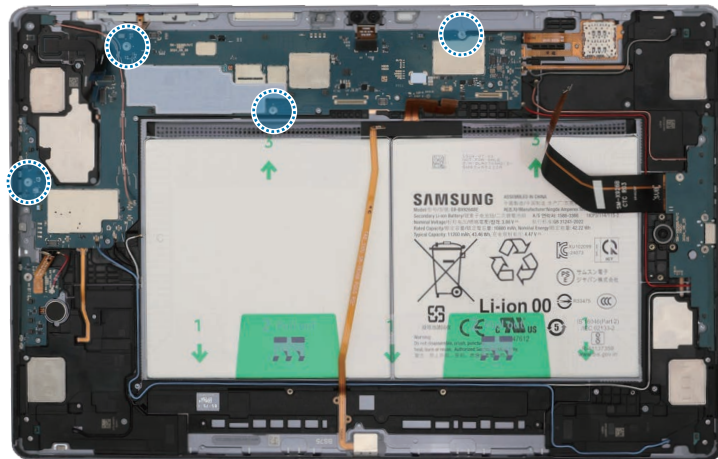

3 Using the tweezers, disconnect the coaxial cable (Orange) from the main board. Then, lift up on the separator groove of the main board and remove the main board module.

- ⚠ Be careful not to damage the battery connector, the main board, and near components.
- The cables have to be positioned outside so as not to interfere when disassembling the main board.

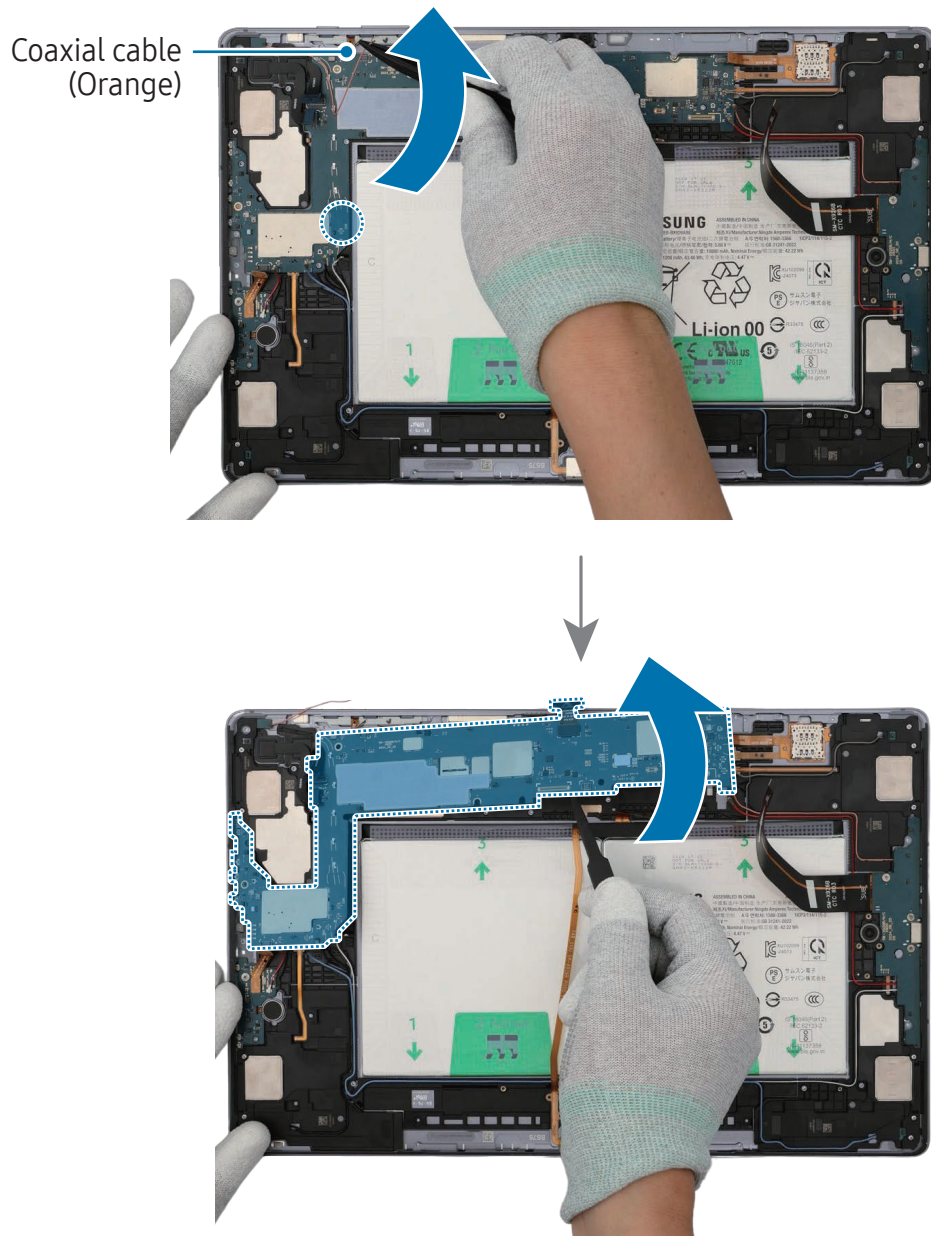

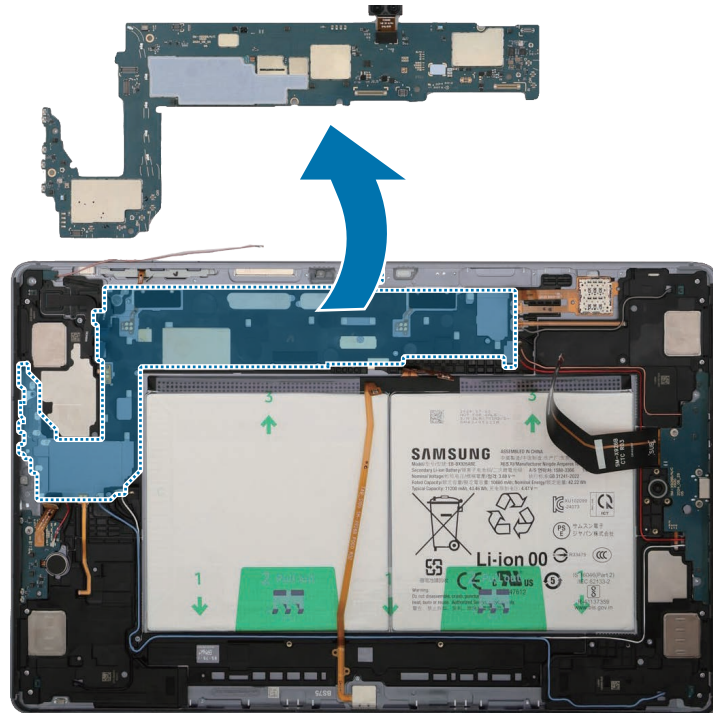

4 Check the 3 screws on the speaker and the 3 screws on the charging port. Remove all 6 screws using a cross-head screwdriver.





Be careful not to damage the charging port and near components.

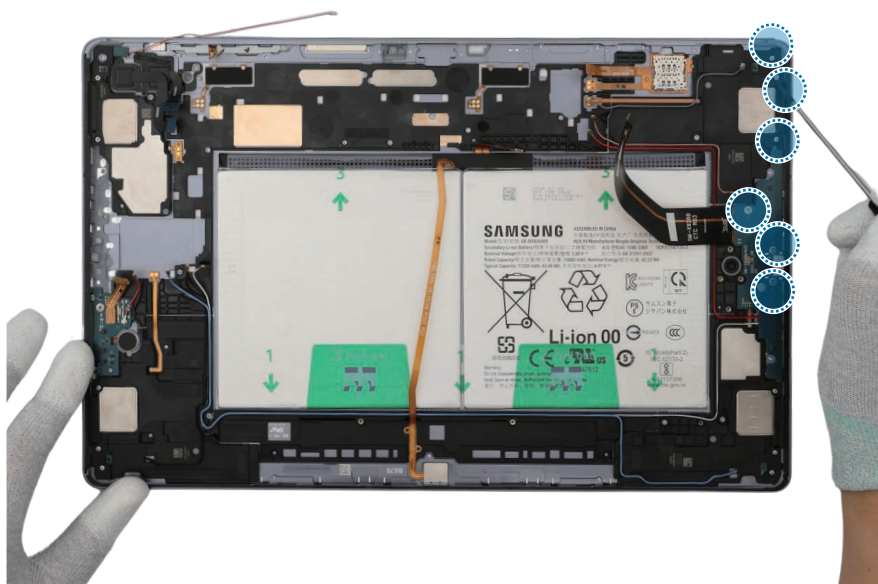

Check the number of screws that have been removed, and store them carefully to make sure that no unassembled screws are left inside the device during assembly.



- 5 For the 5G or LTE devices, disconnect the 4 coaxial cables (Blue/White/Orange/Red) in the speaker modules with the tweezers. Using the tweezers, lift up on the separator groove of the charging port module, and remove it carefully.
-  • Check the position of the overlapping cables and disconnect them in order from the top.
 - Be careful not to damage the cables and near components.
 -  • The 4 coaxial cables (Blue/White/Orange/Red) are only available for the 5G or LTE devices.
 - The cables and connectors may vary depending on the country, region, or specifications.

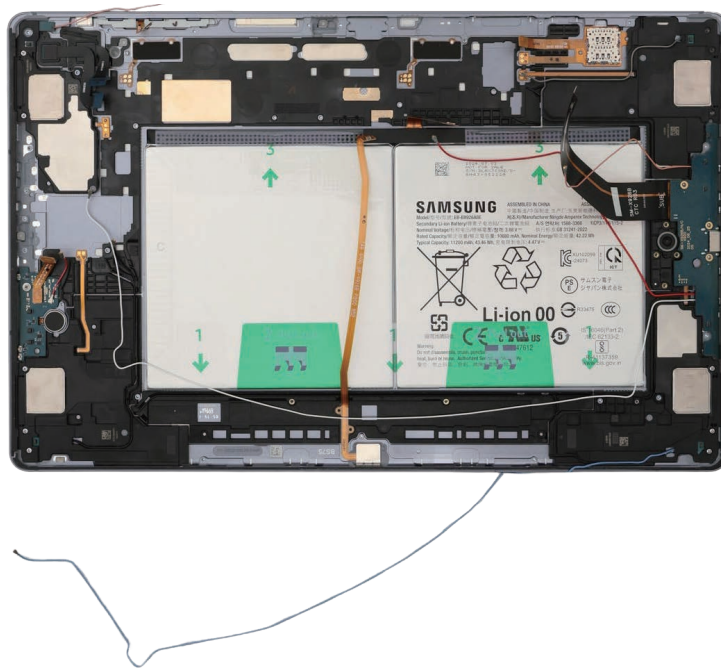
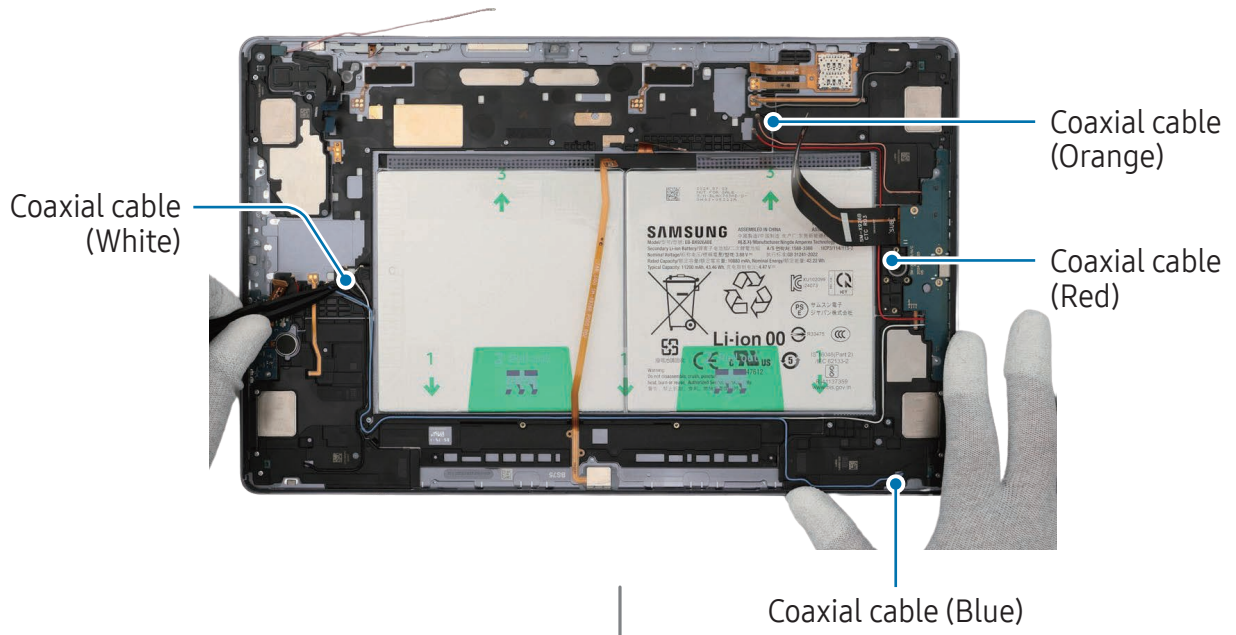

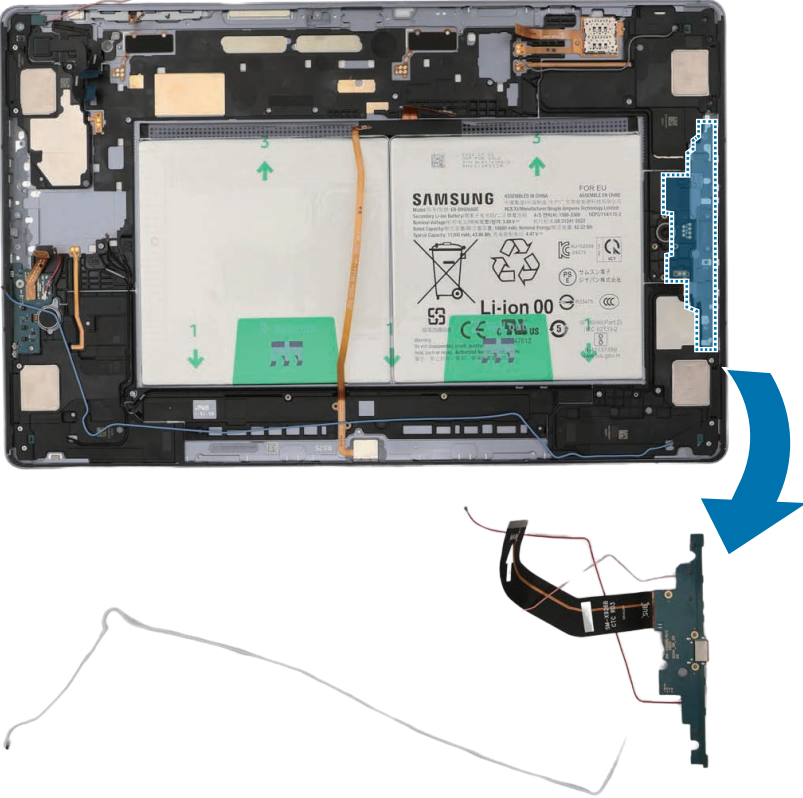
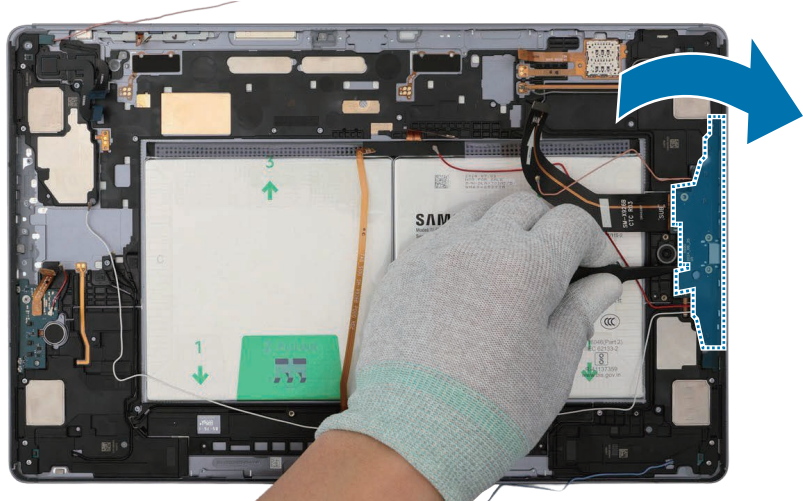

6 Heat the microwaveable heating bag and apply it to the both front and back side of the speaker module for 4 minutes.

- ⚠ • It is possible for the device or battery to be damaged by heat.
- Do not heat the device in a microwave. Doing so could cause an explosion.
- ⚠ • Follow the heating bag's instructions for heating. The recommended time for heating the bag is 50 seconds in a 1000 W microwave and 70 seconds in a 700 W microwave. (Correct temperature for use: 55-65 °C.)
- Be careful not to damage the device through excessive heat. (It is recommended to disassemble the device in an area with a temperature gauge.)
- 📄 When reheating, it should be heated no longer than 30 seconds.

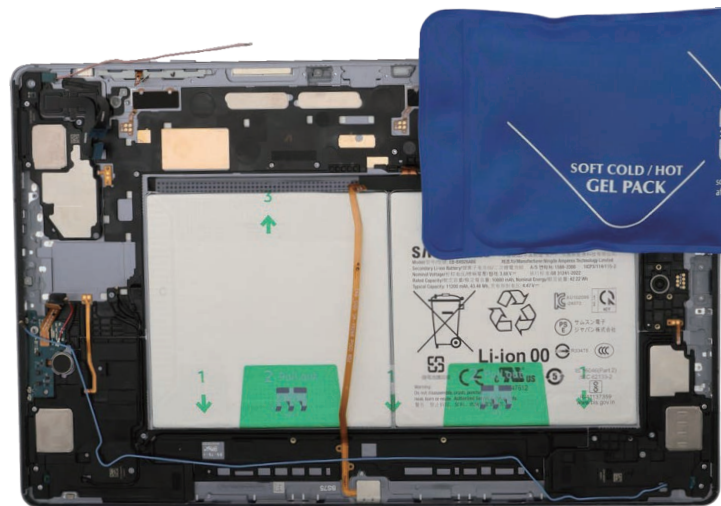

7 Using the tweezers, separate the FPCB of speaker module carefully. Insert the tweezers into the separator groove of the speaker and remove it from the back cover module.

- ⚠ • Be careful not to damage the cables and near components.

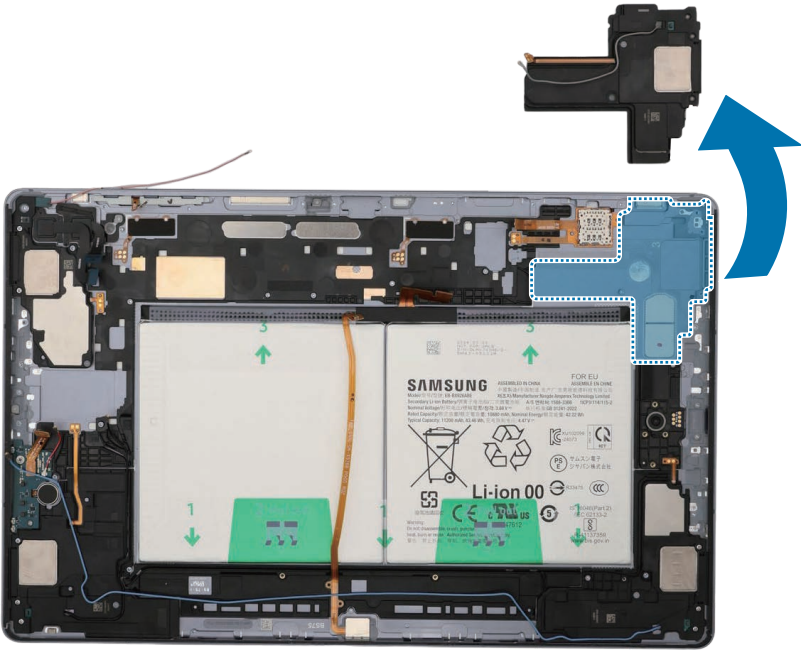
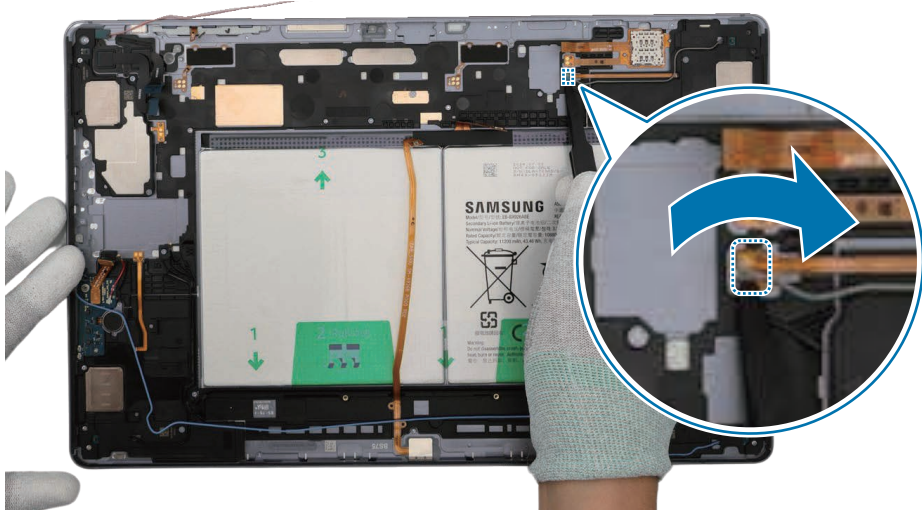

8 For the 5G or LTE devices, separate the coaxial cable connector (Grey) from the speaker module.

⚠ Be careful not to damage the cable.

- ✔ • The coaxial cable (Grey) is only available for the 5G or LTE devices.
- The cables and connectors may vary depending on the country, region, or specifications.

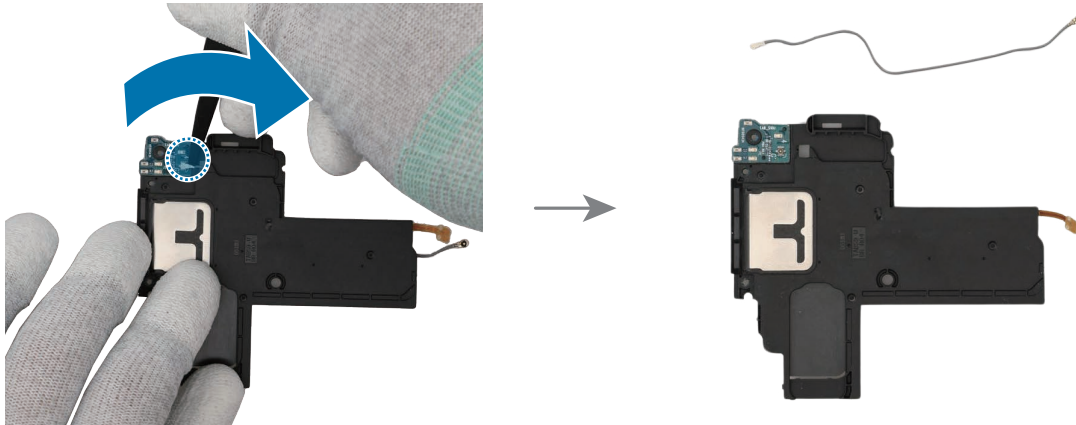

Reassembly

⚠ Leaving screws inside the device may damage internal components, such as the battery. During assembly, be extra careful not to leave any unassembled screws inside the device.

1 Using the tweezers and your fingers, remove all adhesive tapes from where the speaker was attached.

- ⚠** • Make sure to remove any residual tapes attached to the position of the separated speaker before reassembling the new speaker.
- Be careful not to damage the near components.

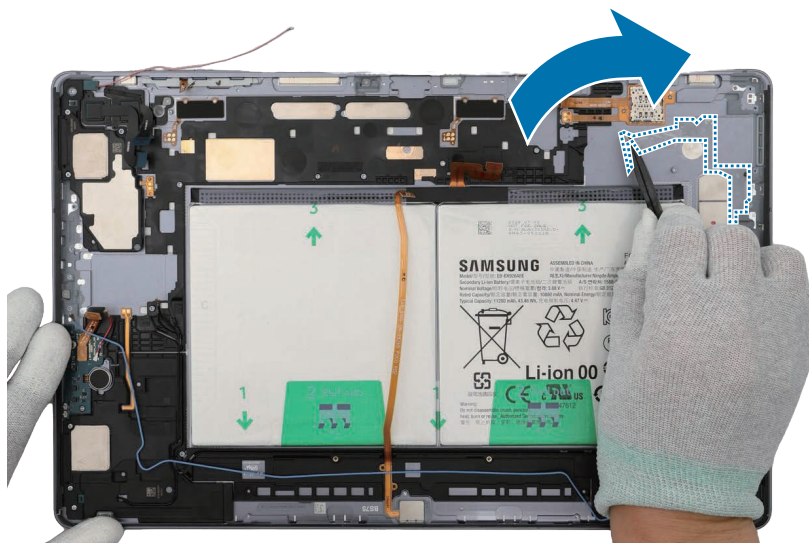

- 2 Using the tweezers, remove the release film of a new speaker 3 adhesive tape (1 ea). Align the outside shape of the tape with the speaker position and attach it accurately. Gently press down the tape with your fingers so that the tape can be attached well.

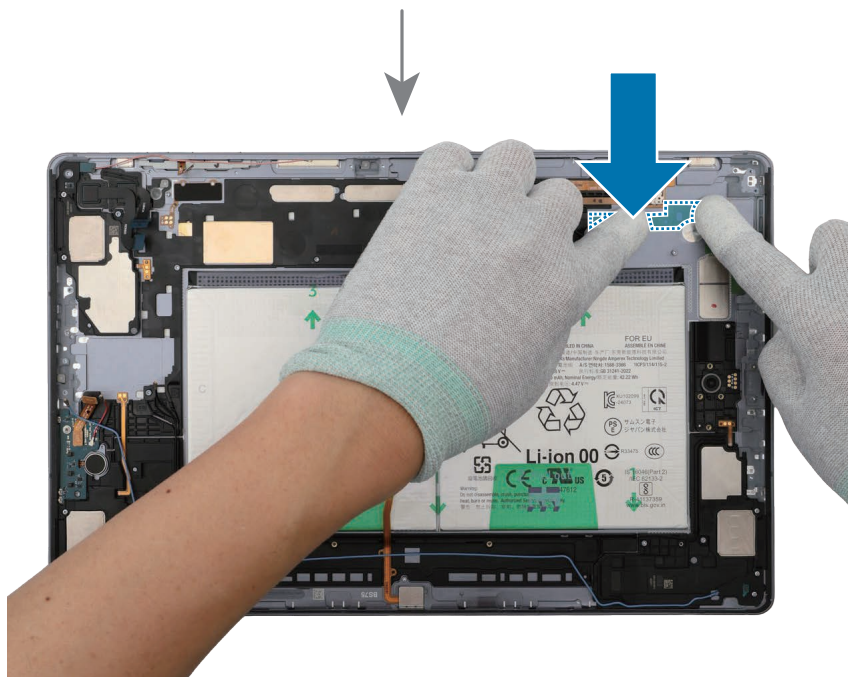
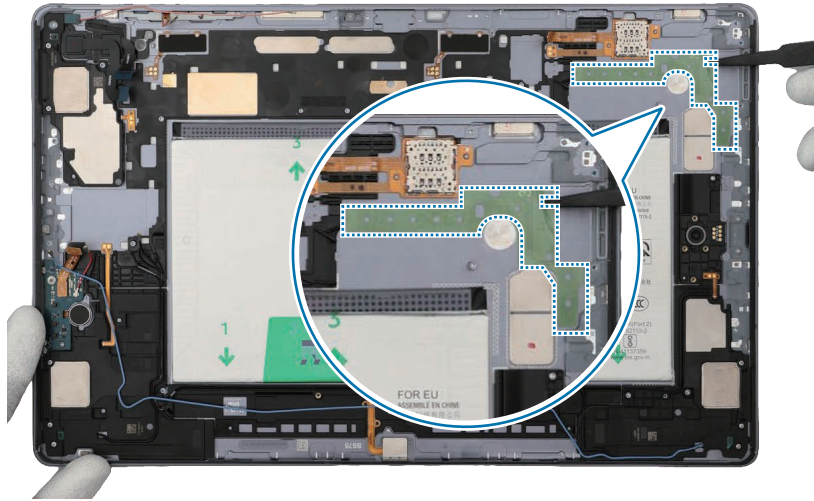

3 For the 5G or LTE devices, connect the coaxial cable connector (Grey) to the new speaker module.

⚠ Be careful not to damage the speaker and cable.

- ✔ • The coaxial cable (Grey) is only available for the 5G or LTE devices.
- The cables and connectors may vary depending on the country, region, or specifications.

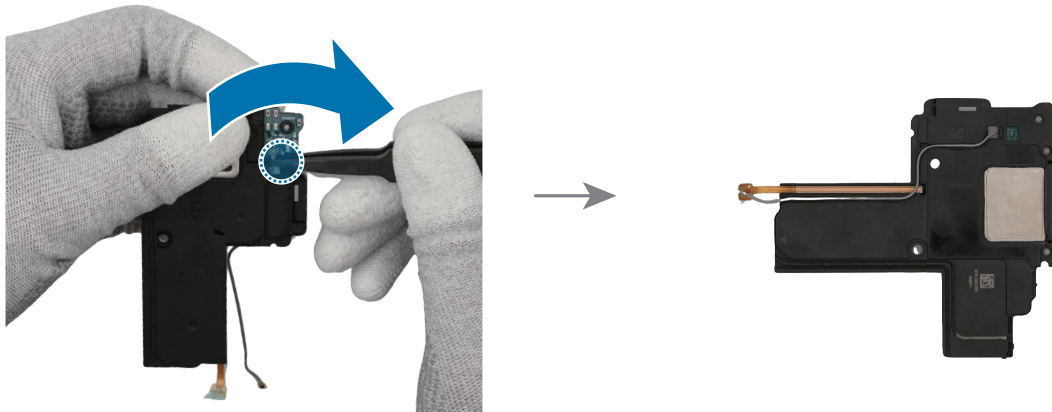

4 Using the tweezers, hold the protruding release film of the attached tape and carefully remove it.

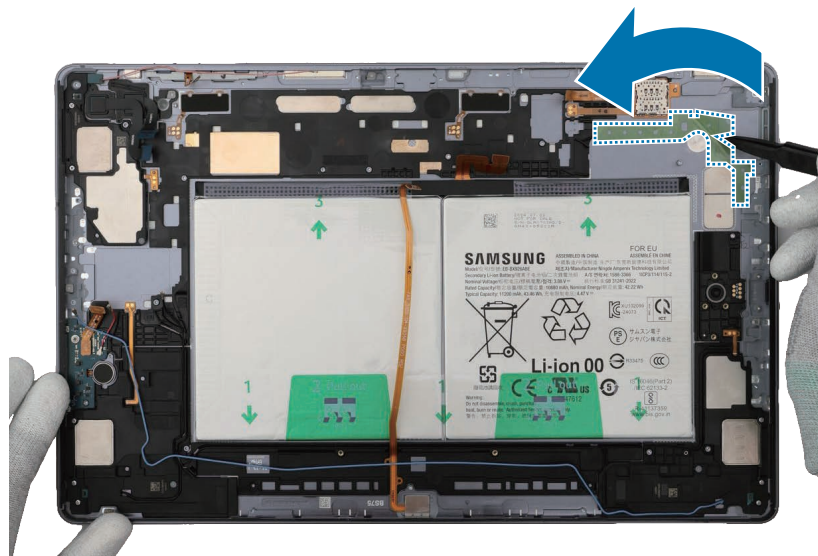

5 Using the tweezers or your fingers, remove the release film of the new speaker. Place the speaker module to the exact position, and assemble it to the back cover module.

 Be careful not to damage the battery.

 • The cables have to be positioned outside so as not to interfere when assembling the speaker.

• Be careful not to damage the speaker and cable.

• Be careful not to damage the near components.

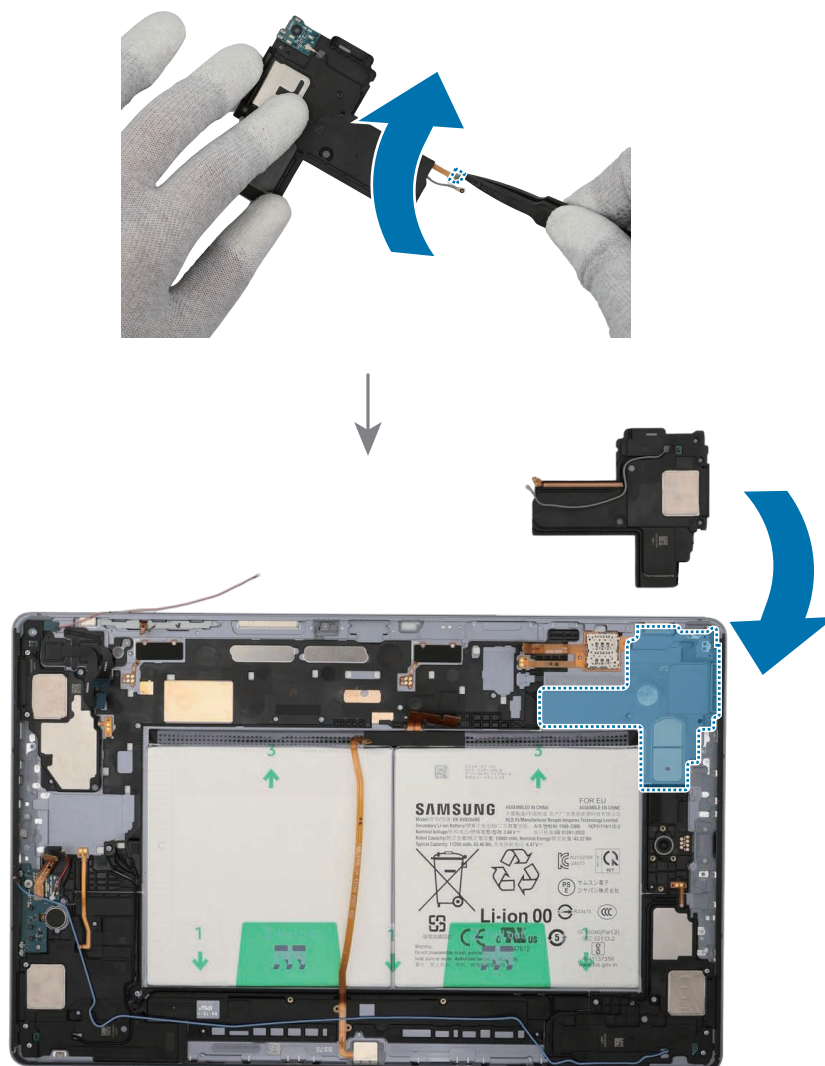

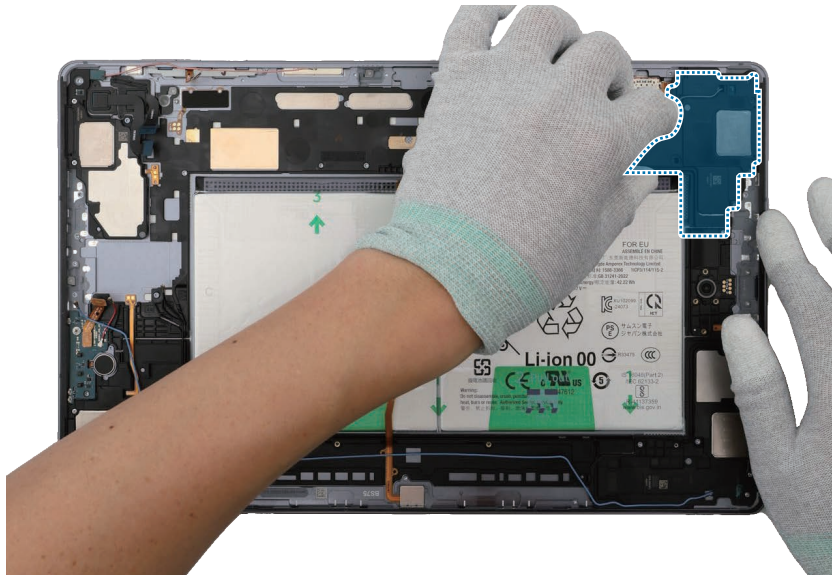

6 Using your fingers, press down softly and evenly on the speaker module and the FPCB so that the speaker module can be completely attached.

⚠ Be careful not to damage the speaker and FPCB.

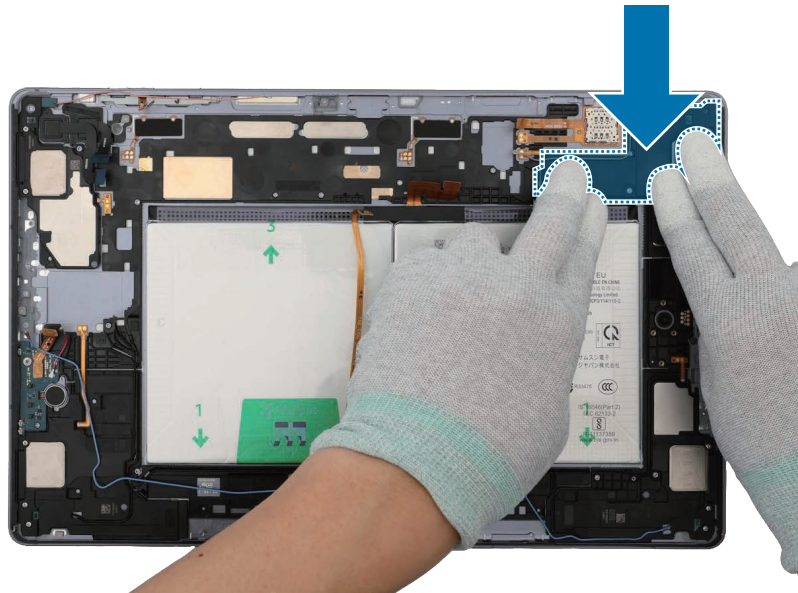
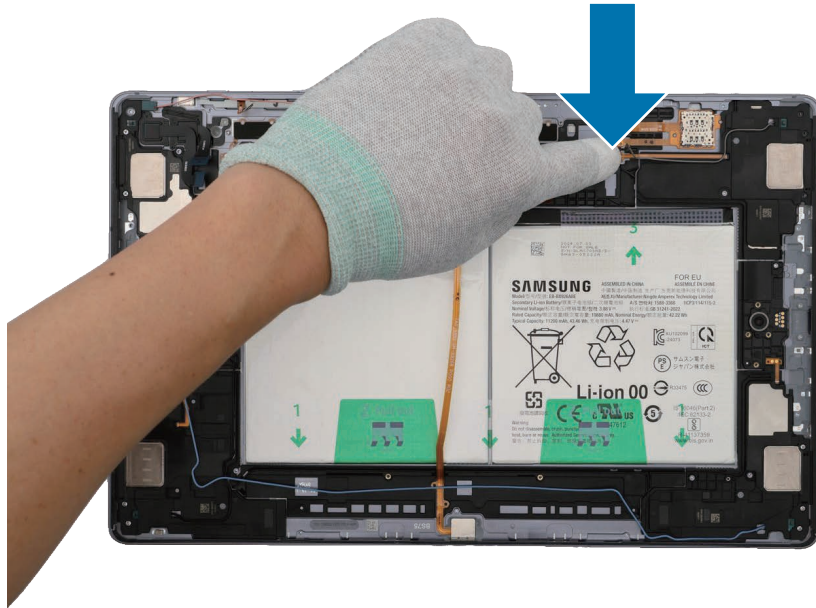

7 Using the tweezers or your fingers, assemble the charging port to the back cover module and press down softly and evenly on it so that the charging port can be completely attached.

- ❗ • Be careful not to damage the charging port module side contact.
- Be careful not to damage the near components.

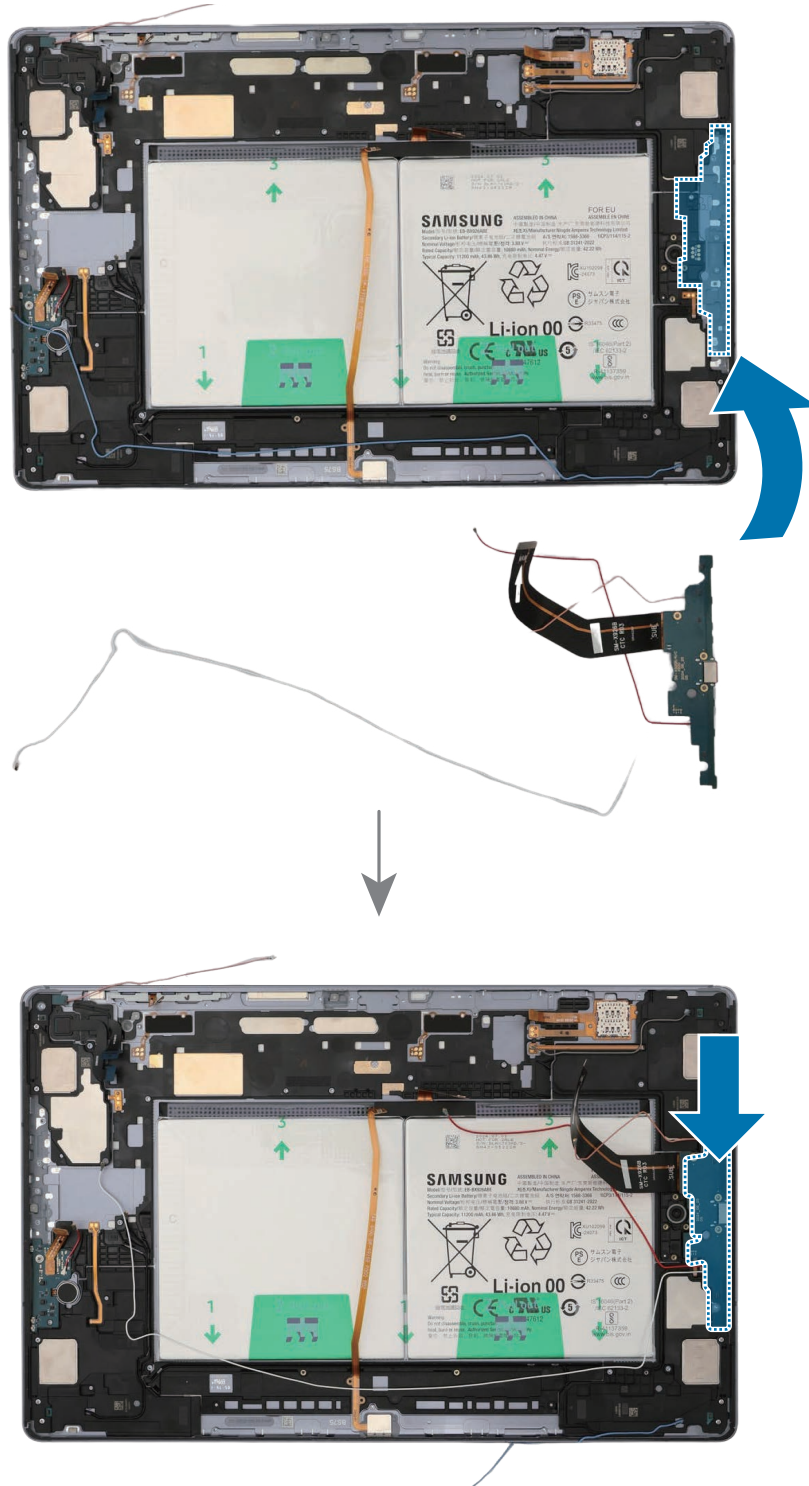

8 For the 5G or LTE devices, connect the 4 coaxial cables (Orange/Red/White/Blue) to the speaker modules.

- ⚠ • Be careful not to damage the charging port and near components.
- Be careful not to damage the cables.
- ✍ • The 4 coaxial cables (Orange/Red/White/Blue) are only available for the 5G or LTE devices.
- The cables and connectors may vary depending on the country, region, or specifications.

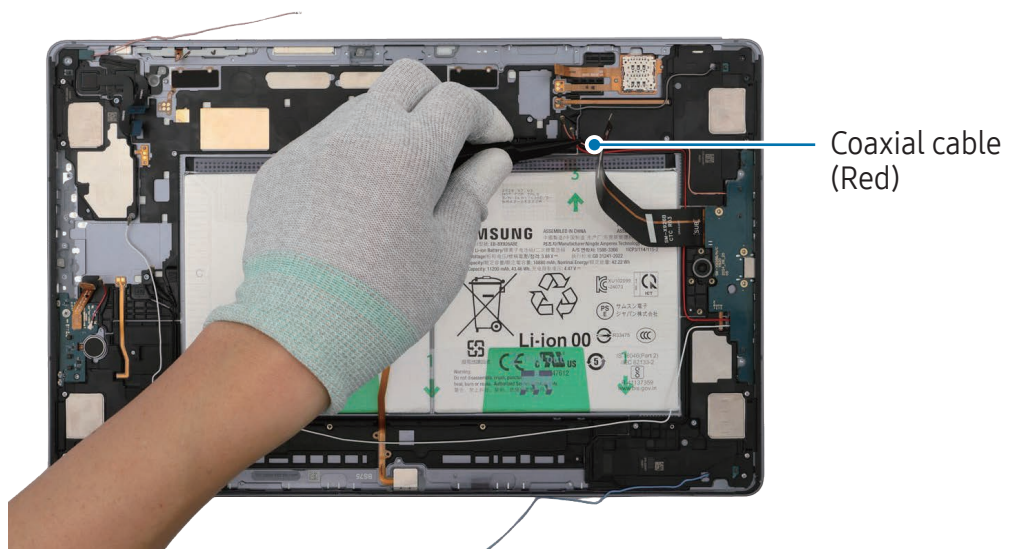

Coaxial cable
(White)

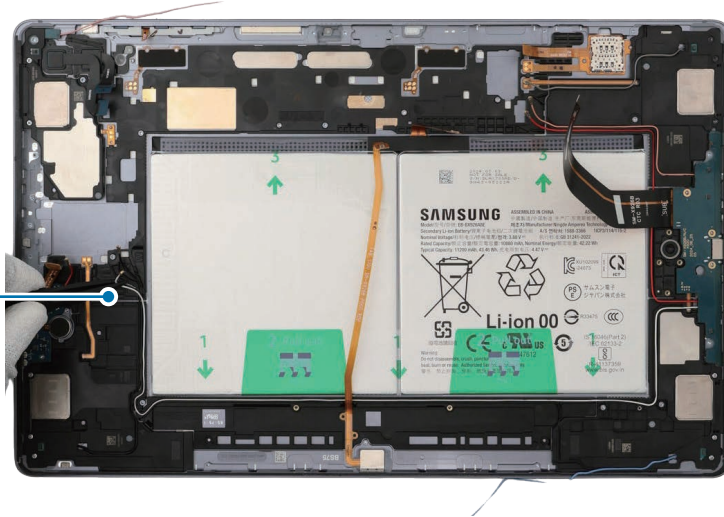

Coaxial cable
(Blue)

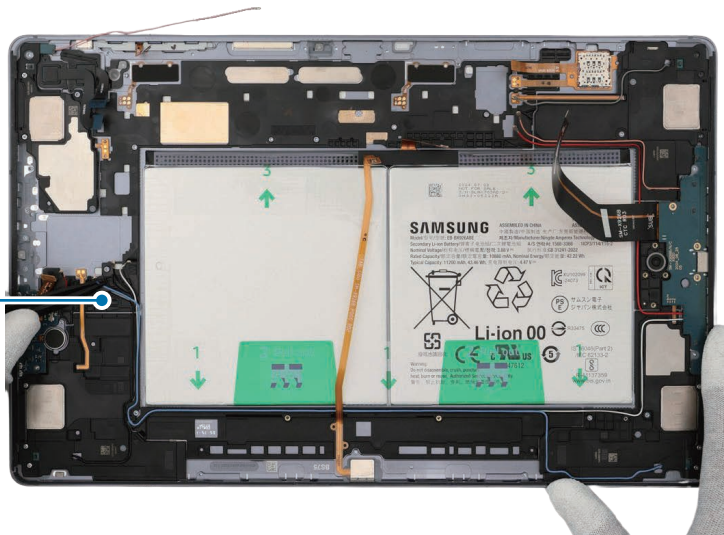

9 Check the screw 3443 (3 ea) and fasten them on the charging port using a cross-head screwdriver.

⚠ Be careful not to damage the charging port and near components.

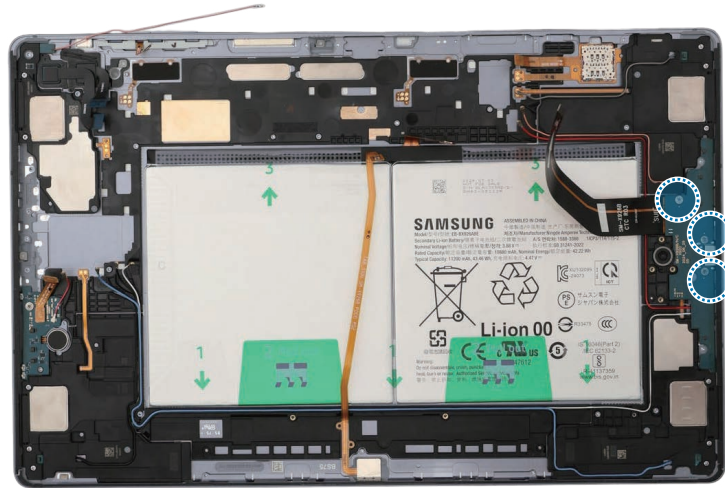

10 Check the screw 3405 (3 ea) and fasten them on the speaker using a cross-head screwdriver.

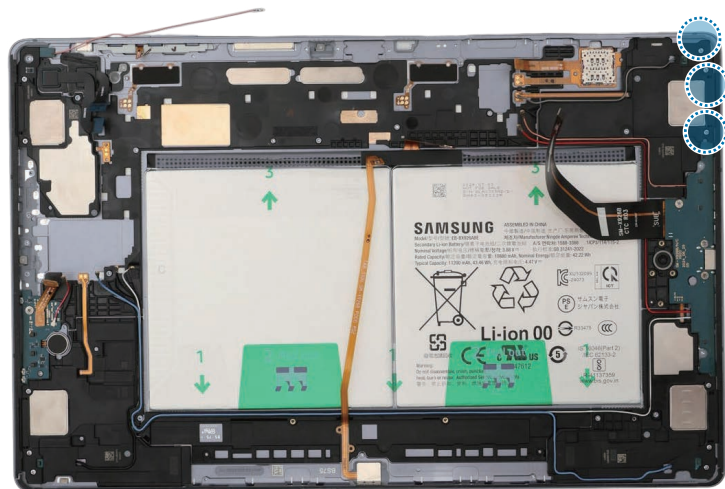

11 Place the main board to the exact position, and assemble it to the back cover module.

- ❗ • The cables have to be positioned outside so as not to interfere when assembling the main board.
- Be careful not to damage the main board and near components.

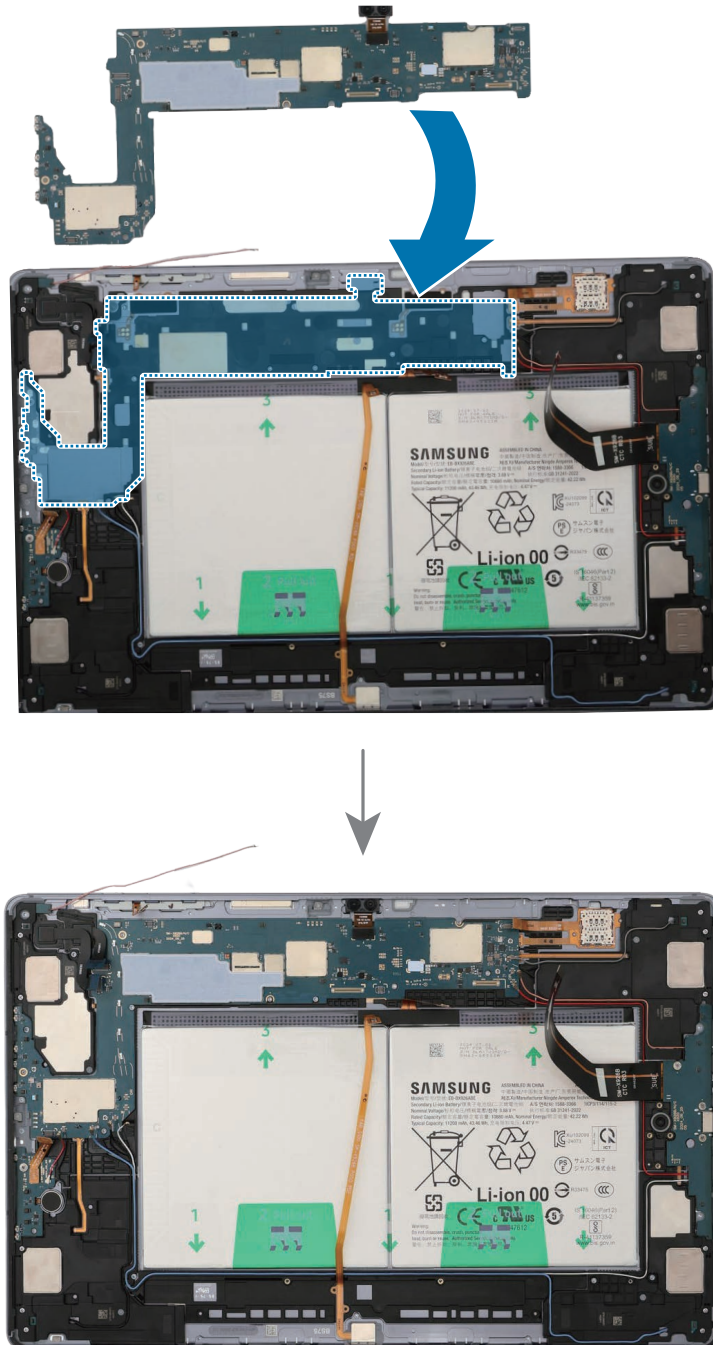

12 Using the tweezers, connect the coaxial cable (Orange) to the main board.

⚠ Be careful not to damage the cables and near components.

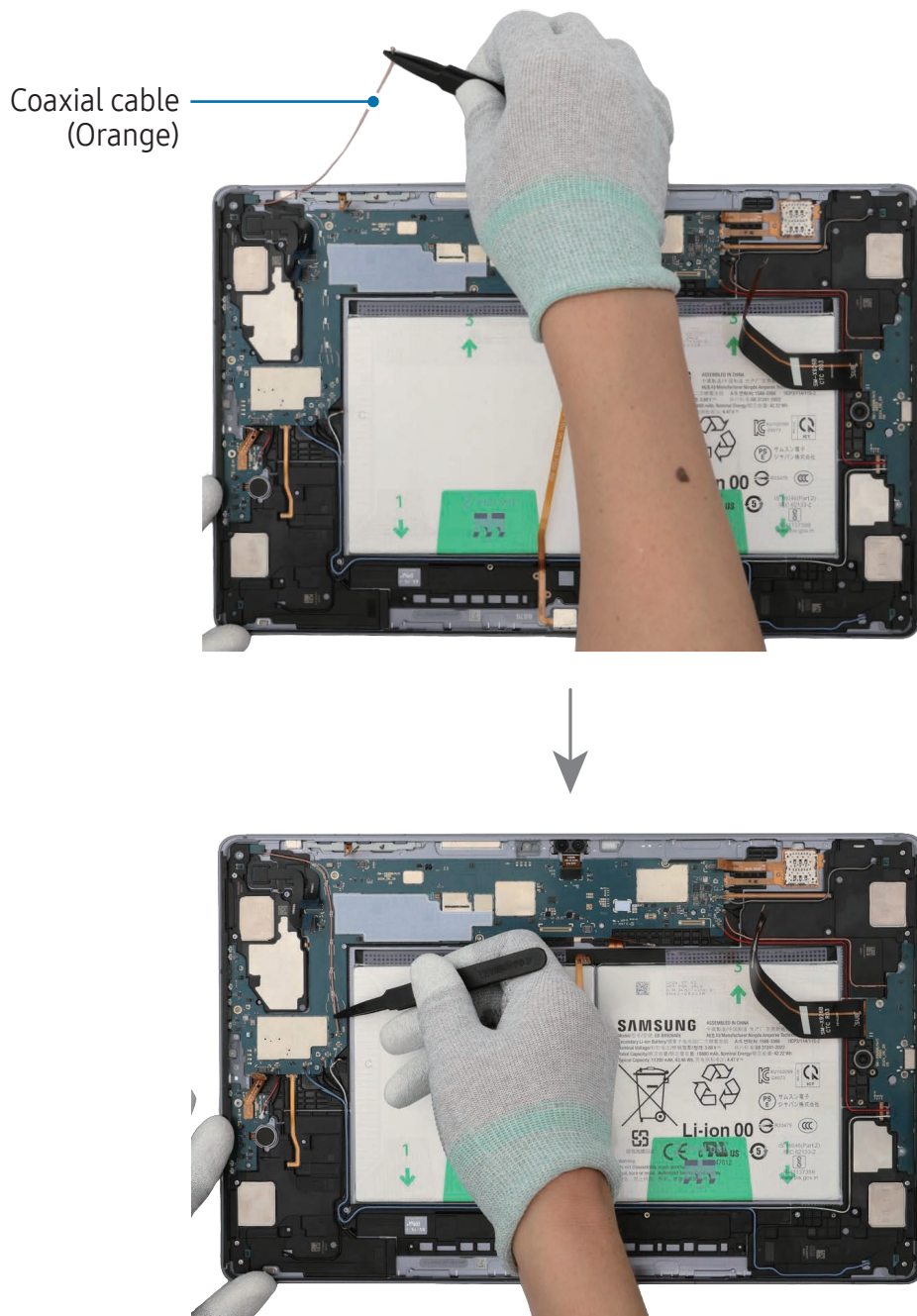

13 Check the screw 3463 (4 ea) and fasten them on the main board using a cross-head screwdriver.

⚠ Be careful not to damage the main board and near components.

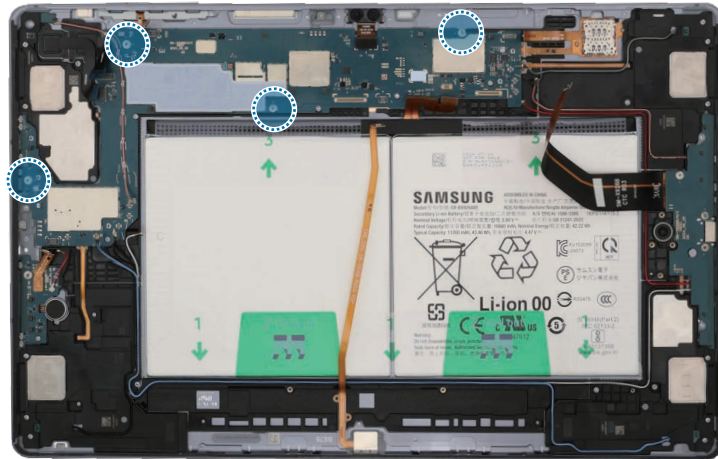

14 Using the tweezers, connect the 8 connectors and the 3 coaxial cable connectors (Orange/Red/Black) to the main board. For the 5G or LTE devices, connect the additional 5 coaxial cable connectors (Blue/White/Grey/Orange/Red).

⚠

- Be careful not to damage the cable while connecting the connector.
- Be careful not to damage the near components.



- The 5 coaxial cables (Blue/White/Grey/Orange/Red) are only available for the 5G or LTE devices.
- The cables and connectors may vary depending on the country, region, or specifications.

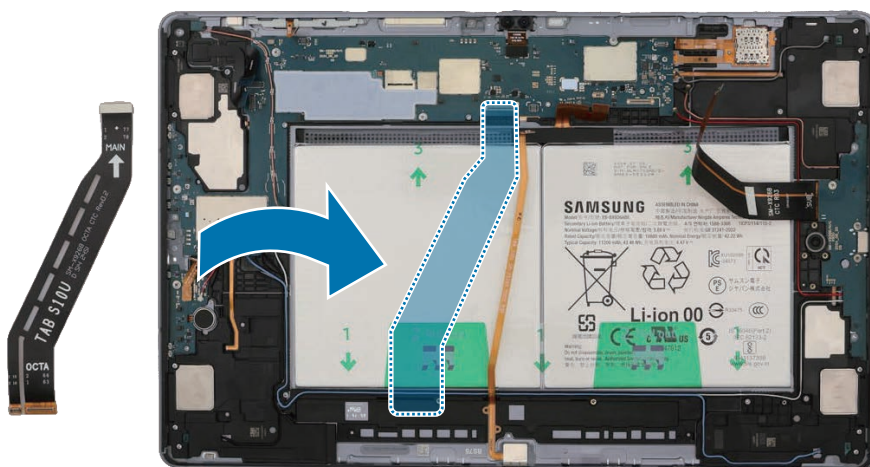

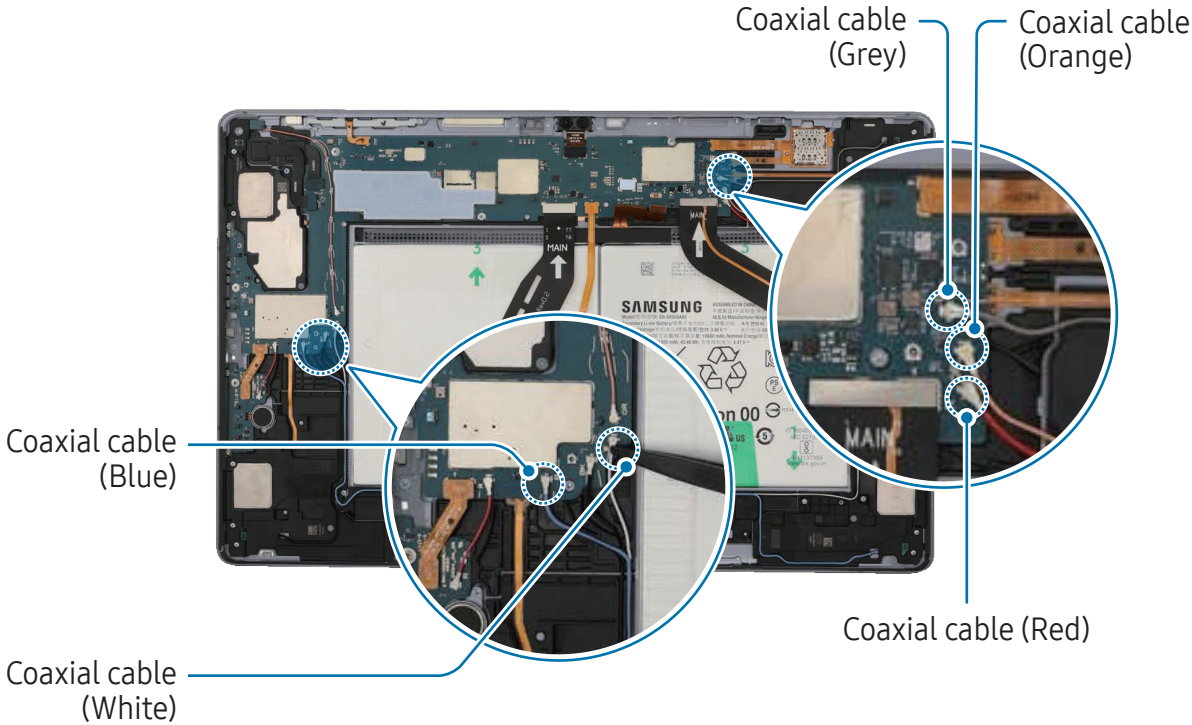
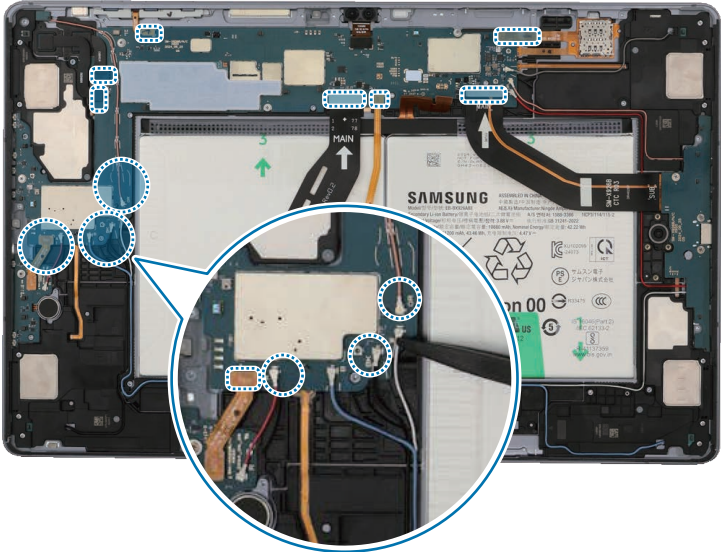

15 Connect the battery connector to the main board.

⚠ Be careful not to damage the battery.

⚠ Be careful not to damage the battery connector and near components.

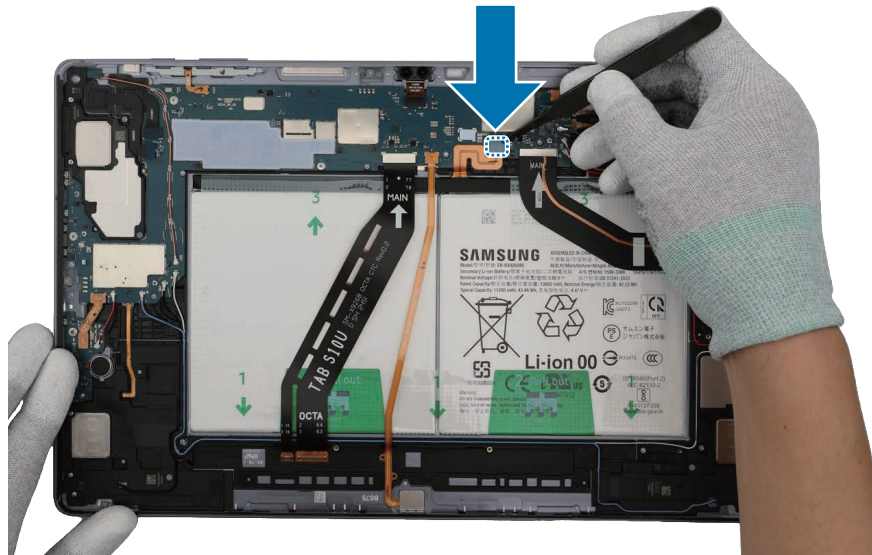

👉 Reassemble the **Bracket** and **Screen** to complete assembly.

Speaker 4

Disassembly

 Remove the [Screen](#) and [Bracket](#) first before you begin.

1 Using the tweezers, disconnect the battery connector from the main board first. Separate the 3 connectors and the coaxial cable connector (Black) from the main board. For the 5G or LTE devices, separate the additional 4 coaxial cable connectors (Blue/White/Orange/Red).

 • Make sure to first disconnect the battery connector for your own safety.
• Be careful not to damage the battery.

 • Be careful not to damage the cable while removing the connector.
• Be careful not to damage the near components.

 • The 4 coaxial cables (Blue/White/Orange/Red) are only available for the 5G or LTE devices.
• The cables and connectors may vary depending on the country, region, or specifications.

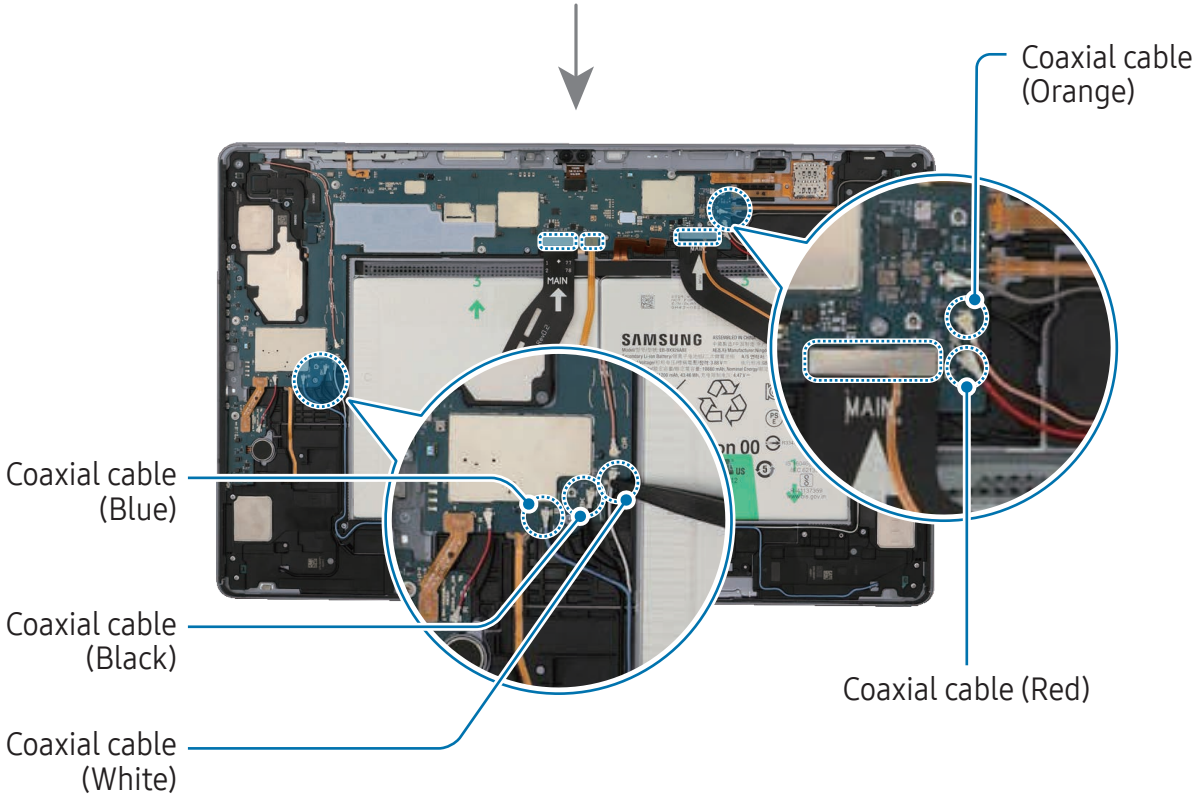
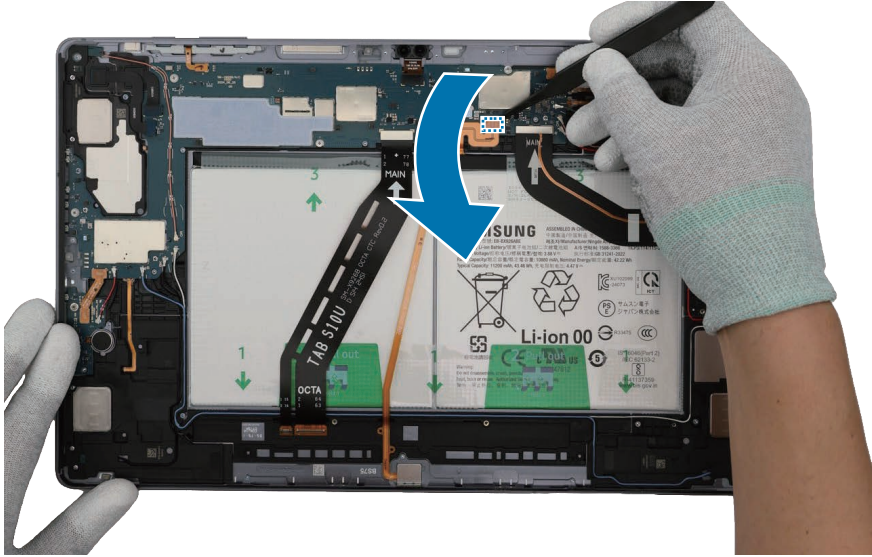

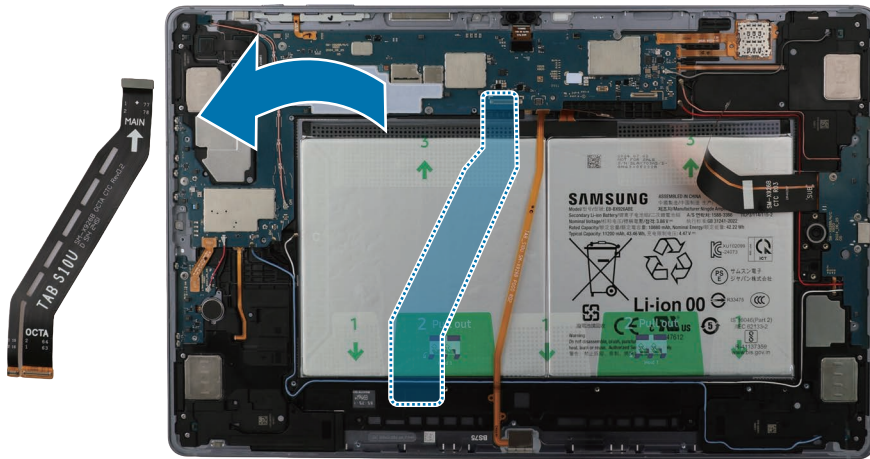

2 Check the 3 screws on the speaker and the 3 screws on the charging port. Remove all 6 screws using a cross-head screwdriver.



Be careful not to damage the charging port and near components.



Check the number of screws that have been removed, and store them carefully to make sure that no unassembled screws are left inside the device during assembly.

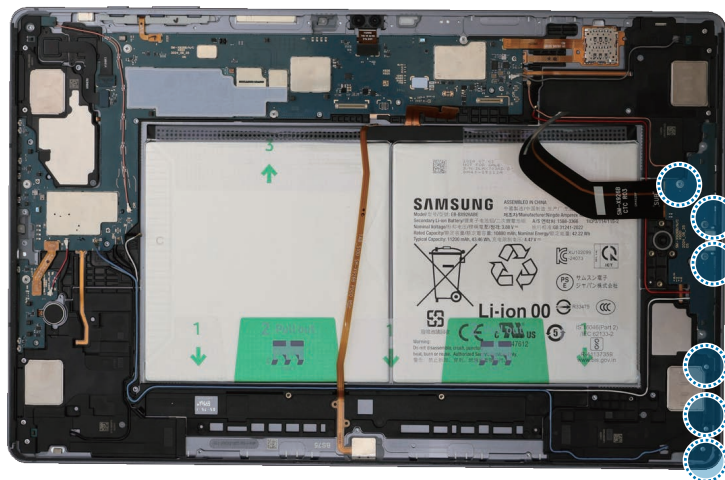

3 For the 5G or LTE devices, disconnect the 4 coaxial cables (Blue/White/Orange/Red) in the speaker modules with the tweezers. Using the tweezers, lift up on the separator groove of the charging port module, and remove it carefully.

- ⚠ • Check the position of the overlapping cables and disconnect them in order from the top.
- Be careful not to damage the cables and near components.
- ✍ • The 4 coaxial cables (Blue/White/Orange/Red) are only available for the 5G or LTE devices.
- The cables and connectors may vary depending on the country, region, or specifications.

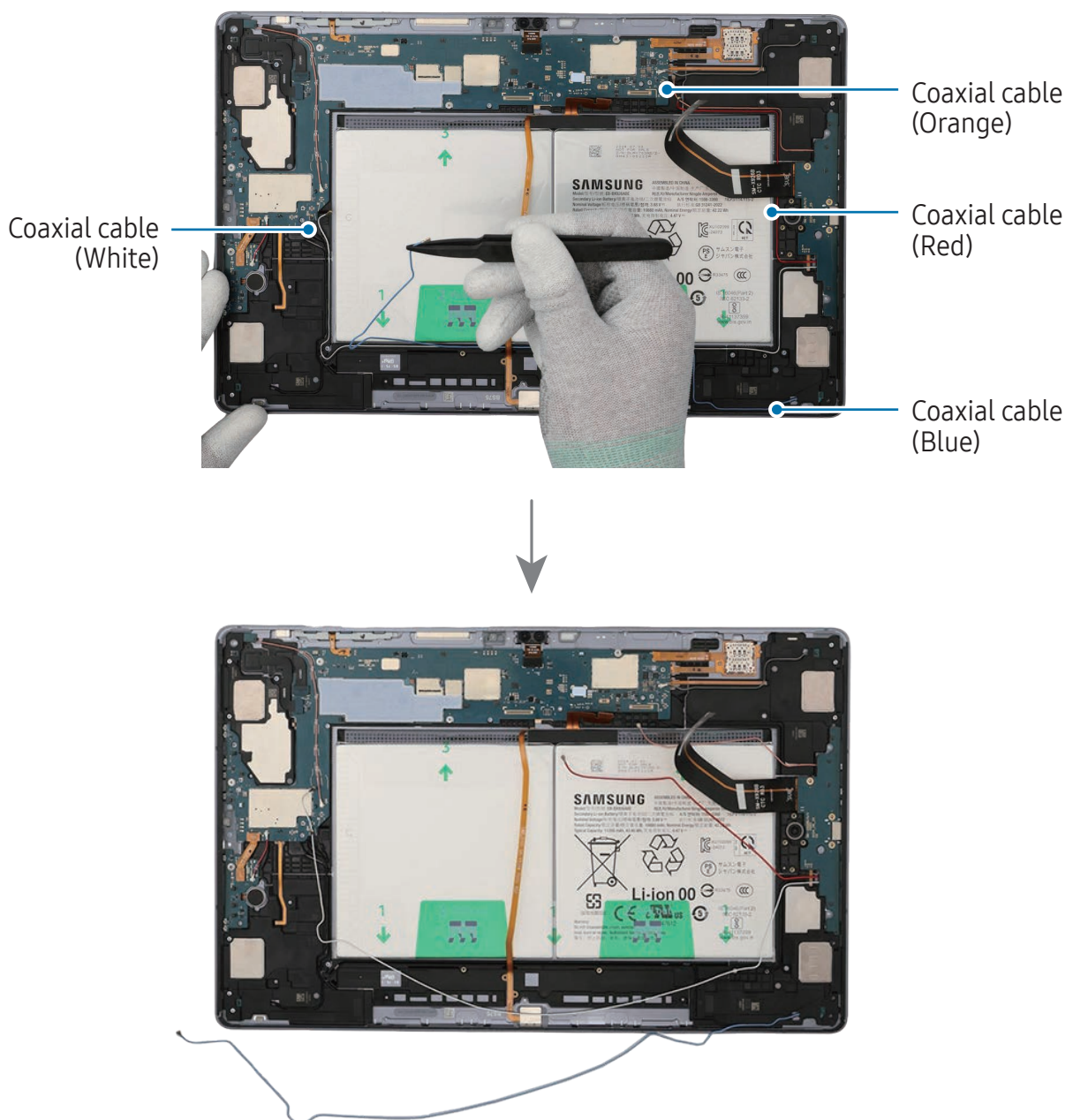

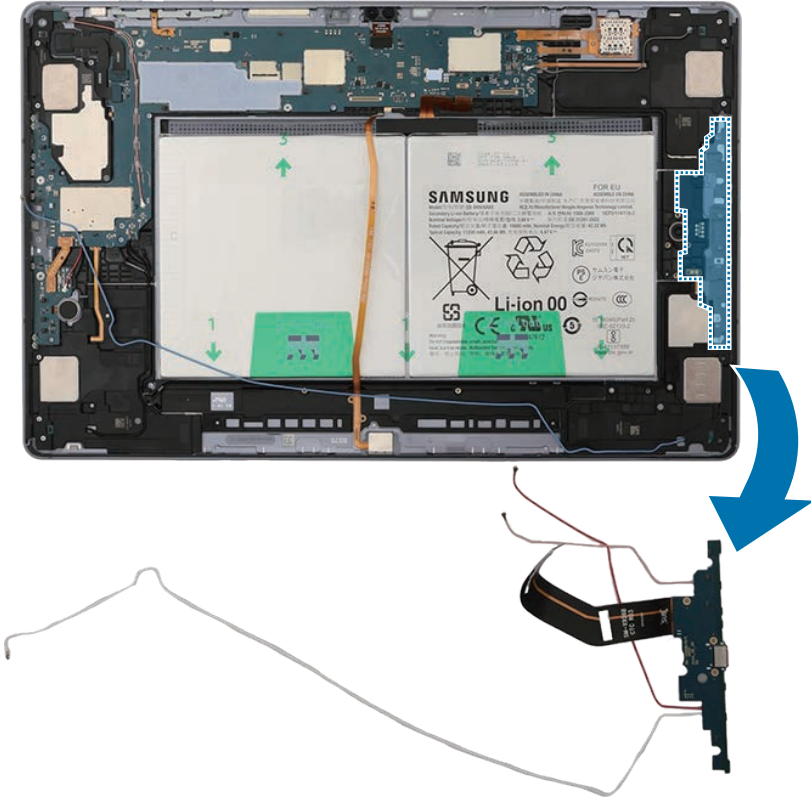

4 Heat the microwaveable heating bag and apply it to the both front and back side of the speaker module for 4 minutes.

- ⚠ • It is possible for the device or battery to be damaged by heat.
- Do not heat the device in a microwave. Doing so could cause an explosion.
- ⚠ • Follow the heating bag's instructions for heating. The recommended time for heating the bag is 50 seconds in a 1000 W microwave and 70 seconds in a 700 W microwave. (Correct temperature for use: 55-65 °C.)
- Be careful not to damage the device through excessive heat. (It is recommended to disassemble the device in an area with a temperature gauge.)
- 📄 • When reheating, it should be heated no longer than 30 seconds.

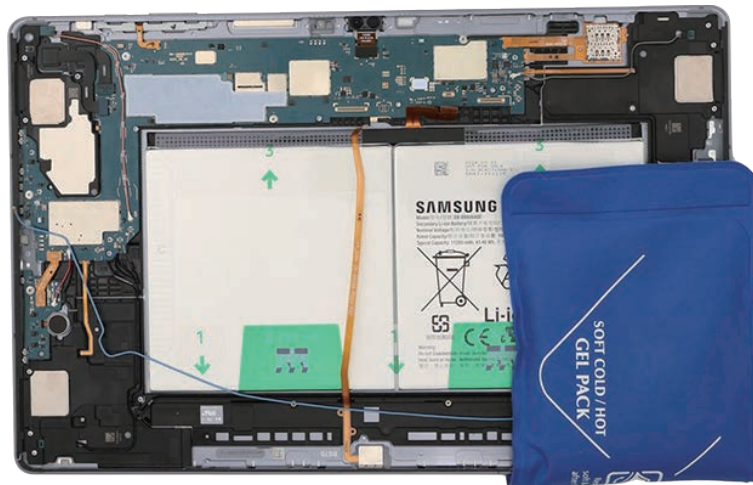

5 Using the tweezers, separate the FPCB of the speaker module carefully. Insert the tweezers into the separator groove of the speaker and remove it from the back cover module.

⚠ Be careful not to damage the cables and near components.

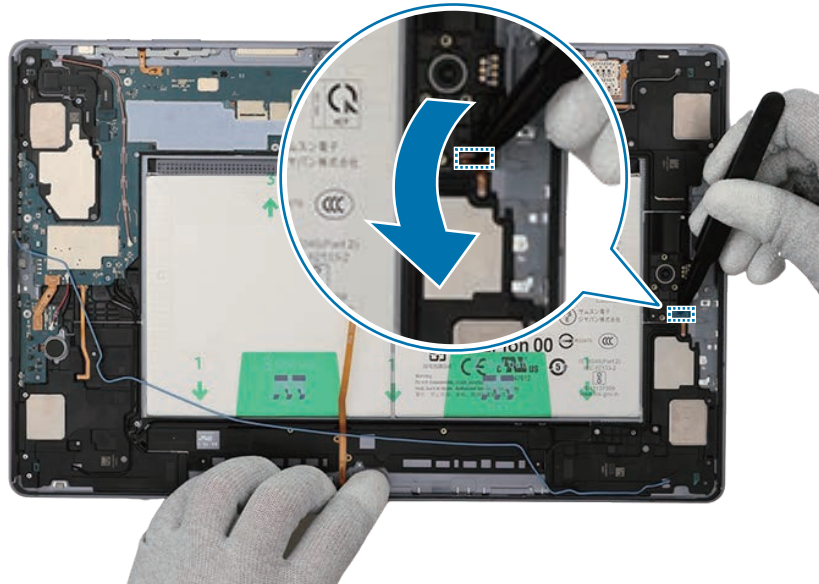

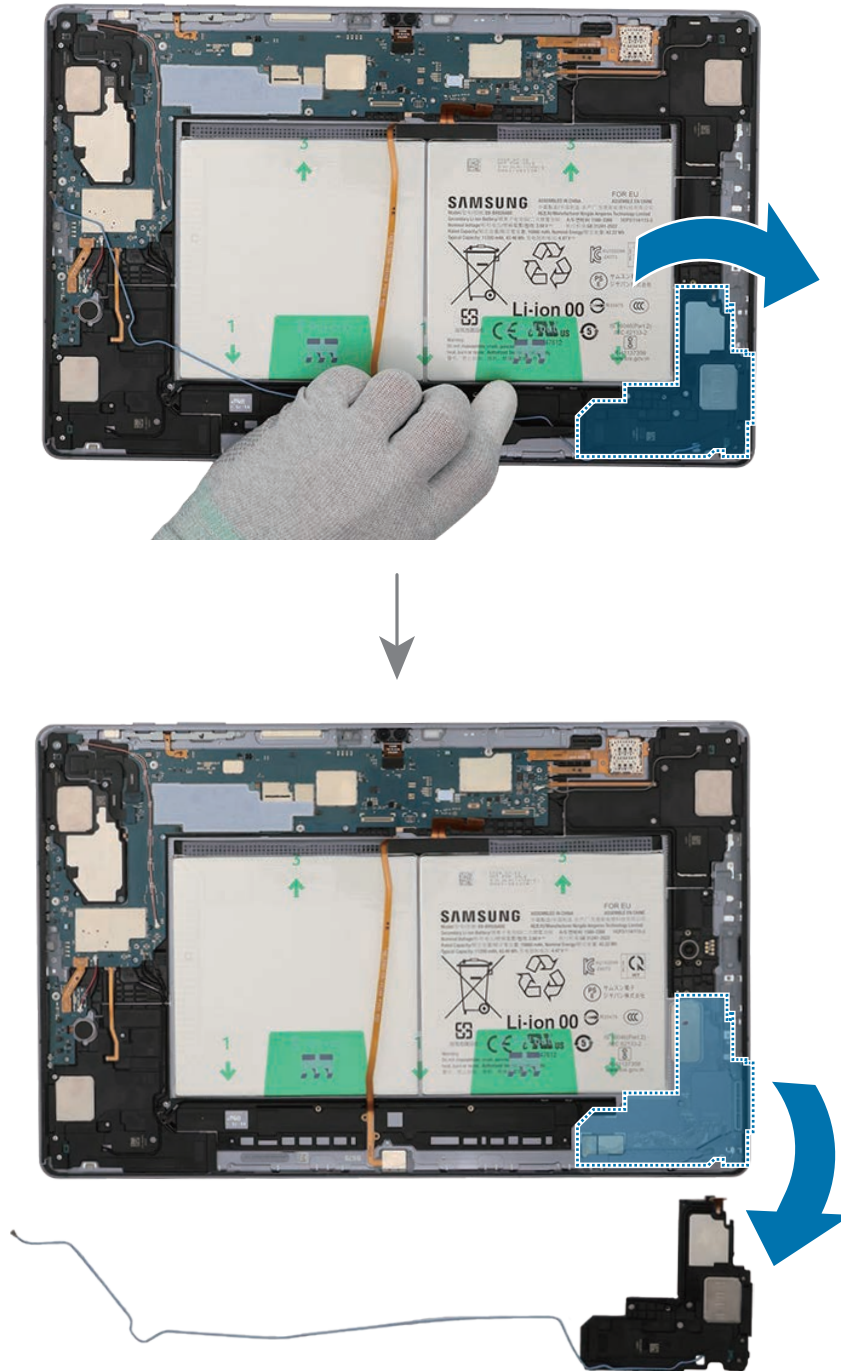



6 For the 5G or LTE devices, separate the coaxial cable connector (Blue) from the speaker module.

⚠ Be careful not to damage the cable.

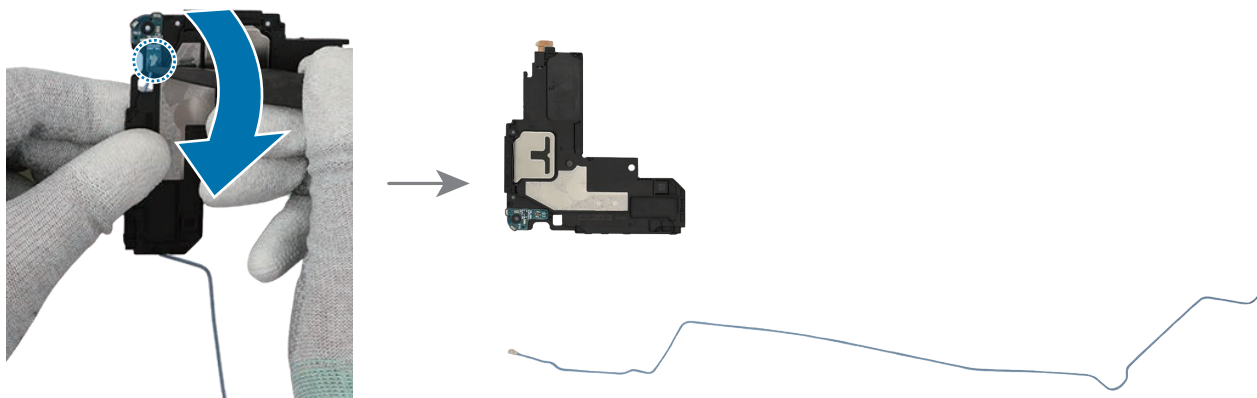
- ✔ • The coaxial cable (Blue) is only available for the 5G or LTE devices.
- The cables and connectors may vary depending on the country, region, or specifications.



Reassembly

 Leaving screws inside the device may damage internal components, such as the battery. During assembly, be extra careful not to leave any unassembled screws inside the device.

1 Using the tweezers and your fingers, remove all adhesive tapes from where the speaker was attached.

-  • Make sure to remove any residual tapes attached to the position of the separated speaker before reassembling the new speaker.
- Be careful not to damage the near components.

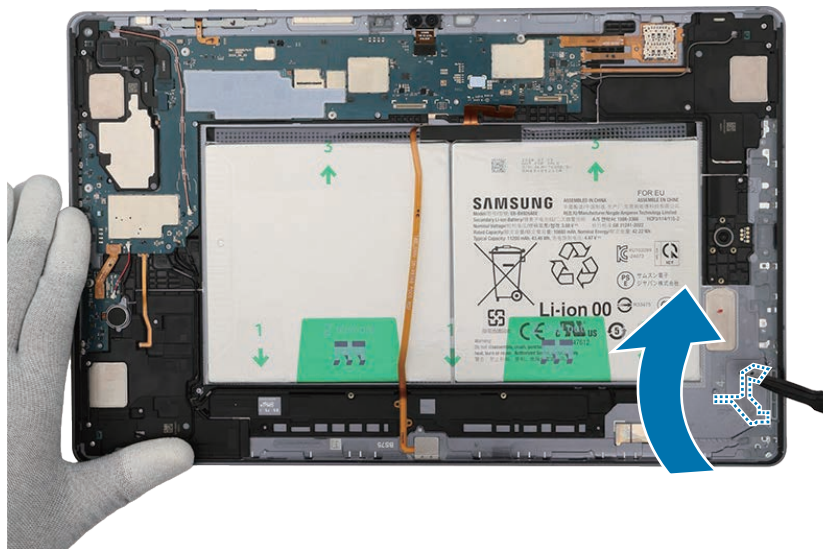

- 2 Using the tweezers, remove the release film of a new speaker 4 adhesive tape (1 ea). Align the outside shape of the tape with the speaker position and attach it accurately. Gently press down the tape with your fingers so that the tape can be attached well.

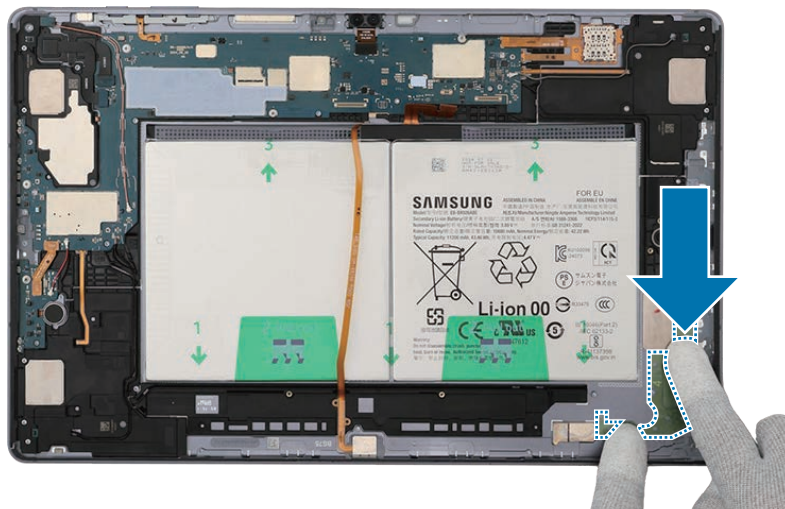
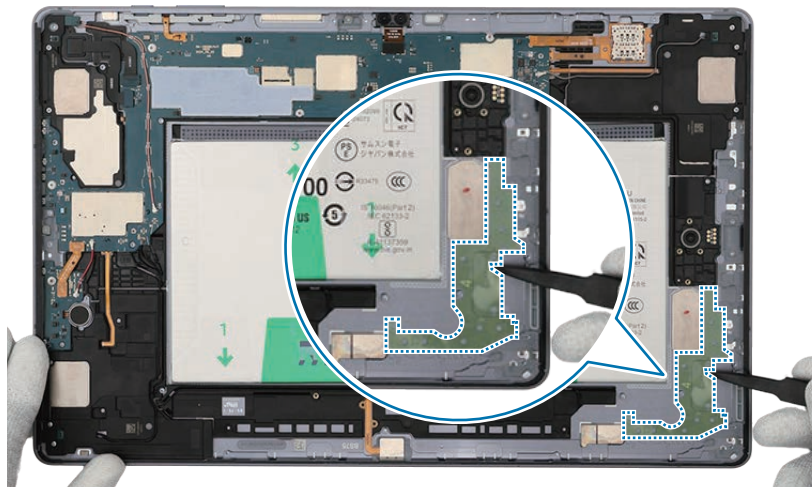

3 For the 5G or LTE devices, connect the coaxial cable connector (Blue) to the new speaker module.

⚠ Be careful not to damage the speaker and cable.

- 📌 • The coaxial cable (Blue) is only available for the 5G or LTE devices.
- The cables and connectors may vary depending on the country, region, or specifications.

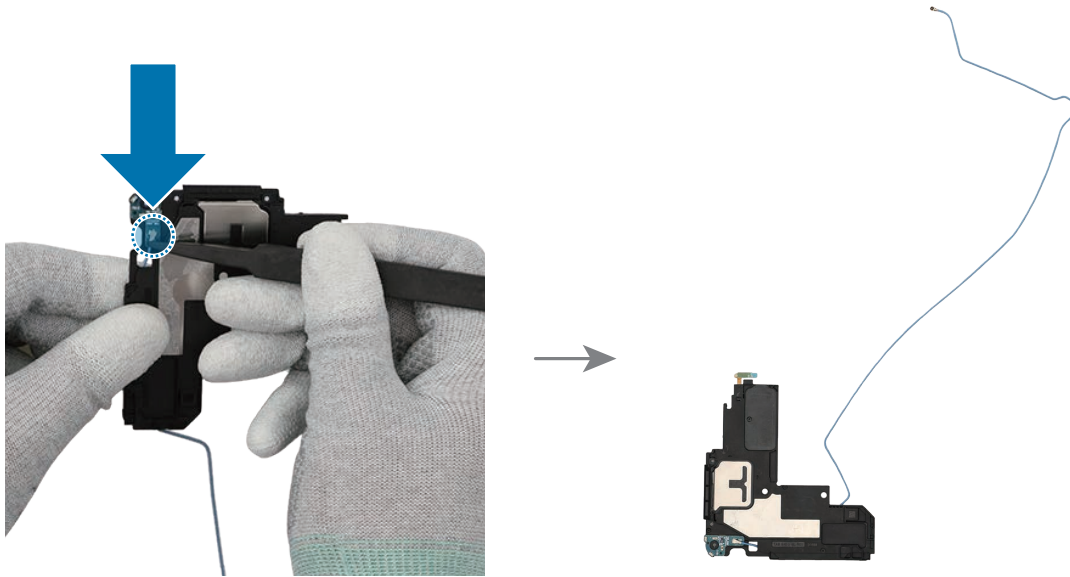

4 Using the tweezers, hold the protruding release film of the attached tape and carefully remove it.

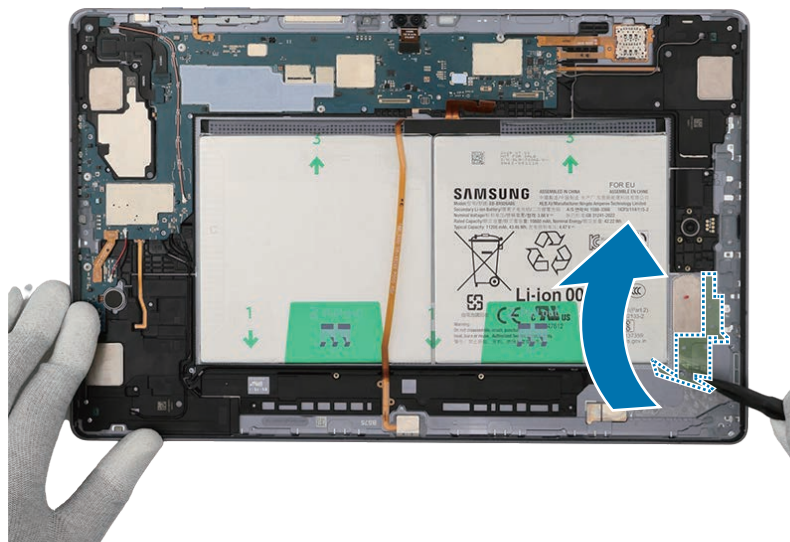

5 Using the tweezers or your fingers, remove the release film of the new speaker. Place the speaker module to the exact position, and assemble it to the back cover module.

 Be careful not to damage the battery.

-  • The cables have to be positioned outside so as not to interfere when assembling the speaker.
- Be careful not to damage the speaker and cable.
- Be careful not to damage the near components.

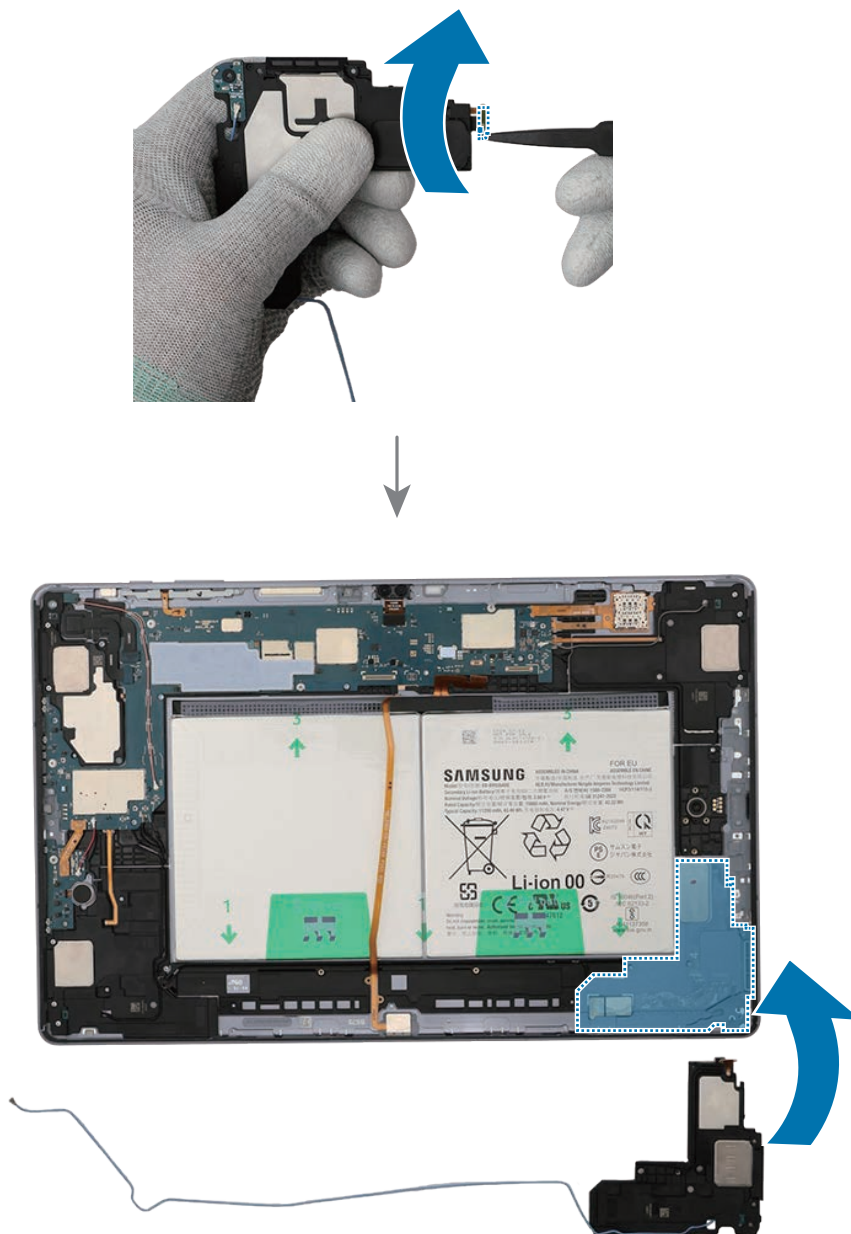

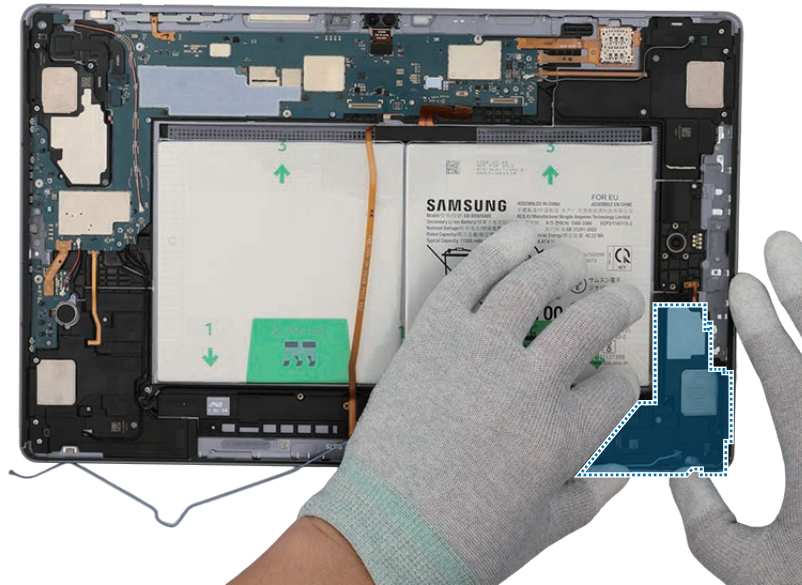

6 Using your fingers, press down softly and evenly on the speaker module and the FPCB so that the speaker module can be completely attached.

⚠ Be careful not to damage the speaker and FPCB.

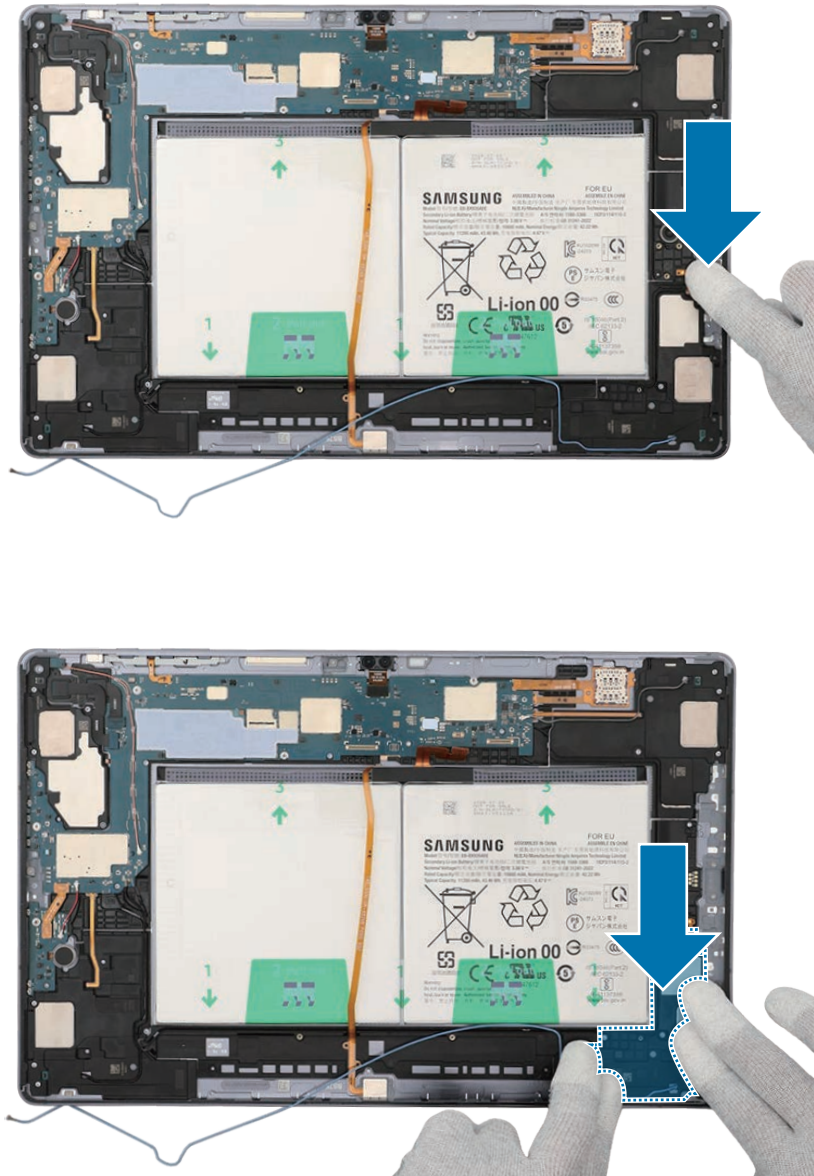

7 Using the tweezers or your fingers, assemble the charging port to the back cover module and press down softly and evenly on it so that the charging port can be completely attached.

- ⚠ • Be careful not to damage the charging port module side contact.
- Be careful not to damage the near components.

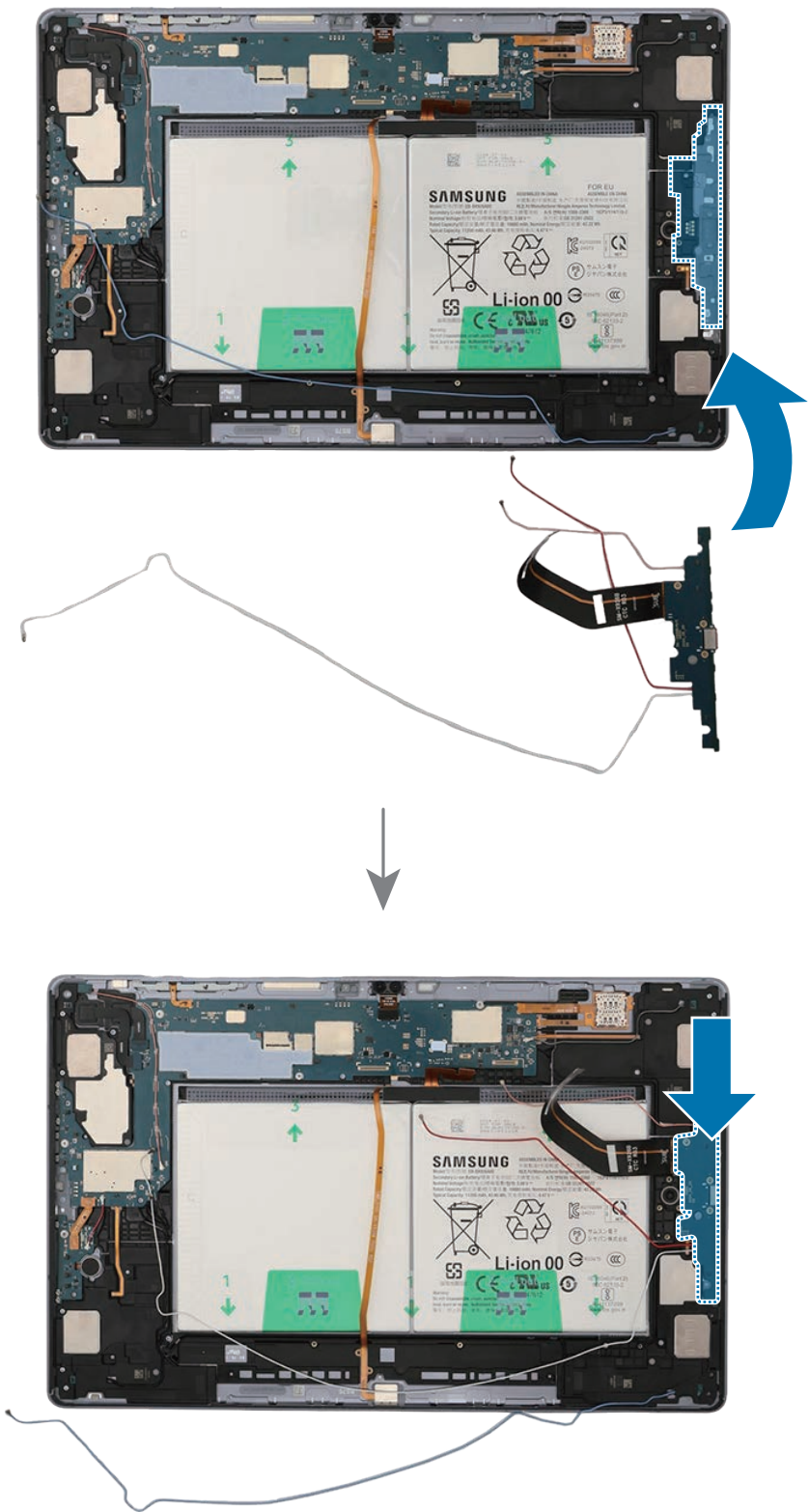

8 For the 5G or LTE devices, connect the 4 coaxial cables (Orange/Red/White/Blue) to the speaker modules.

- ⚠ • Be careful not to damage the charging port and near components.
- Be careful not to damage the cables.
- 📌 • The 4 coaxial cables (Orange/Red/White/Blue) are only available for the 5G or LTE devices.
- The cables and connectors may vary depending on the country, region, or specifications.

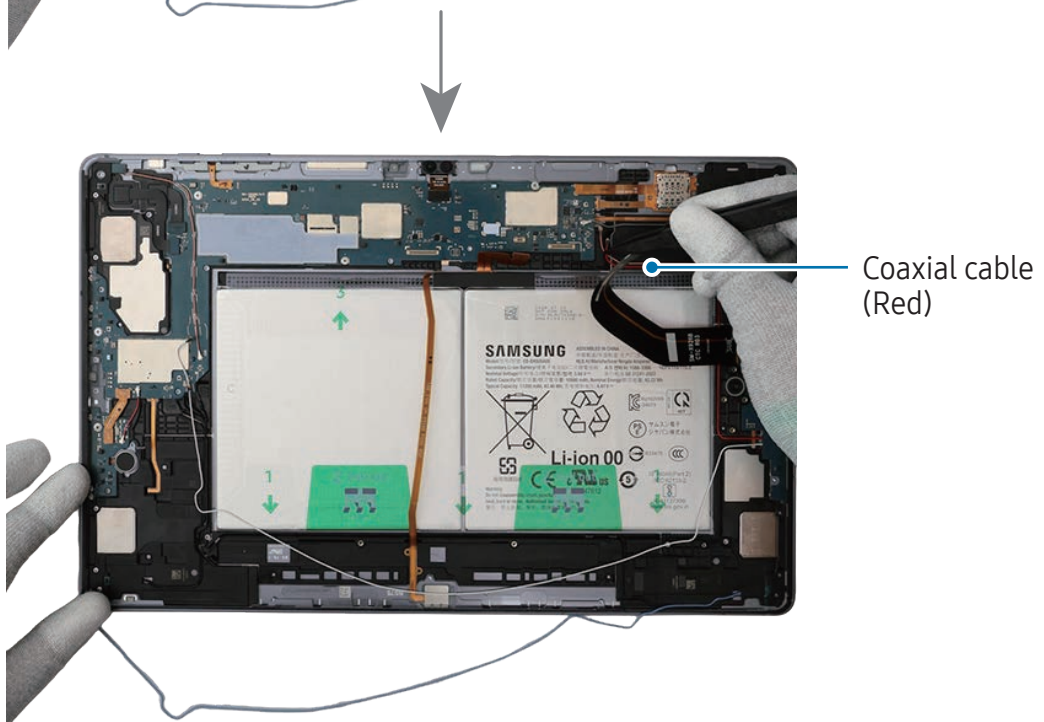
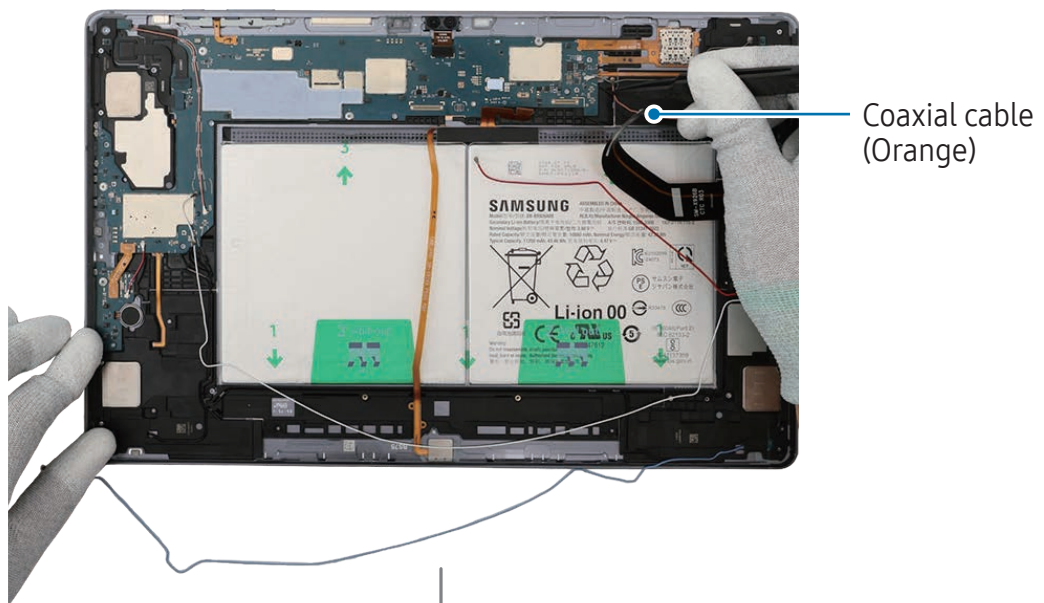

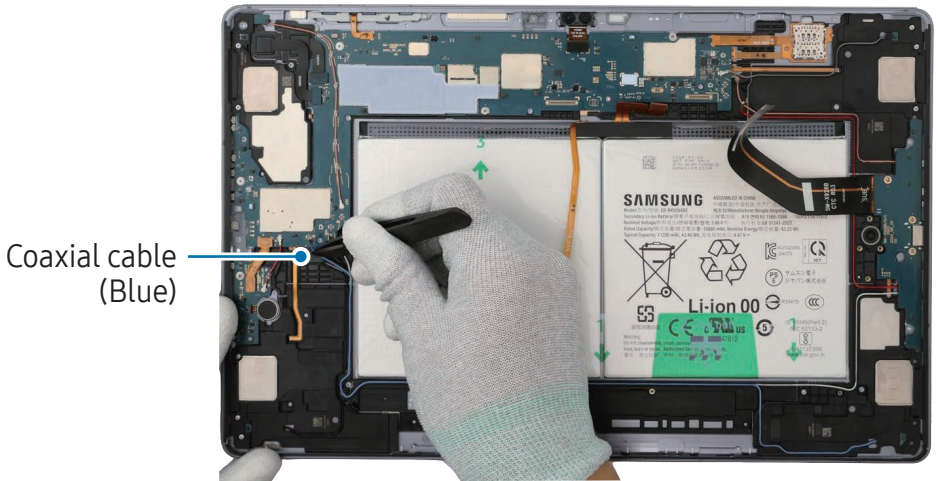
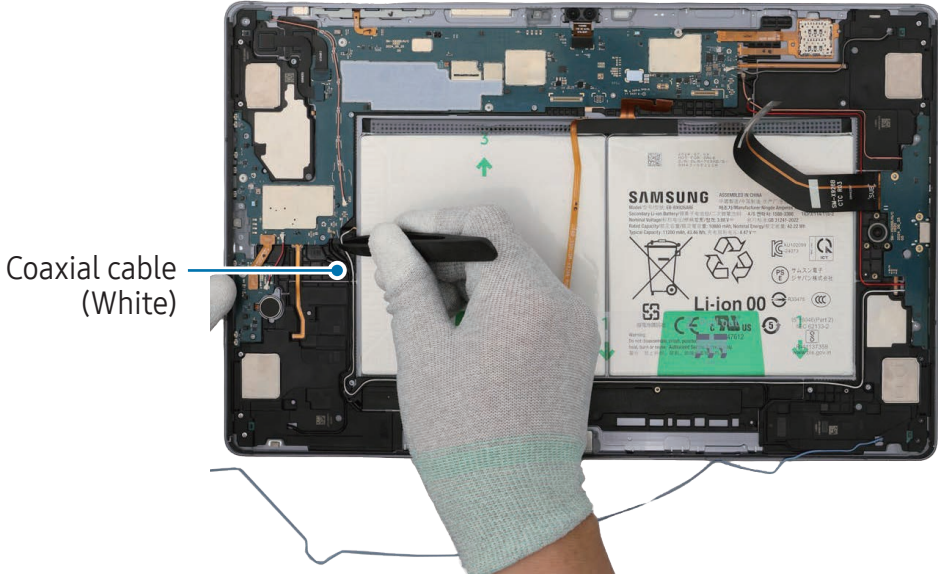

9 Check the screw 3443 (3 ea) and fasten them on the charging port using a cross-head screwdriver.

⚠ Be careful not to damage the charging port and near components.

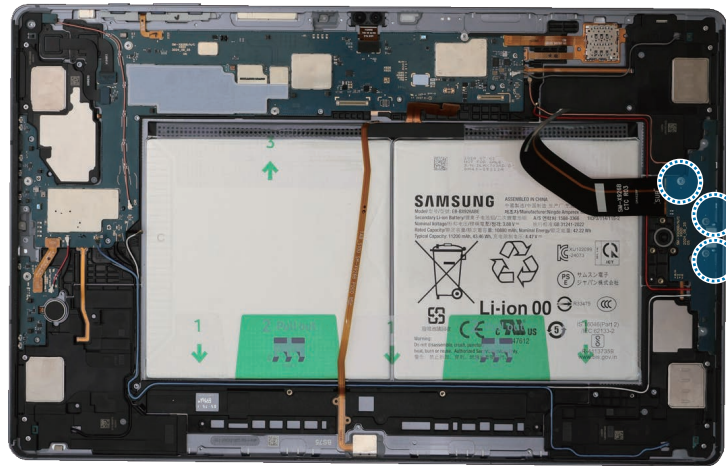

10 Check the screw 3405 (3 ea) and fasten it on the speaker using a cross-head screwdriver.

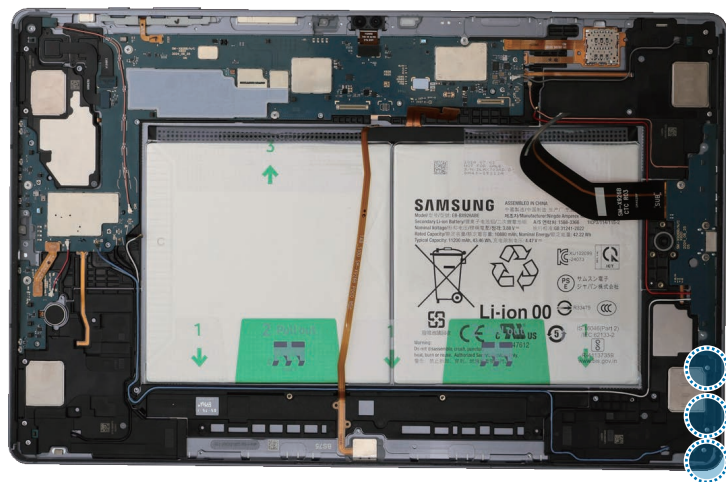

11 Using the tweezers, connect the 3 connectors and the coaxial cable connector (Black) to the main board. For the 5G or LTE devices, connect the additional 4 coaxial cable connectors (Blue/White/Orange/Red).



- Be careful not to damage the cable while connecting the connector.
- Be careful not to damage the near components.



- The 4 coaxial cables (Blue/White/Orange/Red) are only available for the 5G or LTE devices.
- The cables and connectors may vary depending on the country, region, or specifications.

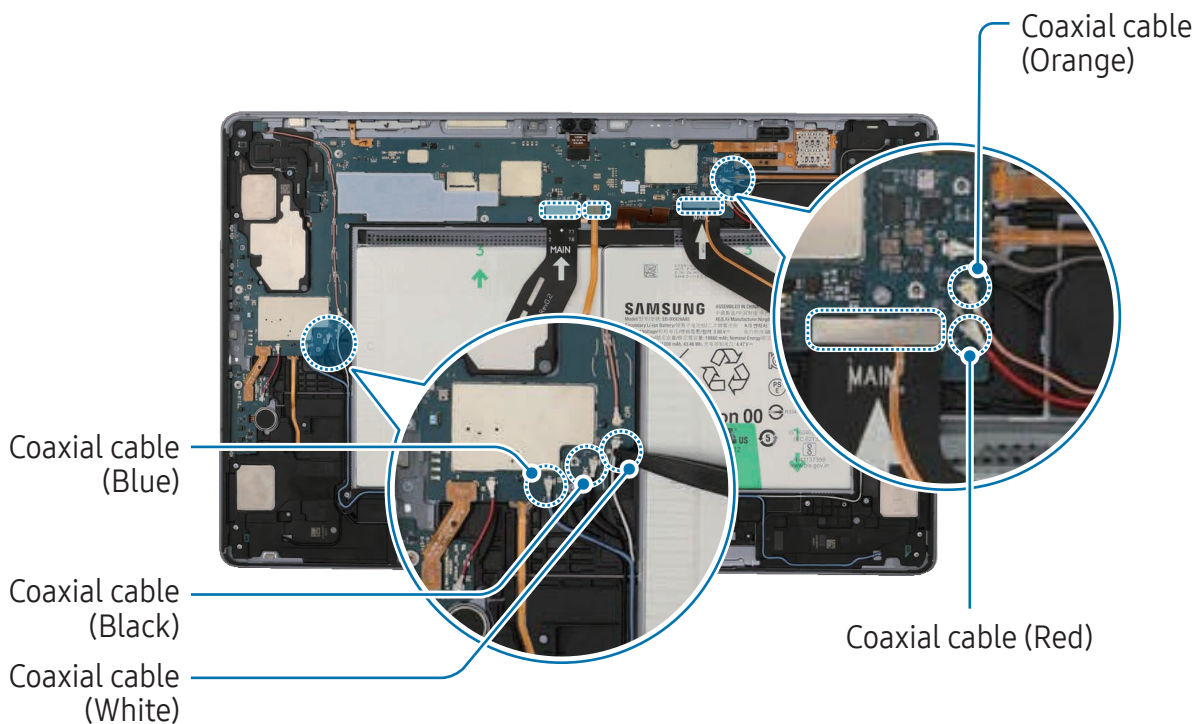
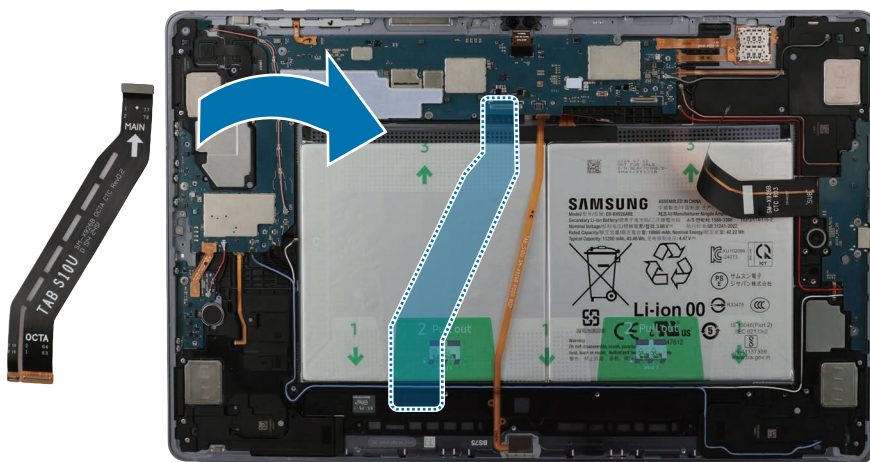

12 Connect the battery connector to the main board.

⚠ Be careful not to damage the battery.

⚠ Be careful not to damage the battery connector and near components.

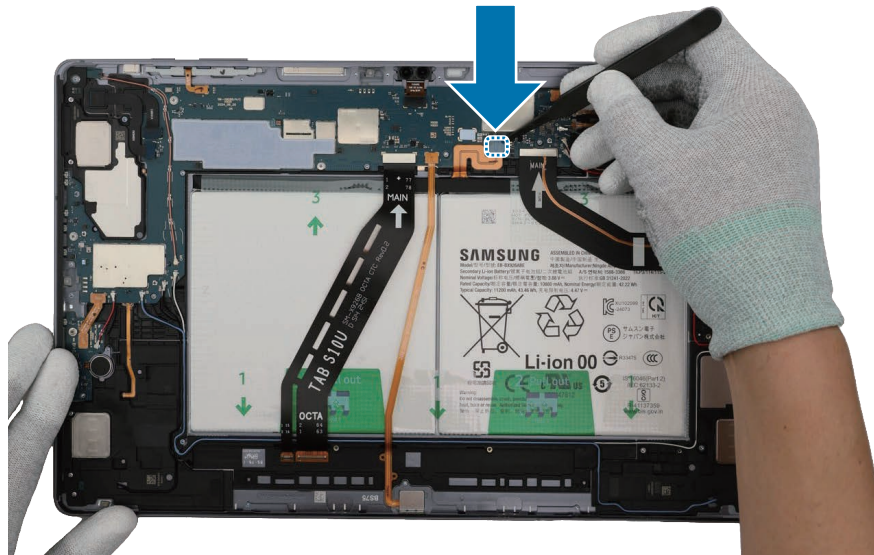

👉 Reassemble the **Bracket** and **Screen** to complete assembly.

Battery

- ⚠ • The battery can only be replaced at an authorised repair shop. If the battery is faulty, contact Samsung for further action.
- The separate battery may be damaged. Do not use it again.

Disassembly

- ✍ Remove the [Screen](#) and [Bracket](#) first before you begin.

1 Using the tweezers, disconnect the battery connector from the main board first. Separate the 3 connectors from the main board.

- ⚠ • Make sure to first disconnect the battery connector for your own safety.
- Be careful not to damage the battery.
- ⚠ • Be careful not to damage the cable while removing the connector.
- Be careful not to damage the near components.

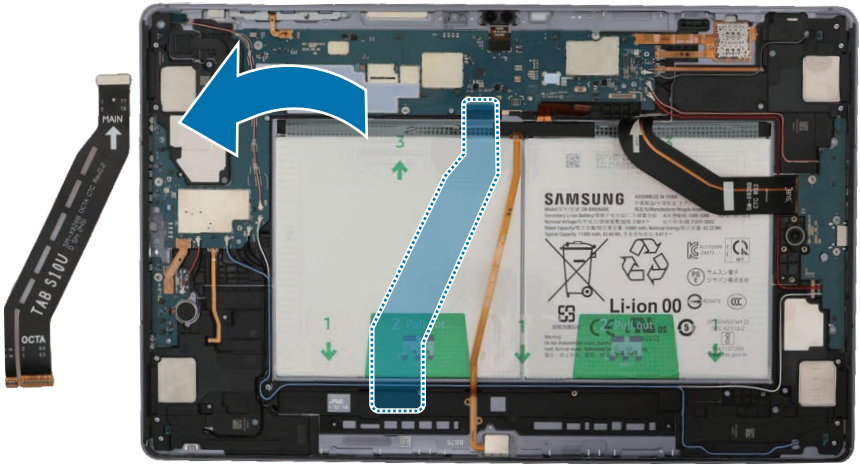
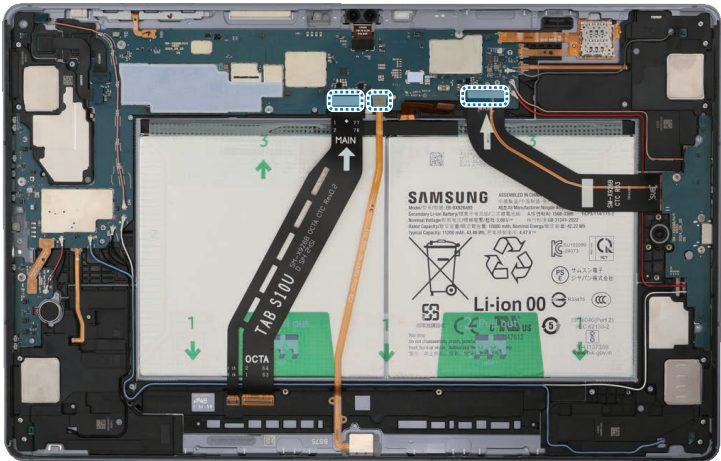
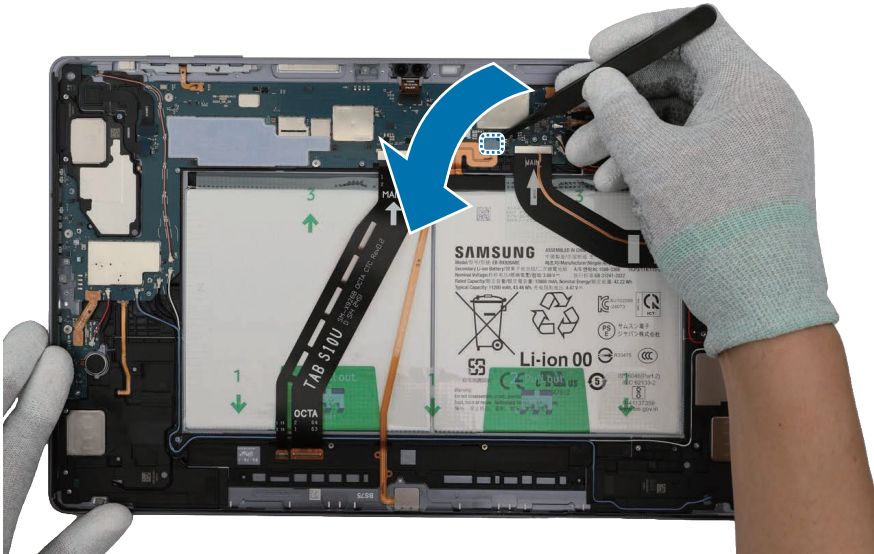

- Using your fingers, grab the tapes attached to the bottom of the battery and separate them carefully from the battery. Grab the tapes (marked as 2) with your fingers and pull it up one by one carefully. Slowly lift up the battery from the device and separate the bottom of the battery first. Using your fingers, hold the tapes (marked as 3) attached to the top of the battery and separate them from the battery. Grab the separated battery with your fingers and remove it completely from the device.



The separated battery may be damaged. Do not use it again.



- As the adhesive securing the battery is very strong, remove the battery slowly and carefully.
- The FPCB cables and connectors have to be positioned outside so as not to interfere when disassembling the battery.
- Be careful not to damage the connectors and near components.

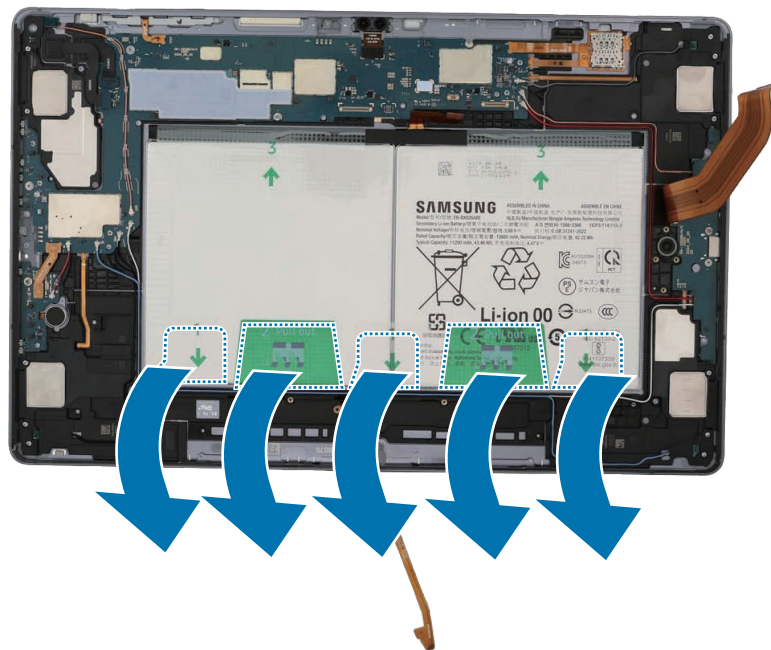

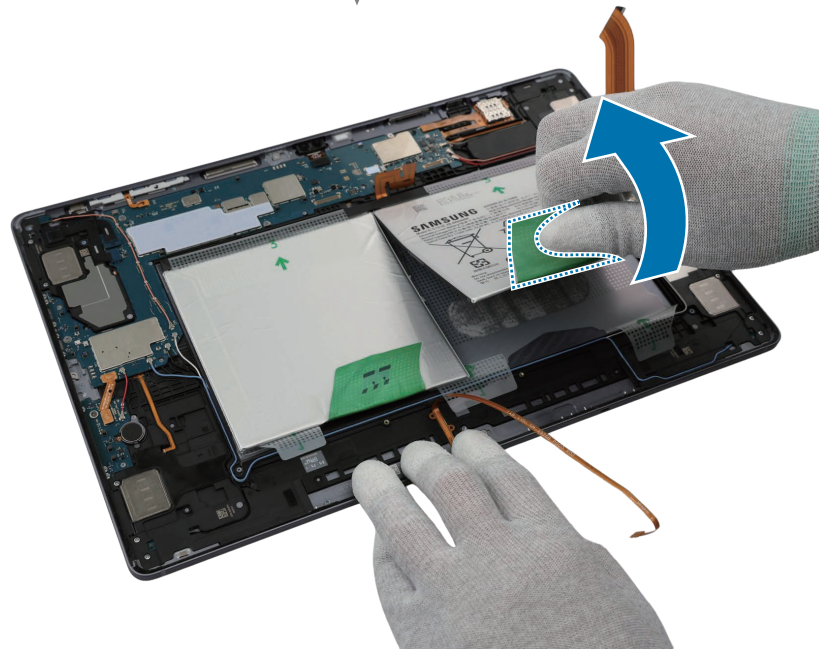
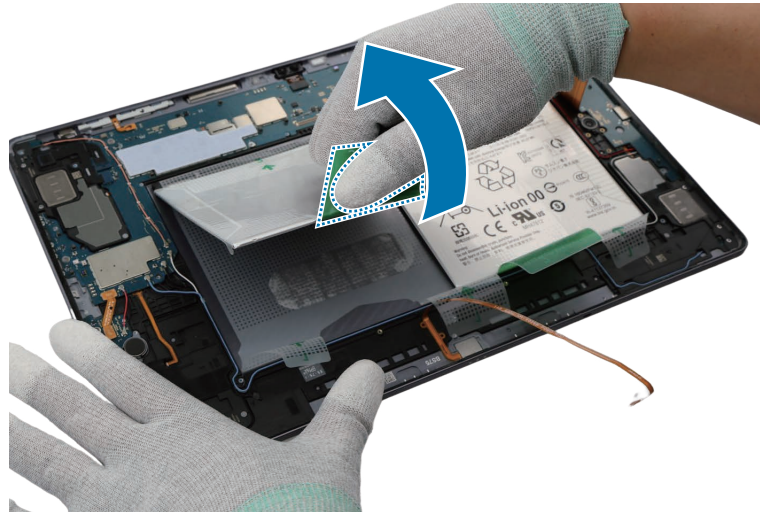

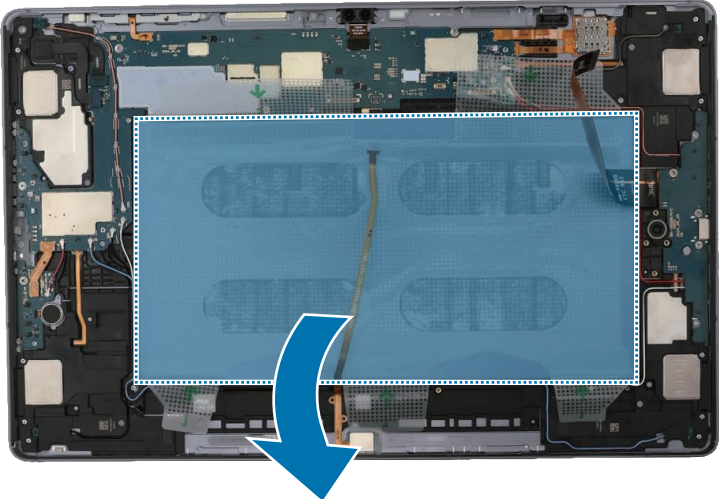
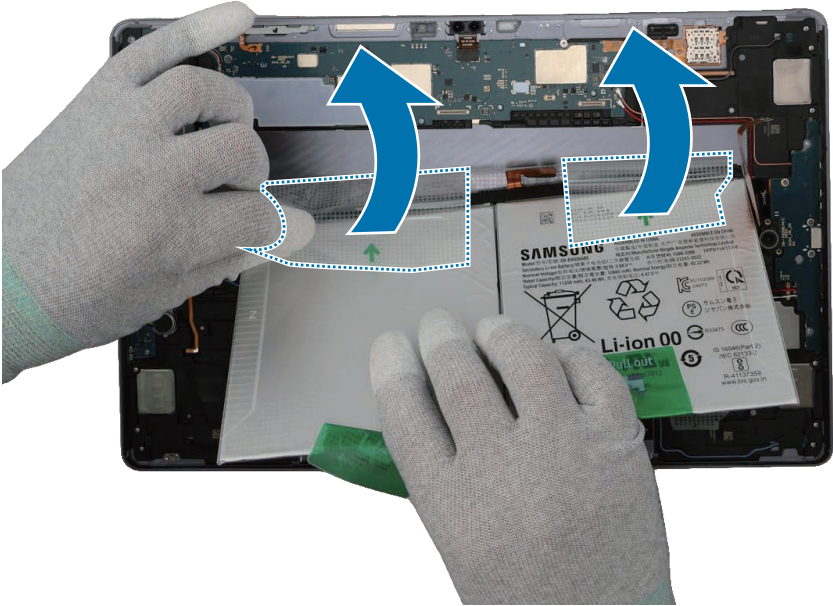

Reassembly

 Leaving screws inside the device may damage internal components, such as the battery. When assembling, be extra careful not to leave any unassembled screws inside the device.

- 1 Using your fingers, carefully separate the tape attached under the battery and lift it up slowly. Then, remove it completely from the device.

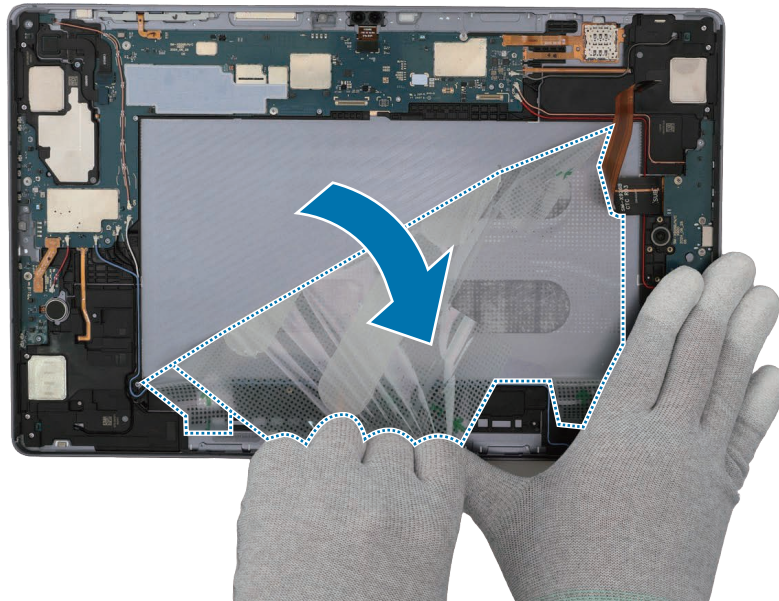

2 Using the tweezers, remove the remaining adhesive tapes from where the battery was attached.

- ⚠ • Make sure to remove any residual tapes attached to the inside of the back cover module before reassembling the new battery.
- Be careful not to damage the device and near components.

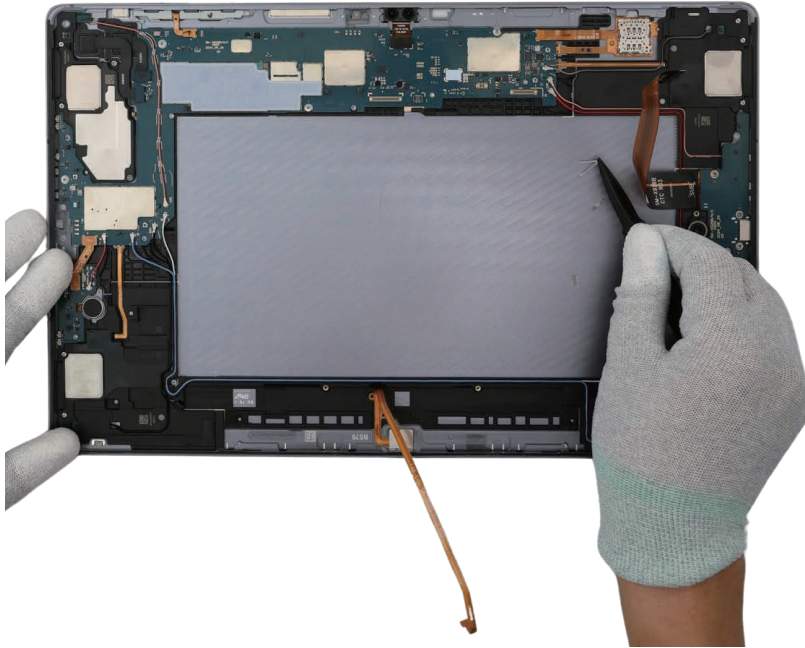

3 Using your fingers, carefully remove all release films from the new battery.

 Be careful not to damage the battery.

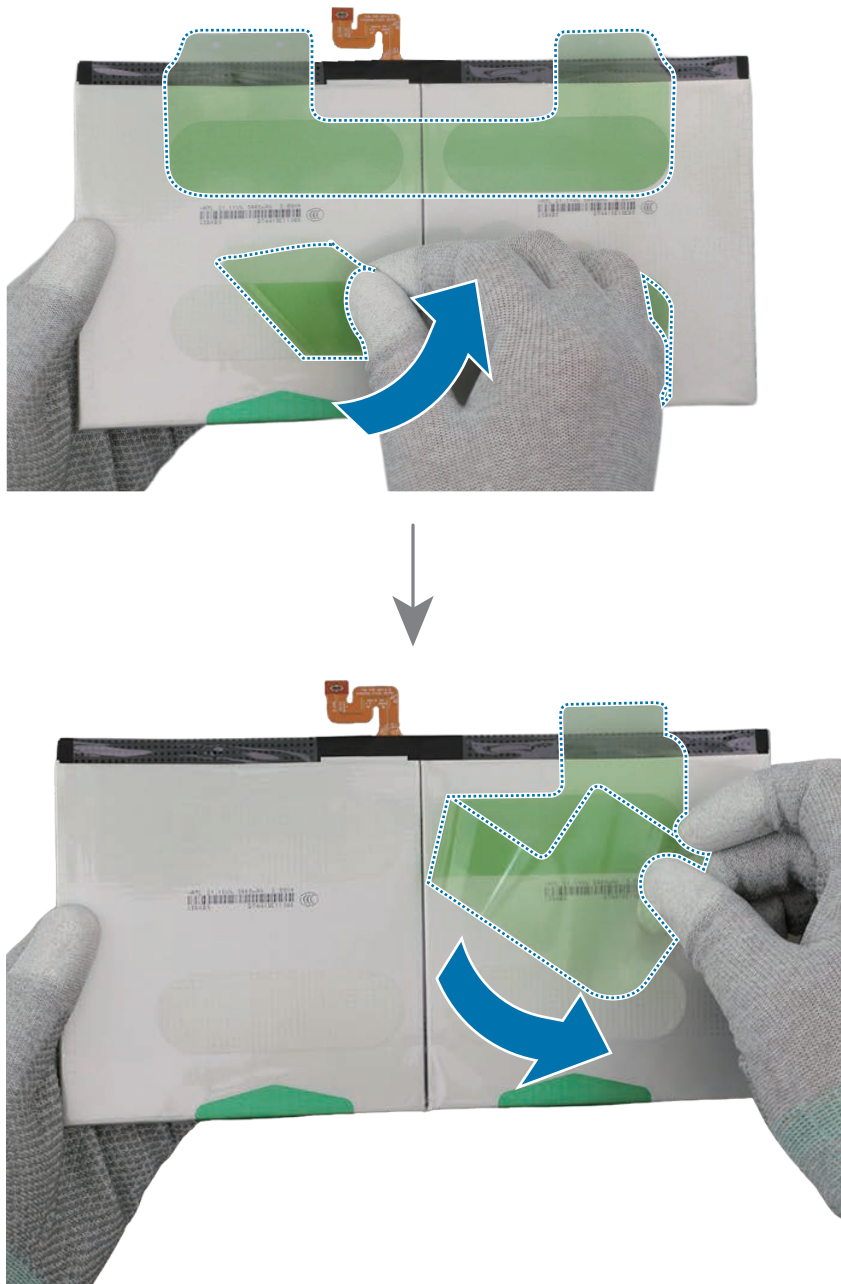

4 Before attaching the battery to the back cover module, connect the battery connector to the main board first using your fingers.

⚠ Be careful not to damage the battery.

⚠ Be careful not to damage the battery connector and near components.

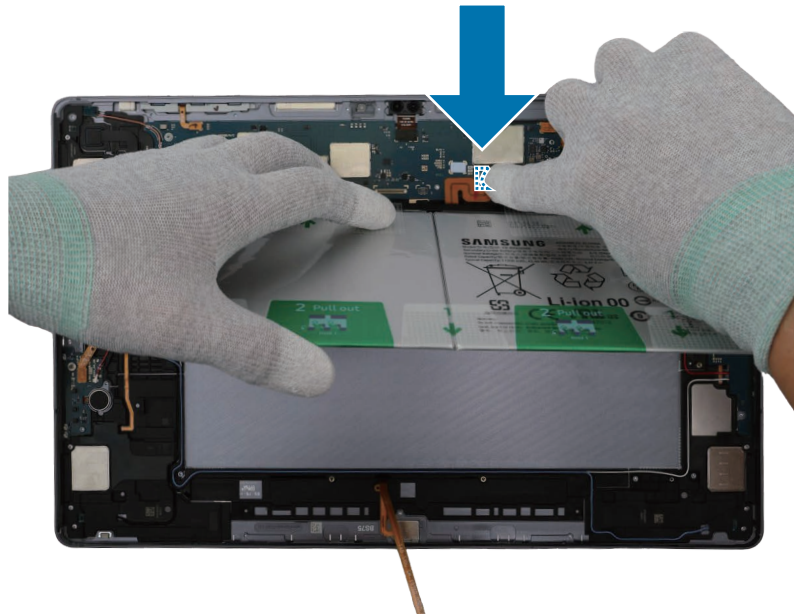

5 With the battery connector connected to the main board, assemble the battery in the correct position of the back cover module using your fingers.

⚠ • The FPCB cables have to be positioned outside so as not to interfere when assembling the battery.

• Be careful not to damage the near components.

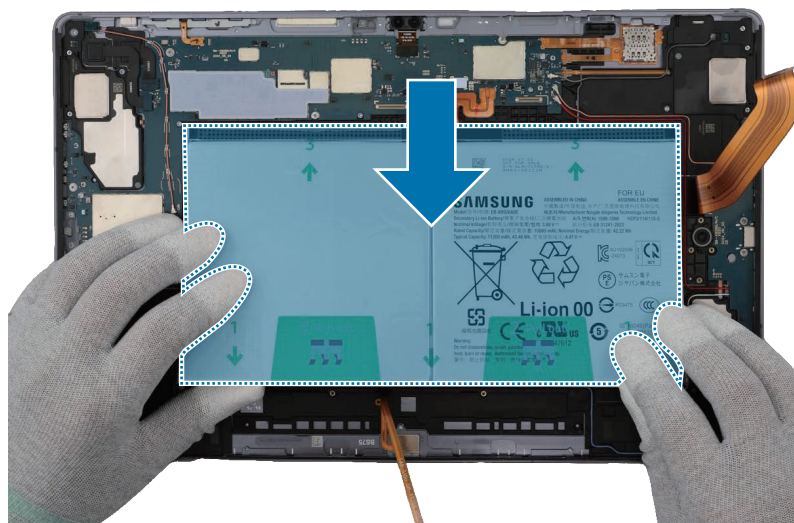

6 Press the battery with your fingers softly so that the battery can be attached well.

- The FPCB cables have to be positioned outside so as not to interfere when assembling the battery.
- Be careful not to damage the near components.

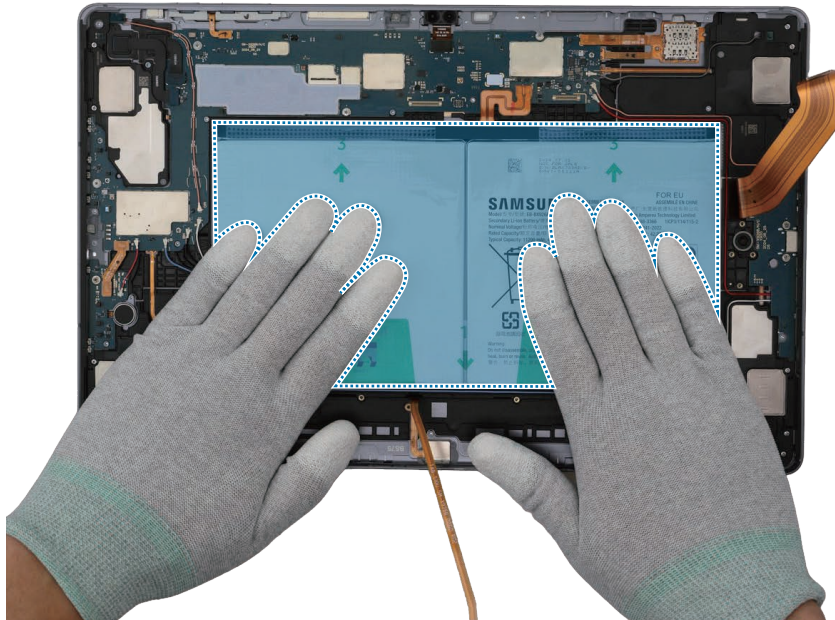

7 Using the tweezers, disconnect the battery connector from the main board.

- ⚠ • Make sure to first disconnect the battery connector for your own safety.
- Be careful not to damage the battery.

⚠ Be careful not to damage the battery connector and near components.

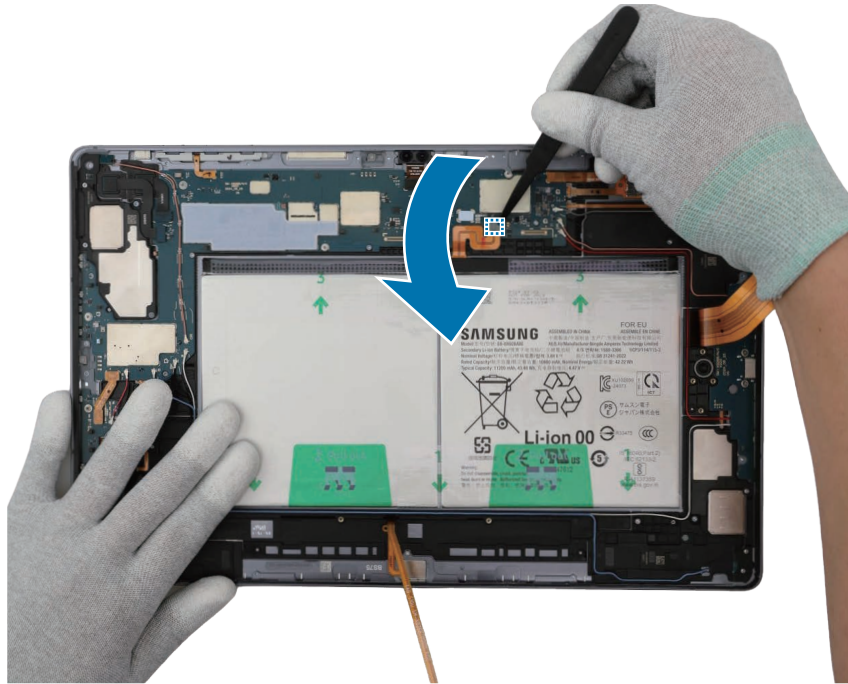

8 Now you can press the fully assembled battery using the press fixture. Remove the press fixture body and its handle from the rental tool kit packaging.

 Keep your hands out of the press fixture to avoid mechanical pinching and injury.

-  This tool is only available to use by the rental of tool kit that contains a complete set of the tools for self repair service.
- Availability of rental service may vary depending on the country and is currently available only in limited countries.
- A rented tool kit packaging may have different packaging than shown.

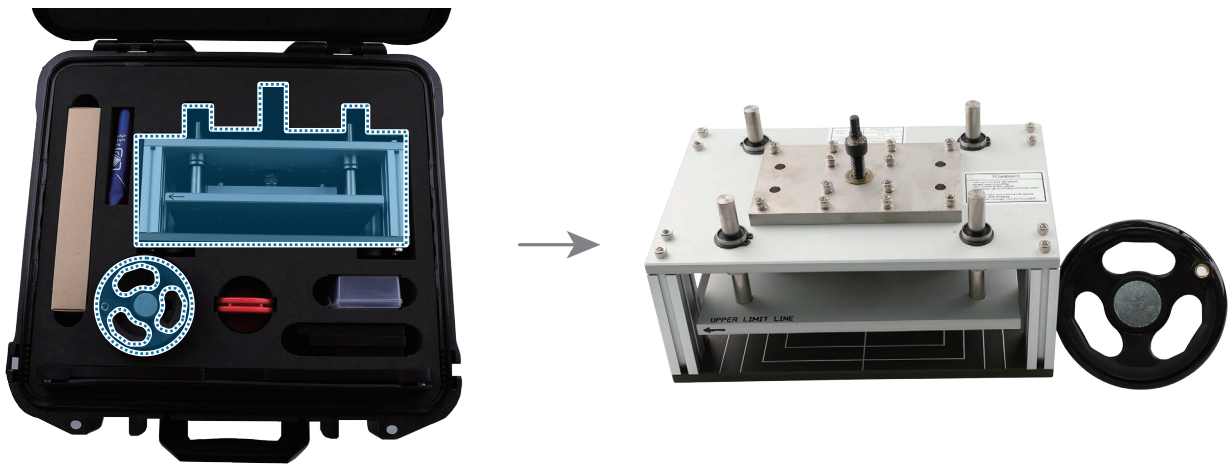

9 Carefully position the torque limit handle horizontally at the top of the press fixture.

 Keep your hands out of the press fixture to avoid mechanical pinching and injury.

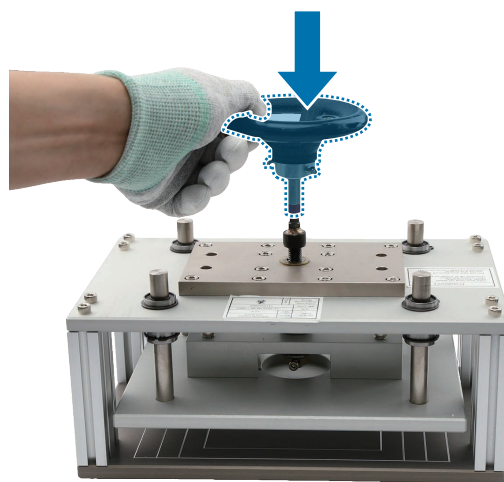

- 10 Remove the bottom press tray and the battery rubber pads (3 ea) from the rental tool kit packaging.

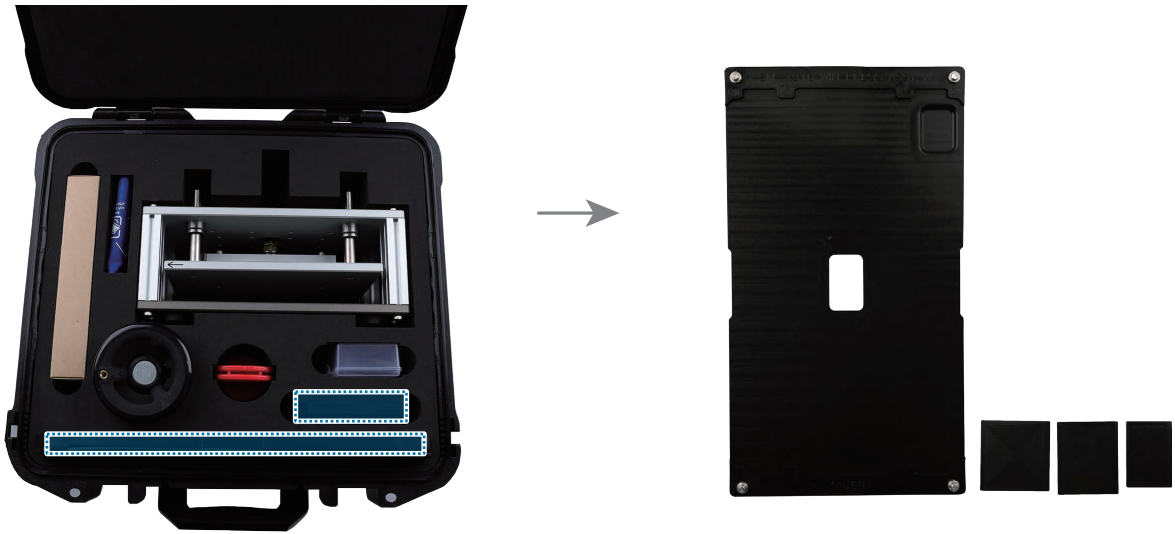

- 11 Place the screen facing down, and then place the device on the bottom press tray position.

 The model names on the press tray may vary.

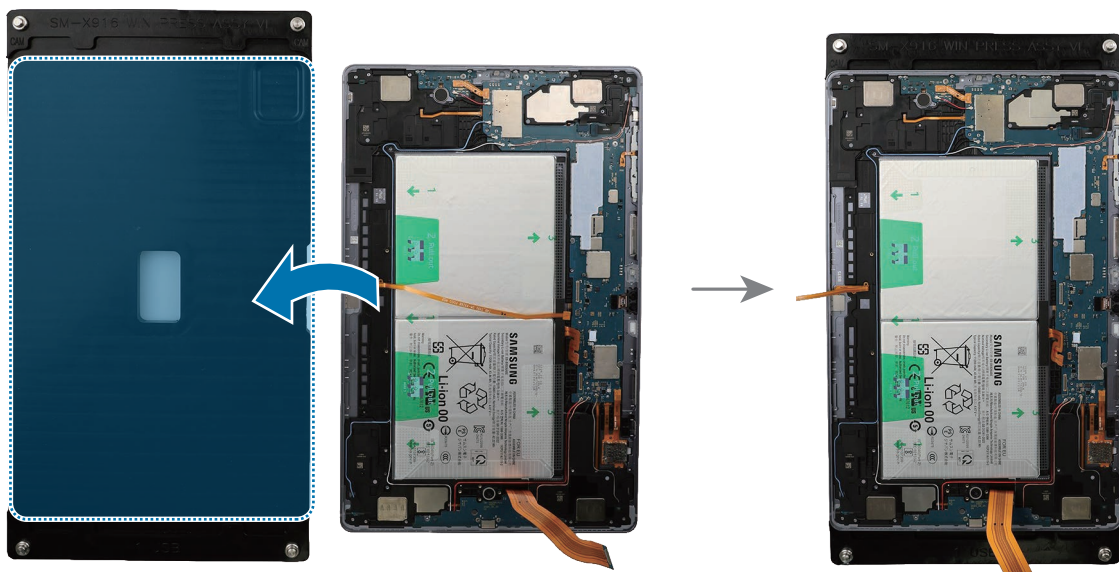

12 Choose a top battery-sized pad from the provided battery rubber pads and place it carefully on the top battery.

- ⚠ • Be careful not to cover the battery rubber pad beyond the battery size.
- The FPCB cables have to be positioned outside so as not to interfere when compressing the battery.

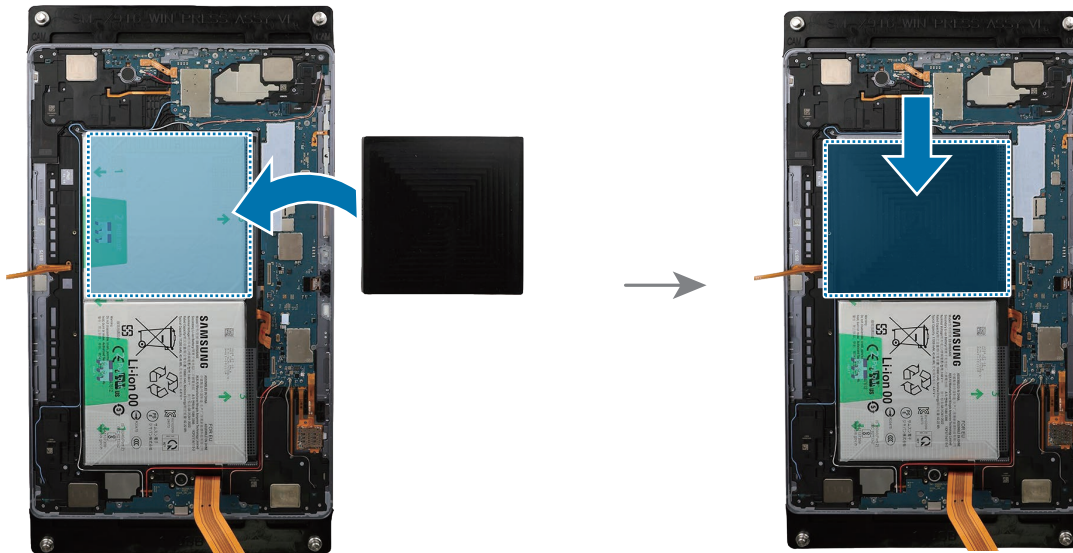

13 Position the top battery press tray in the centre of the press fixture.

- ⚠ Be careful not to move the battery pad out of its position.

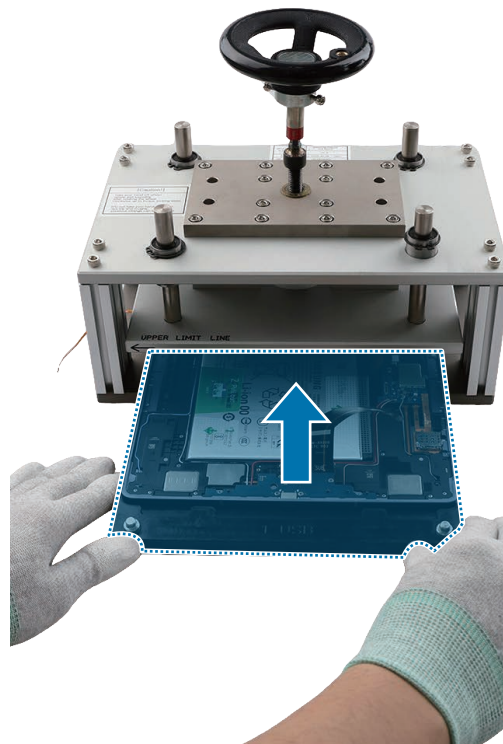

14 Rotate the torque limit handle to the clockwise until it makes a sound. In that press state, stay the tray for 5 seconds.

 Keep your hands out of the press fixture to avoid mechanical pinching and injury.

 When you reach the required maximum force (1 N), a sound is made from the handle if you turn the handle.

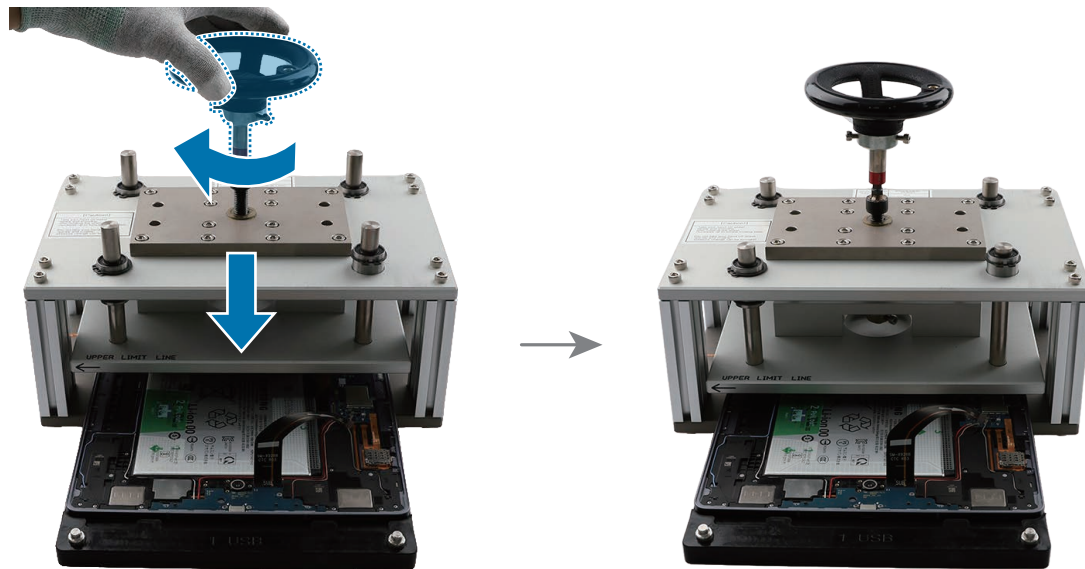

15 When the press is completed after 5 seconds, rotate the torque limit handle to the anticlockwise and remove the tray from the press fixture.

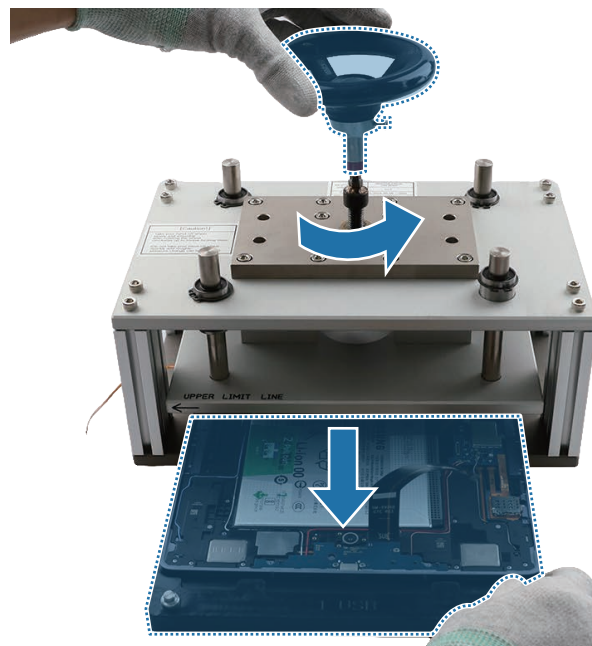

16 Place the battery rubber pad carefully on the bottom battery.

- ⚠ Be careful not to cover the battery rubber pad beyond the battery size.
- The FPCB cables have to be positioned outside so as not to interfere when compressing the battery.

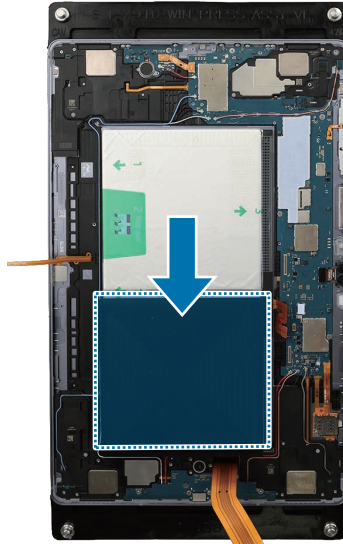

17 Position the bottom battery press tray in the centre of the press fixture.

- ⚠ Be careful not to move the battery pad out of its position.

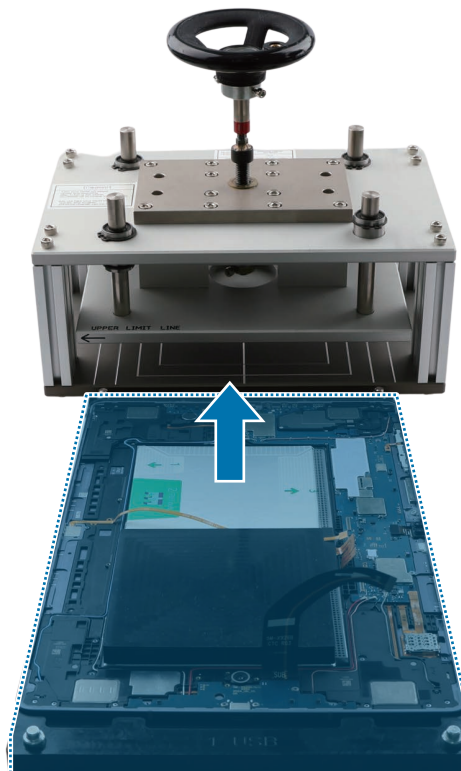

18 Rotate the torque limit handle to the clockwise until it makes a sound. In that press state, stay the tray for 5 seconds.

 Keep your hands out of the press fixture to avoid mechanical pinching and injury.

 When you reach the required maximum force (1 N), a sound is made from the handle if you turn the handle.

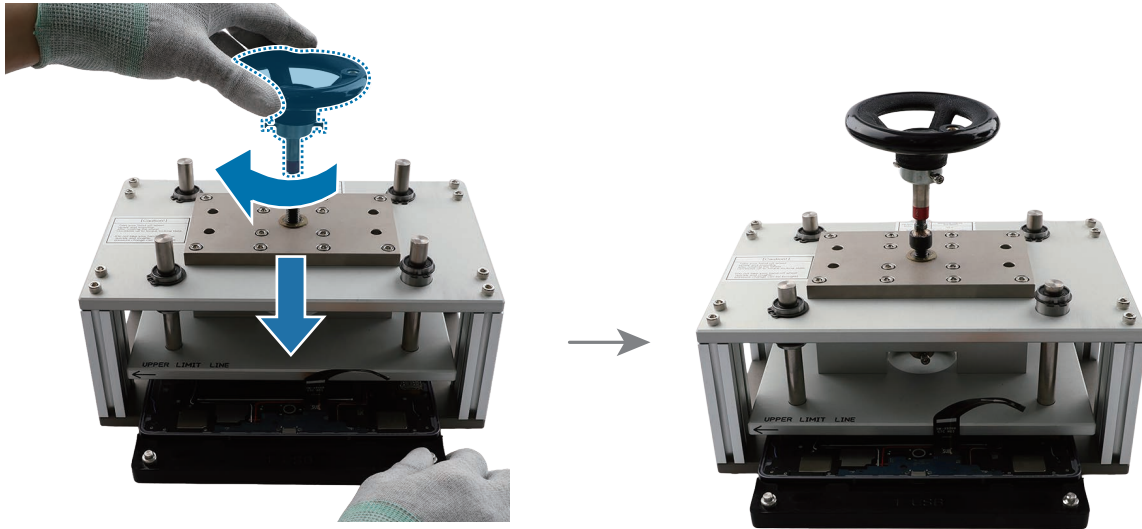

19 When the press is completed after 5 seconds, rotate the torque limit handle to the anticlockwise and remove the tray from the press fixture.

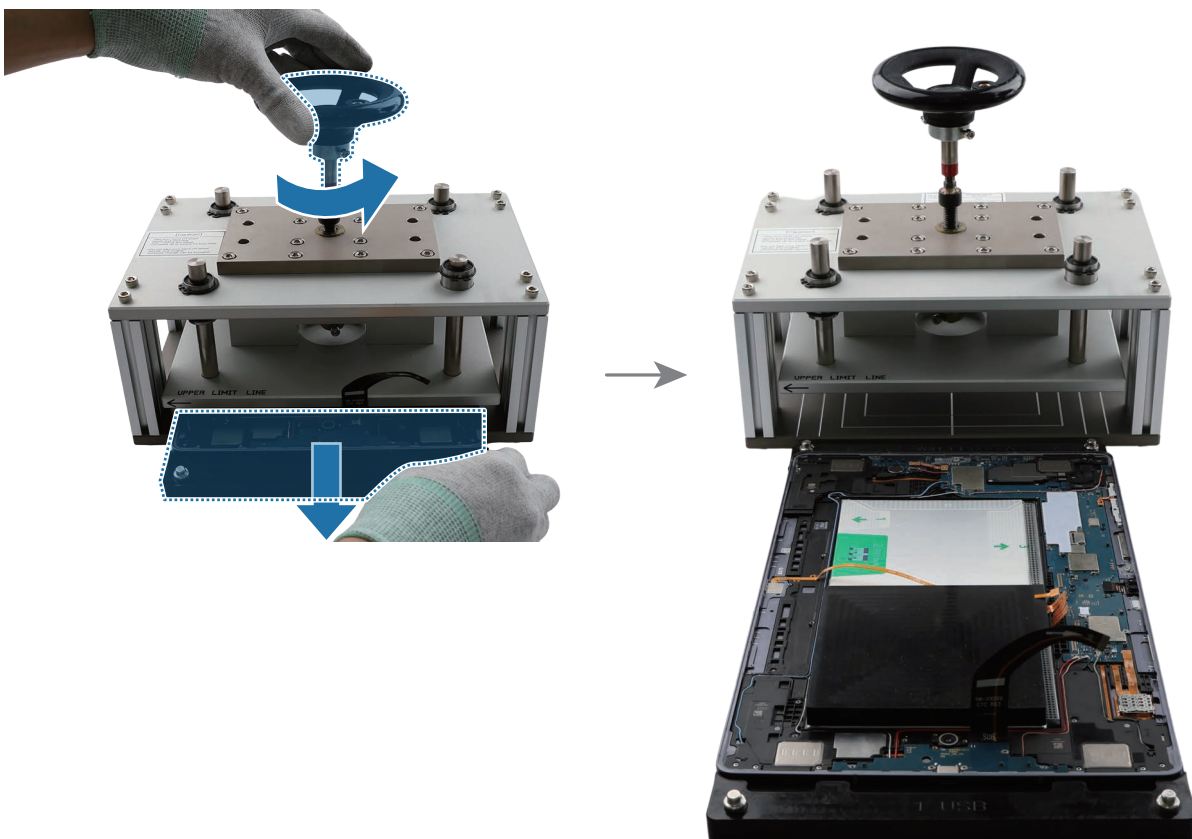

20 Remove the device and the rubber pad carefully from the tray.

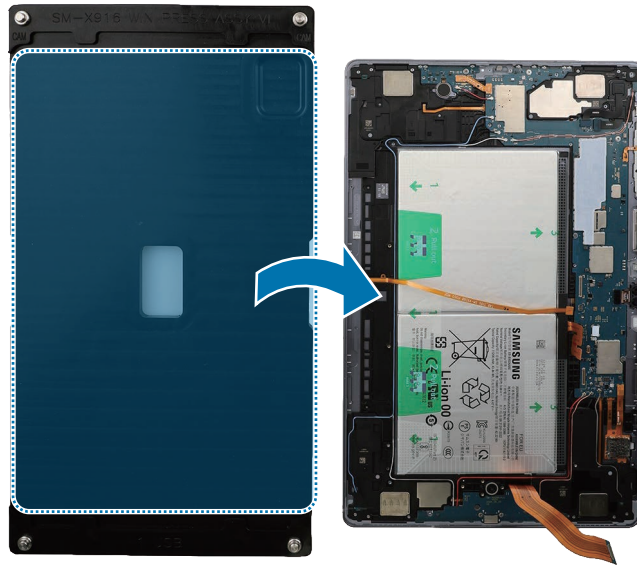

22 Using the tweezers, connect the battery connector to the main board.

⚠ Be careful not to damage the battery.

⚠ Be careful not to damage the battery connector and near components.

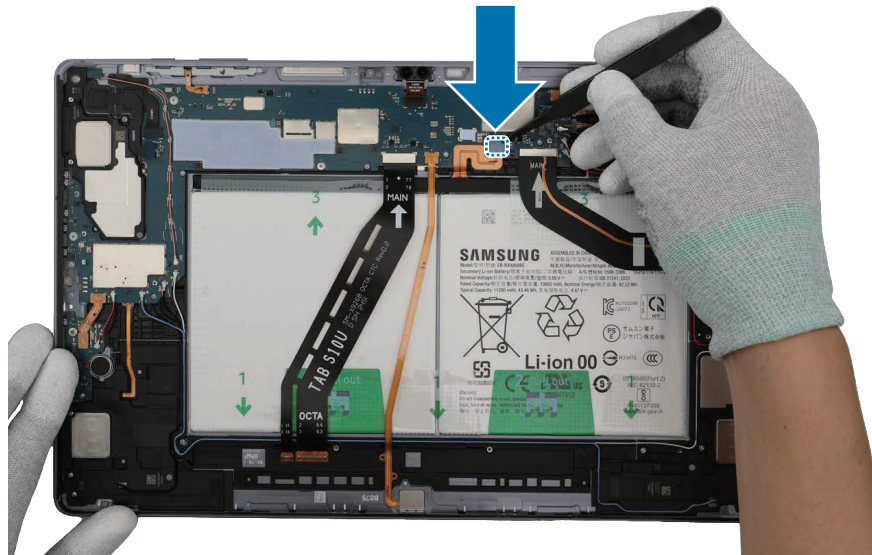



👉 Reassemble **Bracket** and **Screen** to complete assembly.

Button

-  The buttons are already built into the back cover module. Disassemble the buttons only if the buttons themselves require repairs.

Disassembly

To remove the Volume button or Side button, lightly press one end of the button with your fingers so that the other end protrudes. Push the tip of the protruding button up carefully with the round-tip metal tweezers and lift it up until you can grab it with your fingers. Grab the button with your fingers and pull it out carefully from the device.

-  When holding the buttons with the tweezers, be careful not to damage or scratch the device.
-  If you have trouble separating the buttons with your tweezers, please try using a sharper and thinner tool.

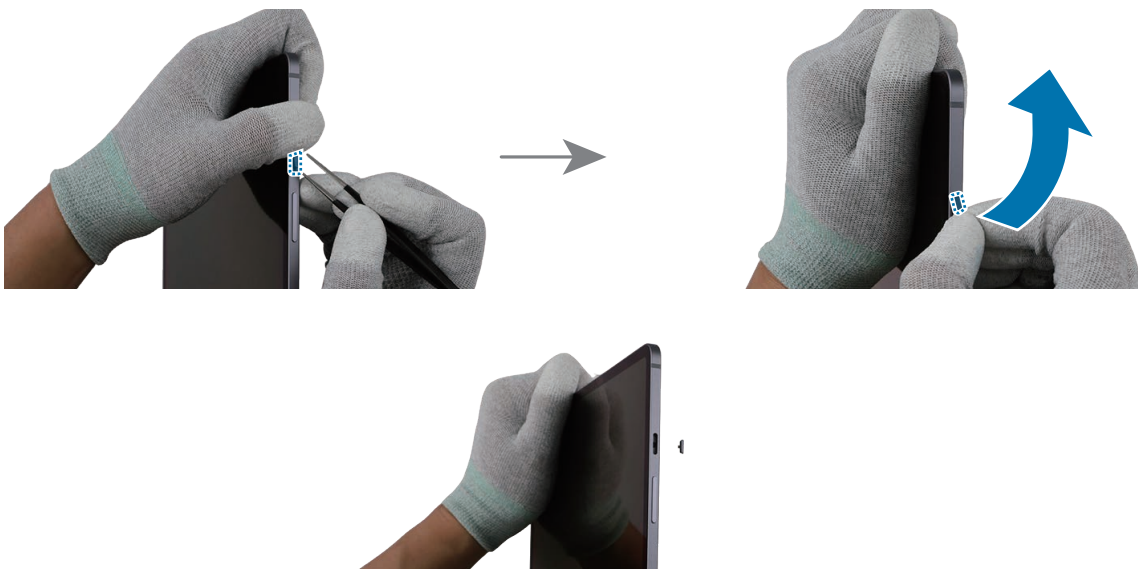

Disassembly and Assembly

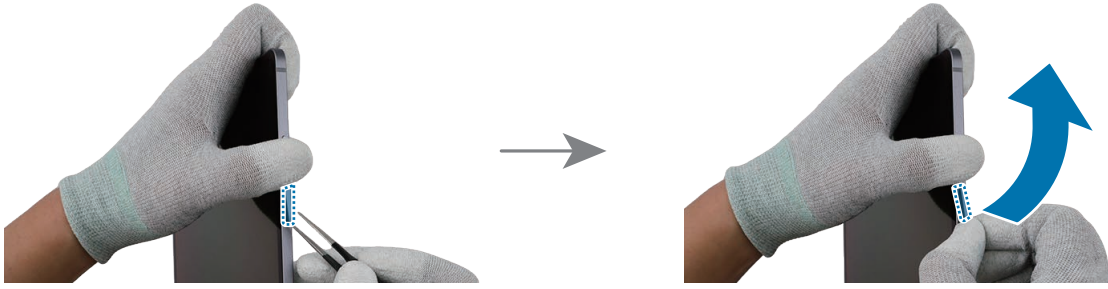

Reassembly

 Leaving screws inside the device may damage internal components, such as the battery. During assembly, be extra careful not to leave any unassembled screws inside the device.

1 Remove the release film of a new Volume button. Using your fingers, grab the Volume button and insert it on the slot carefully.

-  Be careful not to damage the button and device.
- Be careful not to put the button in the wrong direction.



2 Press down the Volume button softly and evenly so that the button can be completely assembled. Press the button to make sure it clicks. It should have the same sound and feel as before disassembly.



3 Remove the release film of a new Side button. Using your fingers, grab the Side button and insert it on the slot carefully.

- ⚠ • Be careful not to damage the button and device.
- Be careful not to put the button in the wrong direction.



4 Press down the Side button softly and evenly so that the button can be completely assembled. Press the button to make sure it clicks. It should have the same sound and feel as before disassembly.



Back Cover

Disassembly



Remove the [SIM Card Tray](#), [Screen](#) and [Bracket](#) first before you begin.

1 Using the tweezers, disconnect the battery connector from the main board first. Separate the 8 connectors and the 3 coaxial cable connectors (Orange/Black/Red) from the main board. For the 5G or LTE devices, separate the additional 5 coaxial cable connectors (Blue/White/Grey/Orange/Red).



- Make sure to first disconnect the battery connector for your own safety.
- Be careful not to damage the battery.



- Be careful not to damage the cable while removing the connector.
- Be careful not to damage the near components.



- The 5 coaxial cables (Blue/White/Grey/Orange/Red) are only available for the 5G or LTE devices.
- The cables and connectors may vary depending on the country, region, or specifications.

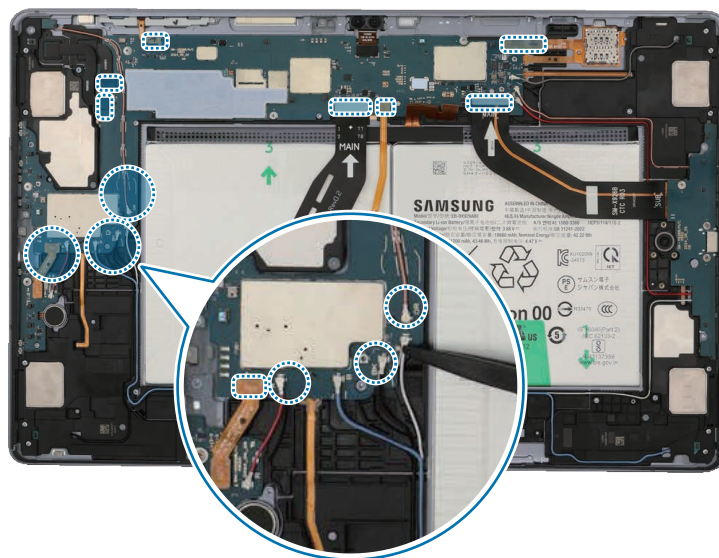
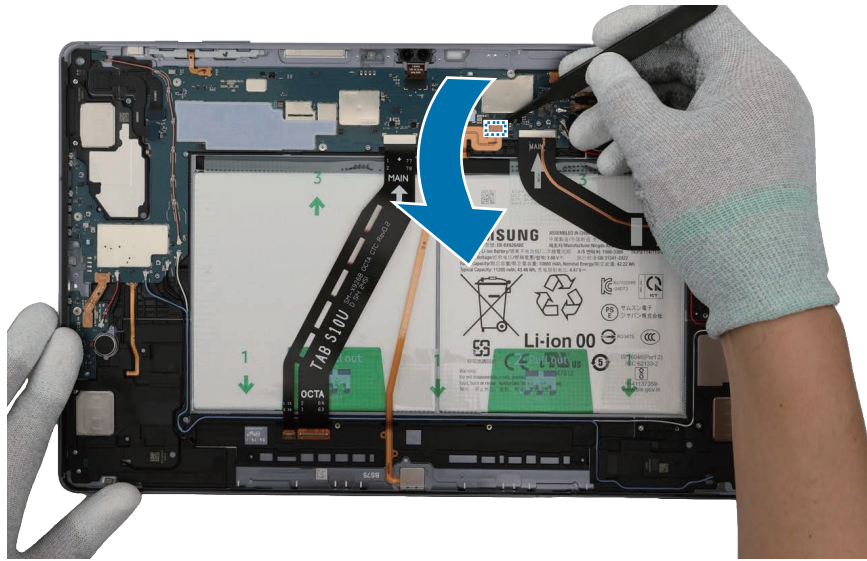

Disassembly and Assembly

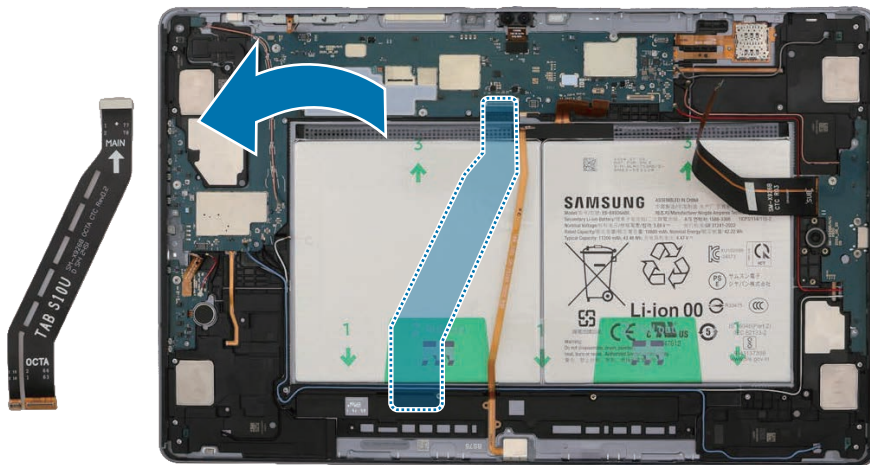
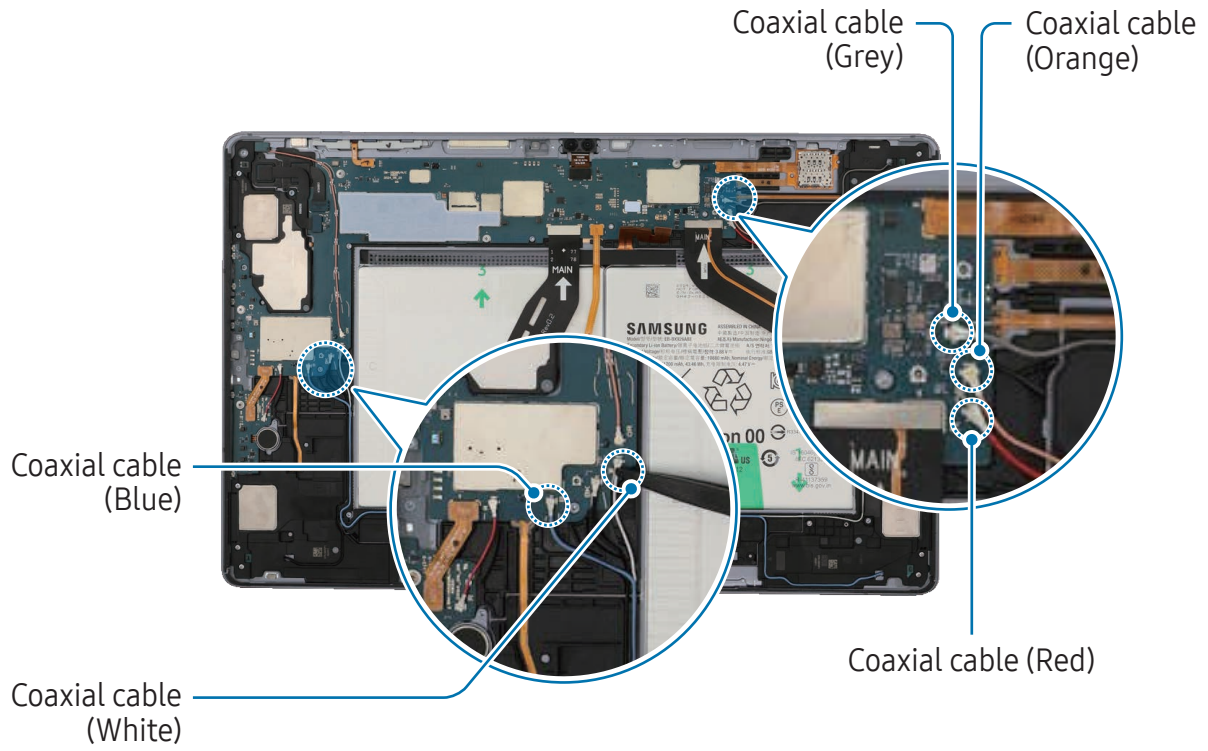

2 Check and remove the screws at the 4 different points on the main board using a cross-head screwdriver.

⚠ Be careful not to damage the main board and near components.

✓ Check the number of screws that have been removed, and store them carefully to make sure that no unassembled screws are left inside the device during assembly.

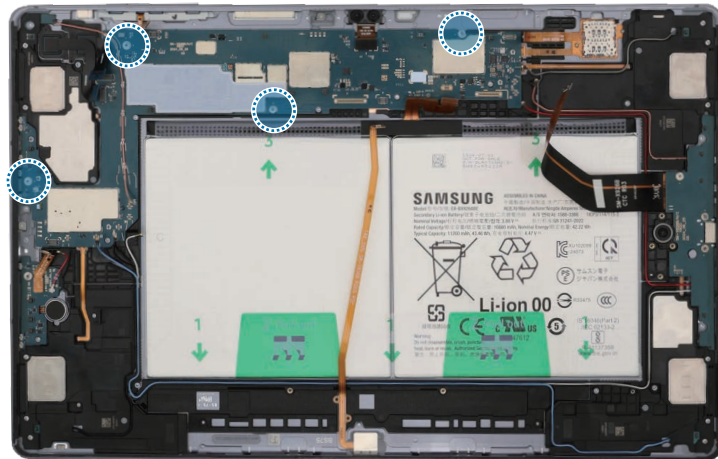

3 Using the tweezers, disconnect the coaxial cable (Orange) from the main board. Then, lift up on the separator groove of the main board and remove the main board module.

- ⚠ • Be careful not to damage the battery connector, the main board and near components.
- The cables have to be positioned outside so as not to interfere when disassembling the main board.

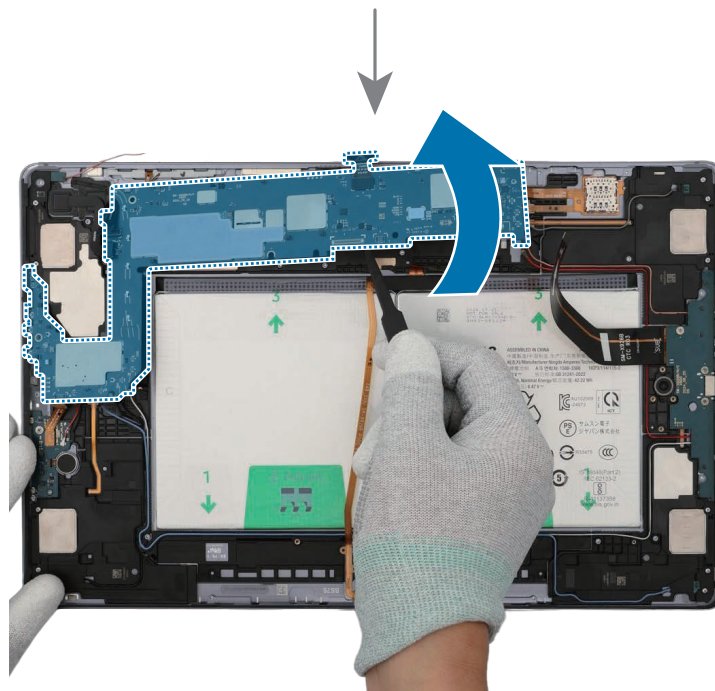

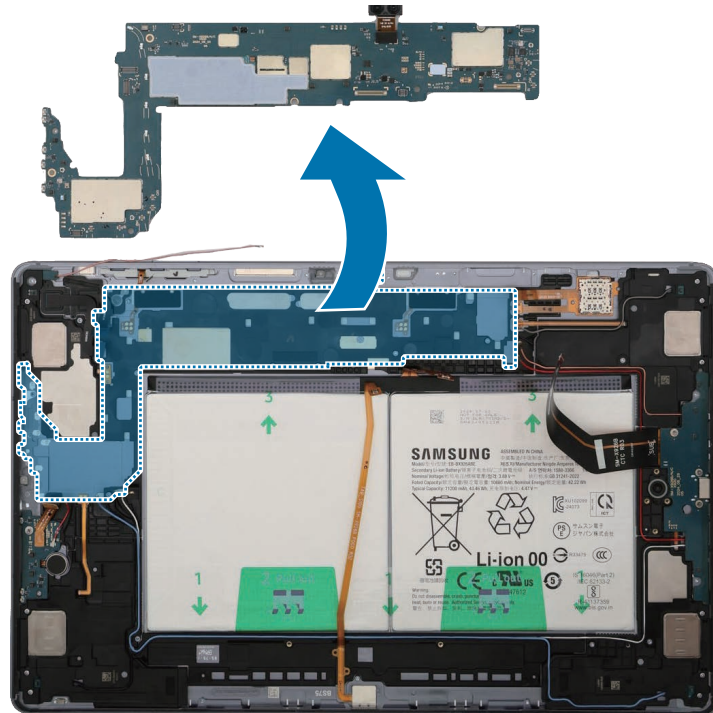

4 Using the tweezers, lift up on the separator groove of the ultra wide camera first and remove it. Leave the camera lens facing up.



- Be careful not to touch the camera lens while removing the camera.
- Be careful not to damage the camera and near components.

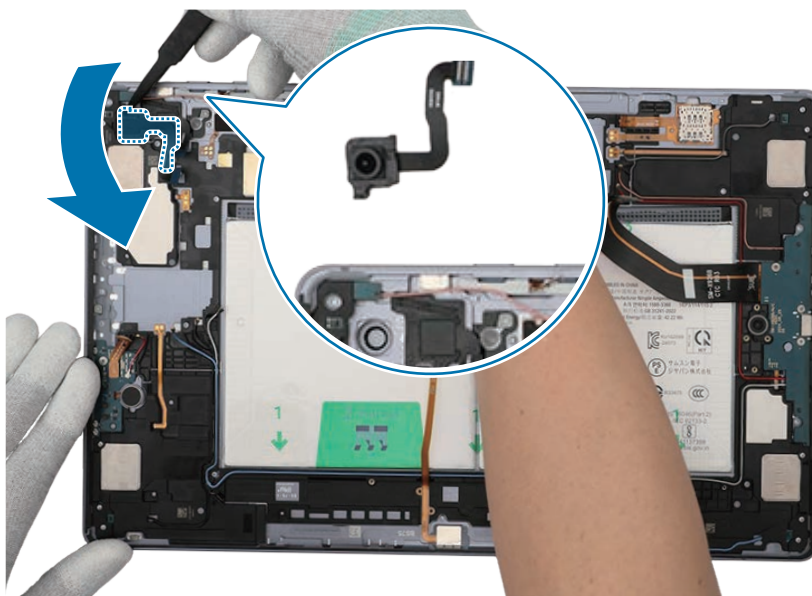

5 Using the tweezers, lift up on the separator groove of the wide camera and remove it. Leave the camera lens facing up.

- ❗ • Be careful not to touch the camera lens while removing the camera.
- Be careful not to damage the camera and near components.

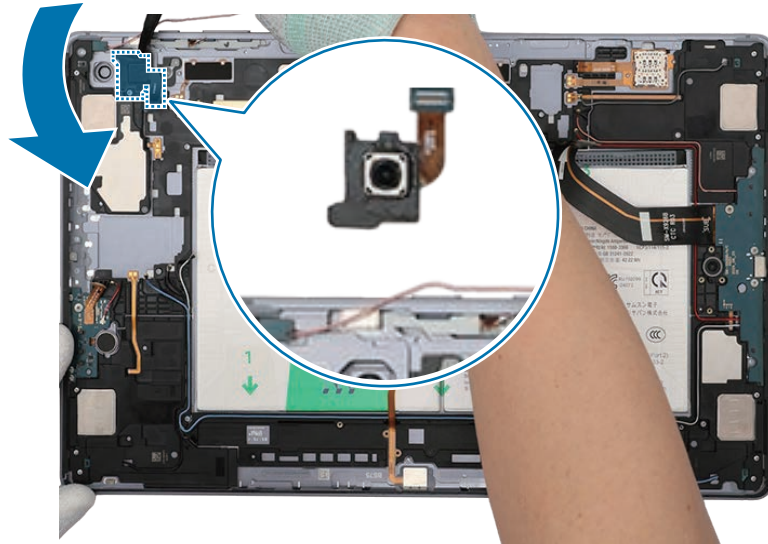

6 Check the screws at the 3 different points on the charging port and remove them using a cross-head screwdriver.

- ❗ Be careful not to damage the charging port and near components.
- ✔ Check the number of screws that have been removed, and store them carefully to make sure that no unassembled screws are left inside the device during assembly.

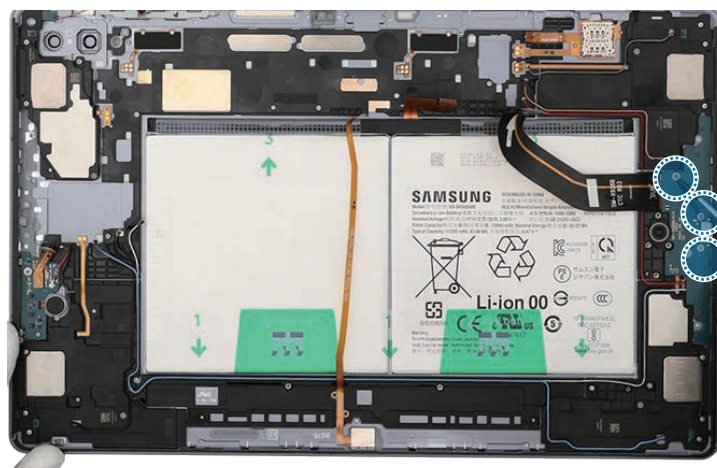

7 For the 5G or LTE devices, disconnect the 4 coaxial cables (Blue/White/Orange/Red) in the speaker modules with the tweezers. Using the tweezers, lift up on the separator groove of the charging port module, and remove it carefully.

- ⚠ • Check the position of the overlapping cables and disconnect them in order from the top.
- Be careful not to damage the cables and near components.
- 📄 • The 4 coaxial cables (Blue/White/Orange/Red) are only available for the 5G or LTE devices.
- The cables and connectors may vary depending on the country, region, or specifications.

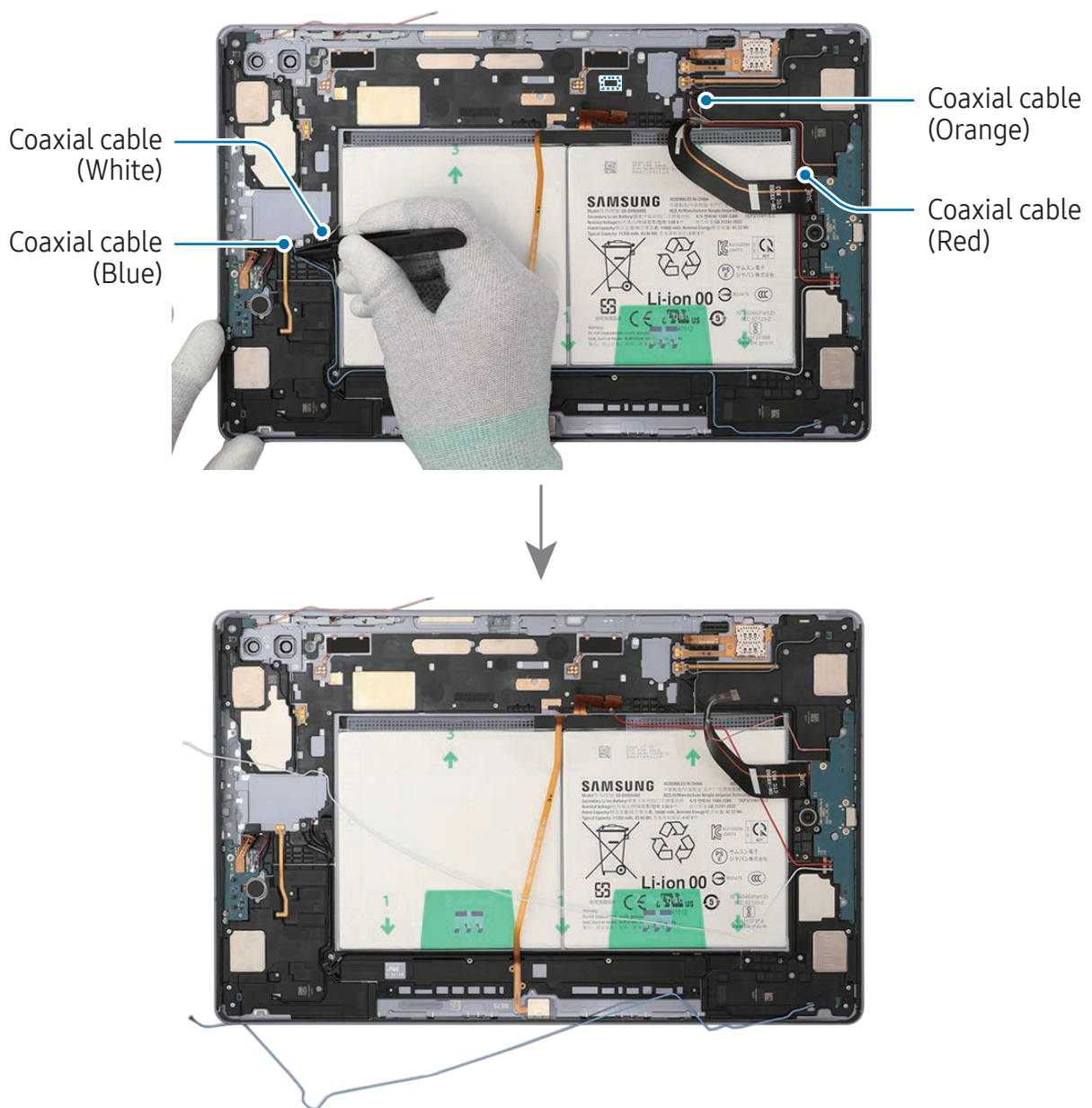

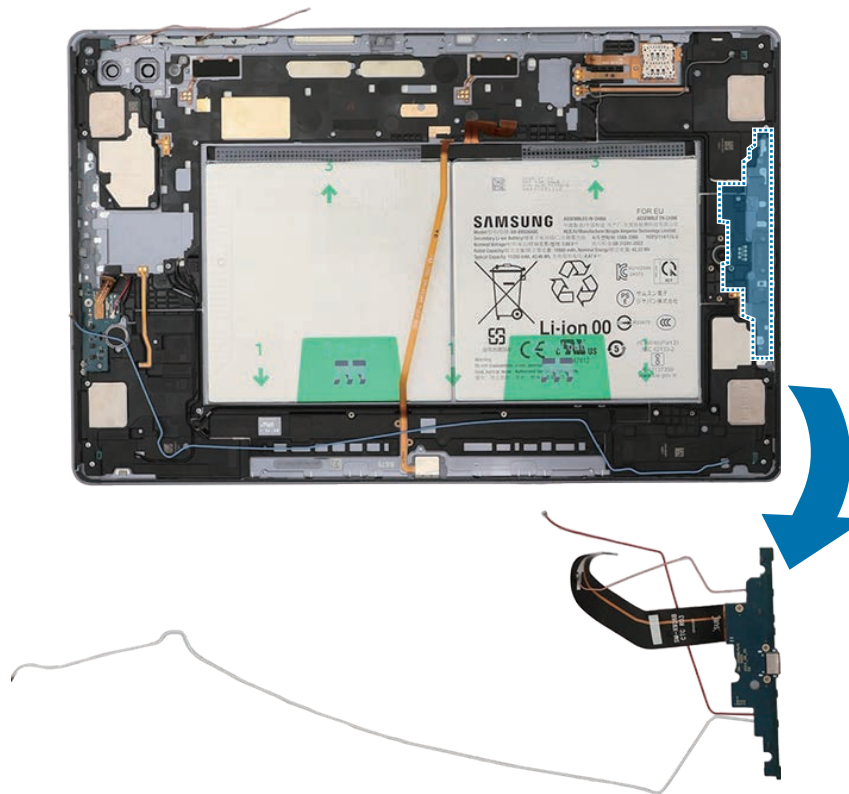
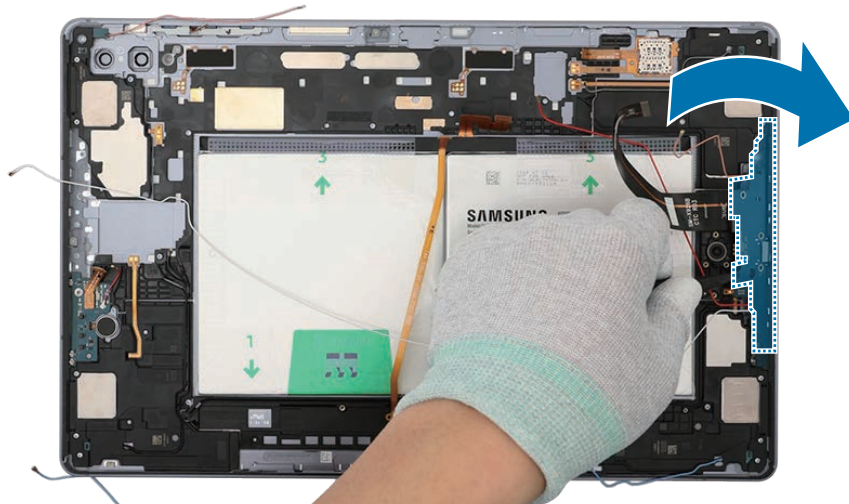

8 Check the screw on the Wi-Fi board and remove it using a cross-head screwdriver.

⚠ Be careful not to damage the near components.

📝 Check the number of screws that have been removed, and store them carefully to make sure that no unassembled screws are left inside the device during assembly.

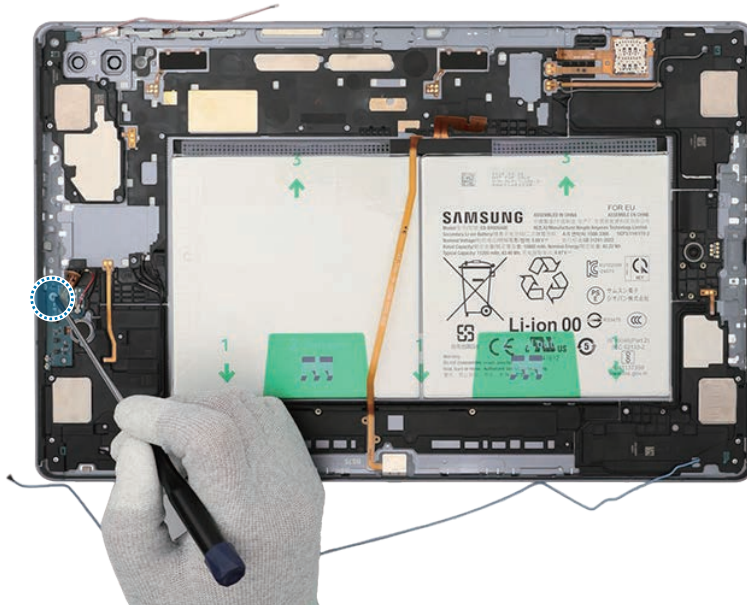

9 Using the tweezers, lift up the Wi-Fi board from the back cover module and remove it.

⚠ Be careful not to damage the cables and near components.

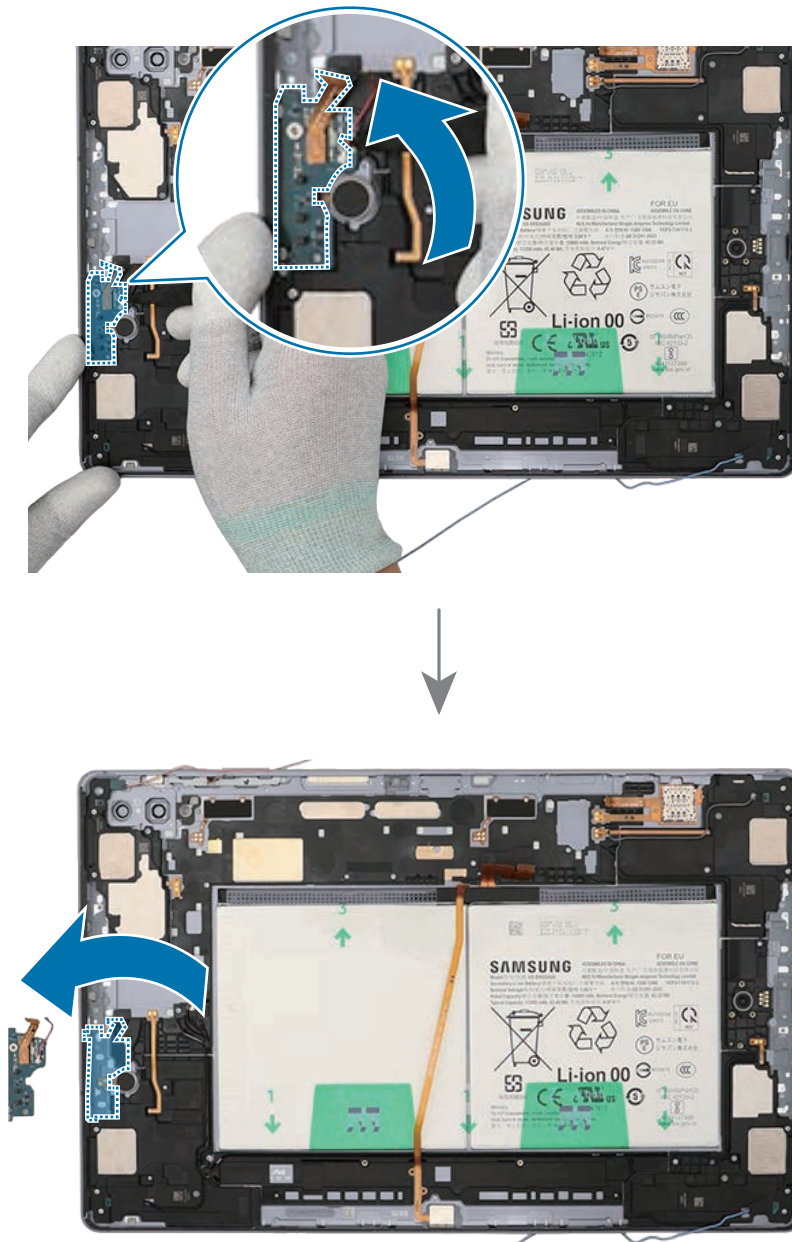

10 Check the screws at the 3 different points on the speaker1 and remove them using a cross-head screwdriver.

⚠ Be careful not to damage the near components.

📝 Check the number of screws that have been removed, and store them carefully to make sure that no unassembled screws are left inside the device during assembly.

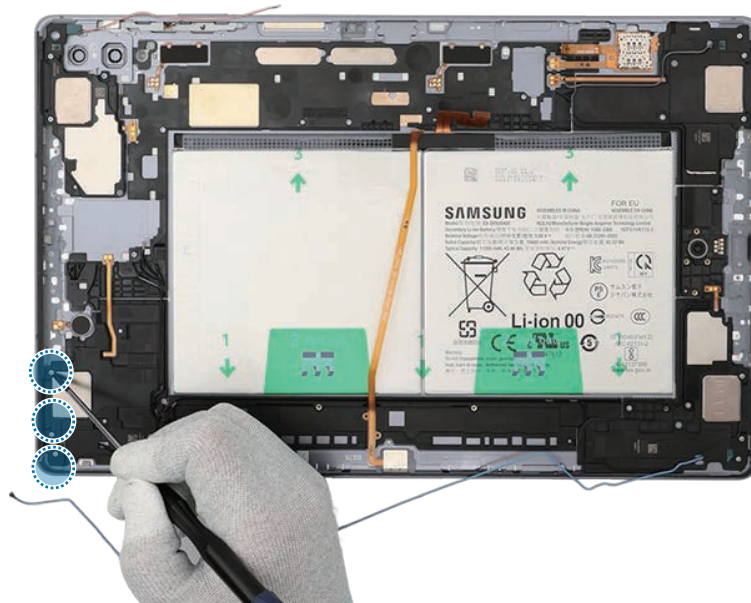

11 Heat the microwaveable heating bag and apply it to the both front and back side of the speaker1 module for 4 minutes.

- ⚠ • It is possible for the device or battery to be damaged by heat.
- Do not heat the device in a microwave. Doing so could cause an explosion.
- ⚠ • Follow the heating bag's instructions for heating. The recommended time for heating the bag is 50 seconds in a 1000 W microwave and 70 seconds in a 700 W microwave. (Correct temperature for use: 55-65 °C.)
- Be careful not to damage the device through excessive heat. (It is recommended to disassemble the device in an area with a temperature gauge.)
- 👉 When reheating, it should be heated no longer than 30 seconds.

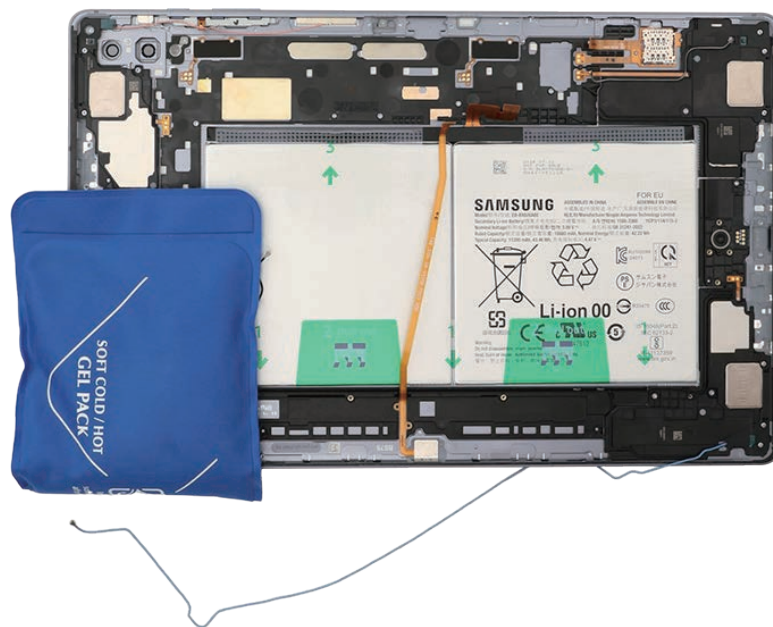

12 Using the tweezers, separate the FPCB of the speaker1 module carefully. Insert the tweezers into the separator groove of the speaker1 and remove it from the back cover module.

- ⚠ • Be careful not to damage the speaker and cable.
- Be careful not to damage the near components.

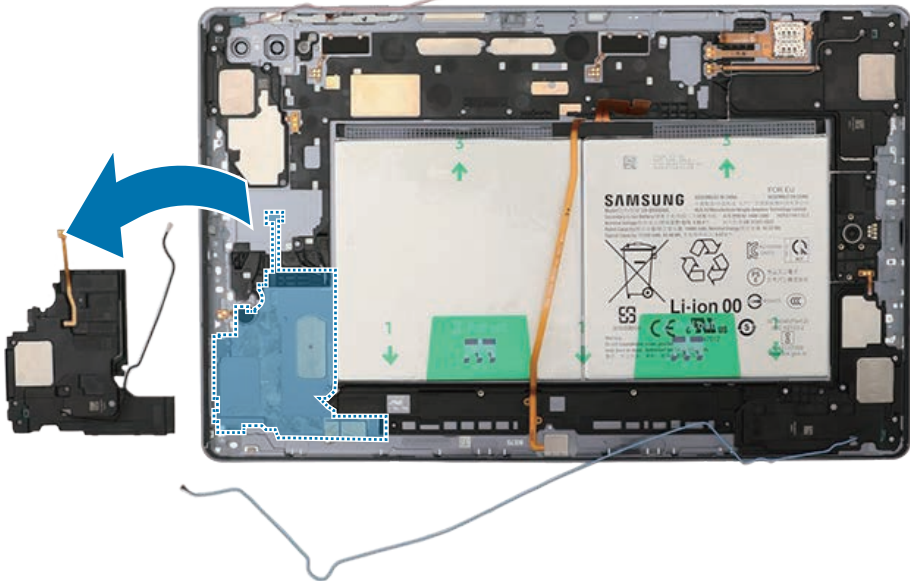
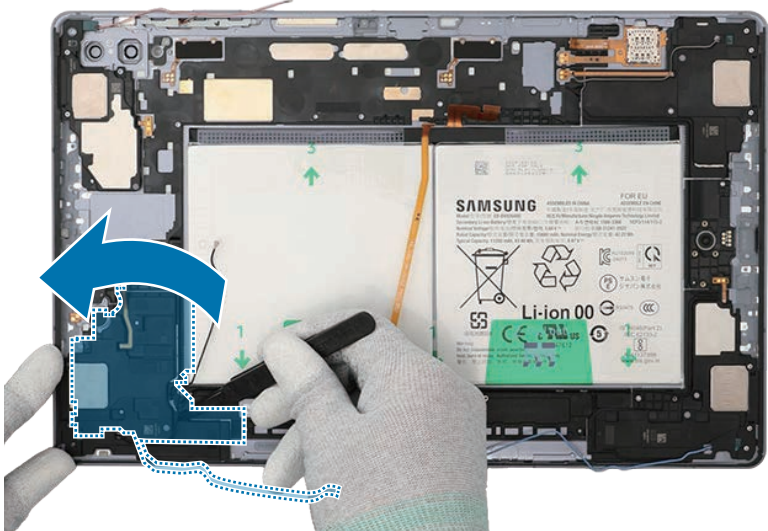
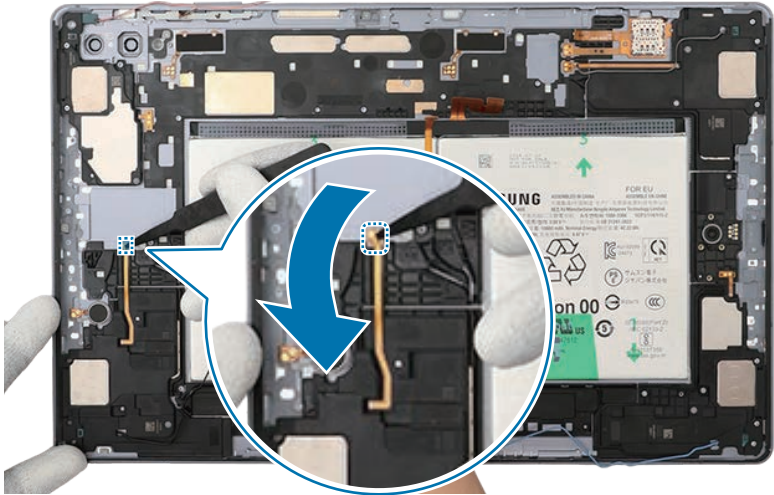

13 Check the screws at the 2 different points on the speaker 2 and remove them using a cross-head screwdriver.

⚠ Be careful not to damage the near components.

✓ Check the number of screws that have been removed, and store them carefully to make sure that no unassembled screws are left inside the device during assembly.

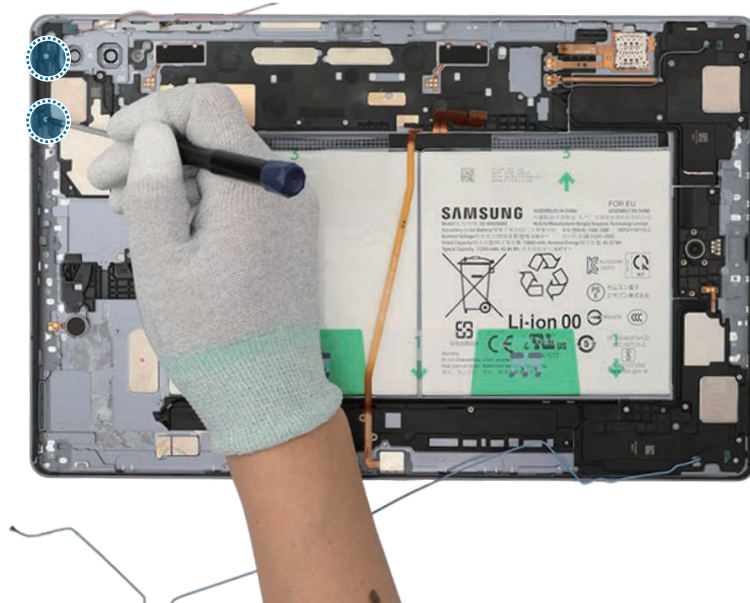

14 Heat the microwaveable heating bag and apply it to the both front and back side of the speaker 2 module for 4 minutes.

- ⚠ • It is possible for the device or battery to be damaged by heat.
- Do not heat the device in a microwave. Doing so could cause an explosion.
- ⚠ • Follow the heating bag's instructions for heating. The recommended time for heating the bag is 50 seconds in a 1000 W microwave and 70 seconds in a 700 W microwave. (Correct temperature for use: 55-65 °C.)
- Be careful not to damage the device through excessive heat. (It is recommended to disassemble the device in an area with a temperature gauge.)
- 📄 • When reheating, it should be heated no longer than 30 seconds.

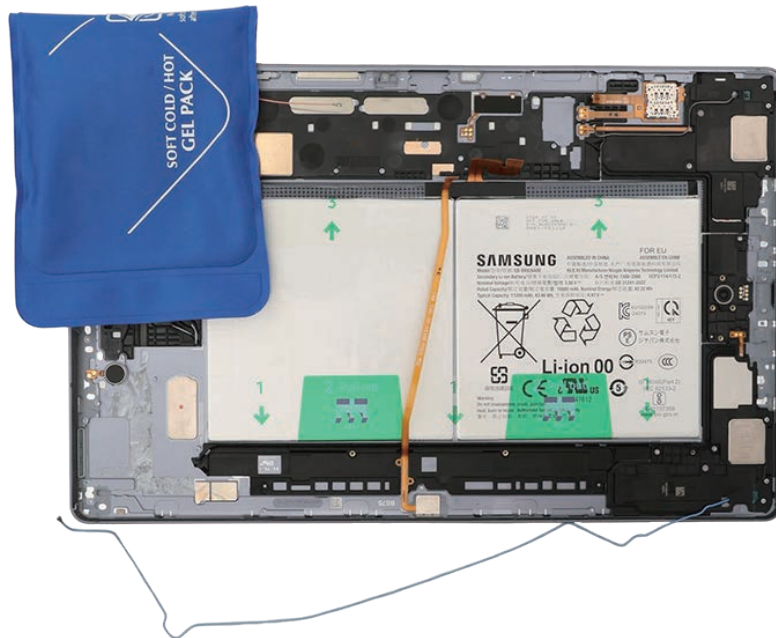

15 Using the tweezers, separate the FPCB of the speaker 2 module carefully. Insert the tweezers into the separator groove of the speaker 2 and remove it from the back cover module.

- ⚠ • Be careful not to damage the speaker and cable.
- Be careful not to damage the near components.

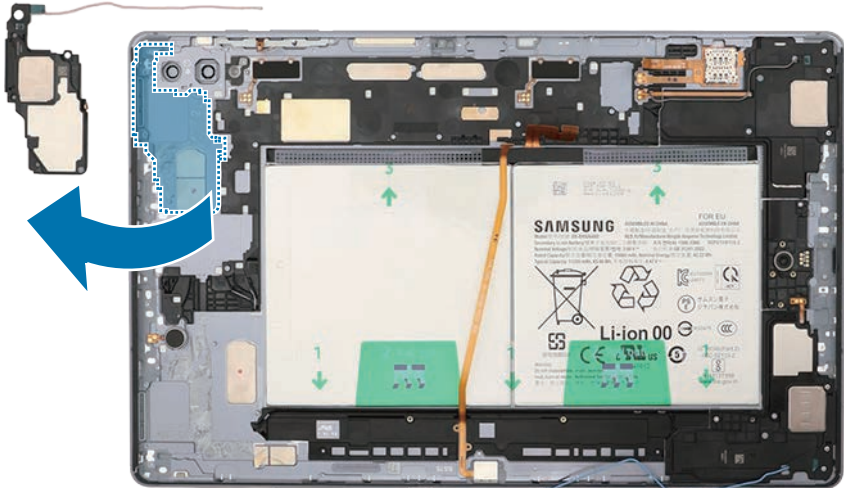
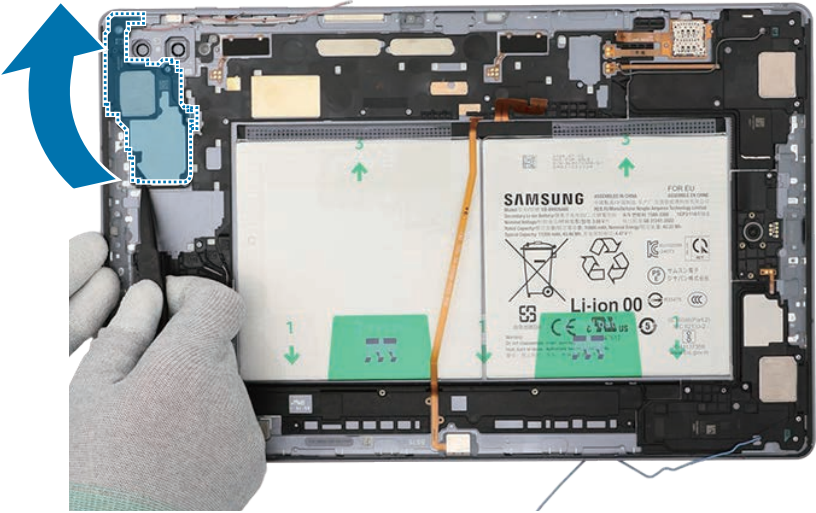
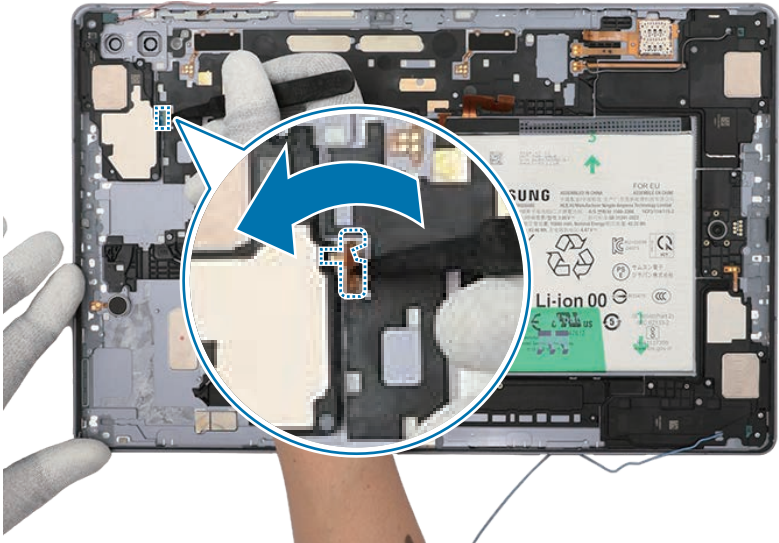

16 Check the screws at the 3 different points on the speaker 4 and remove them using a cross-head screwdriver.

⚠ Be careful not to damage the near components.

📝 Check the number of screws that have been removed, and store them carefully to make sure that no unassembled screws are left inside the device during assembly.

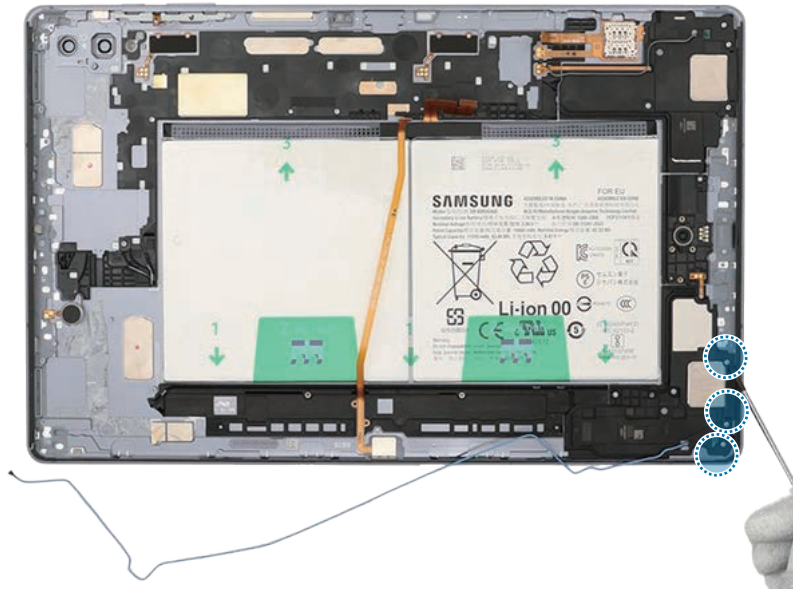

17 Heat the microwaveable heating bag and apply it to the both front and back side of the speaker 4 module for 4 minutes.

- ⚠ • It is possible for the device or battery to be damaged by heat.
- Do not heat the device in a microwave. Doing so could cause an explosion.
- ⚠ • Follow the heating bag's instructions for heating. The recommended time for heating the bag is 50 seconds in a 1000 W microwave and 70 seconds in a 700 W microwave. (Correct temperature for use: 55-65 °C.)
- Be careful not to damage the device through excessive heat. (It is recommended to disassemble the device in an area with a temperature gauge.)
- 👉 When reheating, it should be heated no longer than 30 seconds.

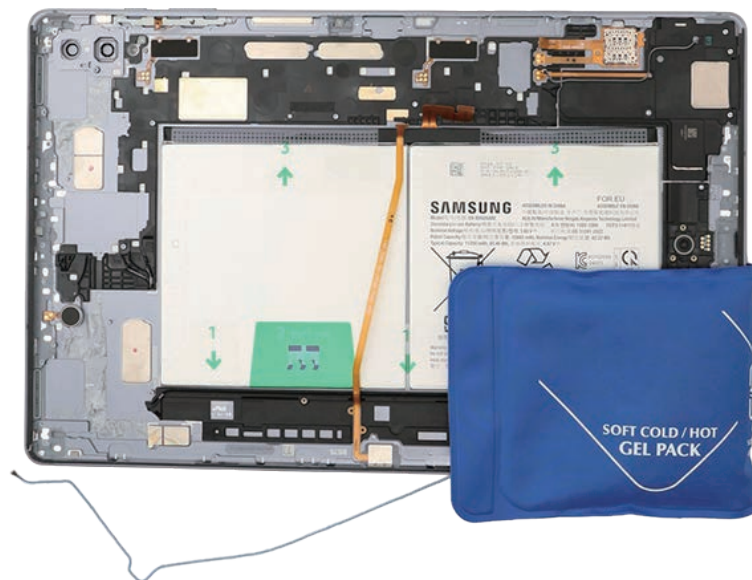

18 Using the tweezers, separate the FPCB of the speaker 4 module carefully. Insert the tweezers into the separator groove of the speaker 4 and remove it from the back cover module.

- ⚠ • Be careful not to damage the speaker and cable.
- Be careful not to damage the near components.

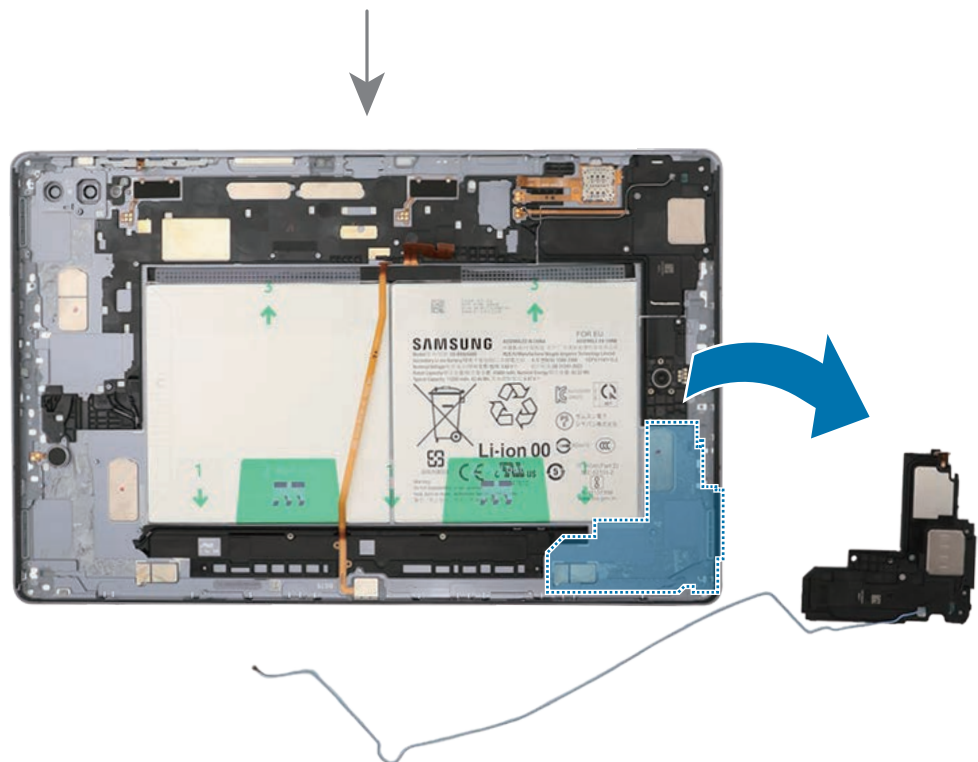
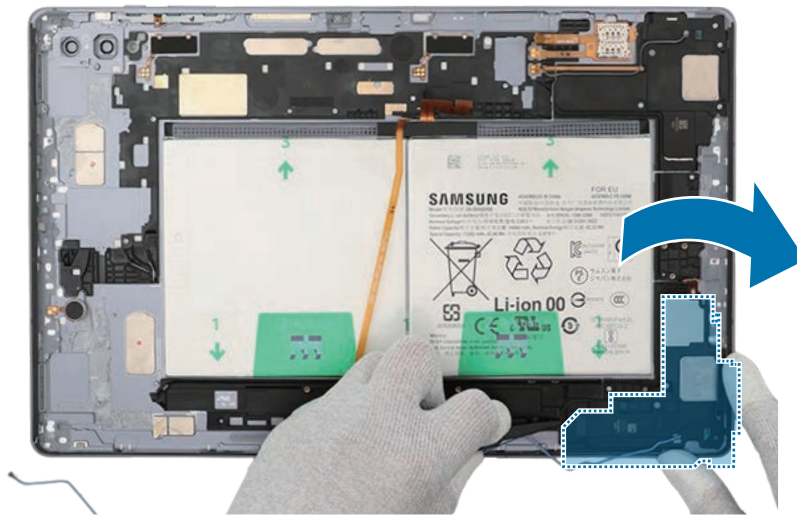
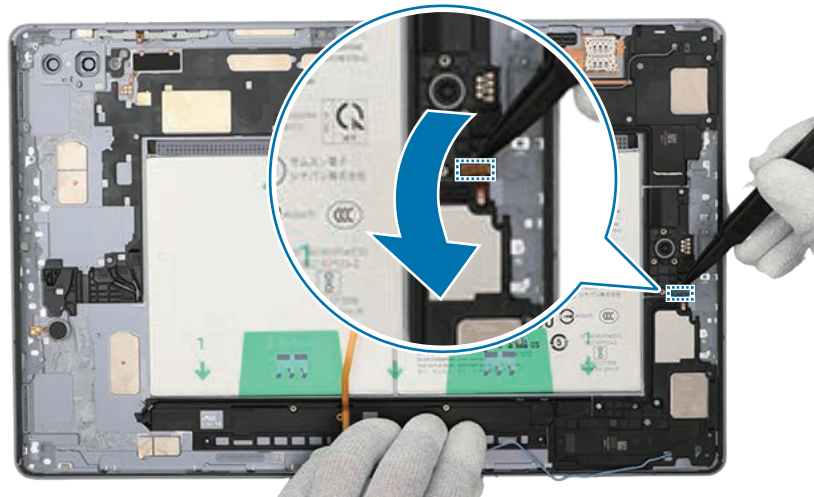

19 Check the screws at the 3 different points on the speaker 3 and remove them using a cross-head screwdriver.

⚠ Be careful not to damage the near components.

✓ Check the number of screws that have been removed, and store them carefully to make sure that no unassembled screws are left inside the device during assembly.

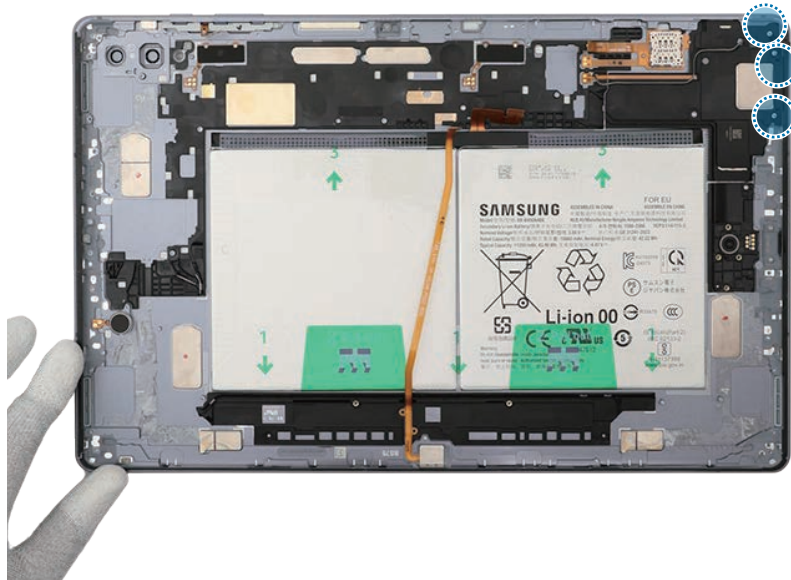

20 Heat the microwaveable heating bag and apply it to the both front and back side of the speaker 3 module for 4 minutes.

- ⚠ • It is possible for the device or battery to be damaged by heat.
- Do not heat the device in a microwave. Doing so could cause an explosion.
- ⚠ • Follow the heating bag's instructions for heating. The recommended time for heating the bag is 50 seconds in a 1000 W microwave and 70 seconds in a 700 W microwave. (Correct temperature for use: 55-65 °C.)
- Be careful not to damage the device through excessive heat. (It is recommended to disassemble the device in an area with a temperature gauge.)
- 📄 • When reheating, it should be heated no longer than 30 seconds.

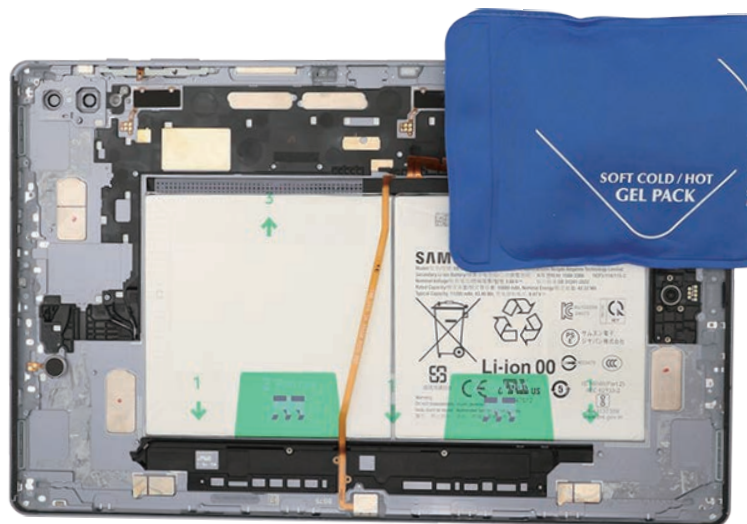

21 Using the tweezers, separate the FPCB of the speaker 3 module carefully. Insert the tweezers into the separator groove of the speaker 3 and remove it from the back cover module.

- ⚠ • Be careful not to damage the speaker and cable.
- Be careful not to damage the near components.

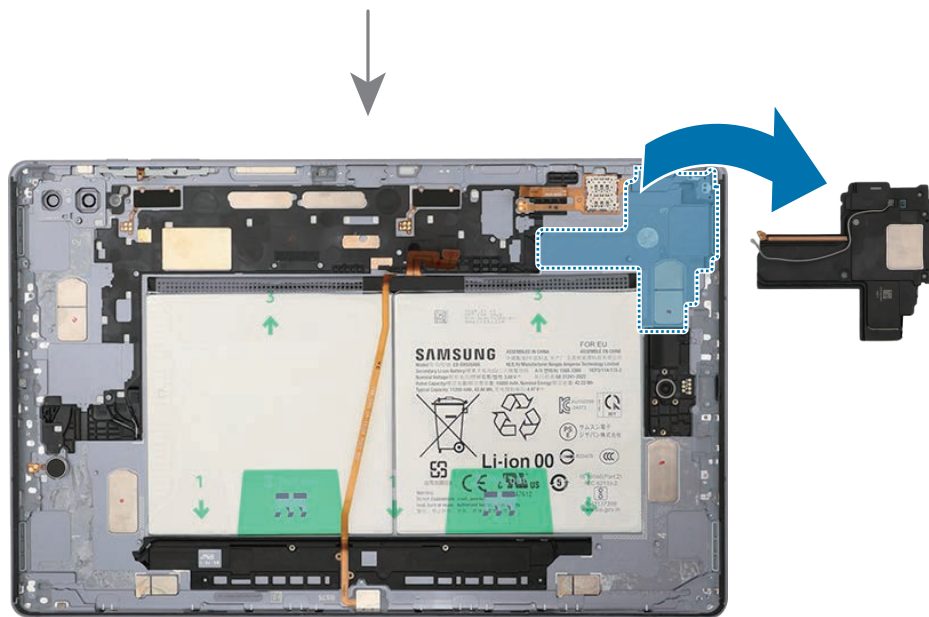
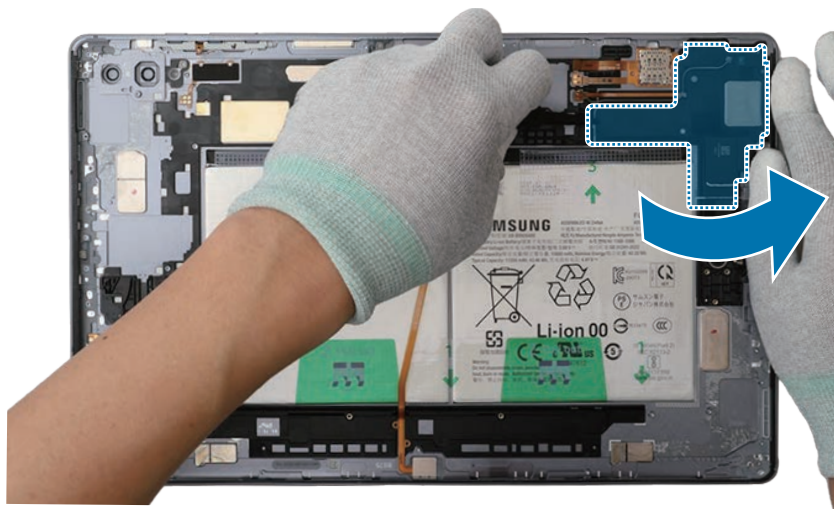
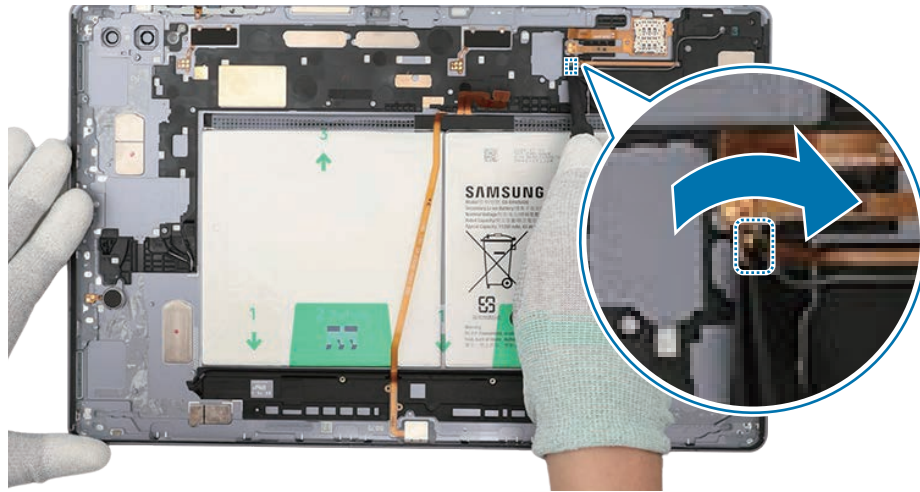

22 Using the tweezers, separate the FPCB of the vibrator motor carefully from the back cover module. Then, lift up on the separator groove of the vibrator motor and remove it carefully from the back cover module.

⚠ Be careful not to damage the vibrator motor and the FPCB.

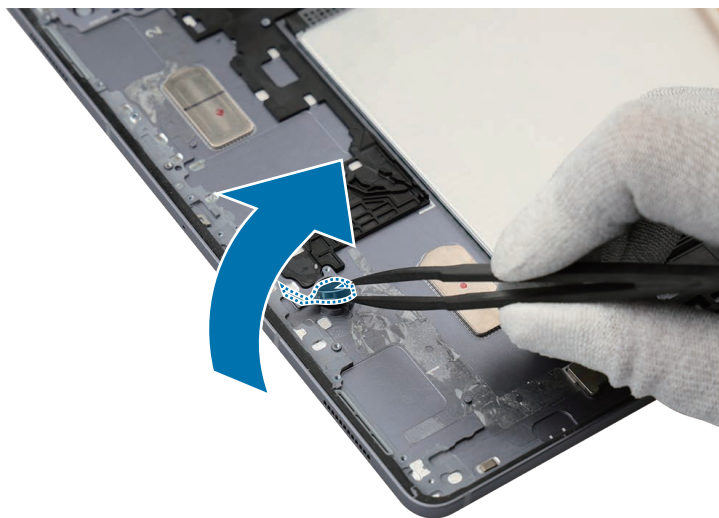
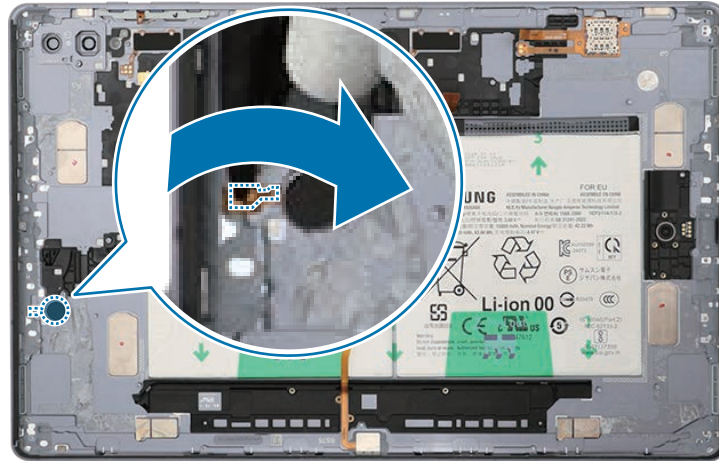

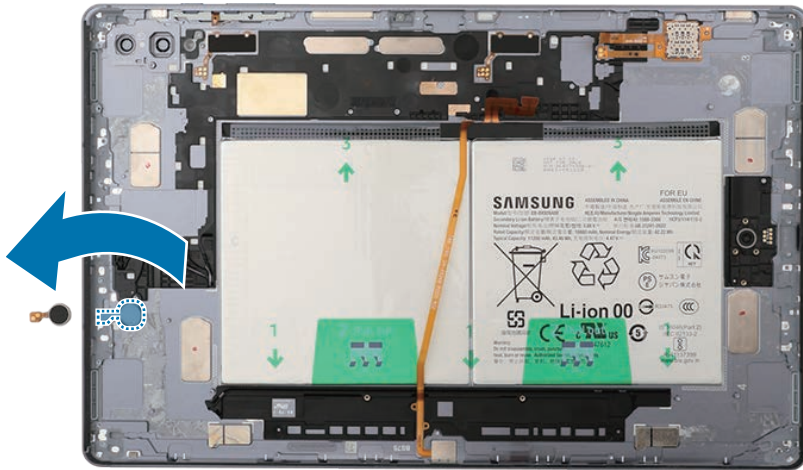

23 Using the tweezers, separate the FPCB of the SIM card socket carefully from the back cover module. Then, lift up on the separator groove of the SIM card socket and remove it carefully from the back cover module.

⚠ Be careful not to damage the SIM card socket and the FPCB.

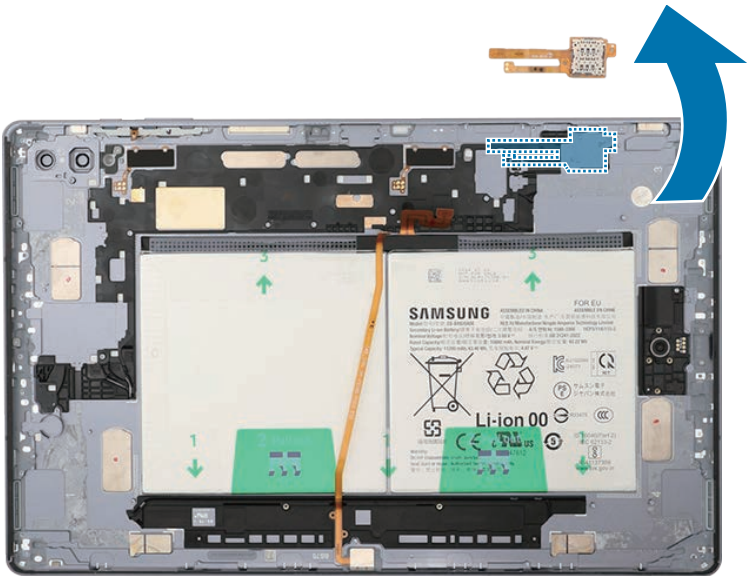
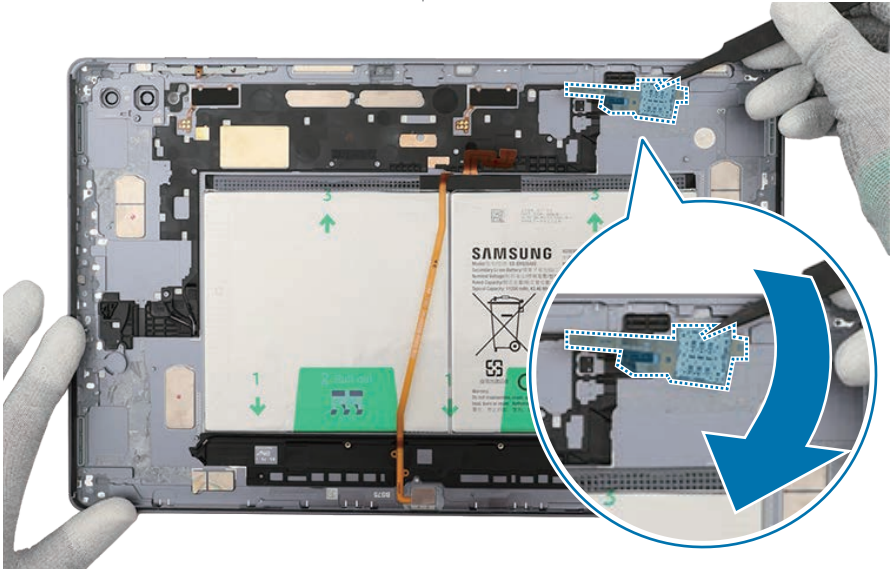
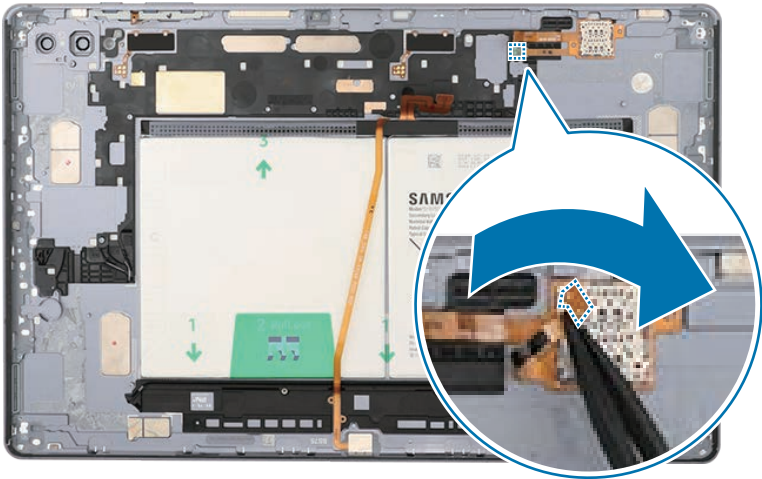

Reassembly

! Leaving screws inside the device may damage internal components, such as the battery. During assembly, be extra careful not to leave any unassembled screws inside the device.

1 If you use the existing SIM card socket as it is when reassembling, remove all adhesive tapes on the bottom of the SIM card socket using the tweezers.

! Be careful not to damage the SIM card socket.

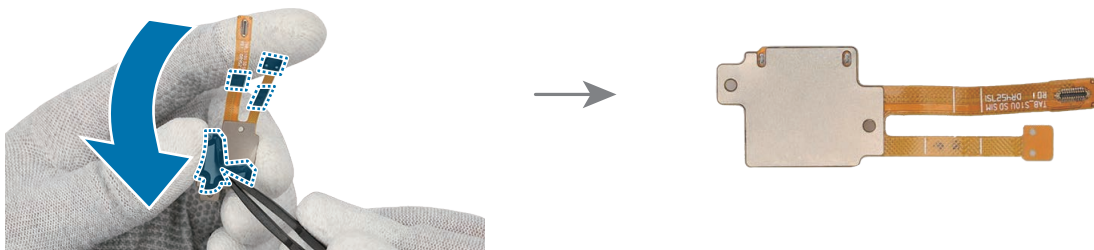

2 Using the tweezers, remove the clear film from the new SIM card socket FPCB adhesive tape and apply it to the bottom of the SIM card socket's FPCB. Gently press down on the tape with your fingers so that it can be attached well.

! Be careful not to damage the SIM card socket.

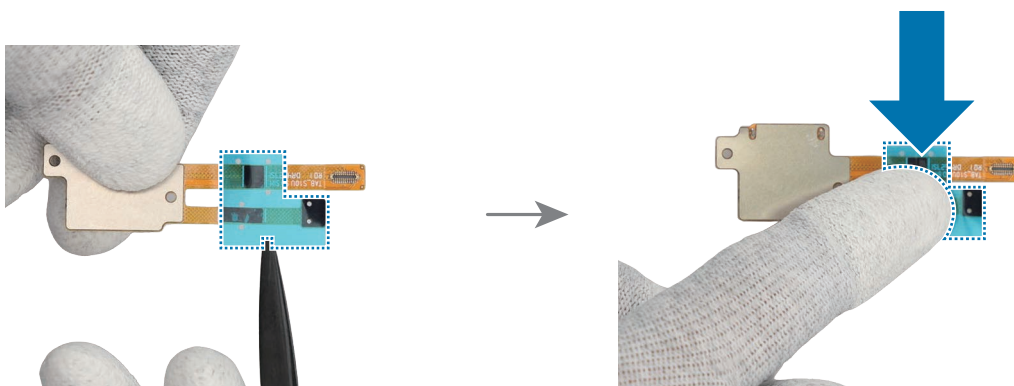

- 3 Using the tweezers, remove the clear film from the new SIM card socket adhesive tape and apply it to the bottom of the SIM card socket. Gently press down on the tape with your fingers so that it can be attached well.

⚠ Be careful not to damage the SIM card socket.

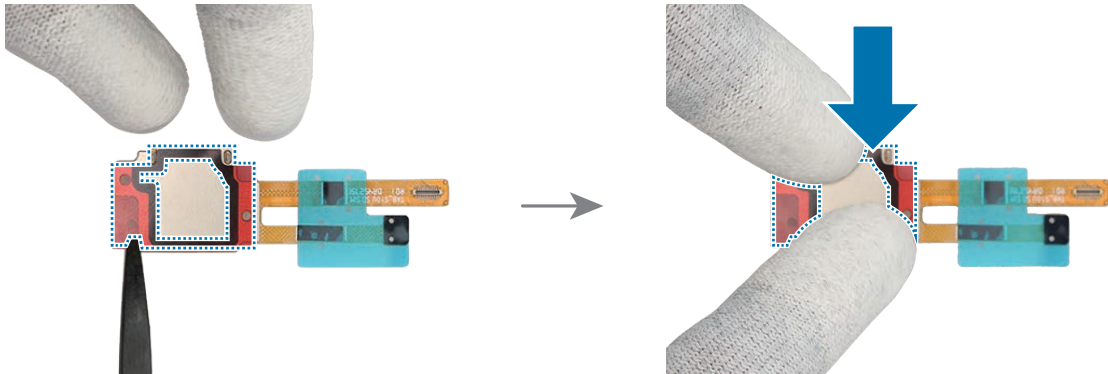

- 4 Using the tweezers, hold the protruding release films of all the attached tapes and carefully remove them.

⚠ Be careful not to damage the SIM card socket.

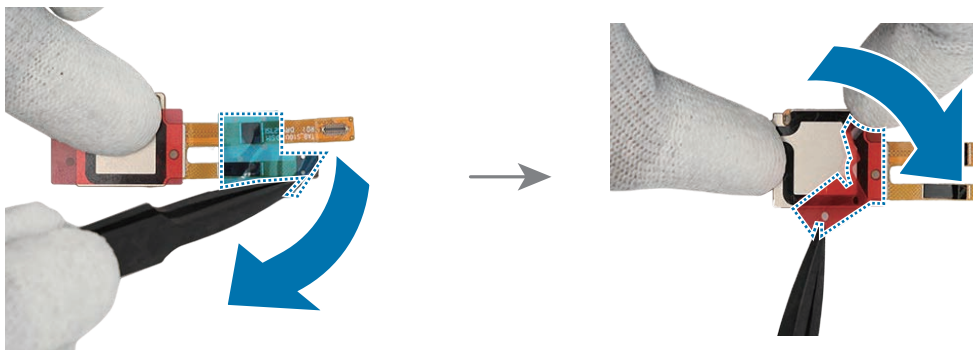

- 5 Using the tweezers, assemble the SIM card socket to the exact position of the back cover module and press it down lightly with your fingers so that it is fully attached.

⚠ Be careful not to damage the SIM card socket and near components.

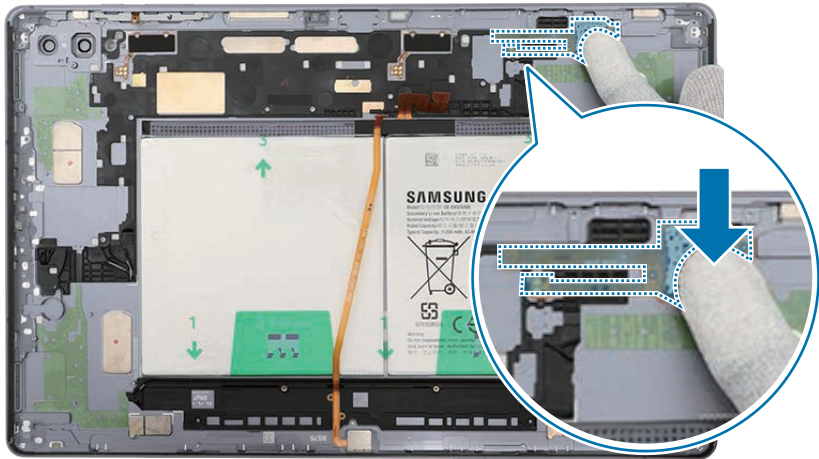
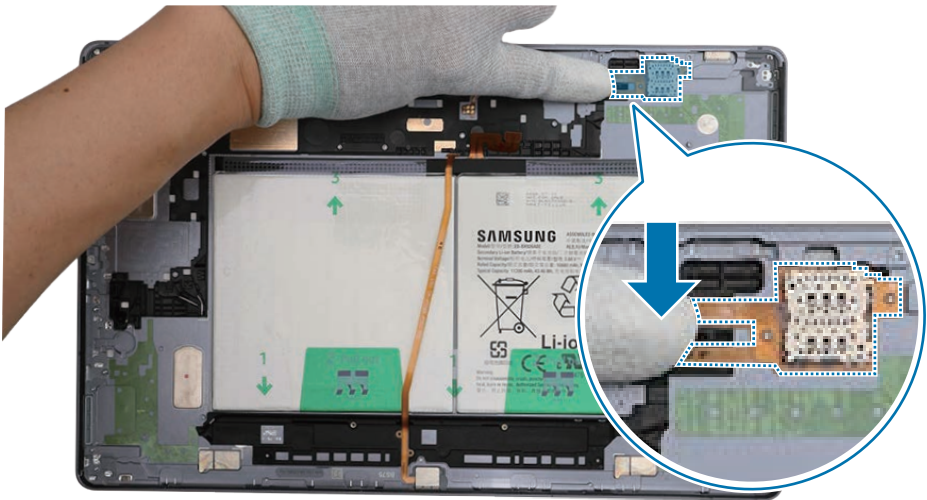
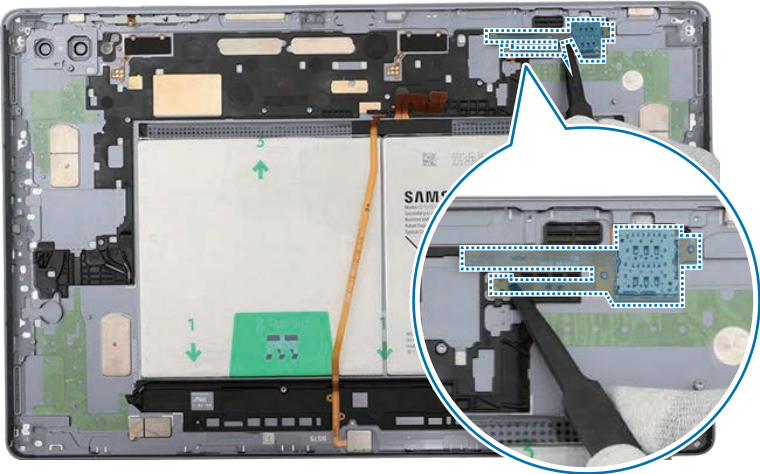

6 If you use the existing vibrator motor as it is, remove all adhesive tapes on the bottom of the vibrator motor using the tweezers.

⚠ Be careful not to damage the vibrator motor and the FPCB.

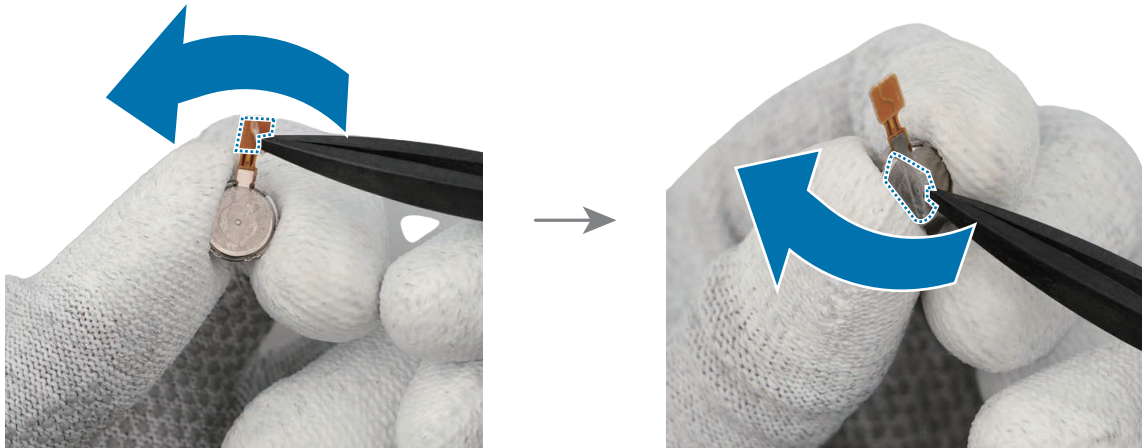

7 Using the tweezers, remove the clear film from the new vibrator motor FPCB adhesive tape and apply it to the bottom of the vibrator motor's FPCB. Gently press down on the tape with your fingers so that it can be attached well.

⚠ Be careful not to damage the vibrator motor and the FPCB.

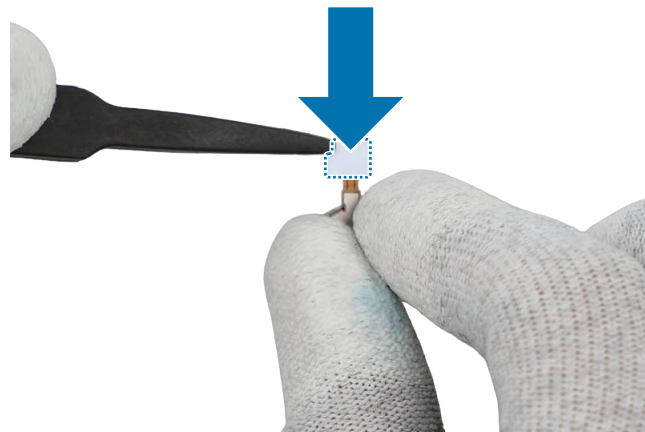

- 8 Using the tweezers, remove the clear film from the new vibrator motor adhesive tape and apply it to the bottom of the vibrator motor. Gently press down on the tape with your fingers so that it can be attached well.

⚠ Be careful not to damage the vibrator motor and the FPCB.

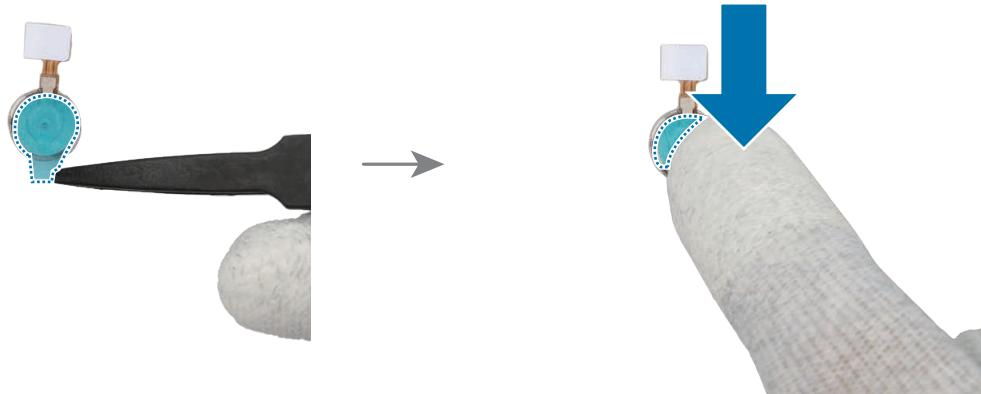

- 9 Using the tweezers, hold the protruding release films of all the attached tapes and carefully remove them.

⚠ Be careful not to damage the vibrator motor and the FPCB.

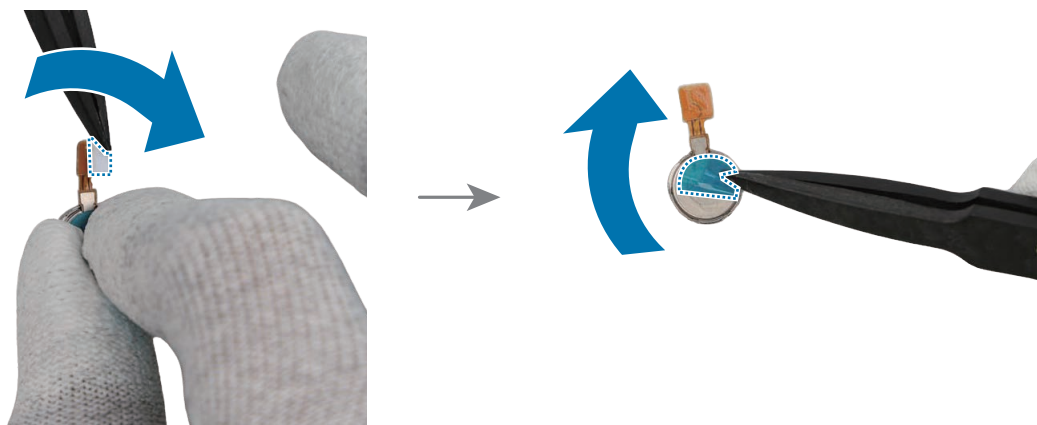

- 10 Using the tweezers, assemble the vibrator motor to the exact position of the back cover module and press it down lightly with your fingers so that it is fully attached.

⚠ Be careful not to damage the vibrator motor and near components.

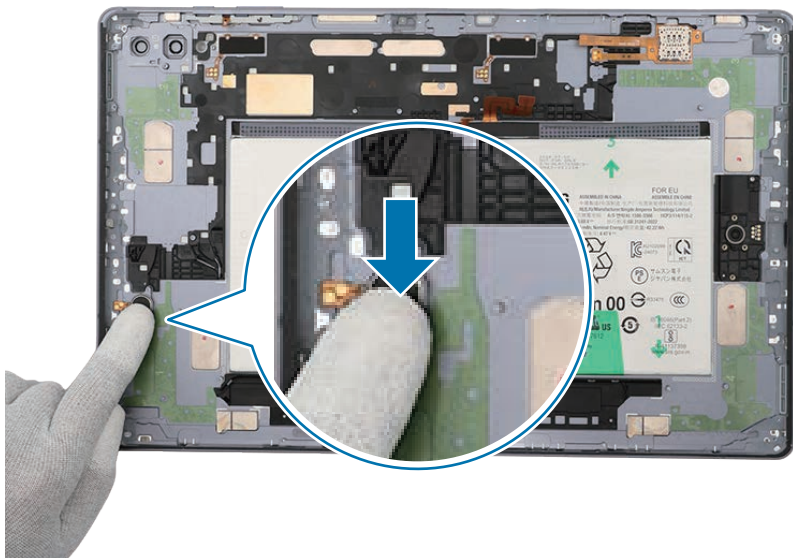
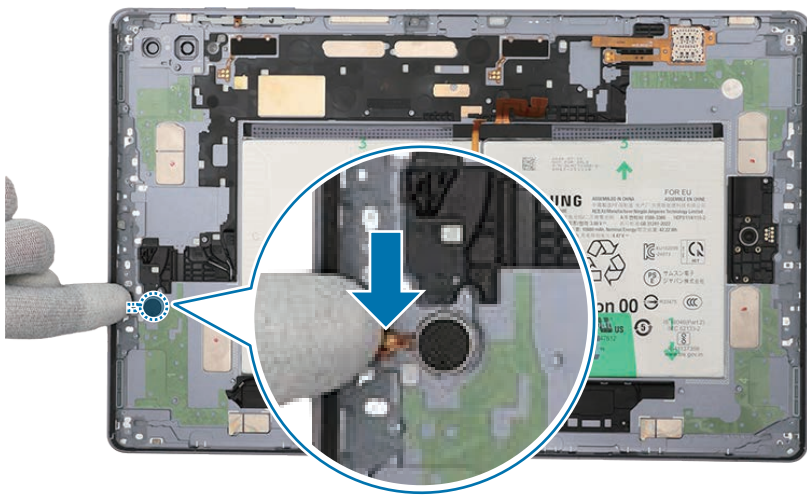
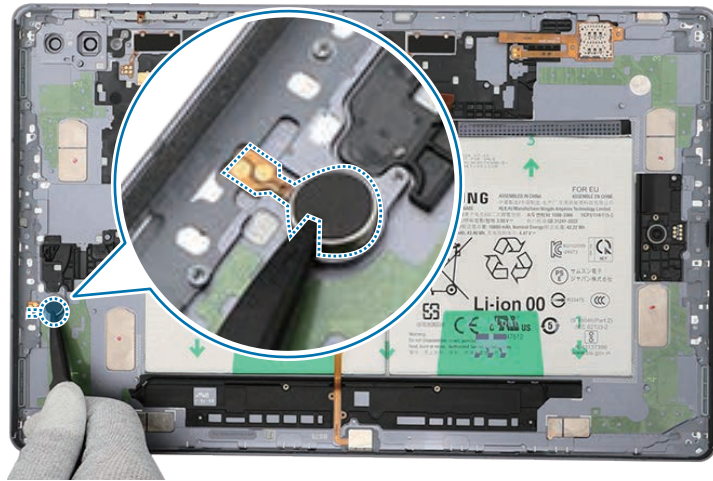

11 If you use the existing speaker 3 as it is, remove all adhesive tapes on the bottom of the speaker 3 module's FPCB using the tweezers.

⚠ Be careful not to damage the speaker and the FPCB.

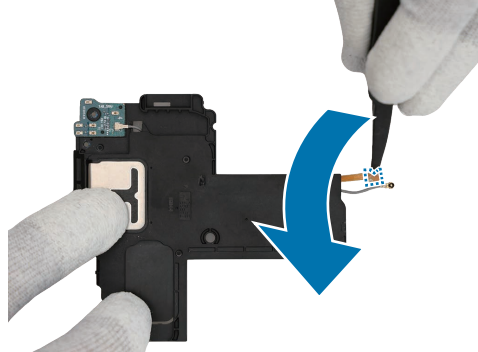

12 Remove the release film from the new FPCB tape and attach it to the FPCB of the speaker 3 module with the tweezers. Gently press down on the tape with your fingers so that it can be attached well.

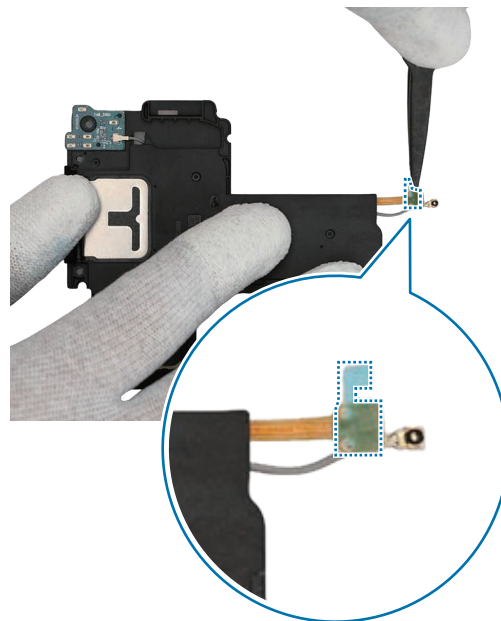

- Using the tweezers, remove the release film of the tape attached on the speaker 3 position of the back cover module.

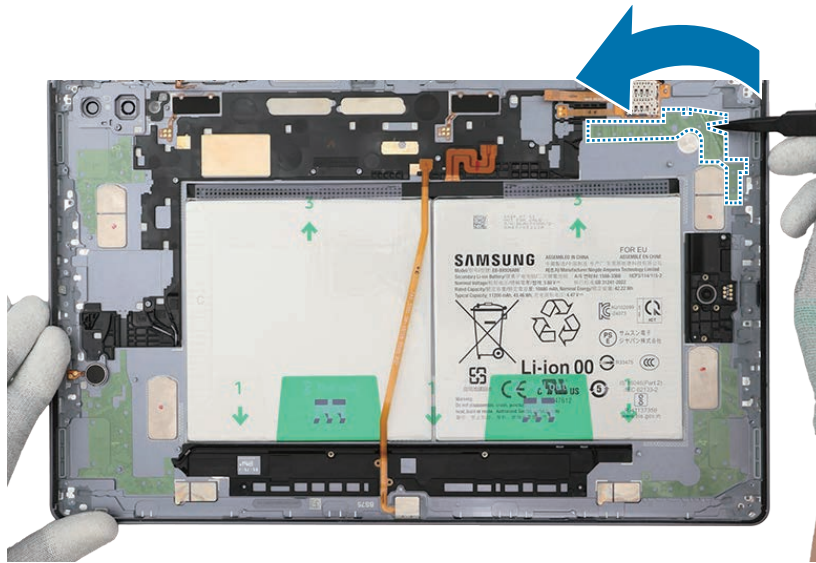

14 Using the tweezers, remove the release film from the speaker 3 module. Place the speaker 3 module to the exact position and assemble it to the back cover module.

- ⚠ Be careful not to damage the battery.
- ⚠ • Be careful not to damage the speaker and cable.
- Be careful not to damage the near components.

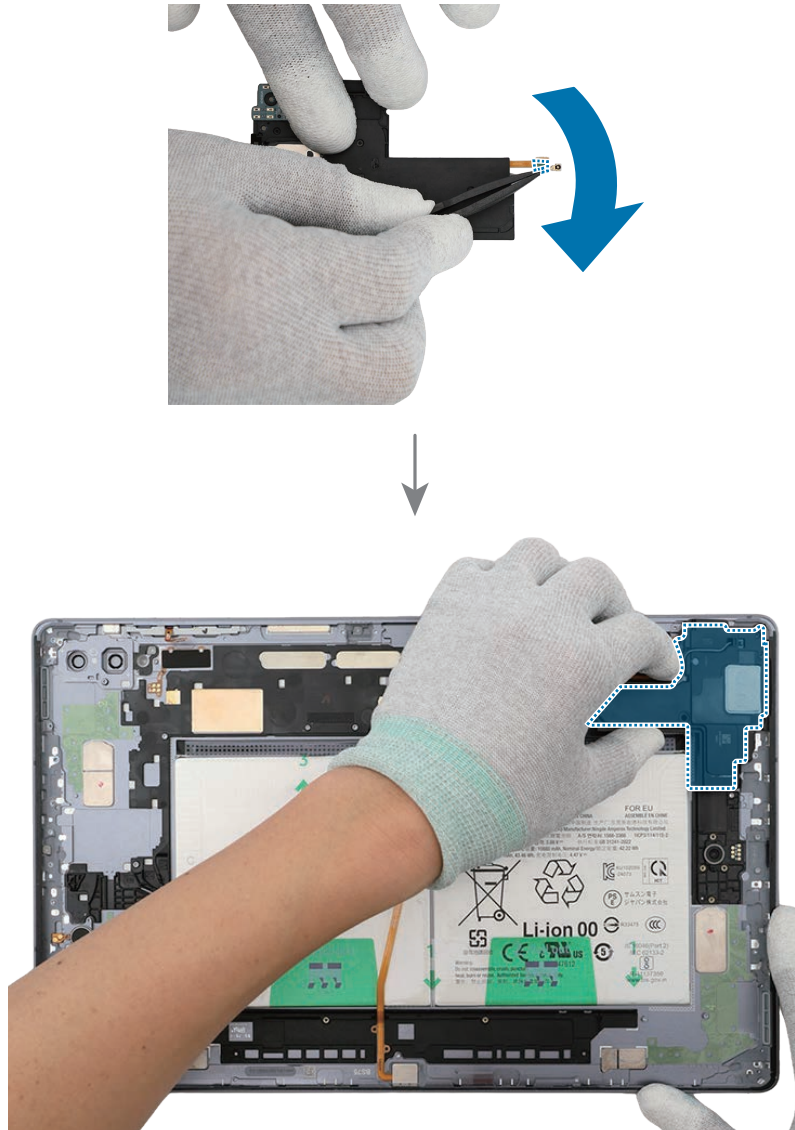

15 Using your fingers, press down softly and evenly on the speaker 3 module and the FPCB so that the speaker 3 module can be completely attached.

⚠ Be careful not to damage the speaker and cable.

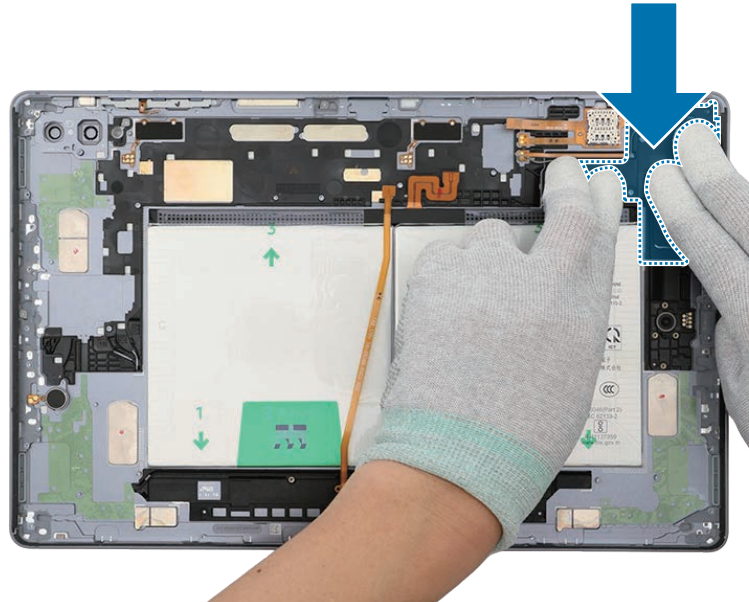

16 Check the screw 3405 (3 ea) and fasten them on the speaker 3 using a cross-head screwdriver.

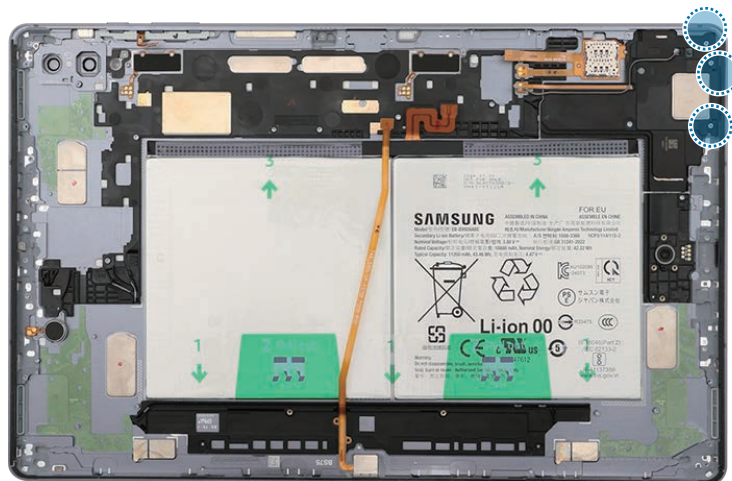

17 If you use the existing speaker 4 as it is, remove all adhesive tapes on the bottom of the speaker 4 module's FPCB using the tweezers.

⚠ Be careful not to damage the speaker and the FPCB.

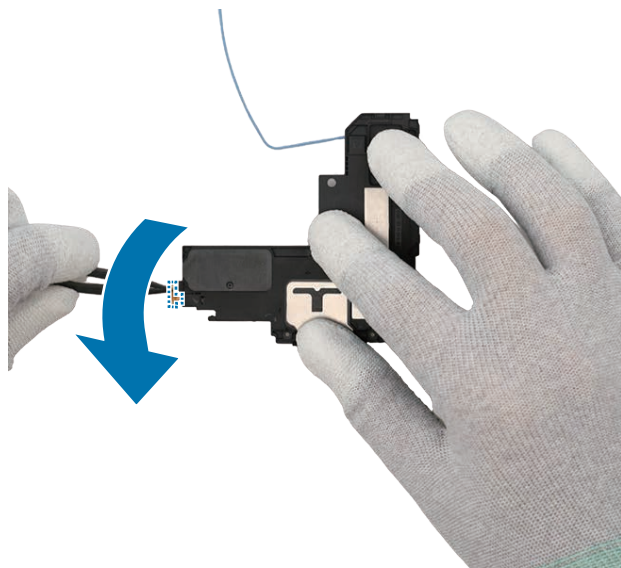

18 Remove the release film from the new FPCB tape and attach it to the FPCB of the speaker 4 module with the tweezers. Gently press down on the tape with your fingers so that it can be attached well.

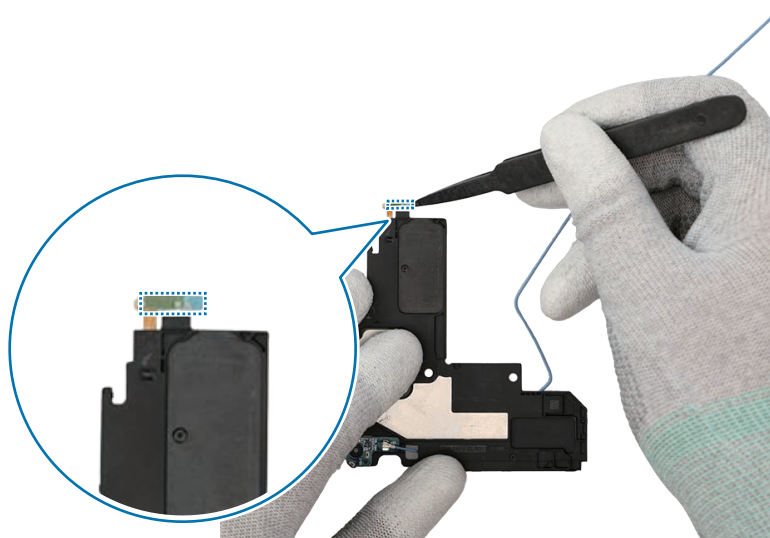

- 19 Using the tweezers, remove the release film of the tape attached on the speaker 4 position of the back cover module.

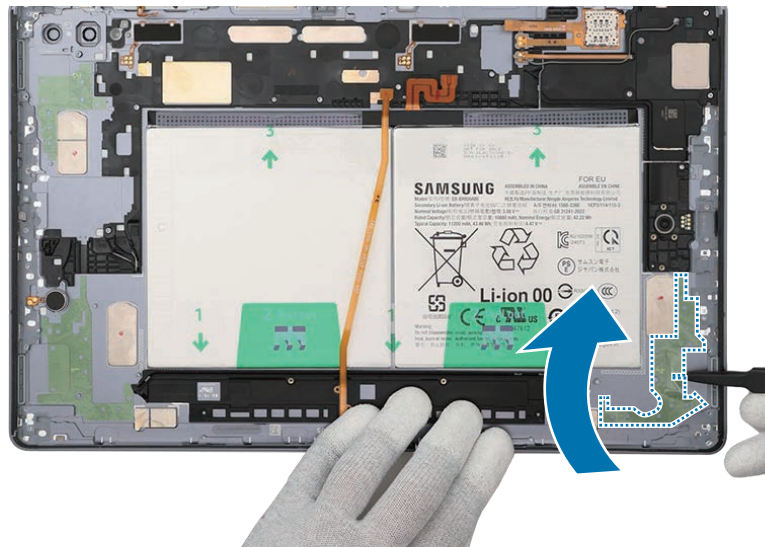

20 Using the tweezers, remove the release film from the speaker 4 module. Place the speaker 4 module to the exact position and assemble it to the back cover module.

- ⚠ Be careful not to damage the battery.
- ⚠ • Be careful not to damage the speaker and cable.
- Be careful not to damage the near components.

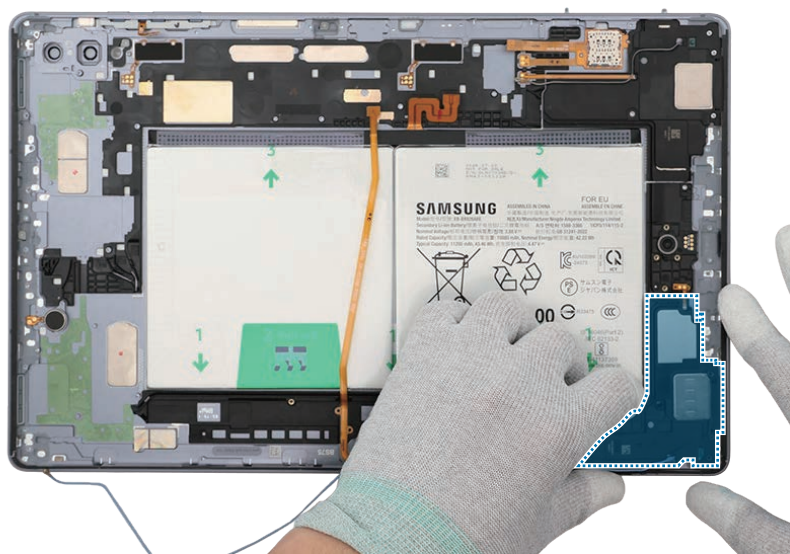
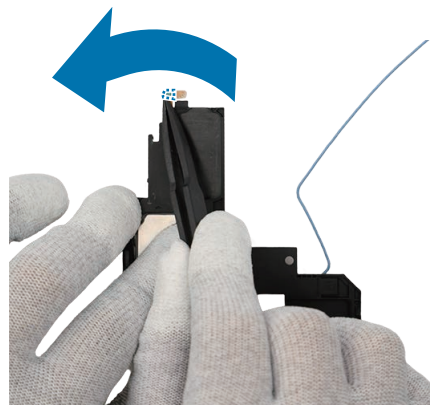

21 Using your fingers, press down softly and evenly on the speaker 4 module and the FPCB so that the speaker 4 module can be completely attached.

⚠ Be careful not to damage the speaker and cable.

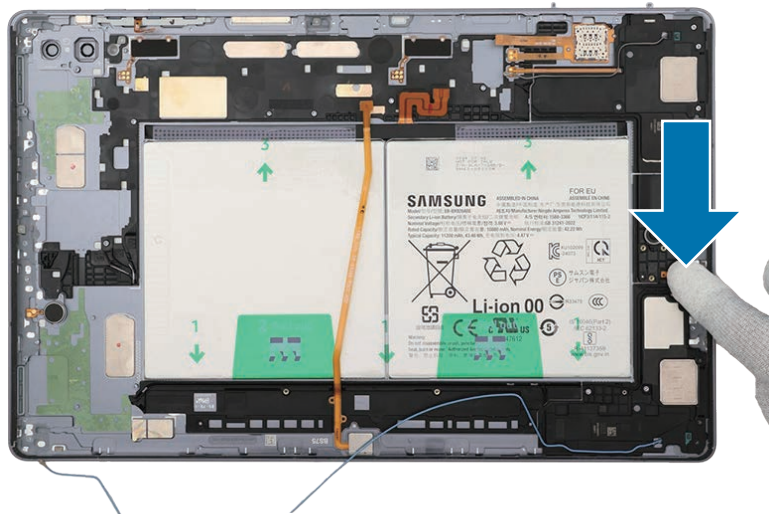
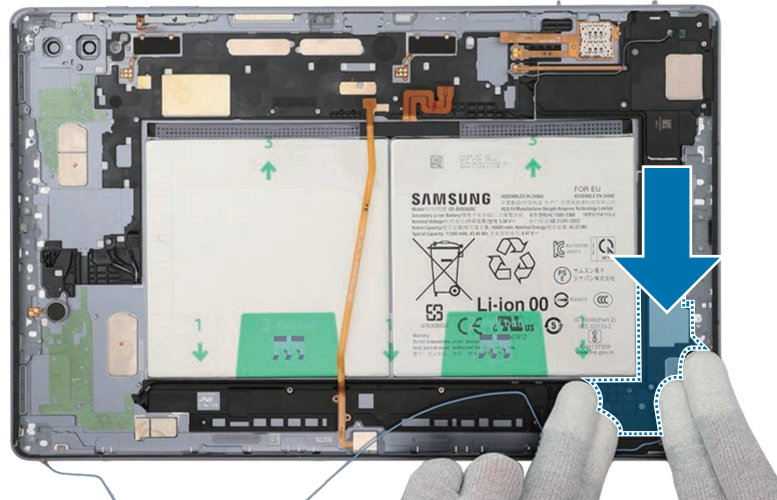

- 22 Check the screw 3405 (3 ea) and fasten them on the speaker 4 using a cross-head screwdriver.

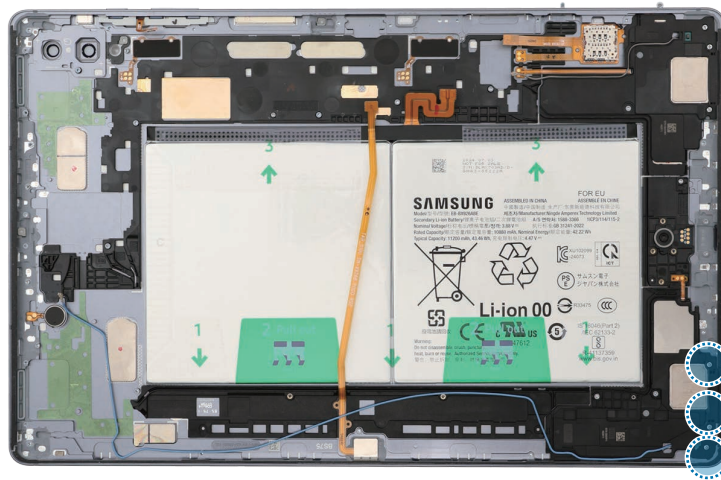

- 23 If you use the existing speaker 2 as it is, remove all adhesive tapes on the bottom of the speaker 2 module's FPCB using the tweezers.

- ⚠ Be careful not to damage the speaker and the FPCB.

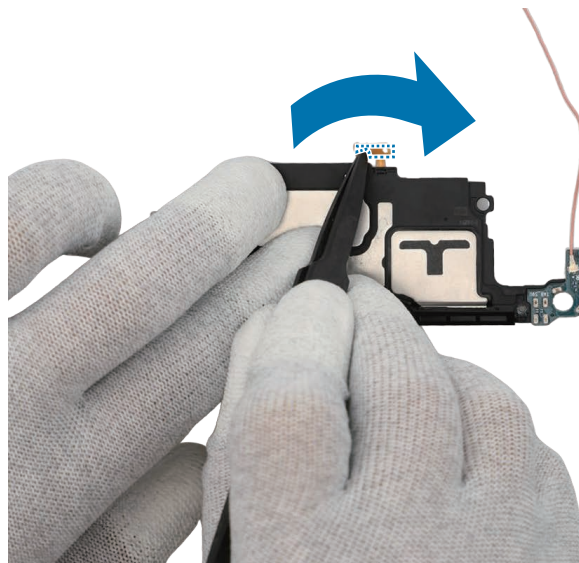

- 24 Remove the release film from the new FPCB tape and attach it to the FPCB of the speaker 2 module with the tweezers. Gently press down on the tape with your fingers so that it can be attached well.

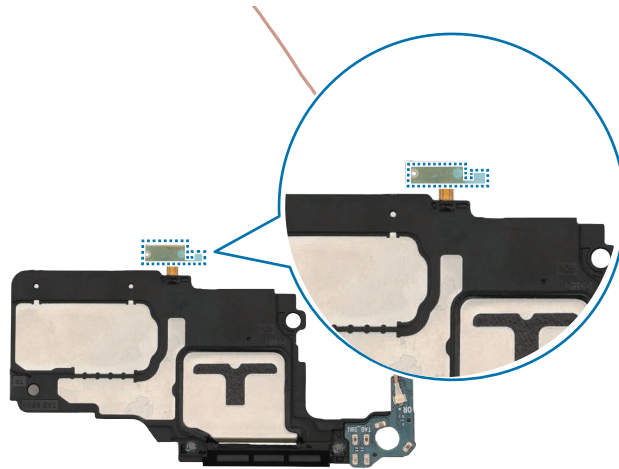

- 25 Using the tweezers, remove the release film of the tape attached on the speaker 2 position of the back cover module.

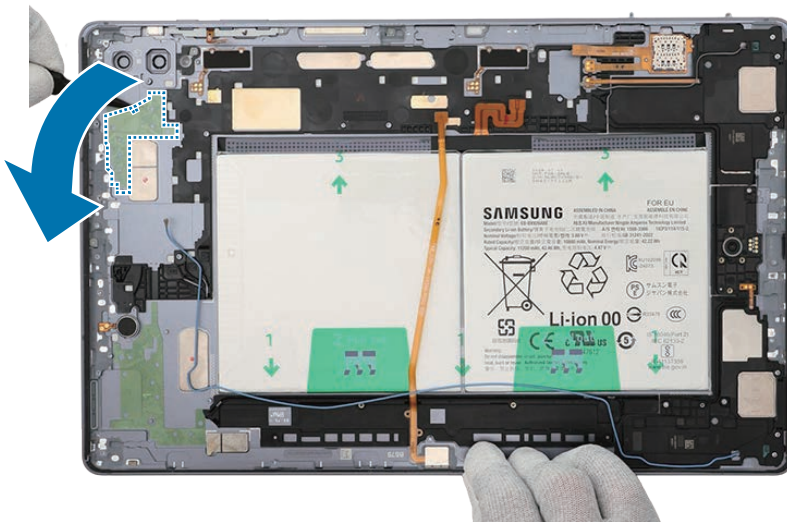

- 26 For models without the speaker 2 adhesive tape on the new back cover module, attach the enclosed speaker 2 adhesive tape to the bottom of the speaker 2. Gently press down on the tape with your fingers so that it can be attached well, and remove the release film from the tape.

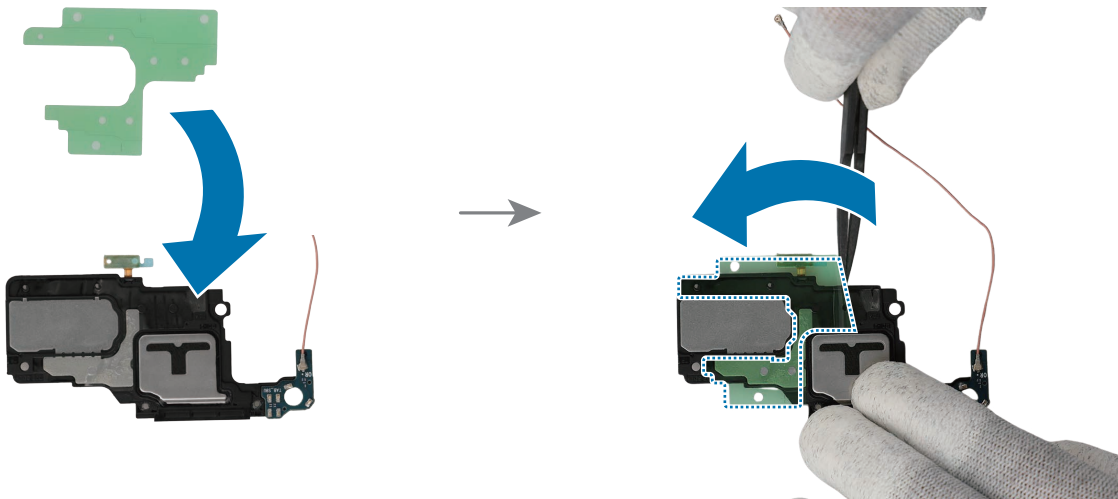
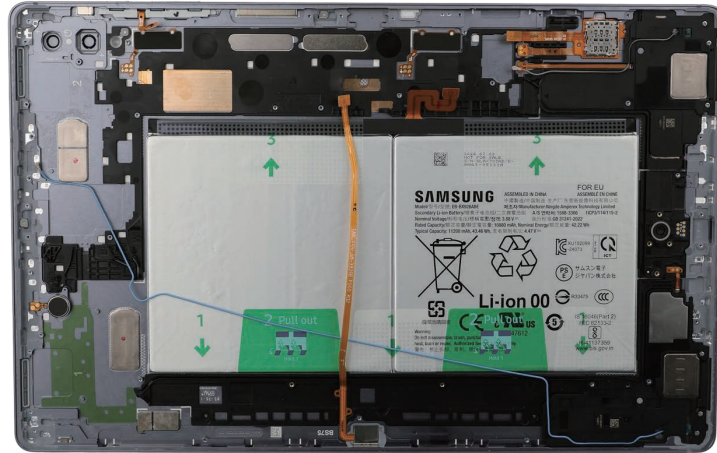

27 Using the tweezers, remove the release film from the speaker 2 module. Place the speaker 2 module to the exact position and assemble it to the back cover module.

⚠ Be careful not to damage the battery.

- ⚠ • Be careful not to damage the speaker and cable.
- Be careful not to damage the near components.

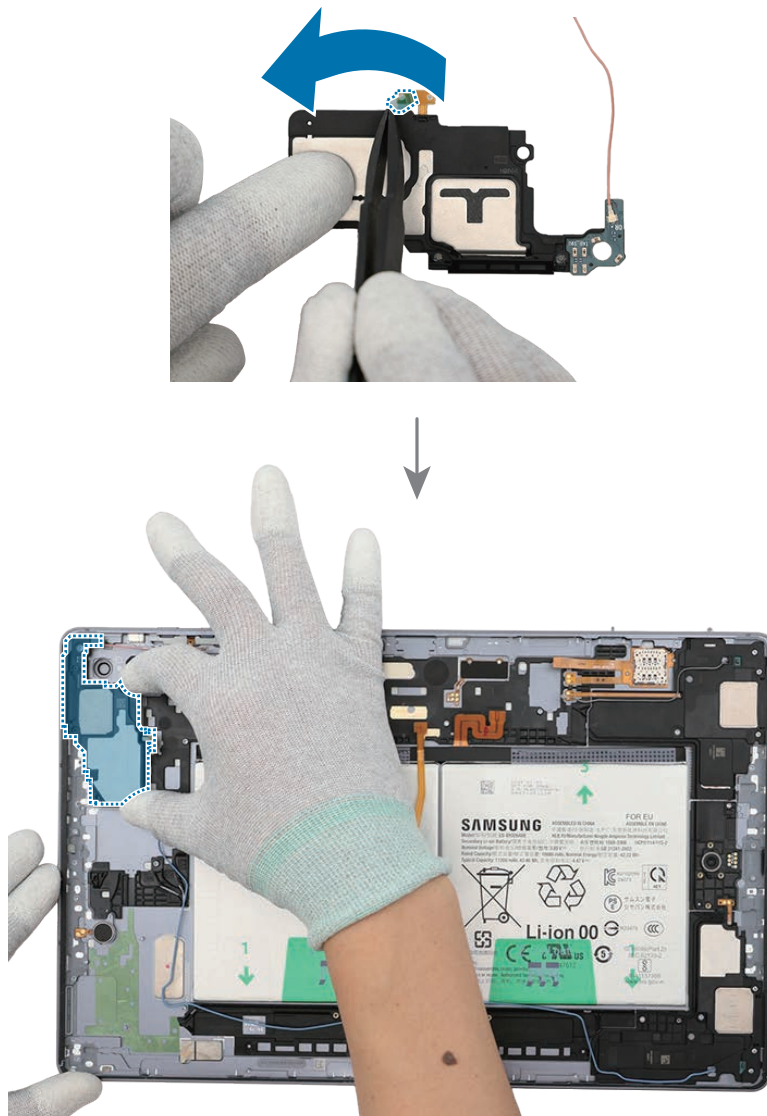

28 Using your fingers, press down softly and evenly on the speaker 2 module and the FPCB so that the speaker 2 module can be completely attached.

⚠ Be careful not to damage the speaker and cable.

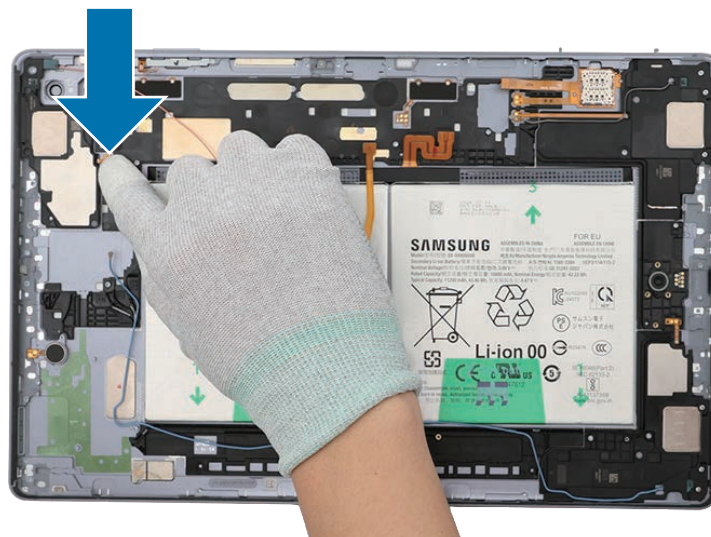
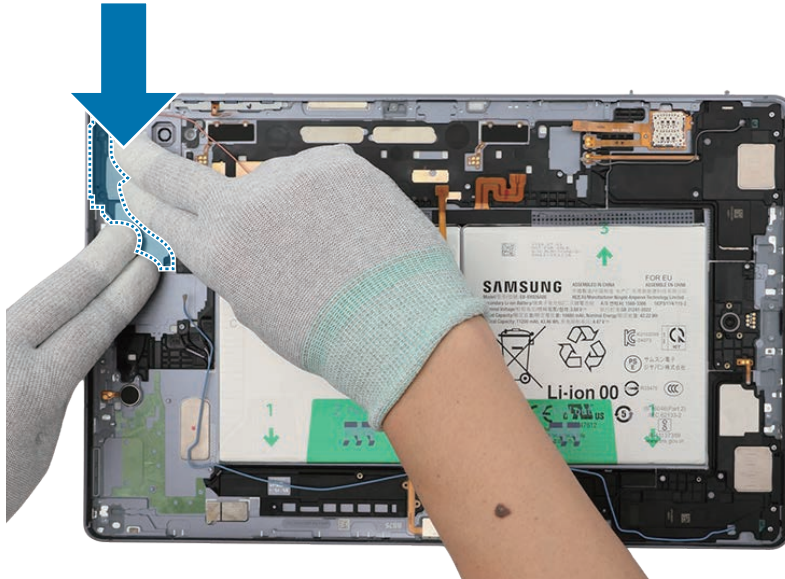

- 29 Check the screw 3405 (2 ea) and fasten them on the speaker 2 using a cross-head screwdriver.

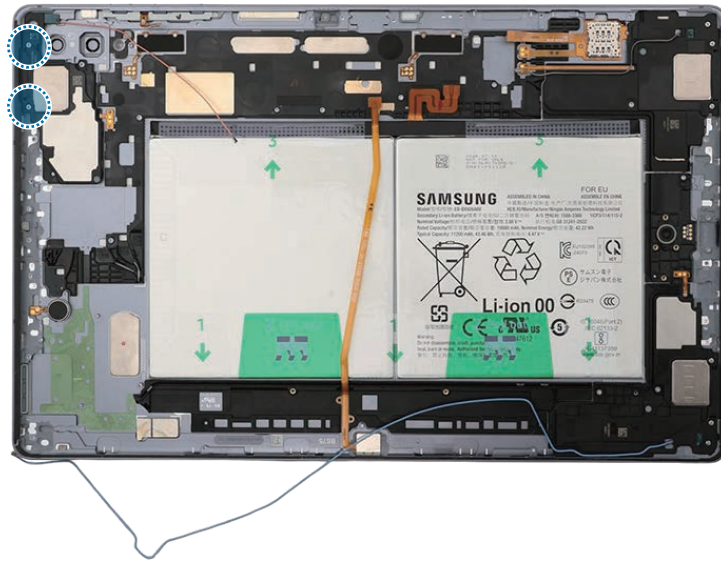

- 30 If you use the existing speaker1 as it is, remove all adhesive tapes on the bottom of the speaker1 module's FPCB using the tweezers.

⚠ Be careful not to damage the speaker and the FPCB.



- 31 Remove the release film from the new FPCB tape and attach it to the FPCB of the speaker1 module with the tweezers. Gently press down on the tape with your fingers so that it can be attached well.

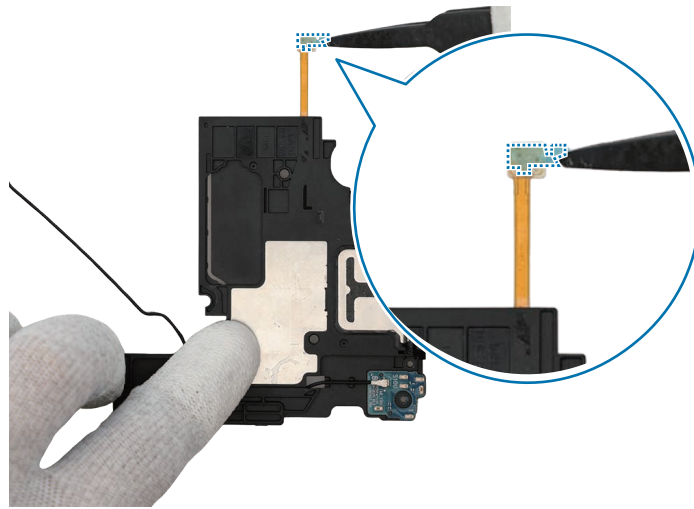

- 32 Using the tweezers, remove the release film of the tape attached on the speaker1 position of the back cover module.

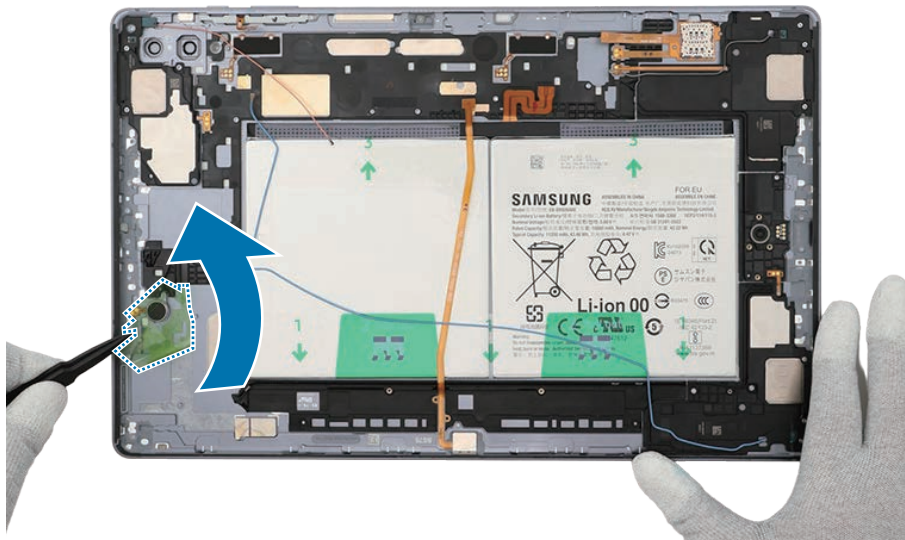

33 Using the tweezers, remove the release film from the speaker1 module. Place the speaker1 module to the exact position and assemble it to the back cover module.

- ⚠ Be careful not to damage the battery.
- ⚠ • Be careful not to damage the speaker and cable.
- Be careful not to damage the near components.

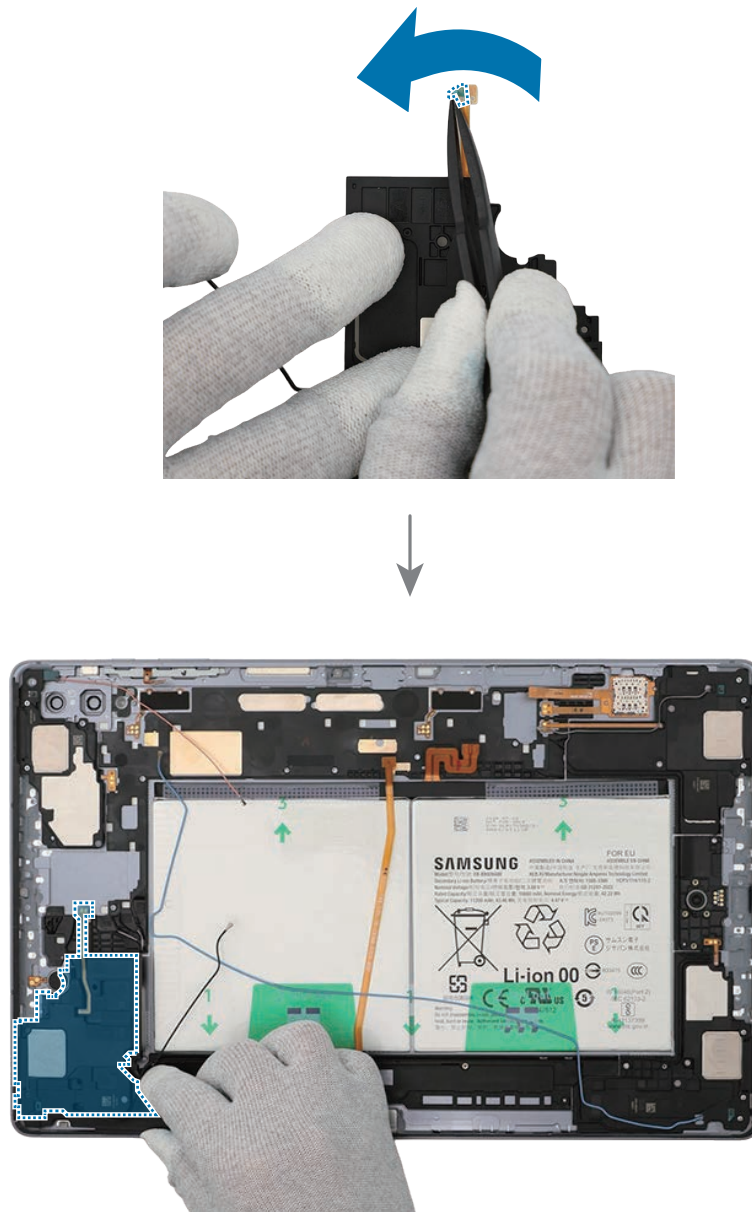

34 Using your fingers, press down softly and evenly on the speaker1 module and the FPCB so that the speaker1 module can be completely attached.

⚠ Be careful not to damage the speaker and cable.

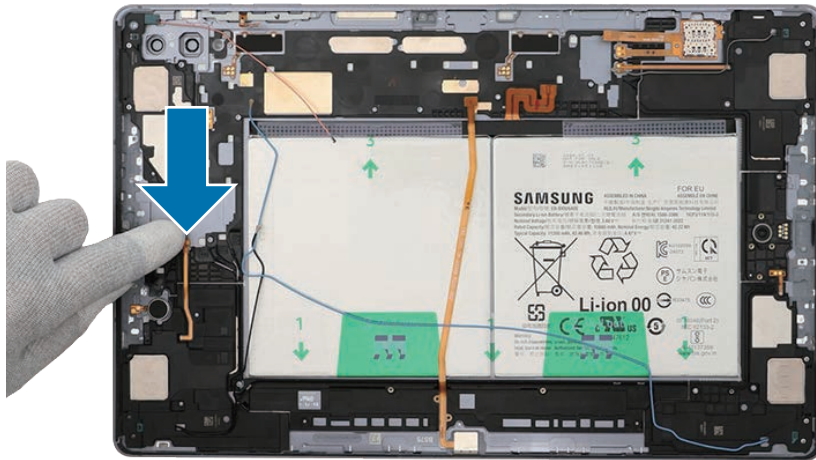
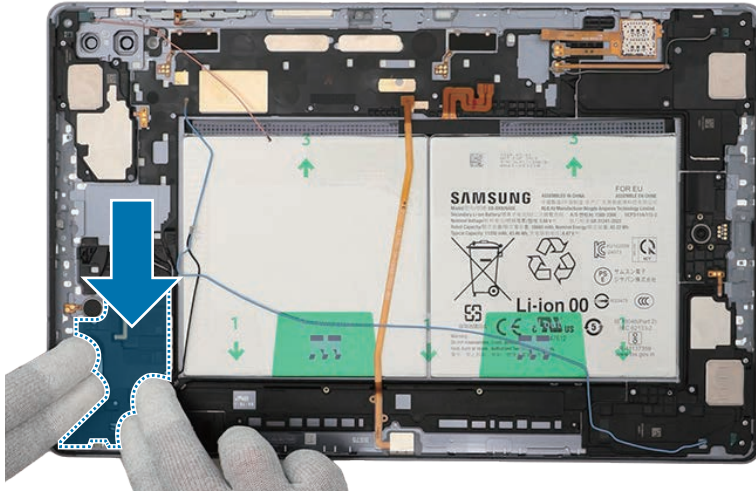

- 35 Check the screw 3405 (3 ea) and fasten them on the speaker1 using a cross-head screwdriver.

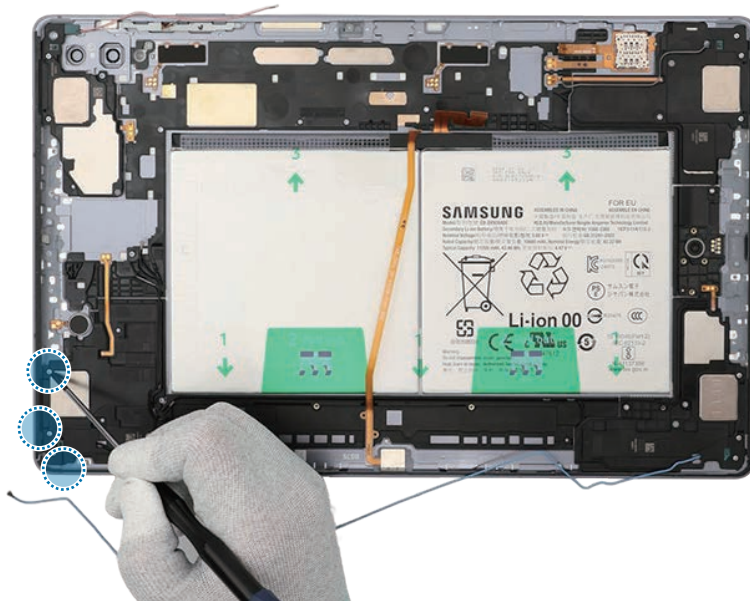

36 Using the tweezers, assemble the Wi-Fi board to the back cover module and press down softly and evenly on it so that the Wi-Fi board can be completely attached.

! Be careful not to damage the Wi-Fi board and near components.

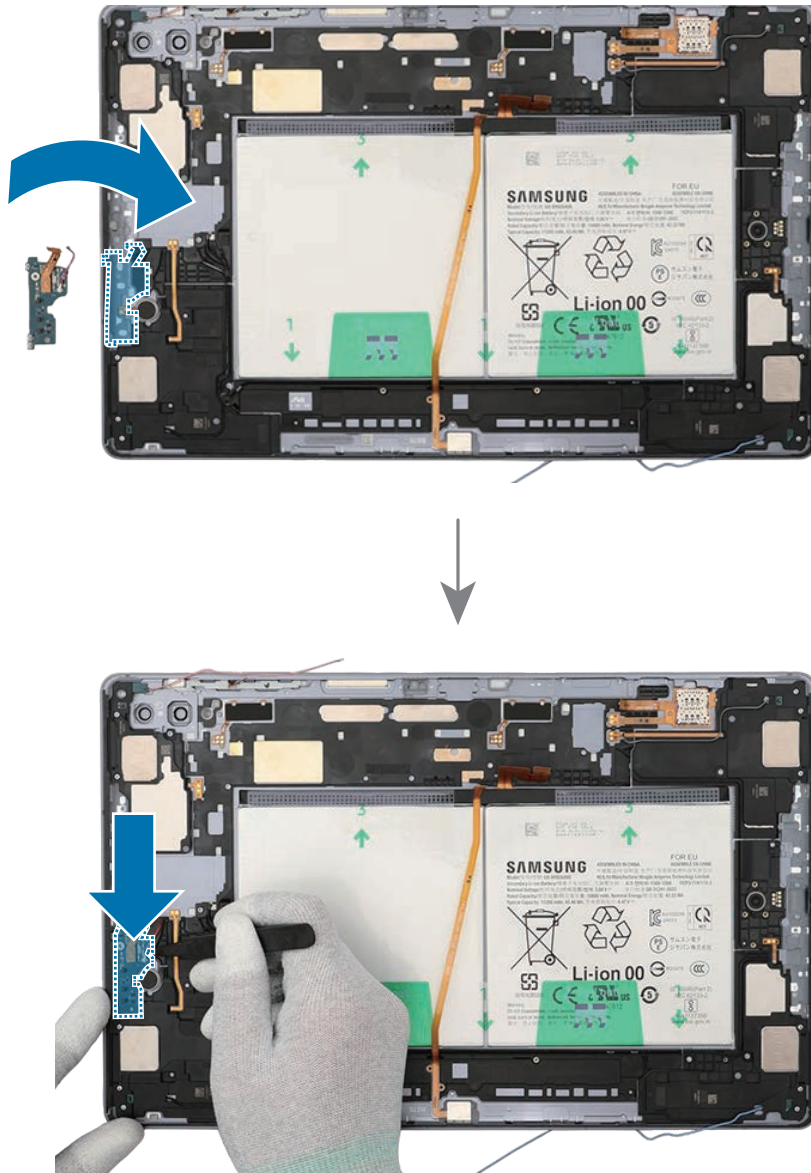

37 Check the screw 3443 (1 ea) and fasten it on the Wi-Fi board using a cross-head screwdriver.

⚠ Be careful not to damage the Wi-Fi board and near components.

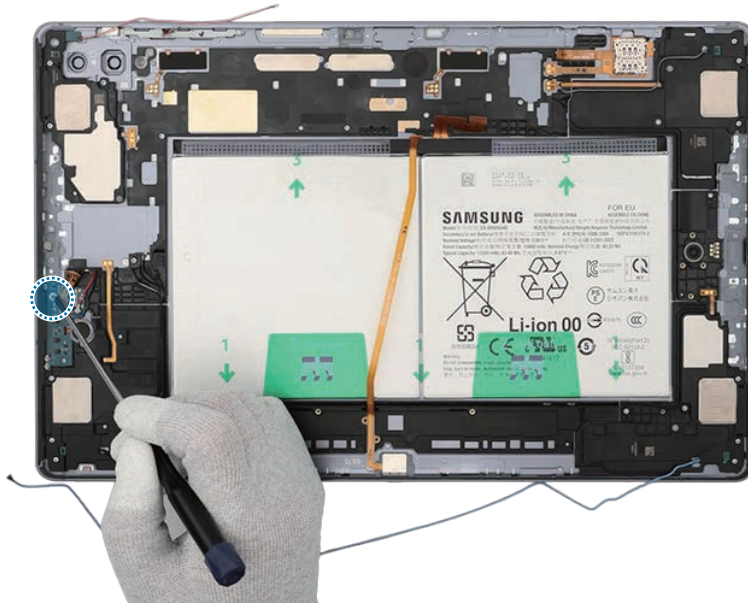

38 Using the tweezers, insert the charging port to the back cover module and press down softly and evenly on it so that the charging port can be completely attached.

- ❗ • Be careful not to damage the charging port module side contact.
- Be careful not to damage the near components.

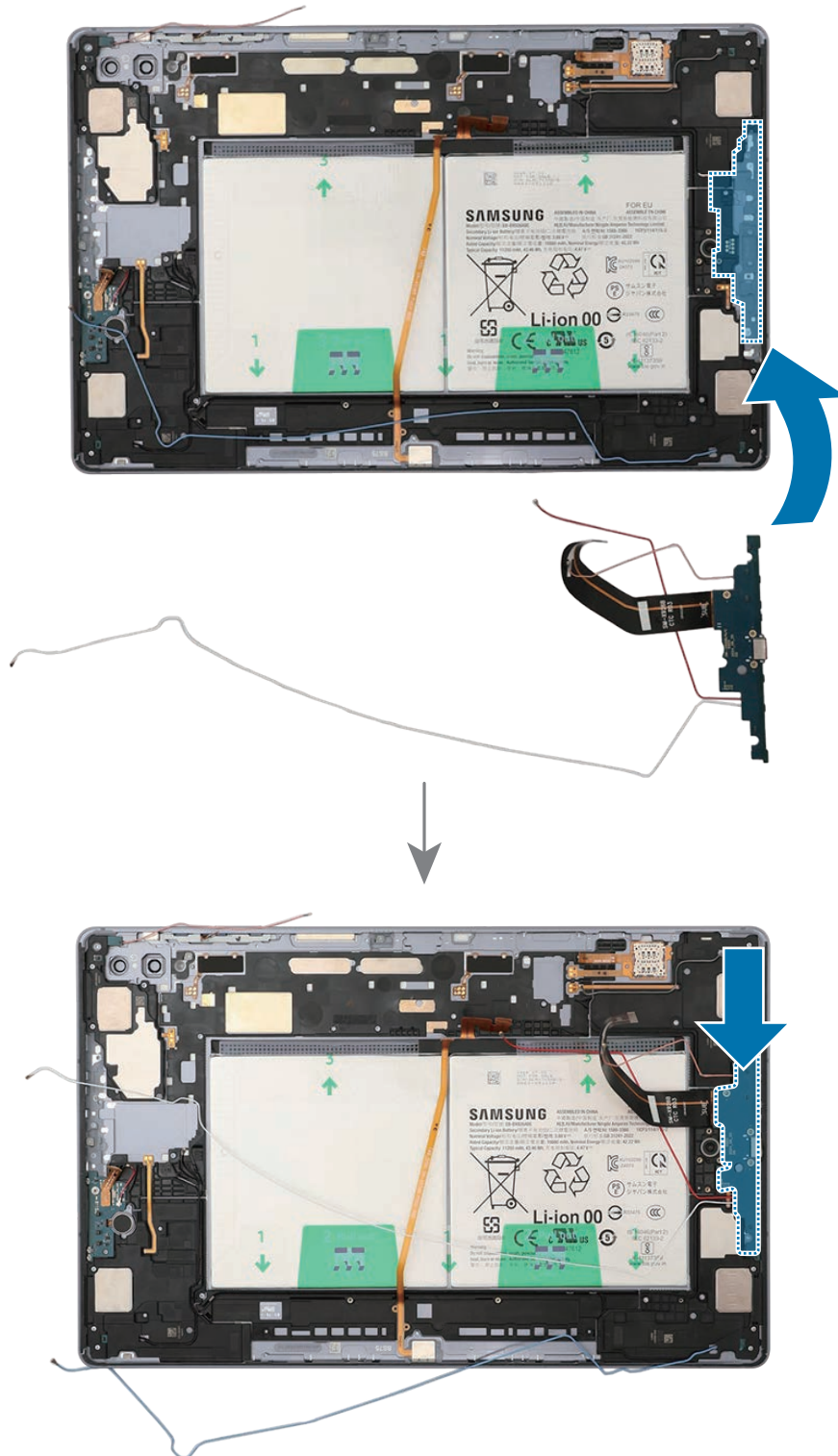

39 For the 5G or LTE devices, connect the 4 coaxial cables (Orange/Red/White/Blue) to the speaker modules carefully using the tweezers.

- ⚠ • Be careful not to damage the charging port and near components.
- Be careful not to damage the cables.
- 📄 • The 4 coaxial cables (Orange/Red/White/Blue) are only available for the 5G or LTE devices.
- The cables and connectors may vary depending on the country, region, or specifications.

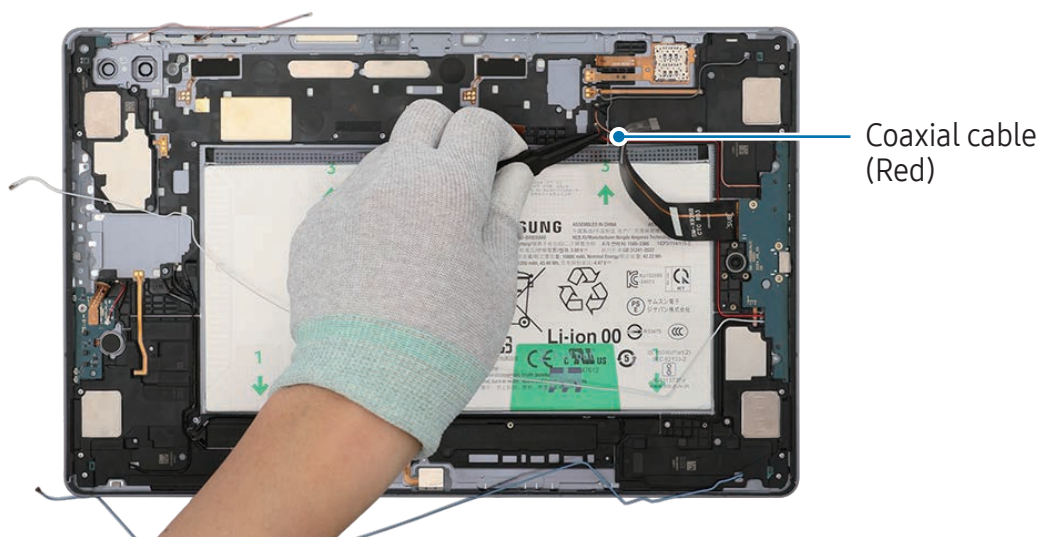

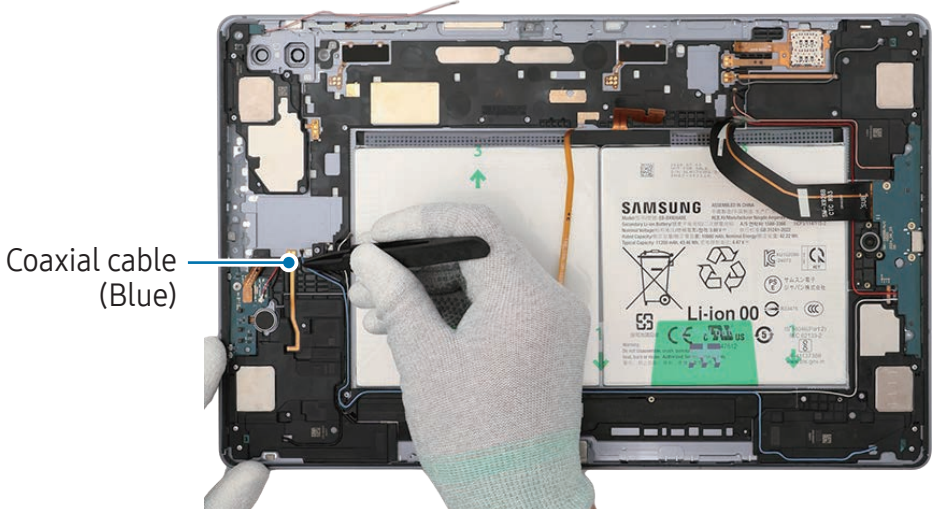
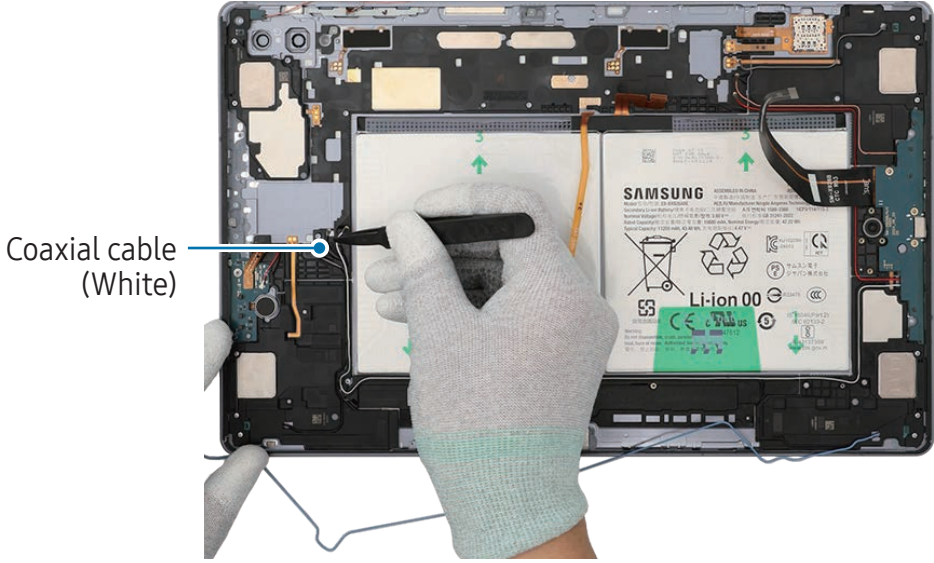

40 Check the screw 3443 (3 ea) and fasten them on the charging port using a cross-head screwdriver.

⚠ Be careful not to damage the charging port and near components.

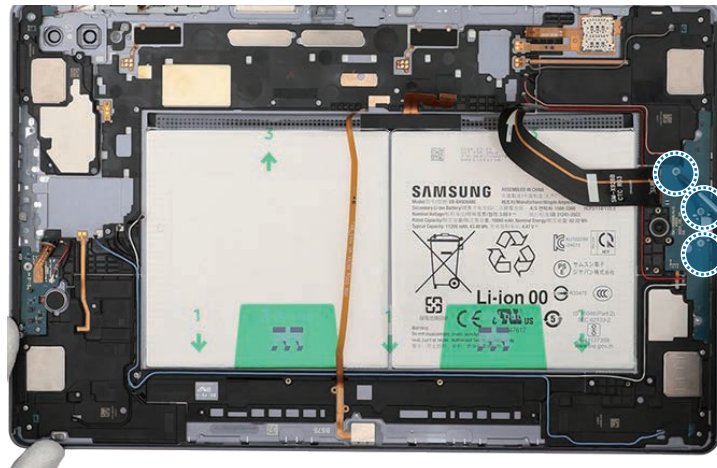

41 If you use the existing rear wide camera as it is, remove all adhesive tapes on the bottom of the camera using the tweezers.

- ⚠ • Be careful not to damage the camera lens.
- Be careful not to damage and scratch the camera module.

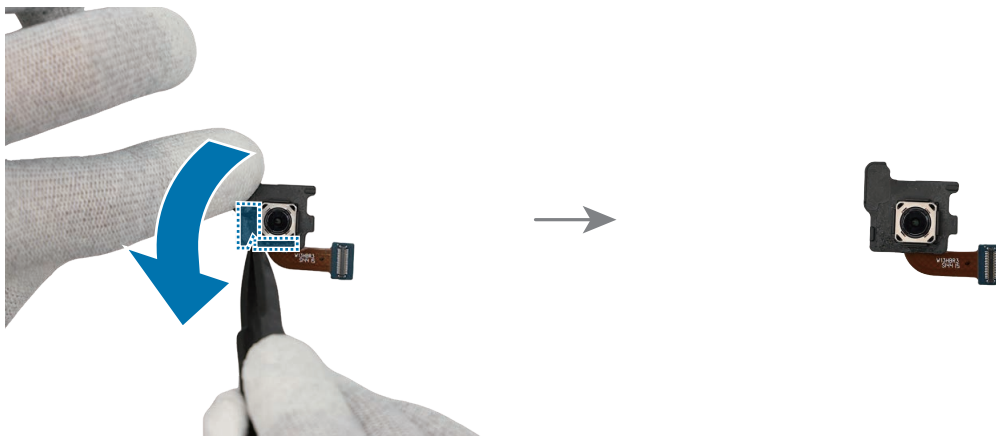

- 42 Using the tweezers, remove the release film from the new wide camera adhesive tape and attach it to the bottom of the wide camera.

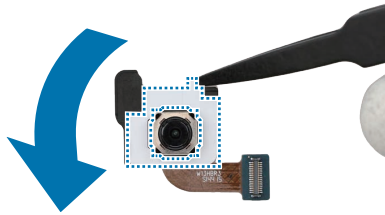

- 43 Using the tweezers, hold the protruding release film of the attached tape and carefully remove it.



44 Using the tweezers and your fingers, gently insert the wide camera in the camera hole so that the lens faces backward.

- ⚠ • Be careful not to damage the camera lens and near components.
- Be careful not to damage and scratch the camera module.

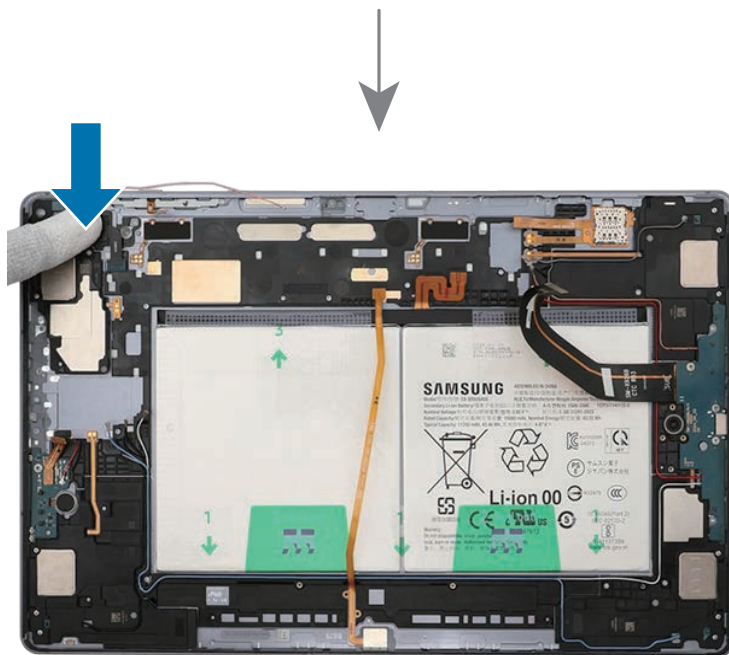
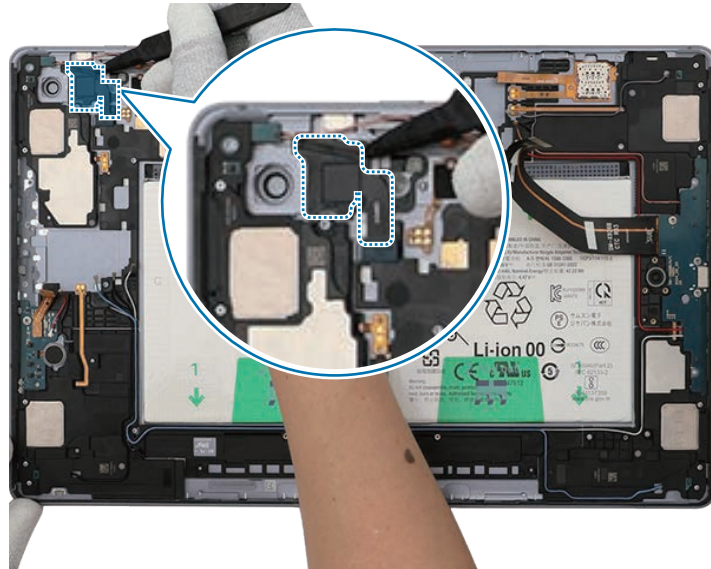

45 If you use the existing rear ultra wide camera as it is, remove all adhesive tapes on the bottom of the camera using the tweezers.

- ⚠ • Be careful not to damage the camera lens.
- Be careful not to damage and scratch the camera module.

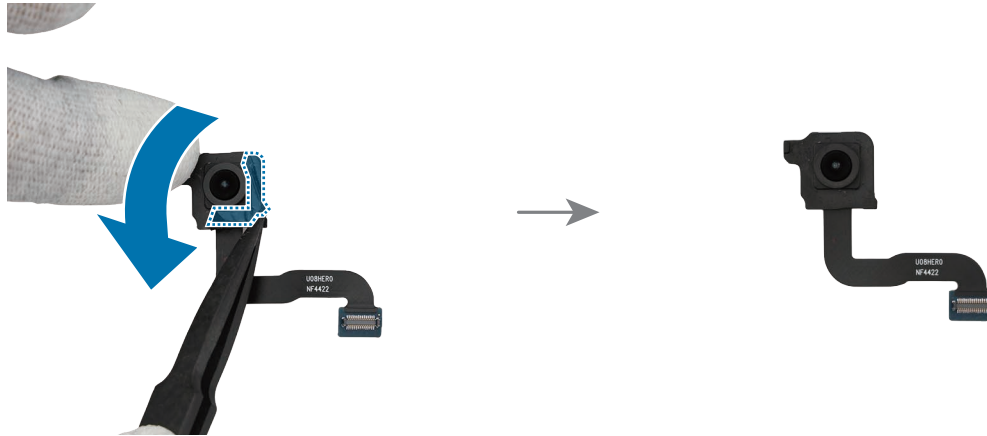

46 Using the tweezers, remove the release film from the new ultra wide camera adhesive tape and attach it to the bottom of the ultra wide camera.

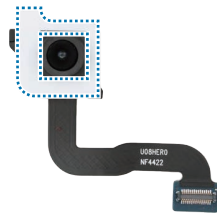

47 Using the tweezers, hold the protruding release film of the attached tape and carefully remove it.

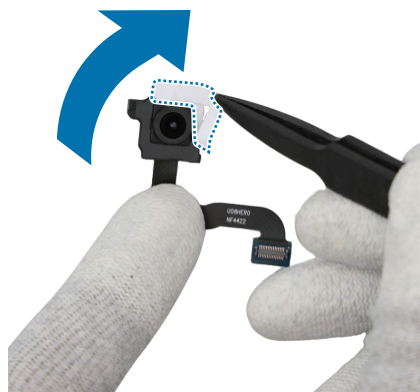

48 Using the tweezers and your fingers, gently insert the ultra wide camera in the camera hole so that the lens faces backward. Press down on the rear cameras with your fingers softly so that the cameras can be assembled completely.

- ⚠ • Be careful not to damage the camera lens and near components.
- Be careful not to damage and scratch the camera module.

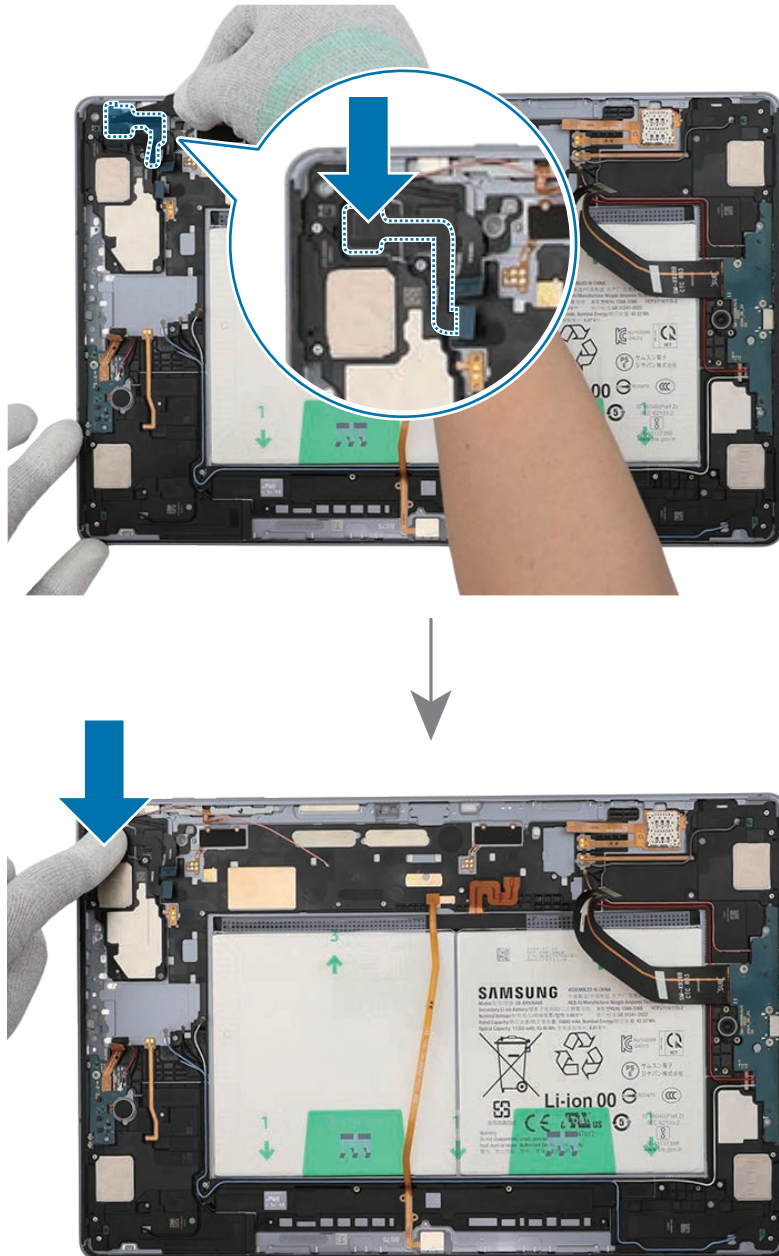

49 Place the main board to the exact position and assemble it to the back cover module.

- ❗ • The cables have to be positioned outside so as not to interfere when assembling the main board.
- Be careful not to damage the main board and near components.

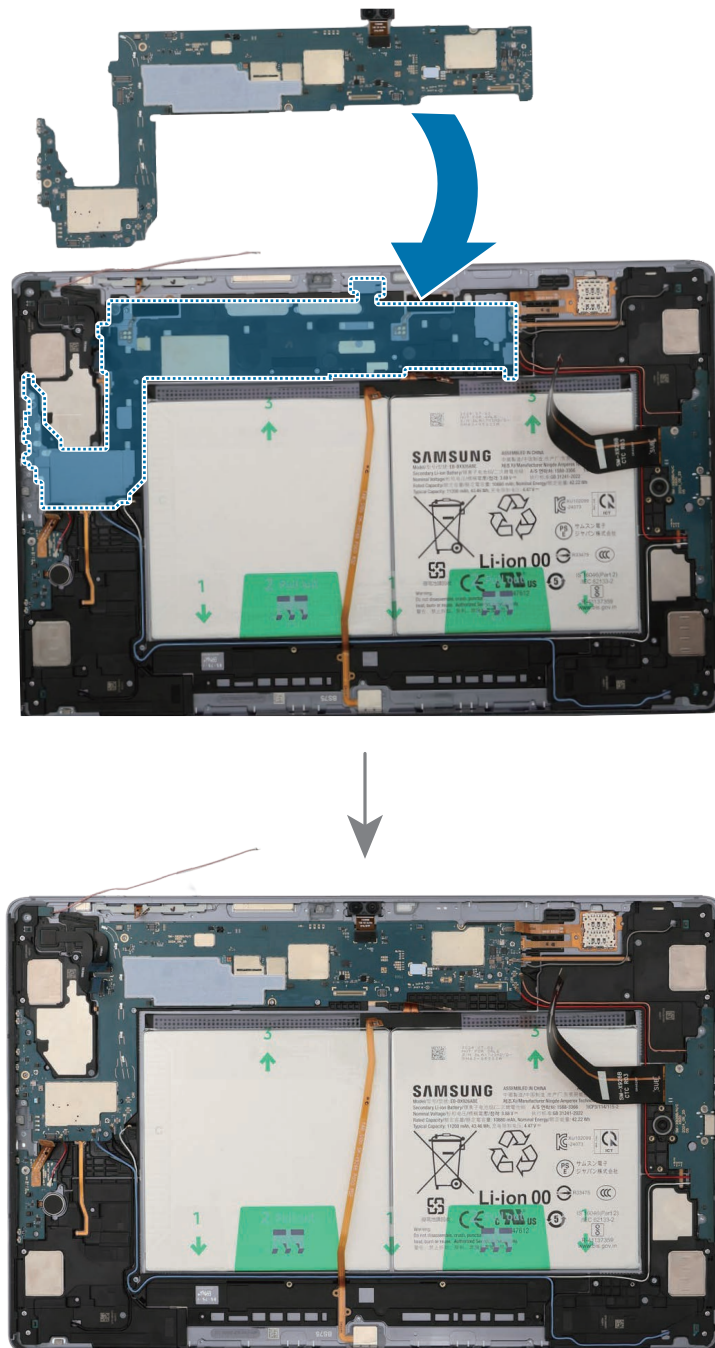

50 Using the tweezers, connect the coaxial cable (Orange) to the main board.

⚠ Be careful not to damage the cables and near components.

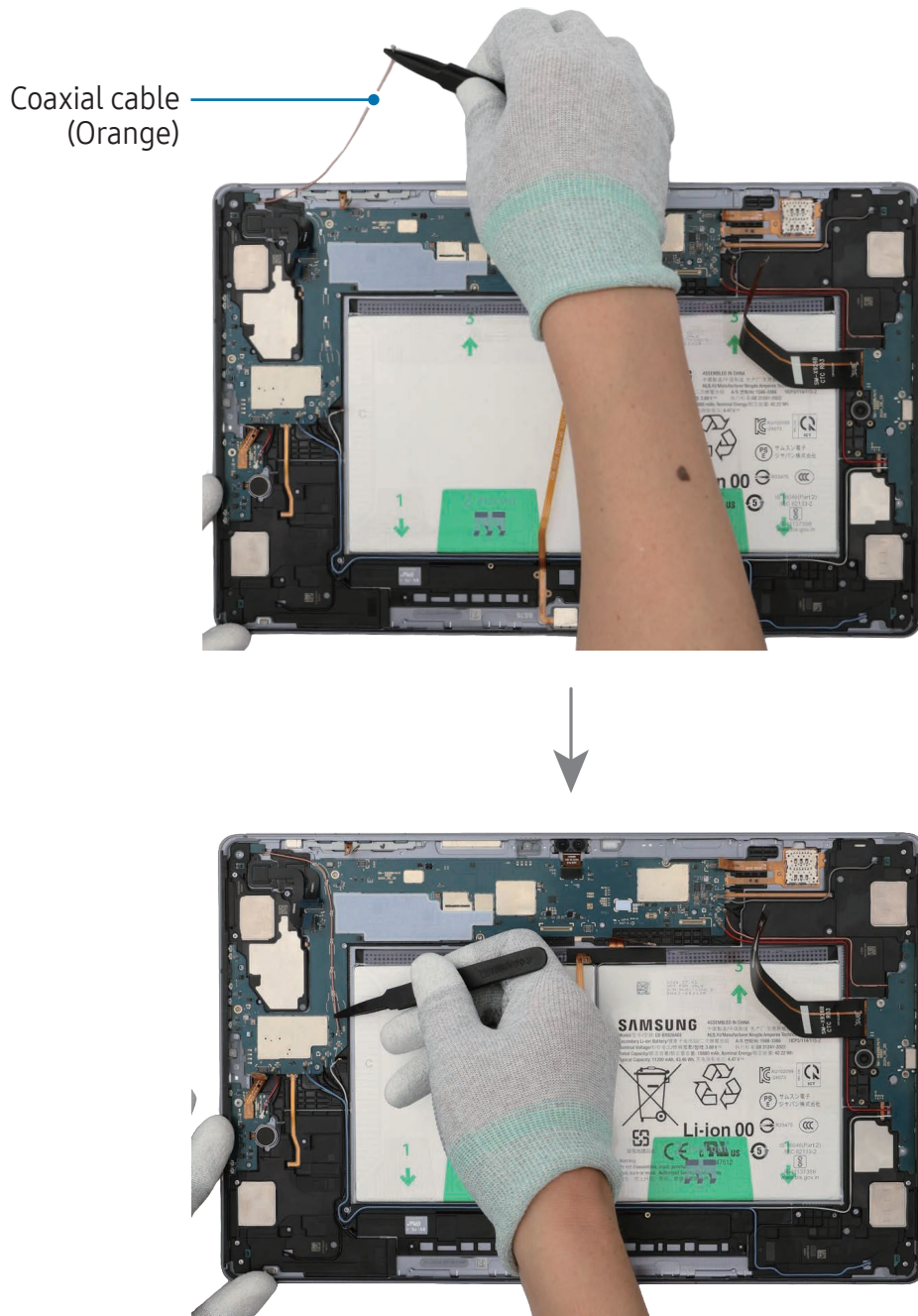

51 Check the screw 3463 (4 ea) and fasten them on the main board using a cross-head screwdriver.

⚠ Be careful not to damage the main board and near components.

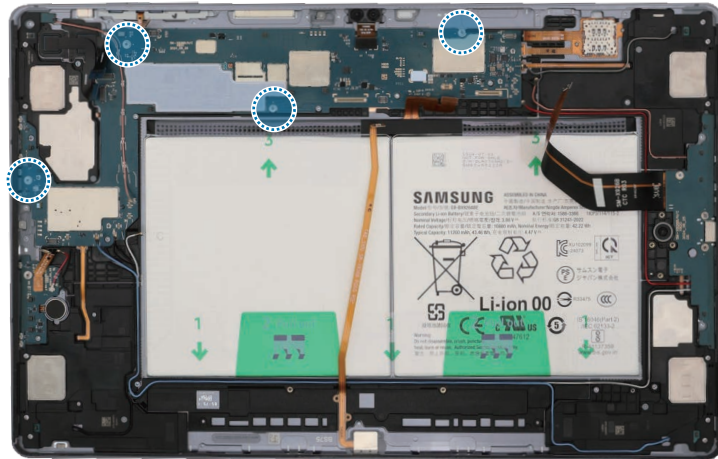

52 Using the tweezers, connect the 8 connectors and the 3 coaxial cable connectors (Orange/Black/Red) to the main board. For the 5G or LTE devices, connect the additional 5 coaxial cable connectors (Blue/White/Grey/Orange/Red).

⚠ Be careful not to damage the battery.

⚠

- Be careful not to damage the cable while connecting the connectors.
- Be careful not to damage the near components.

📄

- The 5 coaxial cables (Blue/White/Grey/Orange/Red) are only available for the 5G or LTE devices.
- The cables and connectors may vary depending on the country, region, or specifications.

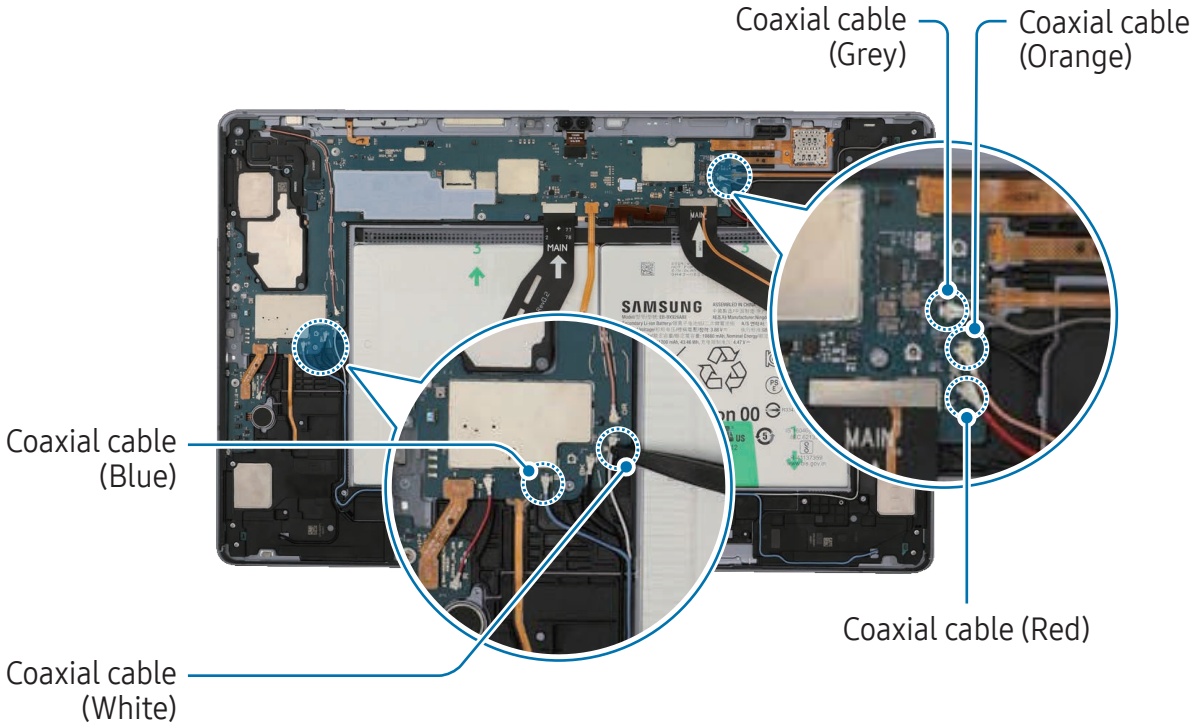
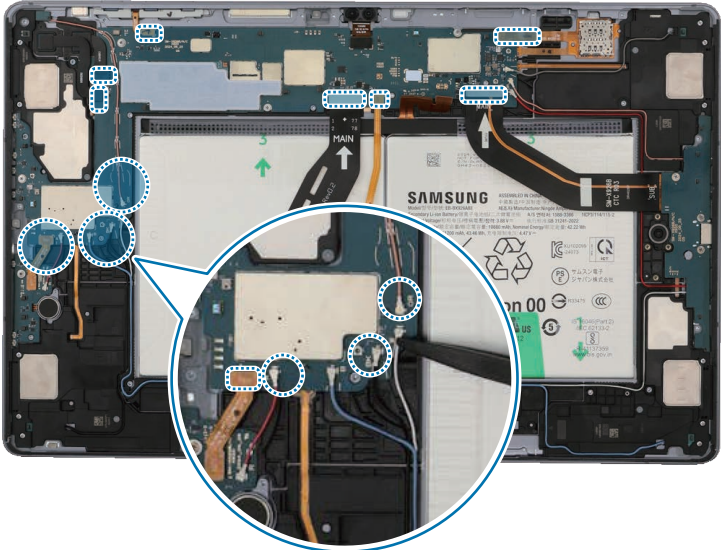

53 Connect the battery connector to the main board.

⚠ Be careful not to damage the battery.

⚠ Be careful not to damage the battery connector and near components.

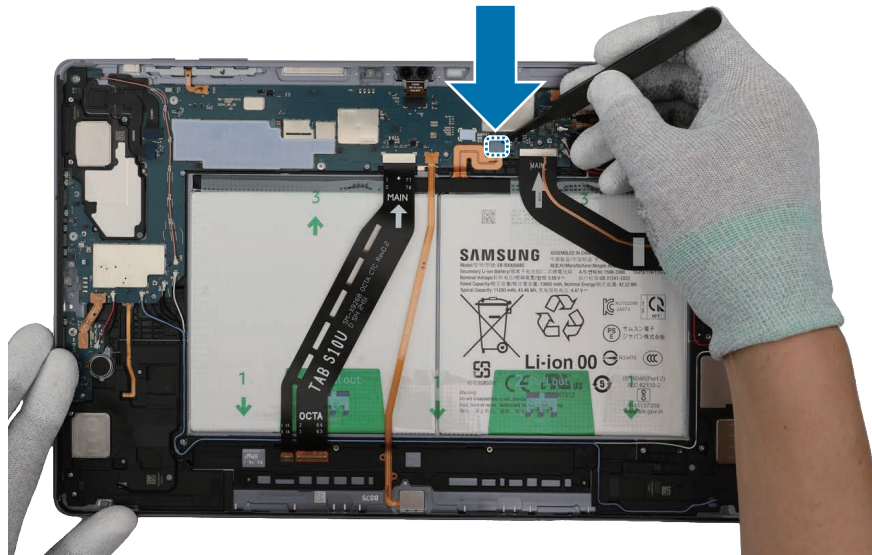

🔧 Reassemble the [Bracket](#), [Screen](#) and [SIM Card Tray](#) to complete assembly.

After reassembling

- Check whether the parts or sensors in the device work properly with the Self Repair Assistant app after repairing and assembling your device. Refer to [Calibrations](#) for more information.
- Visit a Samsung Service Centre when finding some issues from the calibration results. However, you may incur additional charges if the device has a malfunction because of DIY repairs.

Directive 2012/19/EU Annex VII Components

Directive 2012/19/EU Annex VII requirements apply to the following components.

Component	Samsung Part Name	Removal Instructions
Printed circuit board if the surface is greater than 10 square centimetres	Main Board (PBA)	In the Front Camera disassembly step, after disassembling the front camera, check for the disassembly steps of the Speaker1 and separate the main board.
Liquid crystal display of a surface greater than 100 square centimetres and all those back-lighted with gas discharge lamps	Screen	Check for the disassembly steps of the Screen and separate the screen.
Battery	Battery	Check for the disassembly steps of the Battery and separate the battery.
External electric cable	USB Cable	Disconnect the USB cable.

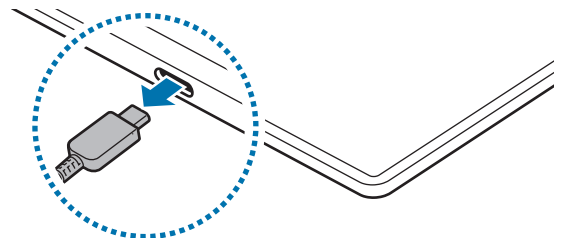

SAMSUNG

This guide is a property of Samsung Electronics Co., Ltd.

Any unauthorised use of guide can be punished under applicable international and/or domestic law.

© Samsung Electronics Co., Ltd.

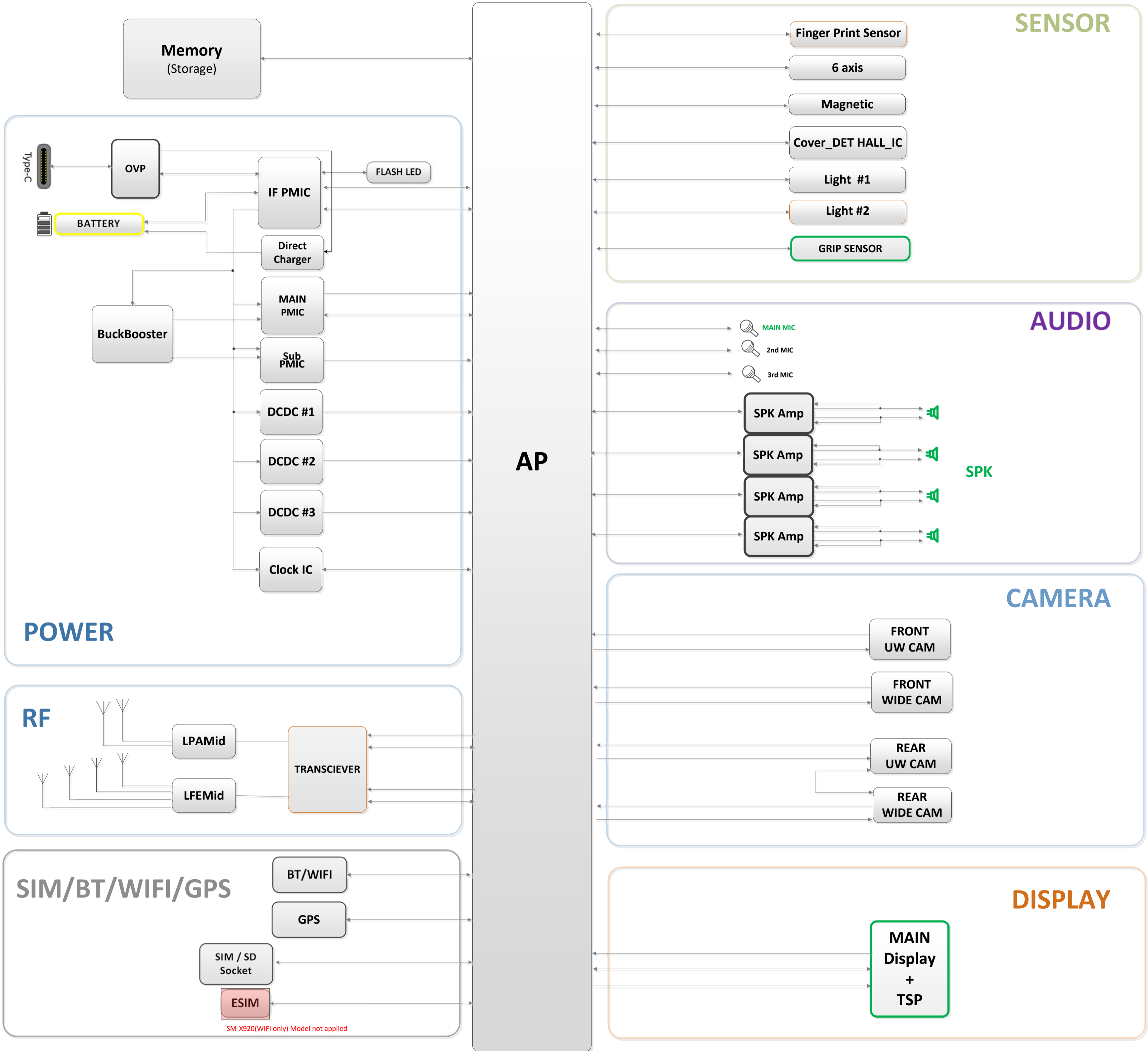

SM-X920(WIFI only) Model not applied