

K1 Max/ K1 Max2025 User Manual



3D Printer User Manual

V1.0

Dear Users

Thank you for choosing our products. For the best experience, please read this User Manual carefully and strictly follow the instructions to operate the printer. Our teams will always be ready to provide you with the best services. Please contact us via the phone number or e-mail address provided at the end of this User Manual when you encounter any problem with the printer. For a better experience in using our products, you can also learn how to use the printer in the following ways: Accompanied instructions: you can find the relevant instructions and videos on the USB flash disk.

You can also visit our official website (<https://www.creality.com> [🔗](#)) to find information regarding software, hardware, contact information, device instructions, device warranty information, and more.

Dear **Users**

Thank you for choosing Creality products. This quick guide introduces the steps for unboxing, installation, and debugging. Please read it carefully before use.

For more detailed instructions, unboxing videos, and after-sales service tutorials, please visit the Creality Wiki platform.

The Creality team is always ready to provide you with quality service. If you encounter any problems during use, please contact us through the phone number and email provided at the end of this quick guide.

Bought a product but don't know how to use it? Don't worry, all your confusions will be resolved!

<https://wiki.creality.com>



- ✓ Comprehensive understanding of the new product, immersive exploration of its features.
- ✓ Detailed operation guides to help you get started effortlessly.
- ✓ Professional after-sales support platform offering efficient solutions.



Creality official Wiki

Creality Cloud – Your 3D Printing Universe Awaits! Discover the all-in-one 3D printing platform designed for all enthusiasts.

<https://www.crealitycloud.com>



- ✓ Access a vast library of high-quality models.
- ✓ Built-in cloud slicing and Print Settings make printing easier than ever.
- ✓ Control remotely and print with just one click, anytime, anywhere.



Creality Cloud App

NOTES

1. Do not use the printer in any way other than described herein in order to avoid personal injury or property damage;
2. Do not place the printer near any heat source or flammable or explosive objects. We suggest placing it in a well-ventilated, cool and dustless environment;
3. Do not expose the printer to a violent vibration or any other unstable environment, as this may cause poor print quality;
4. Please use recommended filaments to avoid clogging of the extrusion head and causing damage to the machine;
5. Do not use the power cable of other products during installation. Always use a grounded three-prong power outlet, which accompanies the printer;
6. Do not touch the nozzle and the heated bed during operation to avoid burns or personal injury;
7. Do not wear gloves or wraps while operating the machine to prevent entrapment of movable parts that could cause crushing and cutting injuries to bodily parts;
8. Use the provided tools to clean the filament from the extruder in time taking advantage of the residual temperature after printing. Do not touch the extruder directly when cleaning, otherwise it may cause burns;
9. Clean the printer frequently. Clean the printer body with a dry cloth regularly after powering off the printer, wipe away dust, bonded print filament and foreign objects on the guide rails;
10. Children under 10 years old should not use the printer without supervision, otherwise it may cause personal injury;
11. Users should comply with the laws and regulations of the corresponding countries and regions where the equipment is located (used), abide by professional ethics, pay attention to safety obligations, and strictly prohibit the use of our products or equipment for any illegal purposes; Creality will not be responsible for any violators' legal liability under any circumstance;
12. Tip: Do not plug in or unplug wires on a charged basis.

1. About the Device

1.1 About the Printer K1 Max/K1 Max2025

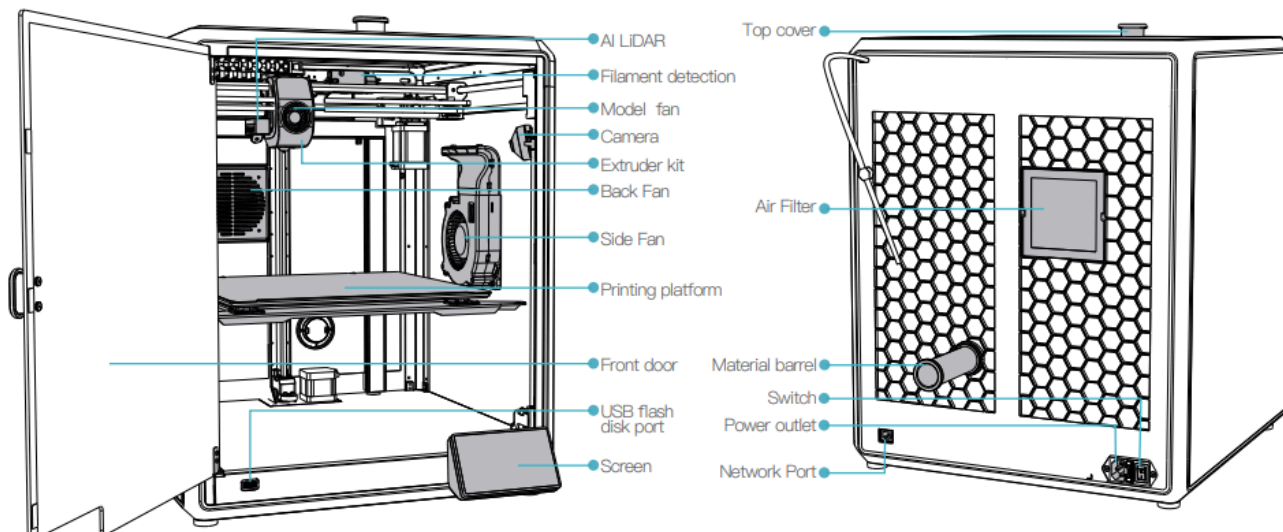

1.2 Device Specifications for K1 Max

Basic Parameters	
Product Model	K1 Max
Dimensions	435*462*526mm
Max. Build Dimensions	300*300*300mm
Print Technology	FDM
Rated Voltage	100–240V~, 50/60Hz
Rated Power	1000W
Ambient temperature	10°C–30°C / 50°F–86°F
Extruder	Sprite Direct Drive
Supported Filament	PLA/ABS/Carbon/PETG/PET/TPU95A
Max. Heated Bed Temperature	120°C
Max. Nozzle Temperature	300°C
Screen	4.3 inch touch screen
Printing Method	USB Flash Disk/LAN Printing/Creality Cloud Printing
Connection	USB flash disk/WIFI/Ethernet
Power Loss Recovery	Yes
Filament Detection	Yes
Auto leveling	Yes
Camera	Yes
AI LIDAR	Yes

1.2 Device Specifications for K1 Max 2025

Basic Parameters	
Product Model	K1 Max 2025
Dimensions	435*462*526mm
Max. Build Dimensions	300*300*300mm
Print Technology	FDM
Rated Voltage	100–240V~, 50/60Hz
Rated Power	1000W
Ambient temperature	10°C–30°C / 50°F–86°F
Extruder	Sprite Direct Drive
Supported Filament	PLA/ABS/Carbon/PETG/PET/TPU95A
Max. Nozzle Temperature	300°C
Screen	4.3 inch touch screen
Printing Method	USB Flash Disk/LAN Printing/Creality Cloud Printing
Connection	USB flash disk/WIFI/Ethernet
Power Loss Recovery	Yes
Filament Detection	Yes
Auto leveling	Yes
Camera	Yes
AI LiDAR	Yes

1.3 K1 Max/K1 Max2025 Packing List

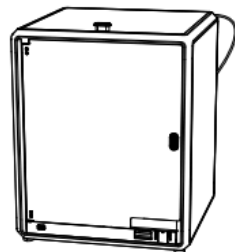

1 Printer



2 Screen



3 Filament

Tool Box List



4 Wrench and Screwdriver x1



5 Blade x1



6 Material barrel x1



7 Cutting plier x1



8 1.2mm nozzle cleaner x1



9 USB flash disk x1



10 Lubricating Grease x1



11 Power Cable x1



12 M6 socket spanner x1



13 Glue Stick x1



14 Damping Pads x4

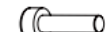

15 Belt tensioning screw M3x12 x2



16 Quick Guide x1



17 After-sales Services Card x1

* Tips: the above accessories are for reference only. Please refer to the physical accessories!

2. Unbox Video

[K1 Max Operation Video](#) 

2.1 Unpacking Steps

Take the packing cotton and tools in the order as shown in figure.

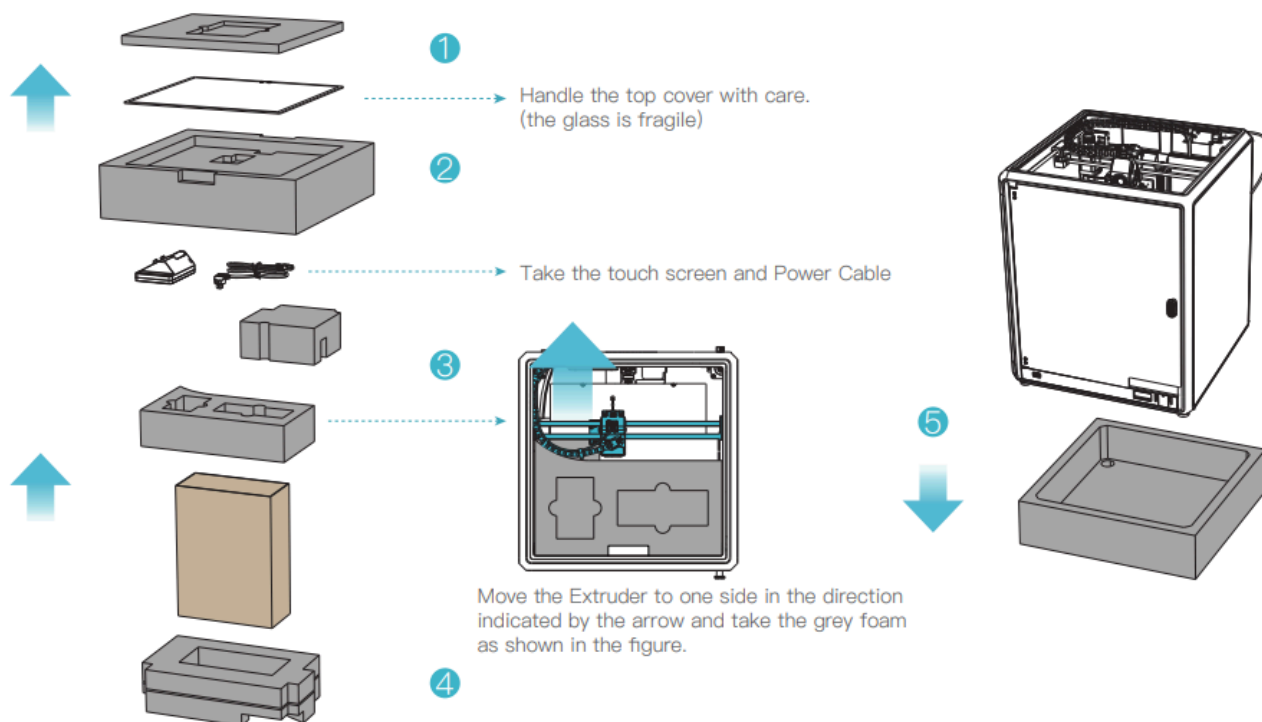

2.2 Install the Product for K1 Max

① connect the touch screen to the flat cable extended from the base according to Figure A. Then snap the touch screen into the slot in the baseplate, as shown in Figure B. (The direction is as shown in the figure; otherwise, the screen interface may be damaged.)

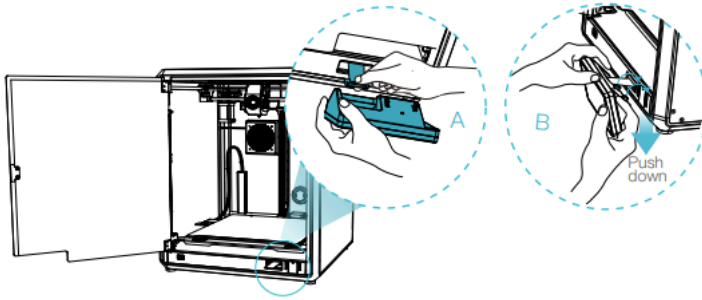

Caution:

- Do not power up the machine while you are connecting or disconnecting the touch screen.
- The flexible flat cable of the base is pulled lightly and broken carefully.

② A.Connection and power on.
B.Install the material barrel.

③ Load filaments.(Insert the filaments into the deepest part of Teflon tube until it cannot be moved.)

④ Install the top cover.(Put the top cover gently on the top of the machine.)

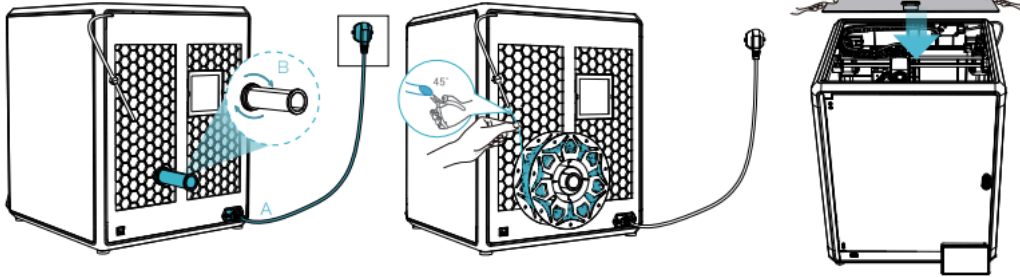

Caution:

- When printing low-temperature filaments such as PLA and flexible filaments, remove the clear top cover if the room temperature exceeds 30°C.
- When printing high melting-point filaments such as non-PLA and non-flexible filaments, be sure to keep the forming chamber temperature with the clear top cover closed to avoid cracking of the mould.

⑤ Select a language and click "Next", Remove three screws a, b and c according to position indicated by the yellow arrow. click "OK" on the screen.

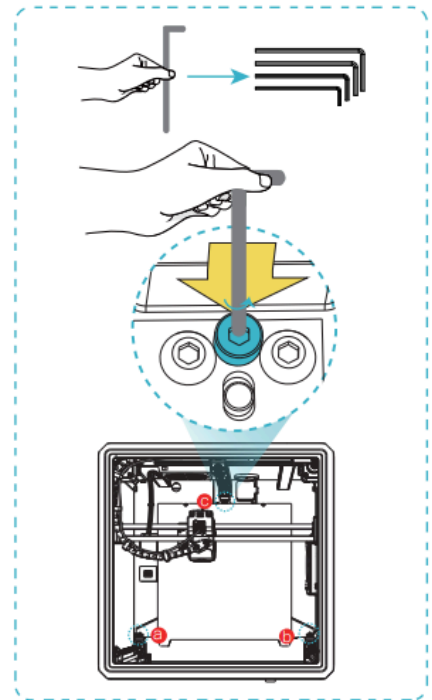
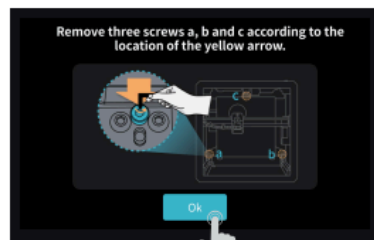

⑥ Keep the blue cube in the figure clean of debris and then click "OK".

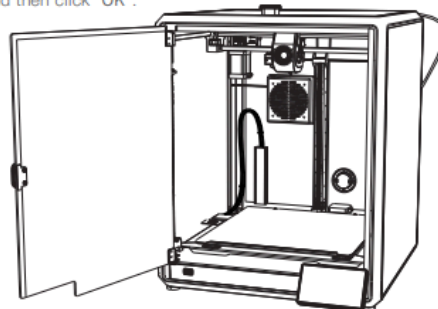

2.2 Install the Product for K1 Max 2025

- ① connect the touch screen to the flat cable extended from the base according to Figure A. Then snap the touch screen into the slot in the baseplate, as shown in Figure B. (The direction is as shown in the figure; otherwise, the screen interface may be damaged.)

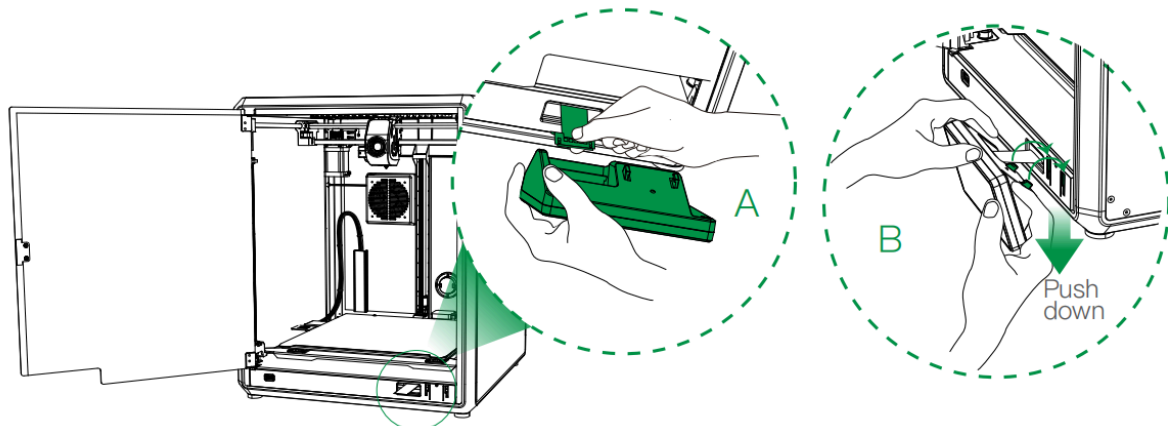

Caution:

- Do not power up the machine while you are connecting or disconnecting the touch screen.
- The flexible flat cable of the base is pulled lightly and broken carefully.

- ② A: Connection and power on.
B: Install the material barrel.

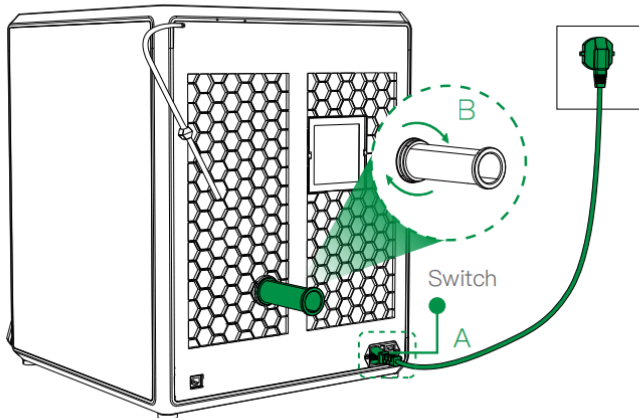

- ③ Load filaments.
(Insert the filaments into the deepest part of Teflon tube until it cannot be moved.)

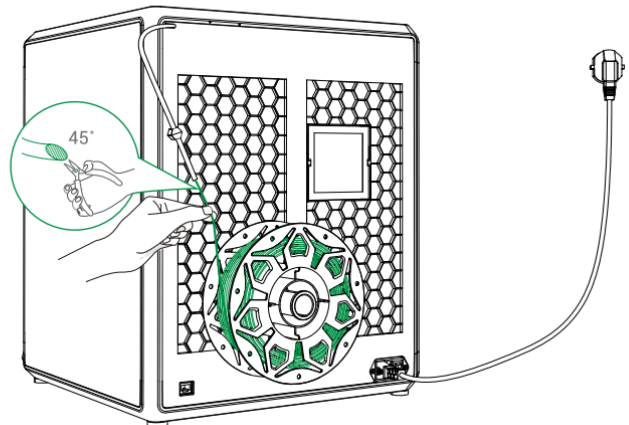

- ④ Install the top cover. (Put the top cover gently on the top of the machine.)

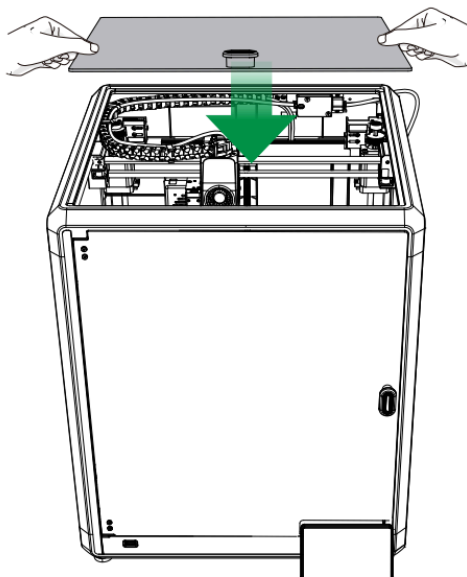

Caution:

- When printing low-temperature filaments such as PLA and flexible filaments, remove the clear top cover if the room temperature exceeds 30°C.
- When printing high melting-point filaments such as non-PLA and non-flexible filaments, be sure to keep the forming chamber temperature with the clear top cover closed to avoid cracking of the mould.

⑤ Select a language and click “Next”, Remove three screws a, b and c according to position indicated by the yellow arrows. click “Next” on the screen.

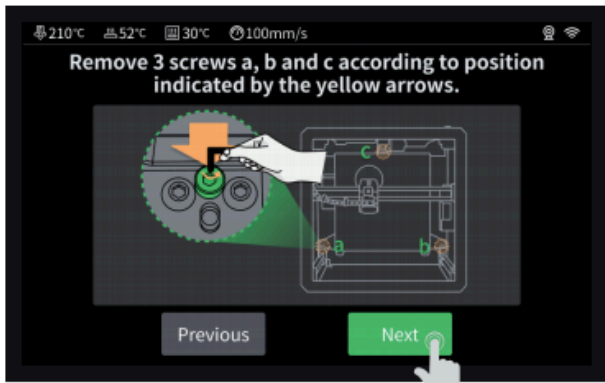
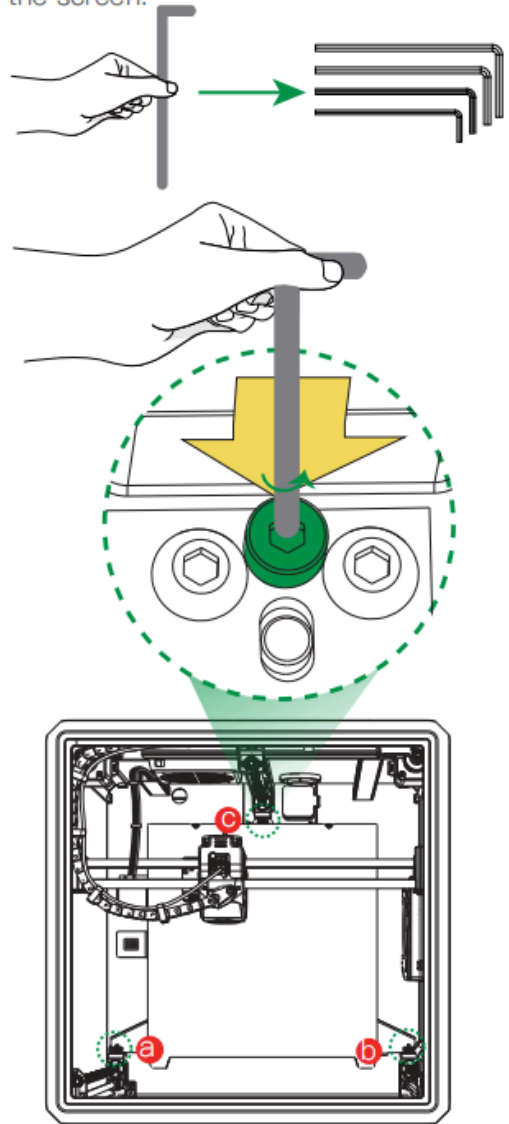
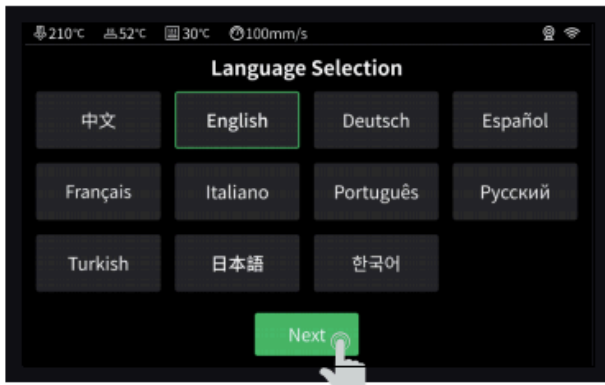

⑥ Keep the green cube in the figure clean of debris and then click “Next”.

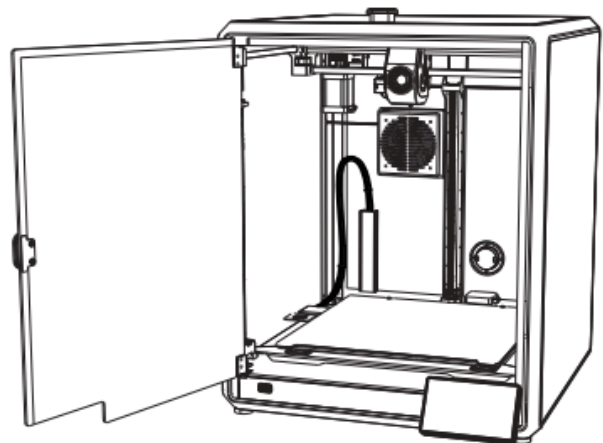
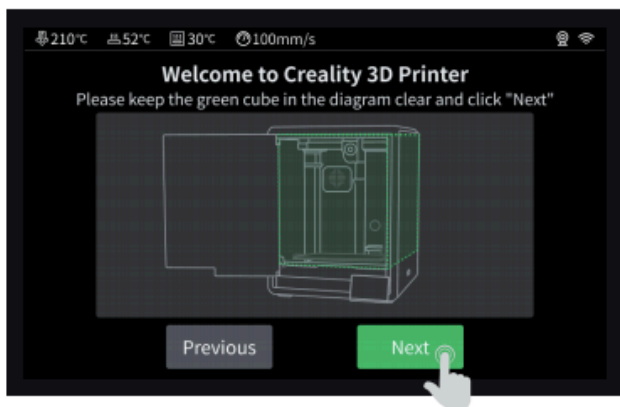

2.3 K1 Max Power-on guide

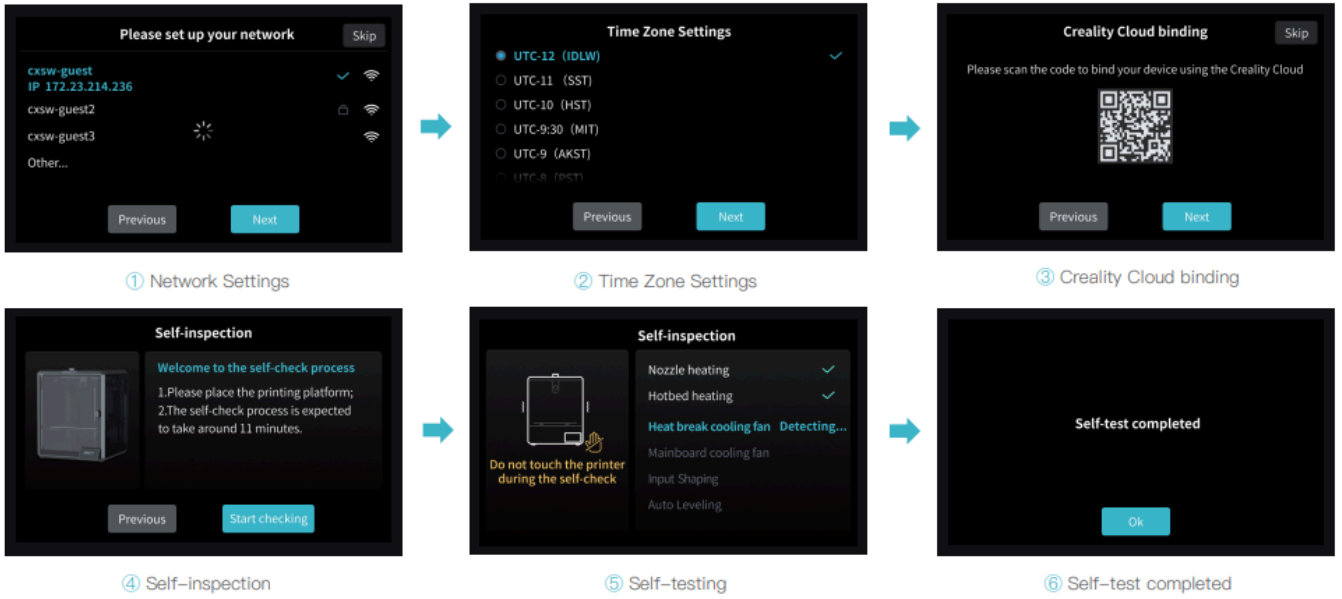

Note: The current interface is for reference only. Due to the continuous upgrading of functions, it shall be subject to the latest firmware UI published on the official website.

3. About K1 Max User Interface

3.1 Tune、Prepare

3.1 Tune、Prepare

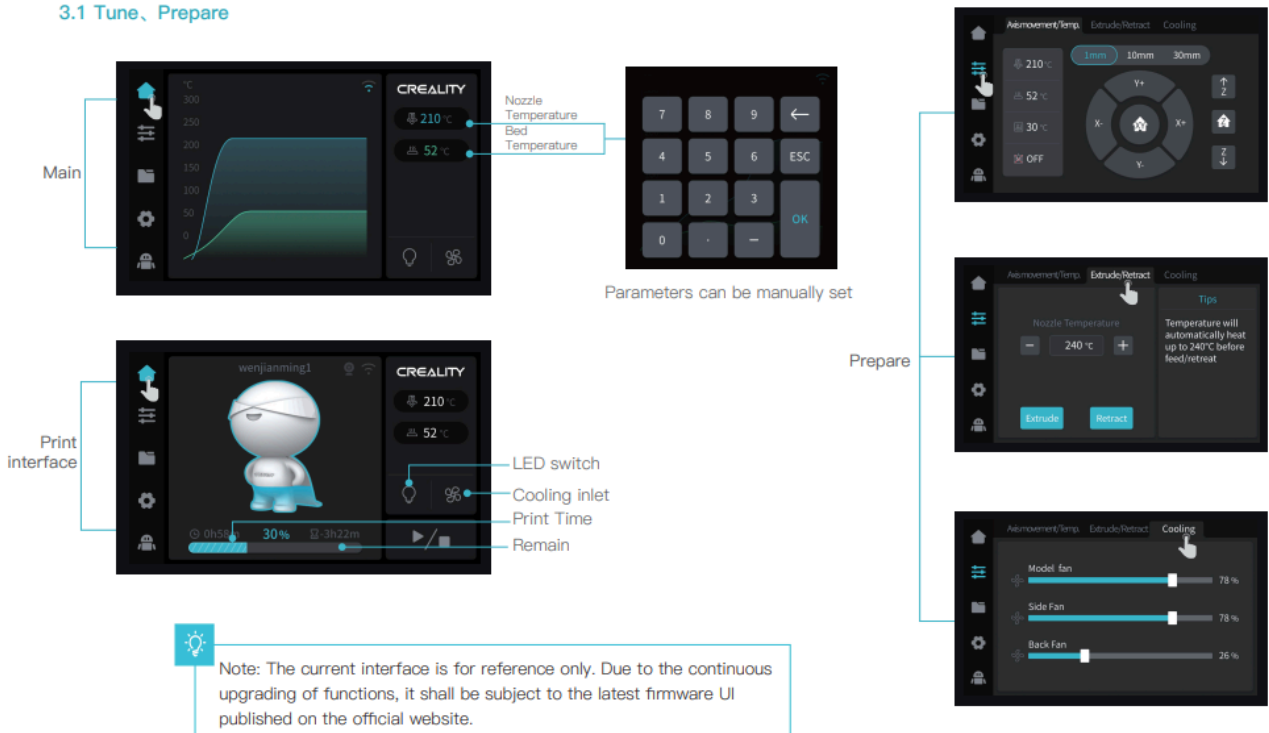

3.2 Files



① Local model

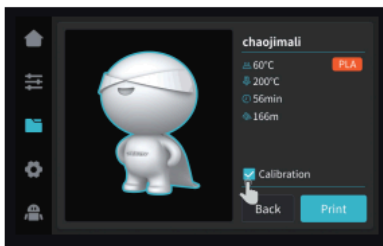

② Printing

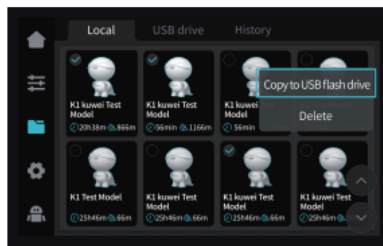

③ Press and hold on the model to multi-select and copy it to a USB flash drive



④ USB flash drive model

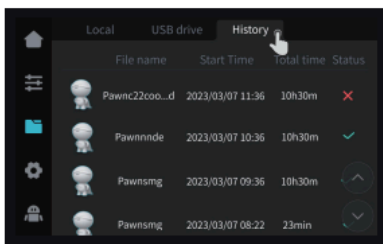

⑤ History

Note: The current interface is for reference only. Due to the continuous upgrading of functions, it shall be subject to the latest firmware UI published on the official website.

3.3 Tune、Support

3. About the User Interface

3.3 Tune、Support

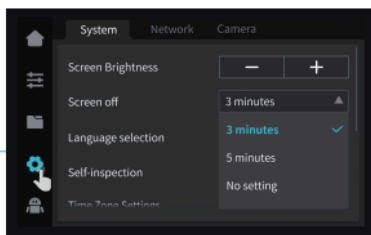

System

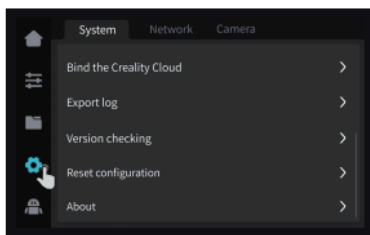

System

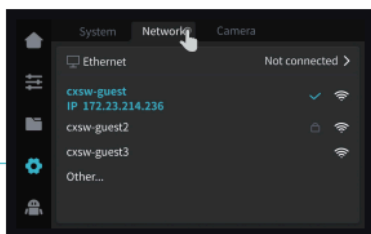

Network

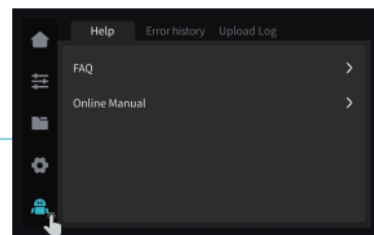

Help

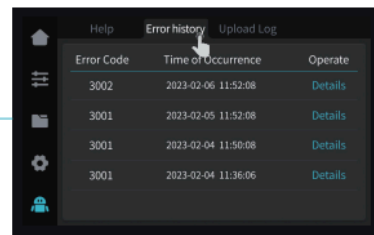

Error history

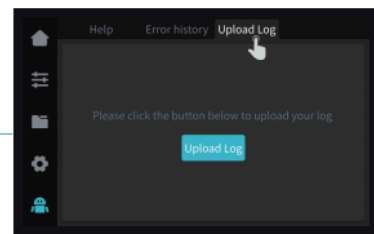

Upload Log

Note: The current interface is for reference only. Due to the continuous upgrading of functions, it shall be subject to the latest firmware UI published on the official website.

4. K1 Max First Printing

4.1 Local Printing

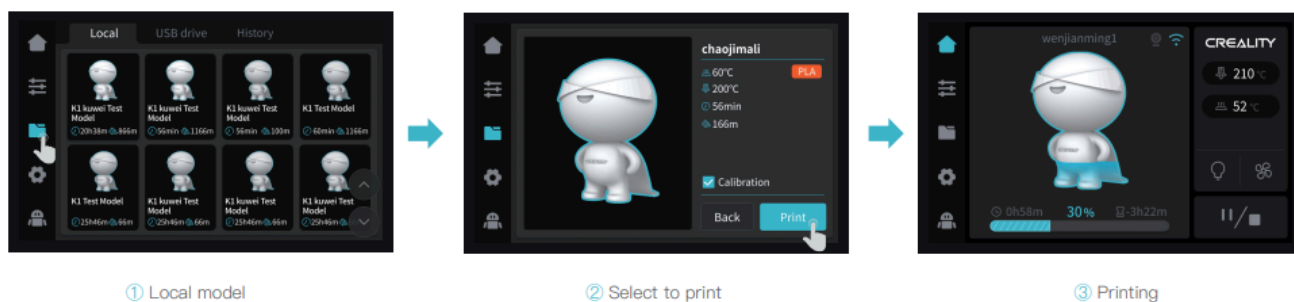

Note: The current interface is for reference only. Due to the continuous upgrading of functions, it shall be subject to the latest firmware UI published on the official website.

4.2 LAN Printing

Creality Print



① Download at (www.crealitycloud.com) or find the software on a USB flash drive and install it.

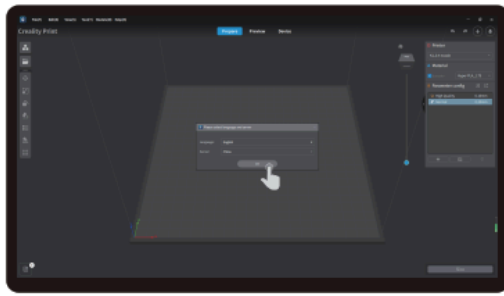

② Choose a language and region

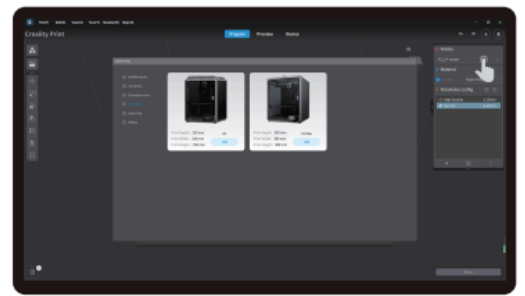

③ Choose a Printer

💡 Tips: the computer must be in the same local area network as the printer

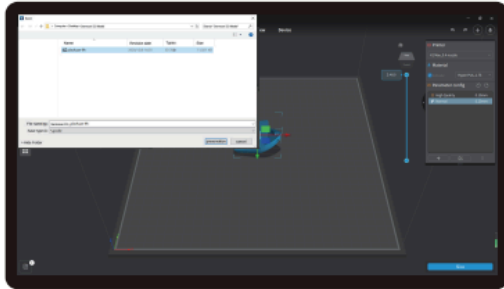

④ Click on "Import Model" and select the model file

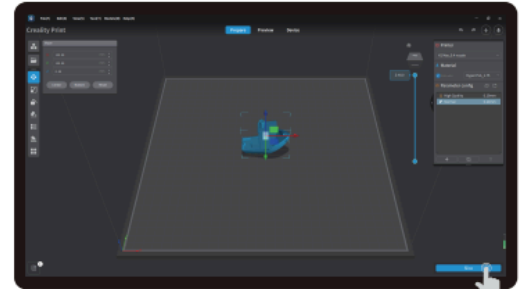

⑤ Open the model and click on "Start Slicing"

💡 Note: The current interface is for reference only. Due to the continuous upgrading of functions, it shall be subject to the latest firmware UI published on the official website.

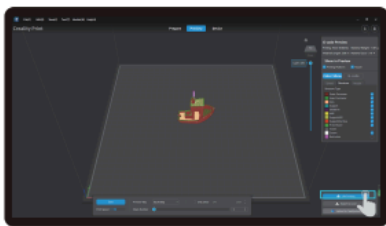

⑥ Selection of LAN printing

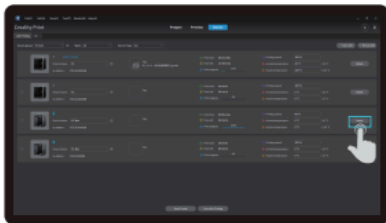

⑧ Device List

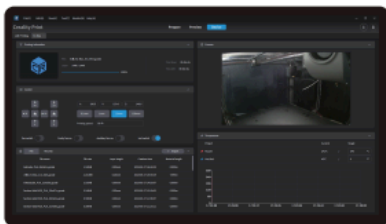

⑨ Device Details



4.3 CrealityCloud printing



1. Scan the QR code and download the app



2. Download

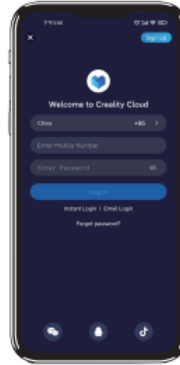

3. Sign up for an account

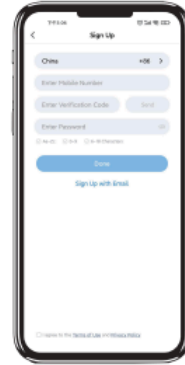

4. Log in



5. Add a new device



6. Add a device

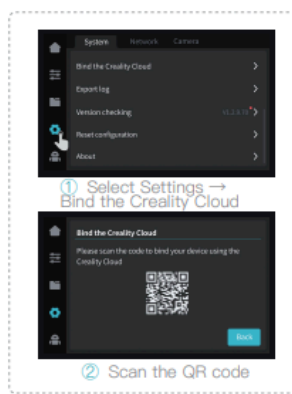

1 Select Settings → Bind the Creality Cloud

2 Scan the QR code

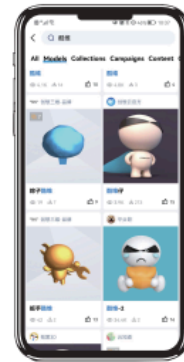

7. Select model on the homepage

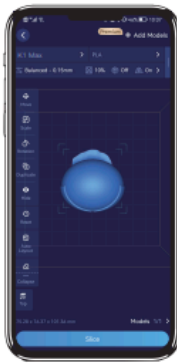

8. Slicing



9. Print

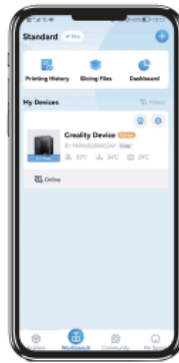

10. Select a device



11. Printing

5. K1 Max Functional Specification

5.1 Extrude、 Filament Retreat

Extrude

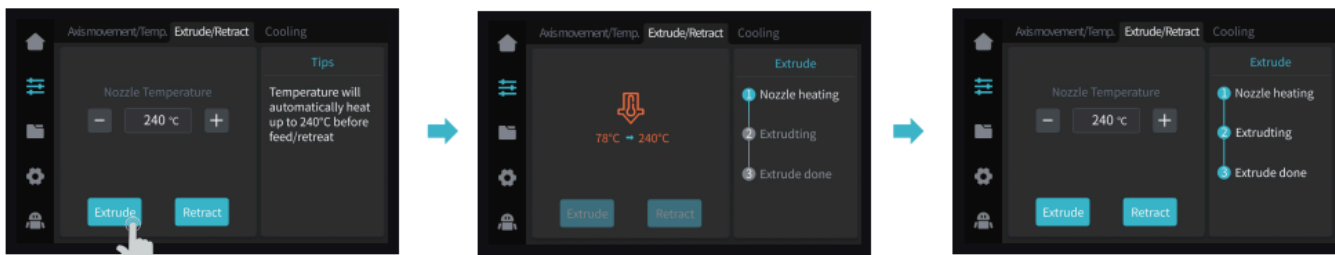

Filament Retreat

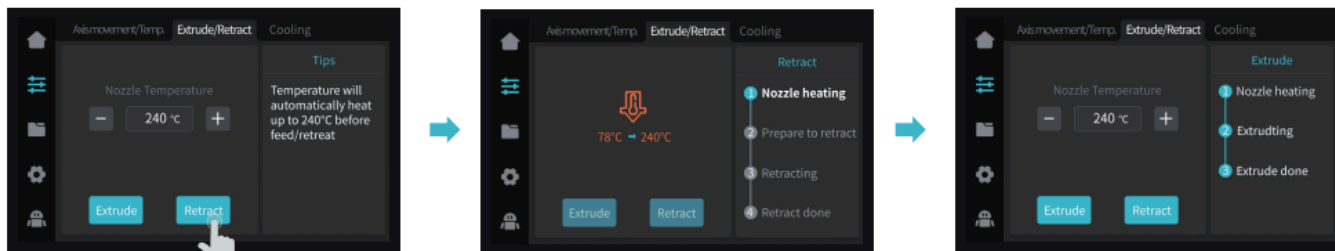

 Note: The current interface is for reference only. Due to the continuous upgrading of functions, it shall be subject to the latest firmware UI published on the official website.

5.2 Calibration

Select calibration, the machine will be leveled before printing the model and use AI LiDAR for first-layer detection.

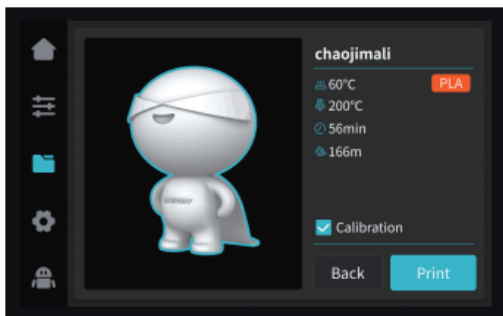

First-layer detection of printing:

Use AI Lidar and first-layer detection algorithm to check the first layer of the model to be printed, and report any first-layer quality problem found to the system, so as to prevent printing failure due to first-layer printing problems and to avoid wasting a lot of time and materials.

AI LiDAR :

- ① It's composed of laser and sensor. The laser is used to detect the surface of the measured object;
- ② The sensor is used to record the changes and generate point cloud data for the control system to call and process;
- ③ It's available to be applied to first-layer detection of printing.

5.3 AI function

1. When AI detection is turned on, the chamber camera will monitor the process of printing. If any defect is found during the printing, a window will pop up to remind you.
2. When you check the Push Pause Printing, the printing will pause if there is any printing defect.

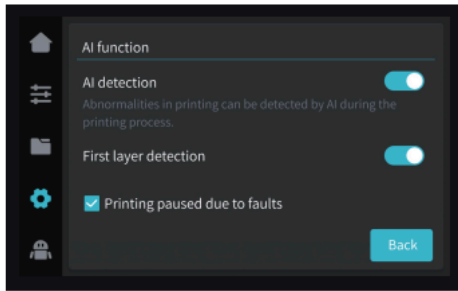

After printing starts, if there are foreign objects on the platform or the previous printed model is not removed, the printer will pause printing and give a reminder. (To avoiding damaging the extruder)
 After turning off the first-layer detection, the first-layer detection will not be performed during the calibration.
Note: Push pause printing if Any Fault is effective for both the AI detection and first-layer detection.

5.4 Self-inspection

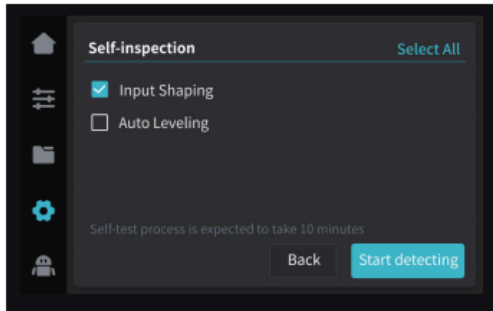

Input Shaping:

Ringings refer to the corrugated unevenness on the surface of the model that may be caused by the resonance of the machine or the action of external forces during the printing process. To solve this problem, the input shaping sensor is used to actively obtain the resonance frequency of the 3D printer, and algorithm is applied to correct this state to achieve the purpose of eliminating the model chatter marks. Using the input shaping can effectively suppress the machine vibration and improve the printing quality of the model to obtain a smooth model surface.

5.5 Network Settings

5.5.1 Wired connection

When the printer is connected to the network cable, you can click Settings → Local Network on the screen to check whether it is connected.

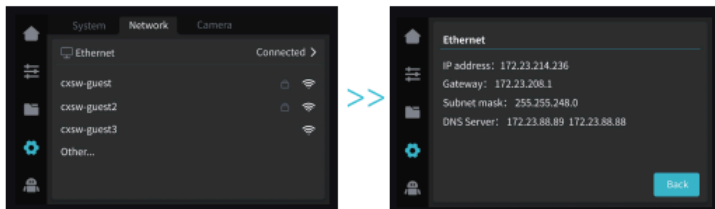

5.5.2 WIFI connection

Click Settings → Network → WIFI Connection on the screen, select the corresponding WIFI and enter the password to finish the WIFI connection. (only support 2.4 GHz).

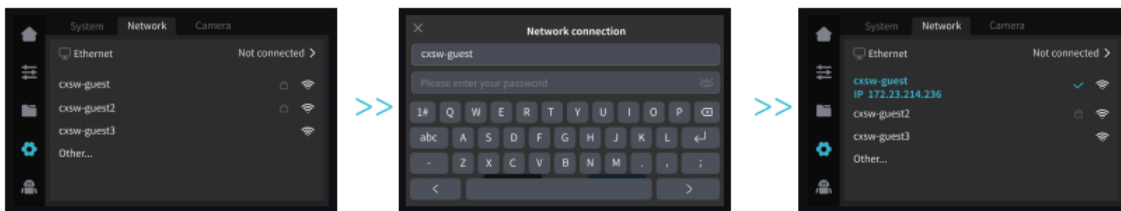

K1 Max/K1 Max2025 Maintenance

Routine Maintenance

1. Precautions for printing

1.1 Lubrication and maintenance

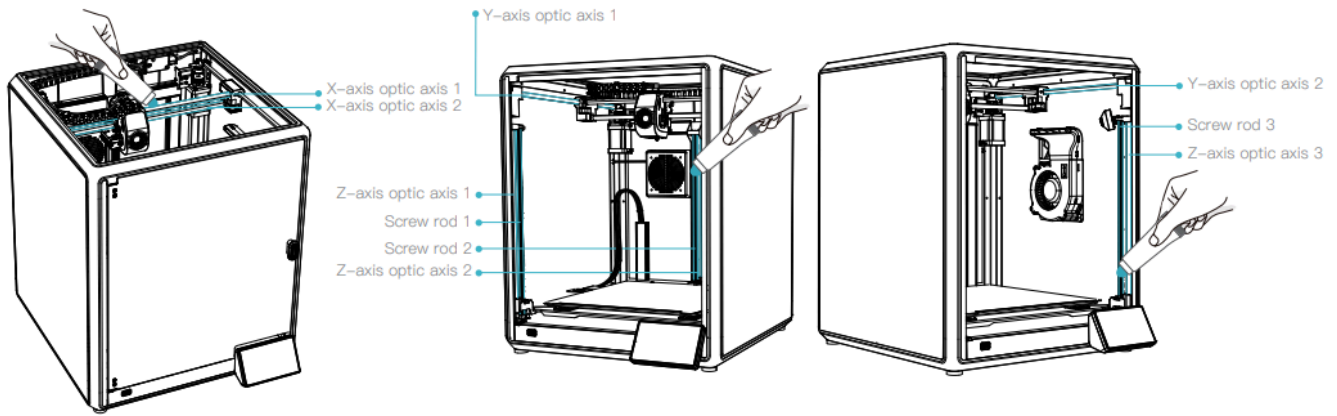

Regular maintenance for 300 hours: Please maintain the blue areas in Figure by greasing and lubricating them at regular intervals. Grease should only be applied to the middle part by dispensing and then applied automatically and evenly by movement.

1.2 Use and maintenance of flexible platform

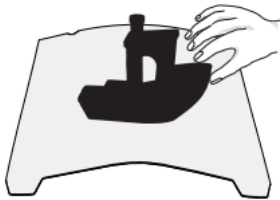

① Together with the flexible platform after the printed model has been cooled down Remove from the device and partially bend the platform slightly to separate the model from the platform.(No excessive bending of the platform to prevent it from being deformed and unusable)



② The residue of the platform filaments can be scraped off with a blade. Be cautious of safety when using.

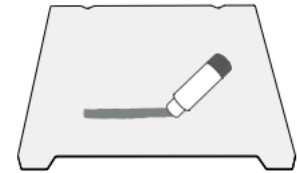

③ When the first layer of the model is not glued, it is recommended to apply glue stick evenly on the surface of the platform. The residual solid glue left after the printing can be cleaned with clean water.

6.1.3 Cleaning of debris inside the chassis

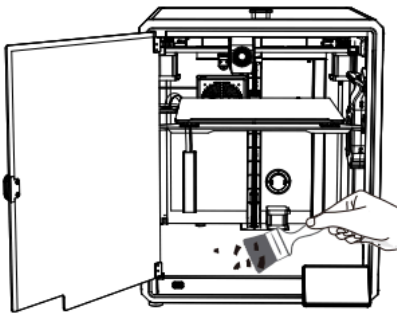

Reminder: When the printing time of the device exceeds 300 hours, or if the printing platform or nozzles have been replaced, the distance between the platform and nozzles may change that caused the first layer of the model may not stick firmly, resulting in printing failure. Please calibrate the platform regularly.



Reminder: Since the printing platform is quick-wear, it is recommended to replace the printing platform regularly to ensure that the first layer of the model is adhered.

In the event that any of the above problems arise and cannot be resolved:

- ① Please visit <https://www.crealitycloud.com/product> , click "Products" and select the right model, and then click "Related" to view the tutorials on after-sales service;
- ② Or contact our after-sales service center at +86 755 3396 5666, or send e-mail to cs@creality.com

2. Maintenance Items

	Maintenance instructions	
Machine cleanup	Clean the debris inside the machine to ensure that its operation is not affected.	Before each print
Hot end	Check if the wire output is normal, if not, please check if the extruder is blocked.	After each change of filaments
Printing platform	Check the surface of the platform for residual filaments and glue, if so, clean the surface of the platform.	Before each print
Motion mechanism	XYZ optic axis lubrication.	Cumulative print time per 500 hours
Air filtration	Replace the air filter cartridge.	Cumulative print time per 300 hours
Equipment self-test	Optimization of vibration veins.	Cumulative print time per 300 hours
	Auto Leveling.	
Filament replacement	Replacement of filaments of the same kind: follow the normal Retreat – Feed process.	/
	Replacement of different filaments: Preheat the nozzle to reach the target temperature of the current filament; then retreat it, replace with the target filament, and preheat the nozzle to the higher filament extrude temperature of the two filaments; feed for 30s until the filament has been completely extruded, and finally set the nozzle temperature to the temperature of current filament nozzle.	

3. Installation of Damping Pads

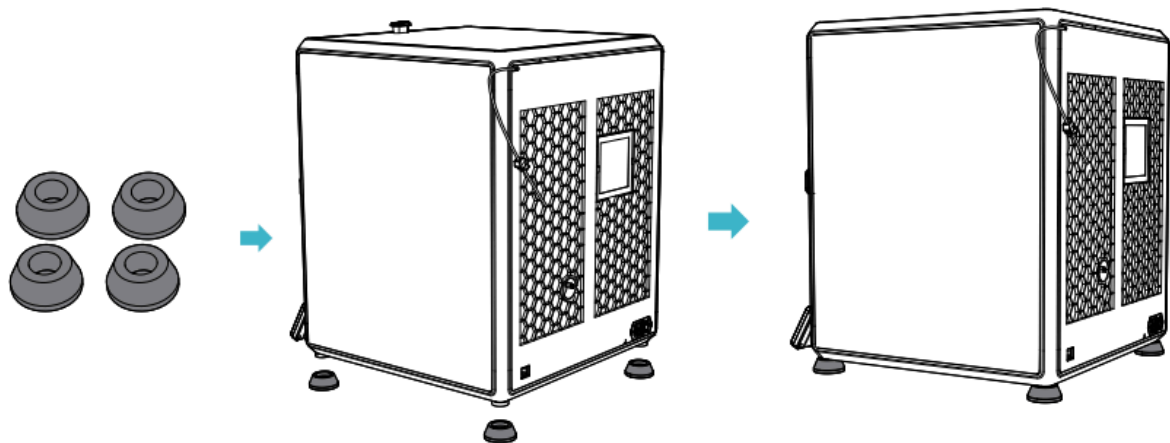

Since each model is different, the actual product may be different from the picture. Please refer to the actual product. The final interpretation right belongs to Shenzhen Creality 3D Technology Co., Ltd

Tips

If any of the problems arise and cannot be resolved, Please visit <https://www.crealitycloud.com/product> , click "Products" select the right model, and then click "Related" to view the tutorials on after-sales service;

Or directly contact our after-sales service center via online service channels (See [How to get Creality service](#) .

© 2026 Creality. All rights reserved. | Powered by [Wiki.js](#)