

Western Digital®



Product Manual

Ultrastar™ DC HC310

3.5-inch Serial ATA Hard Disk Drive

Models: HUS726T6TALE6L4
HUS726T6TALE6L1
HUS726T6TALE6L0
HUS726T4TALE6L4
HUS726T4TALE6L1
HUS726T4TALE6L0
HUS726T4TALA6L4
HUS726T4TALA6L1
HUS726T4TALA6L0
HUS726T2TALA6L4
HUS726T2TALA6L0

Revision 1.92
30 September 2025

Publication Disclaimer Information

Western Digital Technologies, Inc. or its affiliates' (collectively "Western Digital") general policy does not recommend the use of its products in life support applications where in a failure or malfunction of the product may directly threaten life or injury. Per Western Digital Terms and Conditions of Sale, the user of Western Digital products in life support applications assumes all risk of such use and indemnifies Western Digital against all damages. This document is for information use only and is subject to change without prior notice. Western Digital assumes no responsibility for any errors that may appear in this document, nor for incidental or consequential damages resulting from the furnishing, performance or use of this material.

Absent a written agreement signed by Western Digital or its authorized representative to the contrary, Western Digital explicitly disclaims any express and implied warranties and indemnities of any kind that may, or could, be associated with this document and related material, and any user of this document or related material agrees to such disclaimer as a precondition to receipt and usage hereof.

Each user of this document or any product referred to herein expressly waives all guaranties and warranties of any kind associated with this document any related materials or such product, whether expressed or implied, including without limitation, any implied warranty of merchantability or fitness for a particular purpose or non-infringement. Each user of this document or any product referred to herein also expressly agrees Western Digital shall not be liable for any incidental, punitive, indirect, special, or consequential damages, including without limitation physical injury or death, property damage, lost data, loss of profits or costs of procurement of substitute goods, technology, or services, arising out of or related to this document, any related materials or any product referred to herein, regardless of whether such damages are based on tort, warranty, contract, or any other legal theory, even if advised of the possibility of such damages.

This document and its contents, including diagrams, schematics, methodology, work product, and intellectual property rights described in, associated with, or implied by this document, are the sole and exclusive property of Western Digital. No intellectual property license, express or implied, is granted by Western Digital associated with the document recipient's receipt, access and/or use of this document or the products referred to herein; Western Digital retains all rights hereto.

This document and Western Digital communications to the user associated therewith, shall be treated as Western Digital's proprietary and confidential information, protected by the recipient as such, and used by the recipient only for the purpose authorized in writing by Western Digital. This document shall be covered as Western Digital's confidential information under all applicable nondisclosure agreements between the recipient and Western Digital. Western Digital, the Western Digital logo and Ultrastar are registered trademarks or trademarks of Western Digital Corporation or its affiliates in the US and/or other countries. All other marks are the property of their respective owners.

© 2019 Western Digital Corporation or its affiliates. All rights reserved.

References in this publication to Western Digital-branded products, programs, or services do not imply that they will be made available in all countries. Product specifications provided are sample specifications and do not constitute a warranty. Actual specifications for unique part numbers may vary. Please visit the Support section of our website, westerndigital.com/support, for additional information on product specifications. Pictures shown may vary from actual products.

Table of Contents

| | | |
|---------|--|----|
| 1 | General..... | 15 |
| 1.1 | Introduction | 15 |
| 1.2 | Glossary | 16 |
| 1.3 | General Caution | 16 |
| 1.4 | References | 16 |
| 2 | General Features..... | 17 |
| Part 1. | Functional Specification | 18 |
| 3 | Fixed Disk Subsystem Description | 19 |
| 3.1 | Control Electronics..... | 19 |
| 3.2 | Head Disk Assembly | 19 |
| 3.3 | Actuator | 19 |
| 4 | Drive Characteristics | 20 |
| 4.1 | Default Logical Drive Parameters..... | 20 |
| 4.2 | Data Sheet | 21 |
| 4.3 | World Wide Name Assignment..... | 21 |
| 4.4 | Drive Organization..... | 22 |
| 4.4.1 | Drive Format..... | 22 |
| 4.4.2 | Cylinder Allocation..... | 22 |
| 4.5 | Performance Characteristics | 23 |
| 4.5.1 | Mechanical Positioning..... | 23 |
| 4.5.2 | Drive Ready Time..... | 24 |
| 4.5.3 | Operating Modes..... | 24 |
| 5 | Defect Flagging Strategy | 26 |
| 5.1 | Shipped Format..... | 26 |
| 6 | Specification..... | 27 |
| 6.1 | Electrical Interface..... | 27 |
| 6.1.1 | Connector Location | 27 |
| 6.1.2 | Signal Definition (SATA)..... | 29 |
| 6.1.3 | Out-of-Band Signaling (SATA)..... | 30 |
| 6.1.4 | Voltage and Ground Signals | 30 |
| 6.1.5 | Ready LED Output | 30 |
| 6.2 | Environment..... | 31 |
| 6.2.1 | Temperature and Humidity..... | 31 |
| 6.2.2 | Storage Requirements..... | 32 |
| 6.2.3 | Corrosion Test | 32 |
| 6.2.4 | Atmospheric Condition | 33 |
| 6.3 | DC Power Requirements..... | 34 |
| 6.3.1 | Input Voltage..... | 34 |
| 6.3.2 | Power Supply Current | 36 |
| 6.3.3 | Power Line Noise Limits | 39 |
| 6.3.4 | Power Consumption Efficiency..... | 39 |
| 6.4 | Reliability..... | 40 |
| 6.4.1 | Data Integrity..... | 40 |
| 6.4.2 | Cable Noise Interference | 40 |
| 6.4.3 | Load/Unload | 40 |
| 6.4.4 | Start/Stop Cycles..... | 40 |
| 6.4.5 | Preventive Maintenance | 40 |
| 6.4.6 | Data Reliability | 40 |
| 6.5 | Mechanical Specifications | 41 |
| 6.5.1 | Physical Dimensions | 41 |
| 6.5.2 | Drive Mounting | 42 |

| | | |
|--------|--|----|
| 6.5.3 | Heads Unload and Actuator Lock | 42 |
| 6.6 | Vibration and Shock | 43 |
| 6.6.1 | Operating Vibration..... | 43 |
| 6.6.2 | Non-operating Vibration..... | 44 |
| 6.6.3 | Operating Shock..... | 44 |
| 6.6.4 | Non-operating Shock..... | 44 |
| 6.6.5 | Non-operating Rotational Shock | 45 |
| 6.7 | Acoustics | 46 |
| 6.8 | Identification Labels | 46 |
| 6.9 | Safety | 47 |
| 6.9.1 | UL and CSA Standard Conformity | 47 |
| 6.9.2 | European Safety Mark..... | 47 |
| 6.9.3 | Flammability..... | 47 |
| 6.9.4 | Safe Handling..... | 47 |
| 6.9.5 | Substance Restriction Requirements..... | 47 |
| 6.9.6 | Secondary Circuit Protection..... | 47 |
| 6.10 | Electromagnetic Compatibility | 48 |
| 6.10.1 | CE Mark..... | 48 |
| 6.10.2 | RCM Mark | 48 |
| 6.10.3 | BSMI Mark..... | 48 |
| 6.10.4 | KC Mark..... | 49 |
| 6.11 | Third-Party Notices | 49 |
| Part 2 | Interface Specification..... | 50 |
| 7 | General..... | 51 |
| 7.1 | Introduction | 51 |
| 7.2 | Terminology | 51 |
| 7.3 | Deviations From Standard | 51 |
| 8 | Registers | 52 |
| 8.1 | Alternate Status Register | 52 |
| 8.2 | Command Register | 52 |
| 8.3 | Cylinder High Register | 52 |
| 8.4 | Cylinder Low Register..... | 53 |
| 8.5 | Device Control Register | 53 |
| 8.6 | Device/Head Register | 53 |
| 8.7 | Error Register | 54 |
| 8.8 | Features Register | 54 |
| 8.9 | Sector Count Register | 54 |
| 8.10 | Sector Number Register | 54 |
| 8.11 | Status Register..... | 55 |
| 9 | General Operation Descriptions..... | 56 |
| 9.1 | Reset Response | 56 |
| 9.1.1 | Register Initialization | 57 |
| 9.2 | Diagnostic and Reset Considerations..... | 57 |
| 9.3 | Sector Addressing Mode..... | 58 |
| 9.3.1 | Logical CHS Addressing Mode | 58 |
| 9.3.2 | LBA Addressing Mode..... | 58 |
| 9.4 | Power Management Feature | 59 |
| 9.4.1 | Power Mode | 59 |
| 9.4.2 | Power Management Commands | 60 |
| 9.4.3 | Standby Timer..... | 60 |
| 9.4.4 | Interface Capability for Power Modes | 60 |
| 9.5 | SMART Function..... | 61 |
| 9.5.1 | Attributes..... | 61 |

| | | |
|--------|--|-----|
| 9.5.3 | Attribute Thresholds..... | 61 |
| 9.5.4 | Threshold Exceeded Condition..... | 61 |
| 9.5.5 | SMART Commands..... | 61 |
| 9.5.6 | Off-Line Read Scanning..... | 61 |
| 9.5.7 | Error Log | 62 |
| 9.5.8 | Self-Test..... | 62 |
| 9.6 | Security Mode Feature Set | 63 |
| 9.6.1 | Security Mode..... | 63 |
| 9.6.2 | Security Level..... | 63 |
| 9.6.3 | Password..... | 63 |
| 9.6.4 | Operation Example | 64 |
| 9.6.5 | Command Table | 67 |
| 9.7 | Host Protected Area Feature | 70 |
| 9.7.1 | Example for Operation (in LBA mode)..... | 70 |
| 9.7.2 | Security Extensions | 71 |
| 9.8 | Write Cache Function | 72 |
| 9.9 | Reassign Function | 72 |
| 9.9.1 | Auto Reassign Function..... | 72 |
| 9.10 | Power-Up in Standby Feature Set..... | 73 |
| 9.11 | Advanced Power Management Feature Set (APM) | 73 |
| 9.12 | 48-bit Address Feature Set..... | 73 |
| 9.13 | Streaming Feature Set | 74 |
| 9.13.1 | Streaming Commands | 74 |
| 9.14 | SATA BIST (built-in self-test) | 76 |
| 9.15 | SATA Interface Power Management..... | 77 |
| 9.15.1 | Low PHY Power Conditions Overview | 77 |
| 9.15.2 | Active PHY Power Condition..... | 77 |
| 9.15.3 | Partial PHY Power Condition | 77 |
| 9.15.4 | Slumber PHY Power Condition..... | 77 |
| 9.16 | Software Setting Preservation | 78 |
| 9.16.1 | COMRESET Preservation Requirements..... | 78 |
| 9.17 | Serial ATA Optional Features | 79 |
| 9.17.1 | Asynchronous Signal Recovery | 79 |
| 9.17.2 | Device Power Connector Pin 11 Definition..... | 79 |
| 9.17.3 | Phy Event Counters..... | 79 |
| 9.17.4 | NCQ NON-DATA (63h) | 84 |
| 9.17.5 | Rebuild Assist..... | 88 |
| 9.17.6 | Power Disable..... | 89 |
| 9.18 | SCT Command Transport Feature Set..... | 90 |
| 9.18.1 | Overview | 90 |
| 9.18.2 | SCT Command Protocol..... | 92 |
| 9.18.3 | SCT Command Set..... | 100 |
| 9.19 | Extended Power Conditions (EPC) Feature..... | 108 |
| 9.19.1 | Power Conditions | 108 |
| 9.19.2 | Power Condition Timers | 109 |
| 9.19.3 | Interaction with Resets, Commands and Other Features | 109 |
| 9.20 | Sanitize Device Feature Set | 110 |
| 9.20.1 | Overview | 110 |
| 9.20.2 | Sanitize Device Feature..... | 111 |
| 9.20.3 | Sanitize Device State Machine | 112 |
| 9.21 | Trusted Computing Group Feature Set..... | 114 |
| 9.21.1 | Referenced Specifications and Standards | 114 |
| 9.21.2 | Implementation Exceptions..... | 115 |
| 9.21.3 | Implementation Features and Details Outside of TCG Specifications..... | 115 |

| | | |
|---------|--|-----|
| 9.21.4 | Encryption Algorithms..... | 116 |
| 9.21.5 | TCG Enterprise SSC Tables | 117 |
| 9.21.6 | Firmware Download and Signing | 120 |
| 9.21.7 | Ports..... | 120 |
| 9.21.8 | MSID..... | 123 |
| 9.21.9 | Logging | 123 |
| 9.21.10 | Number of Sessions | 123 |
| 9.21.11 | Number of Bands..... | 123 |
| 9.21.12 | Number of COMIDs | 123 |
| 9.21.13 | PSID | 123 |
| 9.21.14 | Locked and Unlocked Behavior | 124 |
| 9.21.15 | Error Codes..... | 129 |
| 9.21.16 | Life Cycle Model | 129 |
| 9.21.17 | Customer Specific Requirements..... | 129 |
| 9.21.18 | Switching Between TCG Enterprise and ISE Model..... | 129 |
| 9.21.19 | Block SID Authentication..... | 130 |
| 10 | Command Protocol..... | 131 |
| 10.1 | PIO Data-In Commands..... | 131 |
| 10.2 | PIO Data-Out Commands | 131 |
| 10.3 | Non-Data Commands | 132 |
| 10.4 | DMA Data-In Commands and DMA Data-Out Commands | 133 |
| 10.5 | First-Party DMA Commands | 133 |
| 11 | Command Descriptions..... | 134 |
| 11.1 | Check Power Mode (E5h/98h)..... | 139 |
| 11.2 | Configure Stream (51h)..... | 140 |
| 11.3 | Device Configuration Overlay (B1h)..... | 142 |
| 11.3.1 | Device Configuration Restore (Subcommand C0h)..... | 143 |
| 11.3.2 | Device Configuration Freeze Lock (Subcommand C1h)..... | 143 |
| 11.3.3 | Device Configuration Identify (Subcommand C2h) | 143 |
| 11.3.4 | Device Configuration Set (Subcommand C3h) | 143 |
| 11.4 | Download Microcode (92h) | 146 |
| 11.5 | Download Microcode DMA (93h)..... | 148 |
| 11.6 | Execute Device Diagnostic (90h)..... | 150 |
| 11.7 | Flush Cache (E7h) | 151 |
| 11.8 | Flush Cache Ext (EAh)..... | 152 |
| 11.9 | Format Track (50h)..... | 153 |
| 11.10 | Format Unit (F7h) | 154 |
| 11.11 | Identify Device (ECh) | 155 |
| 11.12 | Idle (E3h/97h)..... | 166 |
| 11.13 | Idle Immediate (E1h/95h) | 167 |
| 11.14 | Initialize Device Parameters (91h) | 168 |
| 11.15 | NCQ NON-DATA (63h)..... | 169 |
| 11.15.1 | Abort NCQ Queue Subcommand (0h) | 170 |
| 11.15.2 | Deadline Handling Subcommand (1h) | 172 |
| 11.15.3 | Set Features Subcommand (5h)..... | 174 |
| 11.16 | RECEIVE FPDMA QUEUED (65h)..... | 176 |
| 11.16.1 | READ LOG DMA EXT (1h)..... | 177 |
| 11.17 | SEND FPDMA QUEUED (64h) | 179 |
| 11.17.1 | WRITE LOG DMA EXT (2h)..... | 180 |
| 11.18 | Read Buffer (E4h) | 182 |
| 11.19 | Read Buffer DMA (E9h)..... | 183 |
| 11.20 | Read DMA(C8h/C9h) | 184 |
| 11.21 | Read DMA Ext (25h)..... | 186 |
| 11.22 | Read FPDMA Queued (60h) | 188 |

| | | |
|----------|---|-----|
| 11.23 | Read Log Ext (2Fh) | 190 |
| 11.23.1 | General Purpose Log Directory | 192 |
| 11.23.2 | Extended Comprehensive SMART Error Log | 193 |
| 11.23.3 | Device Statistics Log | 196 |
| 11.23.4 | Extended Self-Test Log Sector | 202 |
| 11.23.5 | Power Conditions Log | 203 |
| 11.23.6 | Queued Error Log | 206 |
| 11.23.7 | Read Stream Error Log | 207 |
| 11.23.8 | Write Stream Error Log | 208 |
| 11.23.9 | Sector Configuration Log | 208 |
| 11.23.10 | Identify Device Data Log | 210 |
| 11.24 | Read Log DMA Ext (47h) | 222 |
| 11.25 | Read Multiple (C4h) | 223 |
| 11.26 | Read Multiple Ext (29h) | 224 |
| 11.27 | Read Native Max Address (F8h) | 226 |
| 11.28 | Read Native Max Address Ext (27h) | 227 |
| 11.29 | Read Sector(s) (20h/21h) | 228 |
| 11.30 | Read Sector(s) Ext (24h) | 229 |
| 11.31 | Read Stream DMA Ext(2Ah) | 230 |
| 11.32 | Read Stream Ext (2Bh) | 233 |
| 11.33 | Read Verify Sector(s) (40h/41h) | 236 |
| 11.34 | Read Verify Sector(s) Ext (42h) | 237 |
| 11.35 | Recalibrate (1xh) | 238 |
| 11.36 | Request Sense Data Ext (0Bh) | 239 |
| 11.37 | Sanitize Device Feature Set (B4h) | 241 |
| 11.37.1 | Crypto Scramble Ext Command (Feature: 0011h) | 241 |
| 11.37.2 | Overwrite Ext Command (Feature: 0014h) | 243 |
| 11.37.3 | Sanitize Freeze Lock Ext Command (Feature: 0020h) | 245 |
| 11.37.4 | Sanitize Status Ext Command (Feature: 0000h) | 247 |
| 11.38 | Security Disable Password (F6h) | 249 |
| 11.39 | Security Erase Prepare (F3h) | 250 |
| 11.40 | Security Erase Unit (F4h) | 251 |
| 11.41 | Security Freeze Lock (F5h) | 253 |
| 11.42 | Security Set Password (F1h) | 254 |
| 11.43 | Security Unlock (F2h) | 256 |
| 11.44 | Seek (7xh) | 257 |
| 11.45 | Sense Condition (F0h : Vendor-specific) | 258 |
| 11.46 | Set Features (EFh) | 259 |
| 11.46.1 | Set Transfer Mode | 260 |
| 11.46.2 | Write Cache | 260 |
| 11.46.3 | Serial ATA Feature | 260 |
| 11.46.4 | Advanced Power Management | 261 |
| 11.46.5 | Set Maximum Host Interface Sector Time | 261 |
| 11.46.6 | Extended Power Conditions (EPC) Feature | 262 |
| 11.47 | Set Max Address (F9h) | 269 |
| 11.47.1 | Set Max Set Password (Feature = 01h) | 271 |
| 11.47.2 | Set Max Lock (Feature = 02h) | 272 |
| 11.47.3 | Set Max Unlock (Feature = 03h) | 273 |
| 11.47.4 | Set Max Freeze Lock (Feature = 04h) | 274 |
| 11.48 | Set Max Address Ext (37h) | 275 |
| 11.49 | Set Multiple (C6h) | 277 |
| 11.50 | Set Sector Configuration Ext (B2h) | 278 |
| 11.51 | Sleep (E6h/99h) | 279 |
| 11.52 | SMART Function Set (B0h) | 280 |

| | | |
|---------|---|-----|
| 11.52.1 | SMART Subcommand | 281 |
| 11.52.2 | Device Attributes Data Structure..... | 285 |
| 11.52.3 | Device Attribute Thresholds Data Structure..... | 290 |
| 11.52.4 | SMART Log Directory | 291 |
| 11.52.5 | SMART Summary Error Log Sector | 291 |
| 11.52.6 | Self-Test Log Data Structure | 293 |
| 11.52.7 | Selective Self-Test Log Data Structure | 294 |
| 11.52.8 | Error Reporting | 295 |
| 11.53 | Standby (E2h/96h) | 296 |
| 11.54 | Standby Immediate (E0h/94h) | 297 |
| 11.55 | Trusted Receive (5Ch)..... | 298 |
| 11.56 | Trusted Receive DMA (5Dh)..... | 299 |
| 11.57 | Trusted Send (5Eh)..... | 300 |
| 11.58 | Trusted Send DMA (5Fh)..... | 301 |
| 11.59 | Write Buffer (E8h) | 302 |
| 11.60 | Write Buffer DMA (EBh)..... | 303 |
| 11.61 | Write DMA (CAh/CBh) | 304 |
| 11.62 | Write DMA FUA Ext (3Dh) | 305 |
| 11.63 | Write DMA Ext (35h)..... | 307 |
| 11.64 | Write FPDMA Queued (61h) | 309 |
| 11.65 | Write Log Ext (3Fh)..... | 311 |
| 11.66 | Write Log DMA Ext (57h)..... | 312 |
| 11.67 | Write Multiple (C5h)..... | 313 |
| 11.68 | Write Multiple Ext (39h) | 314 |
| 11.69 | Write Multiple FUA Ext (CEh)..... | 315 |
| 11.70 | Write Sector(s) (30h/31h)..... | 317 |
| 11.71 | Write Sector(s) Ext (34h)..... | 318 |
| 11.72 | Write Stream DMA Ext (3Ah) | 319 |
| 11.73 | Write Stream Ext (3Bh)..... | 322 |
| 11.74 | Write Uncorrectable Ext (45h)..... | 325 |

List of Tables

| | | |
|----------|---|----|
| Table 1 | R/N and Model #..... | 15 |
| Table 2 | Formatted Capacity..... | 20 |
| Table 3 | Data Sheet | 21 |
| Table 4 | World Wide Name Assignment..... | 21 |
| Table 5 | Average Seek Time | 23 |
| Table 6 | Single Track Seek Time..... | 23 |
| Table 7 | Latency Time | 23 |
| Table 8 | Drive Ready Time..... | 24 |
| Table 9 | 6TB Mode Transition Times..... | 25 |
| Table 10 | 4TB Mode Transition Times | 25 |
| Table 11 | Interface Connector Pins and I/O Signals..... | 29 |
| Table 12 | Parameter Descriptions | 30 |
| Table 13 | Temperature and Humidity..... | 31 |
| Table 14 | Input Voltage..... | 34 |
| Table 15 | SATA Power Consumption, 6TB, 4k..... | 36 |
| Table 16 | SATA Power Consumption, 4TB, 4k..... | 37 |
| Table 17 | SATA Power Consumption, 4TB, 512n..... | 38 |
| Table 18 | Allowable Power Supply Noise Limits at Drive Power Connector..... | 39 |
| Table 19 | Power Consumption Efficiency..... | 39 |
| Table 20 | Physical Dimensions | 41 |
| Table 21 | Random Vibration PSD Profile Break Points (operating)..... | 43 |
| Table 22 | Random Vibration (Rotational) PSD Profile Break Points | 43 |
| Table 23 | Random Vibration PSD Profile Break Points (Non-operating) | 44 |
| Table 24 | Sinusoidal Shock Wave | 45 |
| Table 25 | Rotational Shock | 45 |
| Table 26 | Sound Power Levels | 46 |
| Table 27 | Alternate Status Register | 52 |
| Table 28 | Device Control Register | 53 |
| Table 29 | Device/Head Register | 53 |
| Table 30 | Error Register..... | 54 |
| Table 31 | Status Register | 55 |
| Table 32 | Reset Response | 56 |
| Table 33 | Default Register Values | 57 |
| Table 34 | Diagnostic Codes..... | 57 |
| Table 35 | Power Conditions..... | 60 |
| Table 36 | Command Table for Device Lock Operation -1..... | 67 |
| Table 37 | Command Table for Device Lock Operation -2..... | 68 |
| Table 38 | Command Table for Device Lock Operation -3..... | 69 |
| Table 39 | Phy Event Counter Identifiers | 80 |
| Table 40 | READ LOG EXT Log Page 11h Data Structure Definition | 83 |
| Table 41 | NCQ NON-DATA - Command Definition..... | 84 |
| Table 42 | Subcommand Field..... | 84 |
| Table 43 | NCQ NON-DATA Log (12h) Data Structure Definition..... | 86 |
| Table 44 | Rebuild Assist Log (15h) Data Structure Definition | 88 |
| Table 45 | SCT Log Page and Direction..... | 90 |
| Table 46 | Identify Device Information Word 206..... | 90 |
| Table 47 | Output Registers of SCT Command Using SMART | 92 |
| Table 48 | Input Registers of SCT Command Using SMART | 92 |
| Table 49 | Input Registers of SCT Command Using Write Log Ext | 93 |
| Table 50 | Output Registers of SCT Command Using Write Log Ext..... | 93 |
| Table 51 | Key Sector Format..... | 94 |

| | | |
|-----------|---|-----|
| Table 52 | SCT Action Code List | 94 |
| Table 53 | Extended Status Code | 95 |
| Table 54 | Input Registers of SCT Data Transfer Using SMART | 96 |
| Table 55 | Input Registers of SCT Data Transfer using Read/Write Log Ext | 96 |
| Table 56 | Input Registers of SCT Status Request Using SMART | 97 |
| Table 57 | Input Registers of SCT Status Request Using Read Log Ext | 97 |
| Table 58 | Data Format of SCT Status Response -1 | 98 |
| Table 59 | Data Format of SCT Status Response -2 | 99 |
| Table 60 | SCT Write Same (Inputs) | 100 |
| Table 61 | Output Registers of SCT Write Same (Success) | 100 |
| Table 62 | Output Registers of SCT Write Same (Error) | 101 |
| Table 63 | Error Recovery Control Command (Inputs) | 102 |
| Table 64 | Error Recovery Control Command (On puts) | 102 |
| Table 65 | Feature Control Command (Inputs) | 103 |
| Table 66 | Feature Control Command (Outputs) | 103 |
| Table 67 | Feature Code List | 104 |
| Table 68 | SCT Data Table Command (Inputs) | 105 |
| Table 69 | SCT Data Table Command (Outputs) | 105 |
| Table 70 | Table ID and Descriptions | 105 |
| Table 71 | Data Format of HDA Absolute Temperature History Table -1 | 106 |
| Table 72 | Data Format of HDA Absolute Temperature History Table -2 | 107 |
| Table 73 | Extended Power Conditions Subcommands | 108 |
| Table 74 | Power Condition IDs | 108 |
| Table 75 | Vendor Specific Data for Level 0 Discovery | 116 |
| Table 76 | WDC Default Values for 'Admin SP' C_PIN & 'Locking SP' C_PIN | 117 |
| Table 77 | WDC Implementation of K_AES_256 Table | 118 |
| Table 78 | WDC Implementation of 'Locking SP' Access Control Table | 118 |
| Table 79 | WDC Implementation of 'Locking Info' Table | 119 |
| Table 80 | WDC Implementation of 'Locking SP' Locking Table | 119 |
| Table 81 | Ports Functionality | 120 |
| Table 82 | Ports Table | 120 |
| Table 83 | Modified 'Admin SP' ACE Table | 121 |
| Table 84 | Modified 'Admin SP' Access Control Table (part 1 of 2) | 121 |
| Table 85 | Modified 'Admin SP' Access Control Table (part 2 of 2) | 122 |
| Table 86 | Command table for TCG Enterprise Device Lock Operation -1 | 124 |
| Table 87 | Command Table for TCG Enterprise Device Lock Operation -2 | 125 |
| Table 88 | Command table for TCG Enterprise Device Lock Operation -3 | 126 |
| Table 89 | TCG Enterprise SSC Commands Behavior -1 | 127 |
| Table 90 | TCG Enterprise SSC Commands Behavior -2 | 127 |
| Table 91 | TCG Enterprise SSC Commands Behavior -3 | 127 |
| Table 92 | TCG Enterprise SSC Commands Behavior -4 | 128 |
| Table 93 | TCG Enterprise SSC Commands Behavior -5 | 128 |
| Table 94 | TCG Enterprise SSC Commands Behavior -6 | 128 |
| Table 95 | Command Set | 134 |
| Table 96 | Command Set –Continued | 135 |
| Table 97 | Command Set –Continued | 136 |
| Table 98 | Command Set (Subcommand) | 137 |
| Table 99 | Check Power Mode Command (E5h/98h) | 139 |
| Table 100 | Configure Stream Command (51h) | 140 |
| Table 101 | Device Configuration Overlay Command (B1h) | 142 |
| Table 102 | Device Configuration Overlay Features Register Values | 142 |
| Table 103 | Device Configuration Overlay Data Structure | 144 |
| Table 104 | DCO Error Information Definition | 145 |
| Table 105 | Download Microcode Command (92h) | 146 |

| | | |
|-----------|---|-----|
| Table 106 | Download Microcode DMA Command (93h) | 148 |
| Table 107 | Execute Device Diagnostic Command (90h) | 150 |
| Table 108 | Flush Cache Command (E7h) | 151 |
| Table 109 | Flush Cache Ext Command (EAh) | 152 |
| Table 110 | Format Track Command (50h) | 153 |
| Table 111 | Format Unit Command (F7h) | 154 |
| Table 112 | Identify Device Command (ECh) | 155 |
| Table 113 | Identify Device Information | 156 |
| Table 114 | Identify Device Information -Continued | 157 |
| Table 115 | Identify Device Information -Continued | 158 |
| Table 116 | Identify Device Information -Continued | 159 |
| Table 117 | Identify Device Information -Continued | 160 |
| Table 118 | Identify Device Information -Continued | 161 |
| Table 119 | Identify Device Information -Continued | 162 |
| Table 120 | Identify Device Information -Continued | 163 |
| Table 121 | Identify Device Information -Continued | 164 |
| Table 122 | Identify Device Information -Continued | 165 |
| Table 123 | Idle Command (E3h/97h) | 166 |
| Table 124 | Idle Immediate Command (E1h/95h) | 167 |
| Table 125 | Initialize Device Parameters Command (91h) | 168 |
| Table 126 | NCQ NON-DATA Command (63h) | 169 |
| Table 127 | Abort NCQ Queue Subcommand (0h) | 170 |
| Table 128 | Abort Type Field | 171 |
| Table 129 | Deadline handling Subcommand (1h) | 172 |
| Table 130 | SET FEATURES Subcommand (5h) | 174 |
| Table 131 | RECEIVE FPDMA QUEUED Command (65h) | 176 |
| Table 132 | RECEIVE FPDMA QUEUED Subcommand Field | 176 |
| Table 133 | READ LOG DMA EXT Subcommand (1h) | 177 |
| Table 134 | SEND FPDMA QUEUED command (64h) | 179 |
| Table 135 | SEND FPDMA QUEUED Subcommand Field | 179 |
| Table 136 | WRITE LOG DMA EXT Subcommand (2h) | 180 |
| Table 137 | Read Buffer Command (E4h) | 182 |
| Table 138 | Read Buffer DMA Command (E9h) | 183 |
| Table 139 | Read DMA Command (C8h/C9h) | 184 |
| Table 140 | Read DMA Ext Command (25h) | 186 |
| Table 141 | Read FPDMA Queued Command (60h) | 188 |
| Table 142 | Read Log Ext Command (2Fh) | 190 |
| Table 143 | Log Address Definition | 191 |
| Table 144 | Log Address Definition for Serial ATA | 191 |
| Table 145 | General Purpose Log Directory | 192 |
| Table 146 | General Purpose Log Directory for Serial ATA | 192 |
| Table 147 | Extended Comprehensive SMART Error Log | 193 |
| Table 148 | Extended Error Log Data Structure | 193 |
| Table 149 | Command Data Structure | 194 |
| Table 150 | Error Data Structure | 194 |
| Table 151 | Defined Device Statistics Log Pages | 196 |
| Table 152 | List of Supported Device Statistics Log Pages | 196 |
| Table 153 | General Statistics | 197 |
| Table 154 | Rotating Media Statistics | 198 |
| Table 155 | General Error Statistics | 199 |
| Table 156 | Temperature Statistics (Part 1 of 2) | 199 |
| Table 157 | Temperature Statistics (Part 2 of 2) | 200 |
| Table 158 | Transport Statistics | 201 |
| Table 159 | Extended Self-Test Log Data Structure | 202 |

| | | |
|-----------|---|-----|
| Table 160 | Extended Self-Test Log Descriptor Entry | 202 |
| Table 161 | Idle Power Conditions (log page 00h)..... | 203 |
| Table 162 | Standby Power Conditions (log page 01h) | 203 |
| Table 163 | Power Condition Log Description..... | 204 |
| Table 164 | Power Condition Log Description - Continued | 205 |
| Table 165 | Queued Error Log Data Structure Definition..... | 206 |
| Table 166 | Read Stream Error Log..... | 207 |
| Table 167 | Stream Error Log Entry..... | 207 |
| Table 168 | Write Stream Error Log..... | 208 |
| Table 169 | Sector Configuration Log | 208 |
| Table 170 | Sector Configuration Descriptor..... | 209 |
| Table 171 | Identify Device Data Log | 210 |
| Table 172 | List of Supported IDENTIFY DEVICE Data Pages..... | 210 |
| Table 173 | Capacity Log Page | 211 |
| Table 174 | Supported Capabilities Log Page | 212 |
| Table 175 | Supported Capabilities Log Page - Continued..... | 213 |
| Table 176 | Supported Capabilities Log Page - Continued..... | 214 |
| Table 177 | Current Settings Log Page | 215 |
| Table 178 | Current Settings Log Page - Continued..... | 216 |
| Table 179 | Strings Log Page..... | 216 |
| Table 180 | Security Log Page..... | 218 |
| Table 181 | Serial ATA Log Page | 219 |
| Table 182 | Serial ATA Log Page - Continued | 220 |
| Table 183 | Serial ATA Log Page - Continued | 221 |
| Table 184 | Read Log DMA Ext Command (47h) | 222 |
| Table 185 | Read Multiple Commands (C4h) | 223 |
| Table 186 | Read Multiple Ext Command (29h)..... | 224 |
| Table 187 | Read Native Max ADDRESS (F8h) | 226 |
| Table 188 | Read Native Max Address Ext (27h) | 227 |
| Table 189 | Read Sector(s) Command (20h/21h)..... | 228 |
| Table 190 | Read Sector(s) Ext Command (24h) | 229 |
| Table 191 | Read Stream DMA Ext Command (2Ah) | 230 |
| Table 192 | Read Stream Ext Command (2Bh)..... | 233 |
| Table 193 | Read Verify Sector(s) Command (40h/41h) | 236 |
| Table 194 | Read Verify Sector(s) Ext Command (42h)..... | 237 |
| Table 195 | Recalibrate Command (1xh) | 238 |
| Table 196 | Request Sense Data Ext command (0Bh) | 239 |
| Table 197 | Sanitize Device Feature Set (B4h) | 240 |
| Table 198 | Crypto Scramble Ext Command (B4h/0011h)..... | 241 |
| Table 199 | Overwrite Ext Command (B4h/0014h)..... | 243 |
| Table 200 | Sanitize Freeze Lock Ext Command (B4h/0020h)..... | 245 |
| Table 201 | Sanitize Status Ext Command (B4h/0000h) | 247 |
| Table 202 | Security Disable Password Command (F6h) | 249 |
| Table 203 | Password Information for Security Disable Password Command..... | 249 |
| Table 204 | Security Erase Prepare Command (F3h) | 250 |
| Table 205 | Security Erase Unit Command (F4h)..... | 251 |
| Table 206 | Erase Unit Information..... | 251 |
| Table 207 | Security Freeze Lock Command (F5h)..... | 253 |
| Table 208 | Security Set Password Command (F1h) | 254 |
| Table 209 | Security Set Password Information | 254 |
| Table 210 | Security Unlock Command (F2h) | 256 |
| Table 211 | Security Unlock Information | 256 |
| Table 212 | Seek Command (7xh) | 257 |
| Table 213 | Sense Condition Command (F0h)..... | 258 |

| | | |
|-----------|--|-----|
| Table 214 | Set Features Command (EFh)..... | 259 |
| Table 215 | Restore Power Condition Settings Subcommand..... | 262 |
| Table 216 | Go To Power Condition Subcommand..... | 263 |
| Table 217 | Set Power Condition Timer Subcommand..... | 264 |
| Table 218 | Set Power Condition State Subcommand..... | 266 |
| Table 219 | Enable the EPC Feature Subcommand..... | 267 |
| Table 220 | Disable the EPC feature subcommand..... | 268 |
| Table 221 | Set Max ADDRESS (F9h)..... | 269 |
| Table 222 | Set Max Set Password..... | 271 |
| Table 223 | Set Max Set Password data contents..... | 271 |
| Table 224 | Set Max Lock..... | 272 |
| Table 225 | Set Max Unlock (F9h)..... | 273 |
| Table 226 | Set Max Freeze Lock (F9h)..... | 274 |
| Table 227 | Set Max Address Ext Command (37h)..... | 275 |
| Table 228 | Set Multiple Commands (C6h)..... | 277 |
| Table 229 | Set Sector Configuration Ext Commands (B2h)..... | 278 |
| Table 230 | Sleep Command (E6h/99h)..... | 279 |
| Table 231 | SMART Function Set Command (B0h)..... | 280 |
| Table 232 | Log Sector Addresses..... | 283 |
| Table 233 | Device Attribute Data Structure..... | 285 |
| Table 234 | Individual Attribute Data Structure..... | 286 |
| Table 235 | Device Attribute Thresholds Data Structure..... | 290 |
| Table 236 | Individual Threshold Data Structure..... | 290 |
| Table 237 | SMART Log Directory..... | 291 |
| Table 238 | SMART Summary Error Log Sector..... | 291 |
| Table 239 | Error Log Data Structure..... | 292 |
| Table 240 | Command Data Structure..... | 292 |
| Table 241 | Error Data Structure..... | 292 |
| Table 242 | Self-Test Log Data Structure..... | 293 |
| Table 243 | Selective Self-Test Log Data Structure..... | 294 |
| Table 244 | Selective Self-Test Feature Flags..... | 294 |
| Table 245 | SMART Error Codes..... | 295 |
| Table 246 | Standby Command (E2h/96h)..... | 296 |
| Table 247 | Standby Immediate Command (E0h/94h)..... | 297 |
| Table 248 | Trusted Receive Command (5Ch)..... | 298 |
| Table 249 | Trusted Receive DMA Command (5Dh)..... | 299 |
| Table 250 | Trusted Send Command (5Eh)..... | 300 |
| Table 251 | Trusted Send DMA Command (5Fh)..... | 301 |
| Table 252 | Write Buffer Command (E8h)..... | 302 |
| Table 253 | Write Buffer DMA Command (EBh)..... | 303 |
| Table 254 | Write DMA Command (CAh/CBh)..... | 304 |
| Table 255 | Write DMA FUA Ext Command (3Dh)..... | 305 |
| Table 256 | Write DMA Ext Command (35h)..... | 307 |
| Table 257 | Write FPDMA Queued Command (61h)..... | 309 |
| Table 258 | Write Log Ext Command (3Fh)..... | 311 |
| Table 259 | Write Log DMA Ext Command (57h)..... | 312 |
| Table 260 | Write Multiple Command (C5h)..... | 313 |
| Table 261 | Write Multiple Ext Command (39h)..... | 314 |
| Table 262 | Write Multiple FUA Ext Command (CEh)..... | 315 |
| Table 263 | Write Sector(s) Command (30h/31h)..... | 317 |
| Table 264 | Write Sector(s) Ext Command (34h)..... | 318 |
| Table 265 | Write Stream DMA Ext Command (3Ah)..... | 319 |
| Table 266 | Write Stream Ext Command (3Bh)..... | 322 |
| Table 267 | Write Uncorrectable Ext Command (45h)..... | 325 |

List of Figures

| | | |
|-----------|---|-----|
| Figure 1 | PList Physical Format | 26 |
| Figure 2 | Connector Location..... | 27 |
| Figure 3 | Connector Pin Assignments | 27 |
| Figure 4 | The Timing of COMRESET, COMINIT and COMWAKE..... | 30 |
| Figure 5 | Limits of Temperature and Altitude..... | 31 |
| Figure 6 | Limits of Temperature and Humidity | 32 |
| Figure 7 | Start-up Current Waveforms..... | 34 |
| Figure 8 | Idle_C Standby_Y Recovery Current Waveform | 35 |
| Figure 9 | Standby_Z Recovery Current Waveform | 35 |
| Figure 10 | Top, Bottom, Side Views and Mechanical Dimensions, with Connector Position (SATA) | 41 |
| Figure 11 | Initial Setting..... | 64 |
| Figure 12 | Usual Operation | 65 |
| Figure 13 | Password Lost..... | 66 |
| Figure 14 | Sanitize Device State Machines | 112 |

1 General

1.1 Introduction

This document describes the specifications of the Western Digital Ultrastar DC HC310 3.5-inch 7200-rpm serial ATA interface hard disk drive with the following model numbers:

| Capacity | R/N | Interface | Format | Model# | Security | Pin3 Power Control |
|----------|-----------|-----------|-----------------------|-----------------|-------------------------|--------------------|
| 6TB | US7SAN6T0 | SATA | 3.5" SATA 6Gb 512e | HUS726T6TALE6L4 | Base (SE) | Not supported |
| | | | 3.5" SATA 6Gb 512e | HUS726T6TALE6L1 | SED | Not supported |
| | | | 3.5" SATA 6Gb 512e | HUS726T6TALE6L0 | Instant Secure Erase | Not supported |
| 4TB | US7SAN4T0 | SATA | 3.5" SATA 6Gb 512e | HUS726T4TALE6L4 | Base (SE) | Not supported |
| | | | 3.5" SATA 6Gb 512e | HUS726T4TALE6L1 | SED | Not supported |
| | | | 3.5" SATA 6Gb 512e | HUS726T4TALE6L0 | Instant Secure Erase | Not supported |
| | | | 3.5" SATA 6Gb 512n | HUS726T4TALA6L4 | Base (SE) | Not supported |
| | | | 3.5" SATA 6Gb 512n | HUS726T4TALA6L1 | SED | Not supported |
| | | | 3.5" SATA 6Gb 512n | HUS726T4TALA6L0 | Instant Secure Erase | Not supported |
| 2TB | US7SAN4T0 | SATA | 3.5" SATA 6Gb 512n | HUS726T2TALA6L4 | Base (SE) | Not supported |
| | | | 3.5" SATA 6Gb 512n | HUS726T2TALA6L0 | Instant Secure Erase | Not supported |

Table 1 R/N and Model #

How to Read Model Numbers

HUS726T6TALE6L4 - 6TB SATA 6Gb/s 512e Base (SE) with Legacy Pin 3 Config

H = Western Digital

U = Ultrastar

S = Standard

72 = 7200 RPM

6T = Max capacity in series (6TB)

6T = Capacity of this model (6TB)

L = 26.1mm z-height

E6 = Interface (512e SATA 6Gb/s)

(52 = 512e SAS 12Gb/s)

** 512e models can be converted to 4Kn format and vice versa

y = Power Disable Pin 3 status

(0 = Power Disable Pin 3 support
L = Legacy Pin 3 config – No Power Disable Support)
z = Data Security Mode
0 = Instant Secure Erase
1 = SED*: Self Encrypting Drive
TCG-Enterprise and Sanitize Crypto Scramble / Erase
4 = Base (SE)*: No Encryption, Sanitize Overwrite only

* ATA Security Feature Set comes standard on SATA

** See section **11.5 Section Set Sector Configuration Ext**

1.2 Glossary

| | |
|------------|---|
| ADM | Automatic Drive Maintenance |
| BDE | Bulk Data Encryption |
| DFT | Drive Fitness Test |
| ESD | Electrostatic Discharge |
| FIPS | Federal Information Processing Standards |
| GB | 1,000,000,000 bytes |
| Gbps | 1,000,000,000 bits per second |
| ISE | Instant Secure Erase |
| kB | 1,024 bytes |
| kbpi | 1,000 bits per inch |
| ktpi | 1,000 tracks per inch |
| MB | 1,000,000 bytes |
| MB/s | 1,000,000 bytes per second |
| Mbps | 1,000,000 bits per second |
| MiB | 1,048,576 bytes |
| MiB/s | 1,048,576 bytes per second |
| PI | Protection Information |
| PSID | Physical Presence Security ID |
| SE | Secure Erase |
| SED | Self-Encrypting Drive |
| S.M.A.R.T. | Self-Monitoring Analysis and Reporting Technology |
| TB | 1,000,000,000,000 bytes |
| TCG | Trusted Computing Group |

1.3 General Caution

Do not apply force to the top cover. Handle the drive by its edges or frame only.

Do not touch the interface connector pins or the surface of the printed circuit board.

The drive can be damaged by shock or ESD (Electrostatic Discharge). Any damage sustained by the drive after removal from the shipping package and opening the ESD protective bag are the responsibility of the user.

1.4 References

- Serial ATA II: Extensions to Serial ATA 1.0
- Serial ATA International Organization: Serial ATA Revision 3.2
- Serial ATA International Organization: Serial ATA Revision 3.2 TPR056r13 Enable new Power Disable feature on standard SATA connector P3
- Serial ATA International Organization: Serial ATA Revision 3.2 ECN079v2 TPR056 Corrections for Power Disable

2 General Features

- Data capacities of 4TB, 6TB
 - Spindle speed 7200 RPM
 - Fluid dynamic bearing motor
 - Dual stage actuator
 - Closed-loop actuator servo
 - Load/unload mechanism, non-head disk contact start/stop
 - Automatic actuator lock
 - Write cache
 - Power saving modes/low RPM idle mode (APM)
 - S.M.A.R.T. (Self-Monitoring and Analysis Reporting Technology)
 - Adaptive zone formatting
 - RVS (Rotational Vibration Safeguard)
 - Sector buffer size of 256MiB
 - Seek time of 8.0ms in read operation (without command overhead)
 - Segmented buffer implementation
 - Automatic error recovery procedures for read and write commands
 - Automatic defect reallocation
 - Power Disable
 - PSID Support
-
- Sector format of 512 bytes/sector, 4096 bytes/sector
 - Native command queuing support
 - Self-diagnostics
 - Serial ATA data transfer 6/3Gbps
 - CHS and LBA modes
 - Security feature support
 - 48 bit addressing feature
 - SATA 3.2 compliant with optional SATA 3.3 Power Disable Feature support
 - Full disk encryption support (specific models only)

Part 1. Functional Specification

3 Fixed Disk Subsystem Description

3.1 Control Electronics

The drive is electronically controlled by a microprocessor, several logic modules, digital/analog modules, and various drivers and receivers. The control electronics perform the following major functions:

- Controls and interprets all interface signals between the host controller and the drive.
- Controls read write accessing of the disk media, including defect management and error recovery.
- Controls starting, stopping, and monitoring of the spindle.
- Conducts a power-up sequence and calibrates the servo.
- Analyzes servo signals to provide closed loop control. These include position error signal and estimated velocity.
- Monitors the actuator position and determines the target track for a seek operation.
- Controls the voice coil motor and secondary actuator drivers to align the actuator in a desired position.
- Constantly monitors error conditions of the servo and takes corresponding action if an error occurs.
- Monitors various timers such as head settle and servo failure.
- Performs self-checkout (diagnostics).

3.2 Head Disk Assembly

The head disk assembly (HDA) is assembled in a clean room environment and contains the disks, a spindle motor, actuator assembly, and voice coil motor. Air is constantly circulated and filtered when the drive is operational. Venting of the HDA is accomplished via a breather filter.

The spindle is driven directly by a brushless, sensor-less DC drive motor. Dynamic braking is used to stop the spindle quickly.

3.3 Actuator

The read/write heads are mounted in the actuator. The actuator is a swing-arm assembly driven by a voice coil motor. A closed-loop positioning servo controls the movement of the actuator. An embedded servo pattern supplies feedback to the positioning servo to keep the read/write heads centered over the desired track.

The actuator assembly is balanced to allow vertical or horizontal mounting without adjustment.

When the drive is powered off, the actuator automatically moves the head to the actuator ramp outside of the disk where it parks.

4 Drive Characteristics

This section describes the characteristics of the drive.

4.1 Default Logical Drive Parameters

The default of the logical drive parameters in Identify Device data is as shown below.

| Description | 6TB SATA Model | | 4TB SATA Model | | 2TB SATA Model |
|-----------------------------------|-------------------|-------------------|-------------------|-------------------|-------------------|
| Physical Layout | | | | | |
| Label capacity | 6TB | | 4TB | | 2TB |
| Bytes per sector | 512e | 4,096 | 512e, 512n | 4,096 | 512n |
| Number of heads | 8 | 8 | 6 | 6 | 6 |
| Number of disks | 4 | 4 | 3 | 3 | 3 |
| Logical Layout¹ | | | | | |
| Bytes per sector | 512 | 4,096 | 512 | 4096 | 512 |
| Number of sectors | 11,721,045,168 | 1,465,130,646 | 7,814,037,168 | 976,754,646 | 3,907,029,168 |
| Total logical data bytes | 6,001,175,126,016 | 6,001,175,126,016 | 4,000,787,030,016 | 4,000,787,030,016 | 2,000,398,934,016 |

Table 2 Formatted Capacity

Notes:

¹ Logical layout: Logical layout is an imaginary drive parameter (that is, the number of heads) which is used to access the drive from the system interface. The Logical layout to Physical layout (that is, the actual Head and Sectors) translation is done automatically in the drive. The default setting can be obtained by issuing an IDENTIFY DEVICE command.

4.2 Data Sheet

| Description | 6TB 4096 SATA Model | 4TB 512n SATA Model | 4TB 4096 SATA Model | 2TB 512n SATA Model |
|--|---------------------|---------------------|---------------------|---------------------|
| Max data transfer rate (Mbps) | 2,300 | 2,240 | 2,300 | 2,240 |
| Max interface transfer rate (MB/s) | 600 | 600 | 600 | 600 |
| Typical max sustained transfer rate (MB/s) | 255 | 233 | 255 | 233 |
| Typical max sustained transfer rate (MiB/s) | 243 | 222 | 243 | 222 |
| Data buffer size (MiB) | 256 | 256 | 256 | 256 |
| Rotational speed (RPM) | 7,200 | 7,200 | 7,200 | 7,200 |
| Recording density- max (kbpi) | 1,861 | 1,791 | 1,861 | 1,791 |
| Track density (ktpi) | 420 | 420 | 374 | 420 |
| Areal density - max (Gbits/in ²) | 782 | 753 | 696 | 753 |

Table 3 Data Sheet

4.3 World Wide Name Assignment

| Description | 6TB SATA Model |
|----------------------------|----------------|
| OUI | 000CCAh |
| Block Assignment (initial) | 98h (Thailand) |

| Description | 4TB SATA Model |
|----------------------------|----------------|
| OUI | 000CCAh |
| Block Assignment (initial) | 97h (Thailand) |

| Description | 2TB SATA Model |
|----------------------------|---------------------|
| OUI | 000CCAh |
| Block Assignment (initial) | CAh, CBh (Thailand) |

Table 4 World Wide Name Assignment

4.4 Drive Organization

4.4.1 Drive Format

Upon shipment from Western Digital manufacturing, the drive satisfies the sector continuity in the physical format by means of the defect flagging strategy described in Section 5 on page 26 in order to provide the maximum performance to users.

4.4.2 Cylinder Allocation

Physical cylinder is calculated from the starting data track of 0. It is not relevant to logical CHS. Depending on the capacity some of the inner zone cylinders are not allocated.

Data Cylinder

This cylinder contains the user data which can be sent and retrieved via read/write commands and a spare area for reassigned data.

Spare Cylinder

The spare cylinder is used by Western Digital manufacturing and includes data sent from a defect location.

4.5 Performance Characteristics

Drive performance is characterized by the following parameters:

- Command overhead
- Mechanical positioning
 - Seek time
 - Latency
- Data transfer speed
- Buffering operation (Look ahead/Write cache)

All the above parameters contribute to drive performance. There are other parameters that contribute to the performance of the actual system. This specification defines the characteristics of the drive, not the characteristics of the system throughput which depends on the system and the application.

The terms “Typical” and “Max” are used throughout this specification with the following meanings:

Typical The average of the drive population tested at nominal environmental and voltage conditions.

Max The maximum value measured on any one drive over the full range of the environmental and voltage conditions. (See Section 6.2, “Environment” and Section 6.3, “DC Power Requirements”)

4.5.1 Mechanical Positioning

4.5.1.1 Average Seek Time

(without command overhead, including settling)

| Command Type | Typical (ms) | Max (ms) |
|--------------|--------------|----------|
| Read | 7.4 | 10.0 |
| Write | 8.2 | 11.0 |

Table 5 Average Seek Time

4.5.1.2 Single Track Seek Time

(without command overhead, including settling)

Common to all models and all seek modes

| Function | Typical (ms) | Max (ms) |
|----------|--------------|----------|
| Read | 0.23 | 0.25 |
| Write | 0.32 | 0.45 |

Table 6 Single Track Seek Time

4.5.1.3 Average Latency

| Rotational Speed | Time for a Revolution (ms) | Average Latency (ms) |
|------------------|----------------------------|----------------------|
| 7200 RPM | 8.33 | 4.16 |

Table 7 Latency Time

4.5.2 Drive Ready Time

| Power on to Drive Ready | Typical (sec) | Max (sec) |
|-------------------------|---------------|-----------|
| 6TB | 20 | 30 |
| 4TB | 20 | 30 |
| 2TB | 20 | 30 |

Table 8 Drive Ready Time

Drive Ready The condition in which the drive is able to perform a media access command (such as read, write) immediately.

Power on This includes the time required for the internal self-diagnostics.

4.5.3 Operating Modes

4.5.3.1 Operating Mode Descriptions

| Operating Mode | Description |
|-------------------------|---|
| Spin up | Period of time from 0 rpm to full rpm |
| Start up | Period of time from power on to drive ready |
| Seek | Seek operation mode |
| Write | Write operation mode |
| Read | Read operation mode |
| Active | Drive is able to perform a media access command (such as read, write) immediately |
| Idle_0 | Drive Ready, not performing I/O; drive may power down selected electronics to reduce power without increasing response time |
| Idle_A | Drive Ready, not performing I/O; drive may power down selected electronics to reduce power without increasing response time |
| Idle_B | Spindle rotation at 7200 RPM with heads unloaded |
| Idle_C/Standby_Y | Spindle rotation at low RPM with heads unloaded |
| Standby_Z | Actuator is unloaded and spindle motor is stopped. Commands can be received immediately |
| Sleep (SATA) | Actuator is unloaded and spindle motor is stopped. Only soft reset or hard reset can change the mode to Standby_Z |

Note: Upon power down or spindle stop a head locking mechanism will secure the heads in the OD parking position.

4.5.3.2 Mode Transition Times

Mode transition times are shown below.

| From | To | RPM | Typical (sec) |
|-----------|--------|---------------|---------------|
| Idle_B | Active | 7200 | 1 |
| Idle_C | Active | 6300 --> 7200 | 4 |
| Standby_Y | Active | 6300 --> 7200 | 4 |
| Standby_Z | Active | 0 --> 7200 | 15 |

Table 9 6TB Mode Transition Times

| From | To | RPM | Typical (sec) |
|-----------|--------|---------------|---------------|
| Idle_B | Active | 7200 | 1 |
| Idle_C | Active | 6300 --> 7200 | 4 |
| Standby_Y | Active | 6300 --> 7200 | 4 |
| Standby_Z | Active | 0 --> 7200 | 15 |

Table 10 4TB Mode Transition Times

Note: Maximum transition time of 30 seconds based on drive timeout value

5 Defect Flagging Strategy

Media defects are remapped to the next available sector during the Format Process in manufacturing. The mapping from LBA to the physical locations is calculated by an internally maintained table.

5.1 Shipped Format

- Data areas are optimally used.
 - No extra sector is wasted as a spare throughout user data areas.
 - All pushes generated by defects are absorbed by the spare tracks of the inner zone.
-

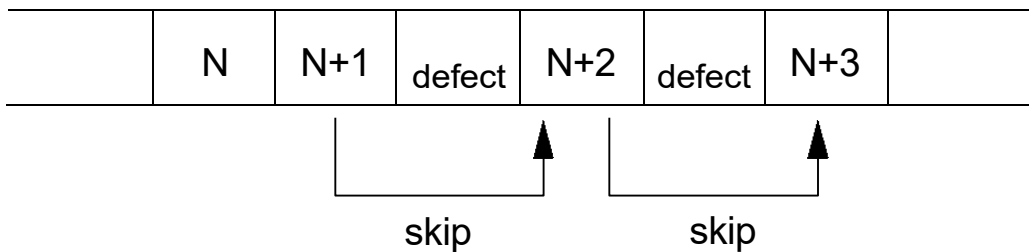

Figure 1 PList Physical Format

Defects are skipped without any constraint, such as track or cylinder boundary. The calculation from LBA to physical is done automatically by internal table.

6 Specification

6.1 Electrical Interface

6.1.1 Connector Location

Refer to the following illustration to see the location of the connectors.

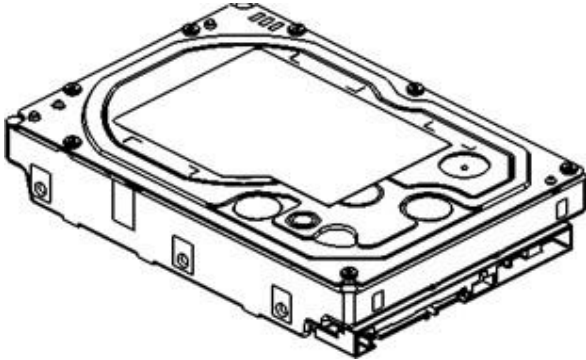

Figure 2 Connector Location

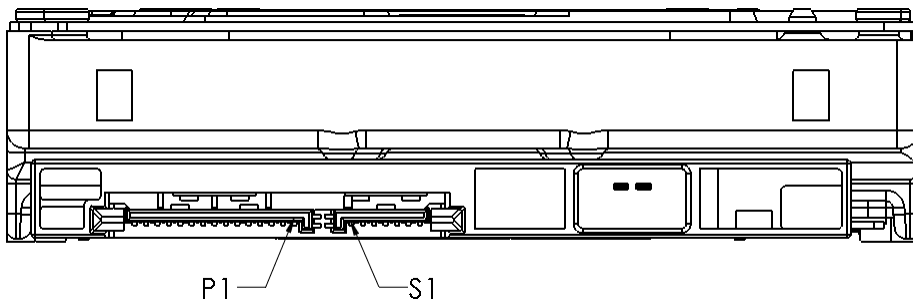

Figure 3 Connector Pin Assignments

6.1.1.1 Signal Connector (SATA)

A Serial ATA device may be either directly connected to a host or connected to a host through a cable.

For direct connection, the device plug connector is inserted directly into a backplane connector. The device plug connector and the backplane connector incorporate features that enable the direct connection to be hot pluggable and blind mated.

For connection via cable, the device signal plug connector mates with the signal cable receptacle connector on one end of the cable. The signal cable receptacle connector on the other end of the cable is inserted into a host signal plug connector. The signal cable wire consists of two twinax sections in a common outer sheath.

Besides the signal cable, there is also a separate power cable for the cabled connection. A Serial ATA power cable includes a power cable receptacle connector on one end and may be directly connected to the host power supply on the other end or may include a power cable receptacle on the other end. The power cable receptacle connector on one end of the power cable mates with the device power plug connector. The other end of the power cable is attached to the host as necessary.

6.1.2 Signal Definition (SATA)

SATA has receivers and drivers to be connected to TX+/- and RX +/- Serial data signal.
Defines the signal names of I/O connector pin and signal name.

| | No. | Plug Connector Pin Definition | | Signal | I/O |
|--|-----|-------------------------------|--|------------------|--------|
| Signal | S1 | Gnd | 2nd mate | Gnd | |
| | S2 | A+ | Differential signal A from Phy | RX+ | Input |
| | S3 | A- | | RX- | Input |
| | S4 | Gnd | 2nd mate | Gnd | |
| | S5 | B- | Differential signal B from Phy | TX- | Output |
| | S6 | B+ | | TX+ | Output |
| | S7 | Gnd | 2nd mate | Gnd | |
| Key and spacing separate signal and power segments | | | | | |
| Power | P1 | Reserved* | Not used (P1 and P2 tied internally) | Reserve | |
| | P2 | Reserved* | Not used (P1 and P2 tied internally) | Reserve | |
| | P3 | Reserved* or PWDIS* (option) | Not used (P1, P2, and P3 tied internally) or Enter/Exit Power Disable (option) | Reserve or PWDIS | |
| | P4 | Gnd | 1st mate | Gnd | |
| | P5 | Gnd | 2nd mate | Gnd | |
| | P6 | Gnd | 2nd mate | Gnd | |
| | P7 | 5V | 5V power, Precharge, 2nd Mate | 5V | |
| | P8 | 5V | 5V power | 5V | |
| | P9 | 5V | 5V power | 5V | |
| | P10 | Gnd | 2nd mate | Gnd | |
| | P11 | Reserved | Support staggered spin-up and LED activity VDih max=2.1V | Reserve | |
| | P12 | Gnd | 1st mate | Gnd | |
| | P13 | 12V | 12V power, Precharge, 2nd mate | 12V | |
| | P14 | 12V | 12V power | 12V | |
| | P15 | 12V | 12V power | 12V | |

Table 11 Interface Connector Pins and I/O Signals

* SATA Specification Revision 3.1 and prior revisions assigned 3.3V to pins P1, P2, and P3. In addition, device plug pins P1, P2, and P3 were required to be bused together. In the standard configuration of this product, P3 is connected with P1 and P2 and this product behaves as SATA 3.1 or prior version product in a system designed to SATA 3.2 system that does not support the 3.3 feature. For product with the optional SATA 3.3 Power Disable Feature supported, P3 is now assigned as the POWER DISABLE CONTROL PIN. If P3 is driven HIGH (2.1V-3.6V max), power to the drive circuitry will be disabled. Drives with this optional feature WILL NOT POWER UP in systems designed to SATA Spec Revision 3.1 or earlier because P3 driven HIGH will prevent the drive from powering up.

6.1.2.1 TX+ / TX- (SATA)

These signals are the outbound high-speed differential signals that are connected to the serial ATA cable

6.1.2.2 RX+ / RX- (SATA)

These signals are the inbound high-speed differential signals that are connected to the serial ATA cable.

6.1.2.3 5V Pre-charge

+5 Vdc that is available on the extended pins. It is used for Pre-charge when connected to backplane incorporated feature.

6.1.2.4 12V Pre-charge

+12 Vdc that is available on the extended pins. It is used for Pre-charge when connected to backplane incorporated feature.

6.1.3 Out-of-Band Signaling (SATA)

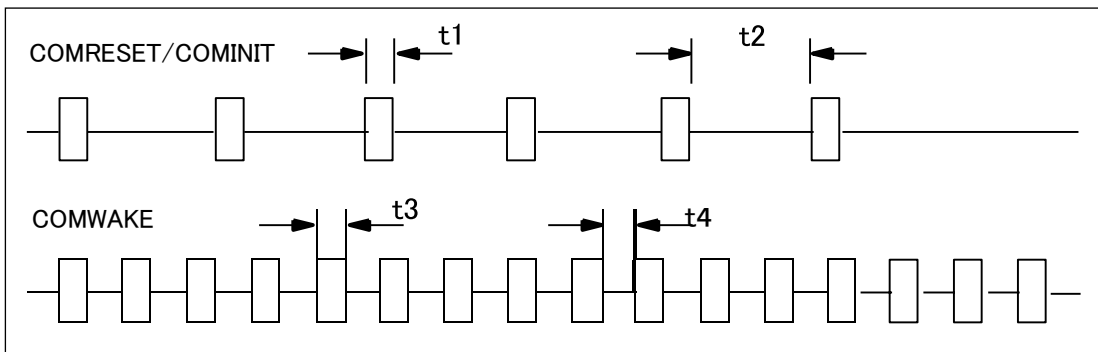

Figure 4 The Timing of COMRESET, COMINIT and COMWAKE

| | PARAMETER DESCRIPTION | Nominal (ns) |
|----|-----------------------|--------------|
| t1 | ALIGN primitives | 106.7 |
| t2 | Spacing | 320.0 |
| t3 | ALIGN primitives | 106.7 |
| t4 | Spacing | 106.7 |

Table 12 Parameter Descriptions

6.1.4 Voltage and Ground Signals

The 12V and 5V contacts provide all of the voltages required by the drive. The two voltages share a common ground plane to which all of the ground contacts are connected.

6.1.5 Ready LED Output

The drive provides an open-drain driver with 15mA of current sink capability to the Ready LED Output signal. The cathode of the LED should be connected to this signal. The LED and the current-limiting resistor must be provided by the enclosure.

6.2 Environment

6.2.1 Temperature and Humidity

| | |
|---|--|
| System Responsibility | |
| The system is responsible for maintaining drive sensor temperature below 65°C. Drive sensor temperature is reported using SMART SCT (SATA). | |
| Operating Ambient Conditions | |
| Temperature | 5 to 60°C |
| Relative humidity | 8 to 90% non-condensing |
| Maximum wet bulb temperature | 29.4°C non-condensing |
| Maximum temperature gradient | 20°C/Hour |
| Altitude | -300 to 3,048 m |
| Non-Operating Conditions | |
| Temperature | -40 to 70°C (Storage 0 to 70°C) |
| Relative humidity | 5 to 95% non-condensing |
| Maximum wet bulb temperature | 35°C non-condensing |
| Maximum temperature gradient | 30°C/Hour |
| Altitude | -300 to 12,000 m (Inside dashed-dotted line of Figure 4) |

Table 13 Temperature and Humidity

Notes:

1. Non-condensing conditions should be maintained at all times.

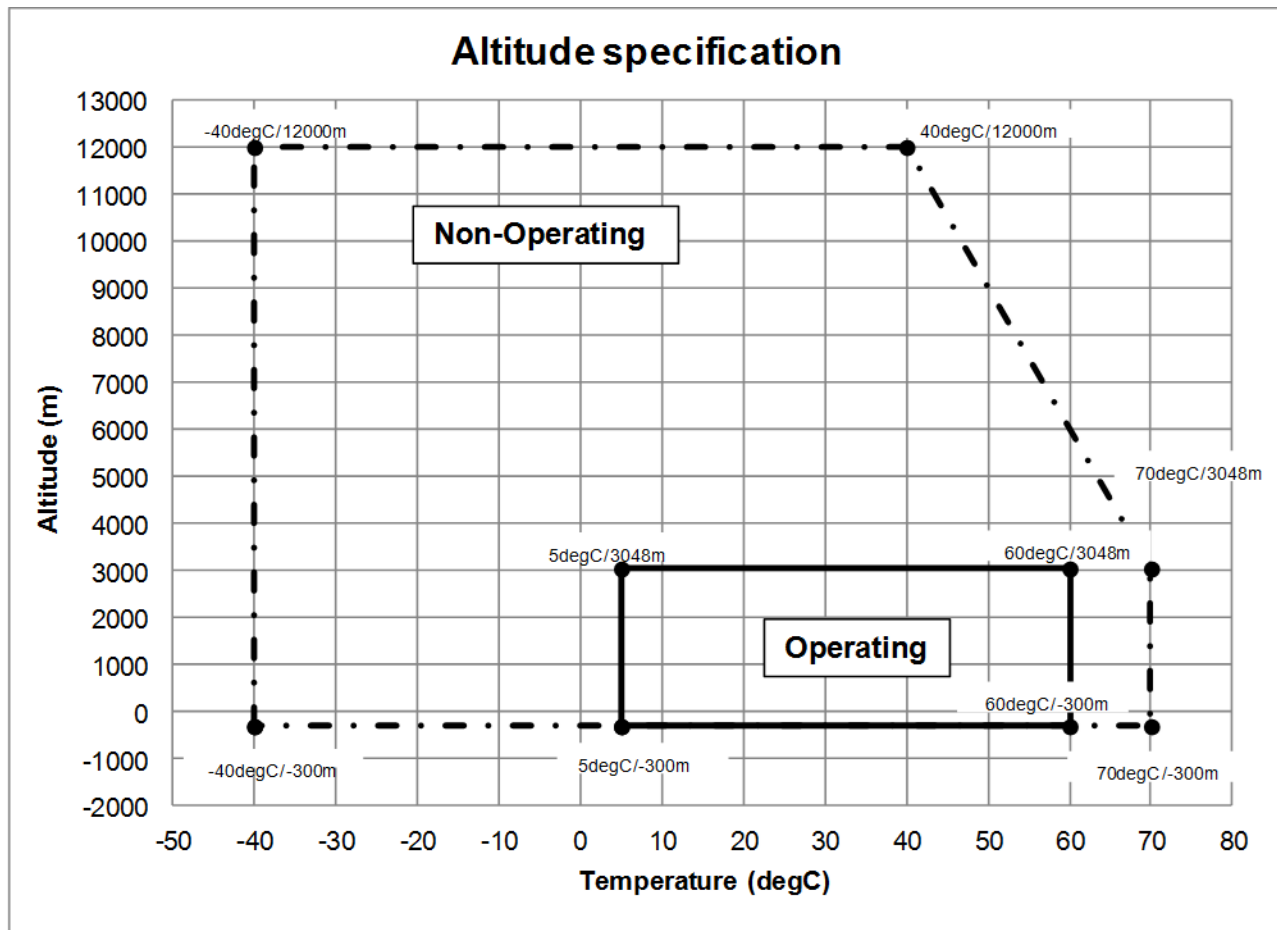

Figure 5 Limits of Temperature and Altitude

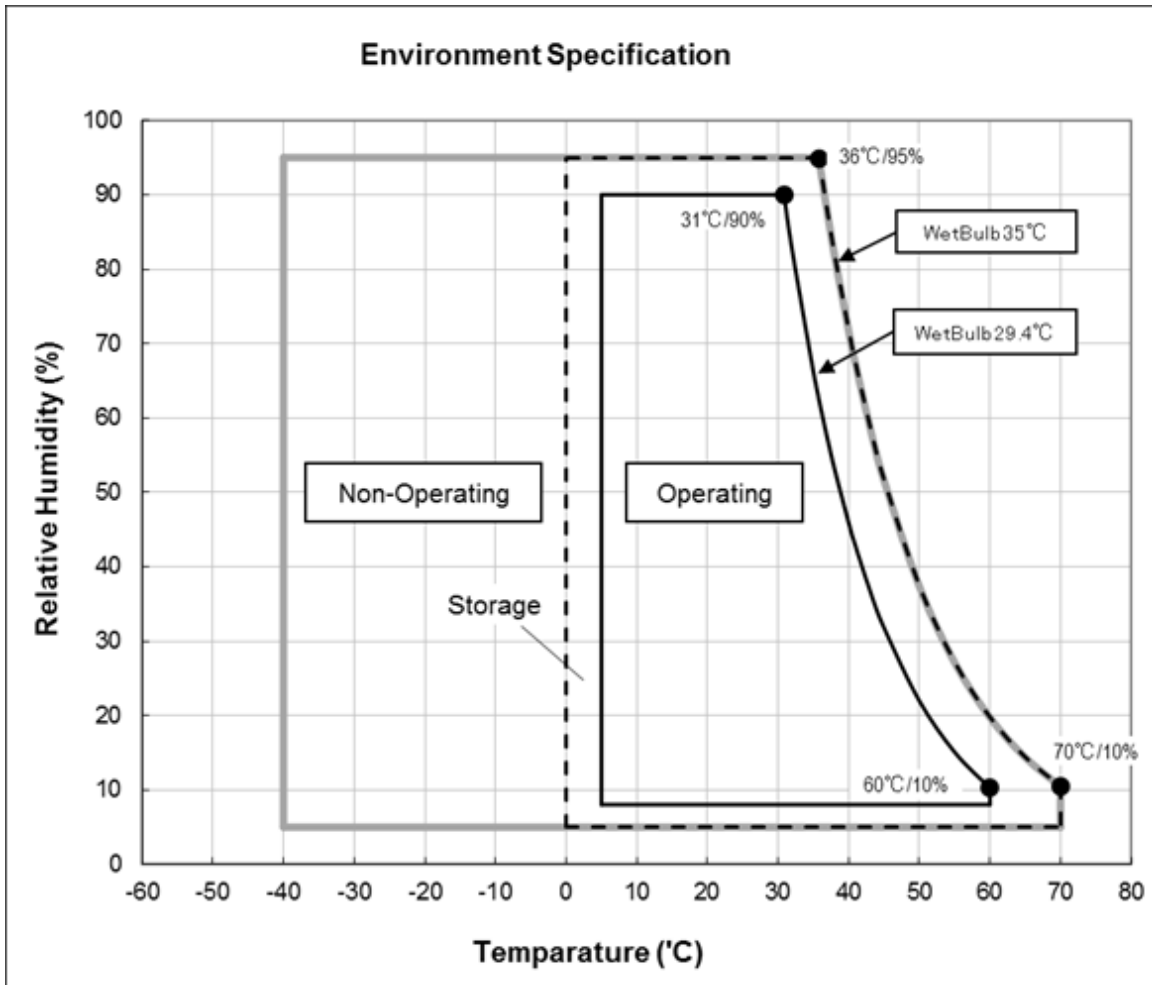

Figure 6 Limits of Temperature and Humidity

6.2.2 Storage Requirements

6.2.2.1 Packaging

The drive or option kit must be heat-sealed in a moisture barrier bag with bag supplied by Western Digital.

6.2.2.2 Storage Time

The drive may not remain inoperative for a period of more than one year. During this time, the maximum time the drive may be stored after the bag is opened is six months.

6.2.3 Corrosion Test

The drive shows no sign of corrosion inside and outside of the hard disk assembly and is functional after being subjected to seven days at 50°C with 90% relative humidity.

6.2.4 Atmospheric Condition

Environments that contain elevated levels of corrosives (e.g., hydrogen sulfide, sulfur oxides, or hydrochloric acid, sulfurous gases, chlorine and nitric oxide) should be avoided and ideally kept below G2 severity level defined in ISA-71.04-1985. Care must be taken to avoid using any compound/material in a way that creates an elevated level of corrosive materials in the atmosphere surrounding the disk drive. Vulcanized rubber is an example of a material which may contain corrosive compound/materials.

Care must also be taken to avoid the use of any organometallic (e.g., organosilicones or organotins) compound / material in a way that creates elevated vapor levels of these compounds / materials in the atmosphere surrounding the disk drive. Silicone-based Thermal Interface Materials (TIM), silicone-based tapes, caulking / RTV pastes, silicone rubbers and silicone oil lubricants are examples of materials which may create elevated vapor levels of organometallic compound / materials.

Use of the disk drive in these abnormal or other chemically-challenging environments is not recommended and increases the risk for failure. If any of these materials are considered in system design, it is recommended to consult with Western Digital.

6.3 DC Power Requirements

Connections to the drive should be made in a Safety Extra Low Voltage (SELV) circuit that can provide sufficient 5V and 12V current, as described in this section.

The following voltage specifications apply at the drive power connector.

There are no power on or off voltage sequencing requirements.

The drive provides resettable over-current protection on both 5V and 12V. Over-current protection will reset during a power cycle.

Hot-plug or unplug is supported for all models, with the following exception:

SATA cabled connection using separated (two part) power and signal cables

Initial capacitance is the amount of capacitance to charge during the initial hot-plug event.

Dependent on the selected SATA model the drive will support SATA 3.3 Power Disable Feature Support. (Refer to section 1.1)

Table values for current and power are considered 'typical' values. Typical is defined as observed average or observed maximum in a sample of 10 drives per model under voltage conditions of 5.0 and 12.0V at the drive reported temperatures as noted.

6.3.1 Input Voltage

| Input Voltage | Voltage Tolerance ¹ | Absolute Max Spike Voltage | Supply Voltage Rise Time | Initial Capacitance |
|------------------|--------------------------------|----------------------------|--------------------------|---------------------|
| +5 Volts Supply | 5V ± 5% | -0.3 to 5.5V | 0 to 200ms | 10uF |
| +12 Volts Supply | 12V ± 5% | -0.3 to 15.0V | 0 to 400ms | 1uF |

Table 14 Input Voltage

Caution: To avoid damage to the drive electronics, power supply voltage spikes must not exceed specifications.

¹ During start up and operation

Start-up peak AC and DC on 5V and 12V

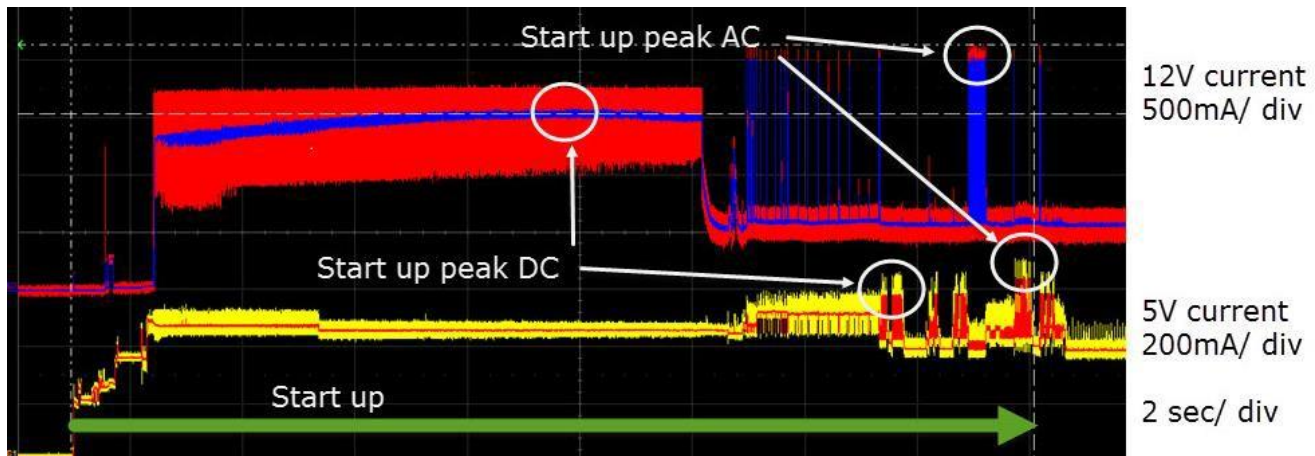

Figure 7 Start-up Current Waveforms

Idle_C, Standby_Y recovery peak AC and DC on 12V

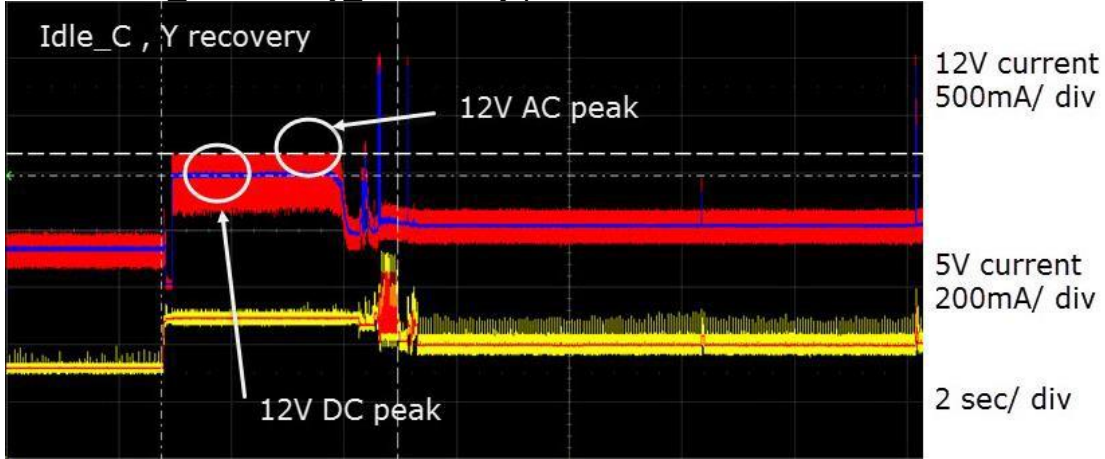

Figure 8 Idle_C Standby_Y Recovery Current Waveform

Standby_Z recovery peak AC and DC on 12V

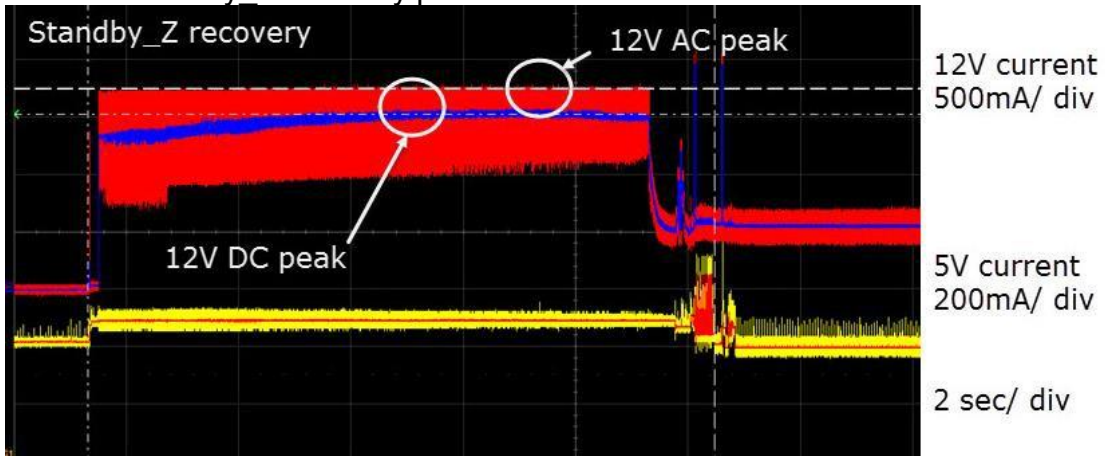

Figure 9 Standby_Z Recovery Current Waveform

6.3.2 Power Supply Current

6.3.2.1 SATA, 6TB, Block Size 4k, 6Gb/sec

Model: SATA @ 6Gb/sec
Block size: 4k

| | IO/Sec | 6TB Model | | Power Watts |
|---------------------------|--------|--------------------|---------------------|----------------|
| | | Current +5V Amp | Current +12V Amp | |
| Start up Peak DC [1] | | 0.32 | 1.53 | |
| Start up Peak AC | | 0.59 | 2.07 | |
| Idle_0, Avg | | 0.21 | 0.40 | 5.9 |
| Idle Ripple | | 0.13 | 0.29 | |
| Random Peak [4] | | 0.52 | 1.85 | |
| Random RW 8kB Qd=1 Avg | 40 | 0.23 | 0.49 | 7.0 |
| Random RW 4kB Qd=1 Avg | 138 | 0.23 | 0.59 | 8.2 |
| Random RW 4kB Qd=4 Avg | 202 | 0.24 | 0.81 | 11.0 |
| Random R 4kB Qd=8 Avg [5] | 230 | 0.24 | 0.81 | 10.9 |
| Sequential Read Peak [4] | | 0.62 | | |
| Sequential Read Avg [2] | | 0.52 | 0.42 | 7.6 |
| Sequential Write Peak [4] | | 0.48 | | |
| Sequential Write Avg [2] | | 0.42 | 0.46 | 7.6 |

| Power Save Modes (PHY state: Active) | Current | | Power Watts | Power Saved Watts[3] | Recovery [1] | |
|---|---------|----------|----------------|----------------------------|----------------|----------------|
| | +5V Amp | +12V Amp | | | 12V DC Peak | 12V AC Peak |
| Idle_A | 0.21 | 0.40 | 5.9 | 0.0 | | |
| Idle_B | 0.12 | 0.34 | 4.7 | 1.2 | | |
| Idle_C | 0.12 | 0.25 | 3.6 | 2.3 | 1.00 | 1.17 |
| Standby_Y | 0.12 | 0.25 | 3.6 | 2.3 | 1.00 | 1.17 |
| Sleep, Standby_Z | 0.11 | 0.005 | 0.6 | 5.3 | 1.56 | 1.78 |

PHY power condition
Partial
Slumber

| |
|-----|
| 0.2 |
| 0.2 |

Notes

- Sample size 10 HDD per model
- Temperature DE temperature = 40°C (25°C for Spin up)
- Write Cache Enable Off
- Bandwidth All measurements are bandwidth limited to 20MHz
- PHY Single port, 6Gb/s
- [1] 200ms windowed average
- [2] Max transfer rate
- [3] Power saved compared to Idle_0
- [4] Maximum single peak in test samples
- [5] Maximum power workload

Table 15 SATA Power Consumption, 6TB, 4k

6.3.2.2 SATA, 4TB, Block Size 4k, 6Gb/sec

Model: SATA @ 6Gb/sec
Block size: 4k

| | IO/Sec | 4TB Model | | Power Watts |
|---------------------------|--------|--------------------|---------------------|----------------|
| | | Current +5V Amp | Current +12V Amp | |
| Start up Peak DC [1] | | 0.28 | 1.54 | |
| Start up Peak AC | | 0.46 | 1.96 | |
| Idle_0, Avg | | 0.21 | 0.32 | 4.9 |
| Idle Ripple | | 0.12 | 0.26 | |
| Random Peak [4] | | 0.52 | 1.78 | |
| Random RW 8kB Qd=1 Avg | 40 | 0.23 | 0.41 | 6.1 |
| Random RW 4kB Qd=1 Avg | 139 | 0.23 | 0.51 | 7.3 |
| Random RW 4kB Qd=4 Avg | 206 | 0.24 | 0.74 | 10.1 |
| Random R 4kB Qd=8 Avg [5] | 233 | 0.24 | 0.73 | 9.9 |
| Sequential Read Peak [4] | | 0.64 | | |
| Sequential Read Avg [2] | | 0.52 | 0.34 | 6.7 |
| Sequential Write Peak [4] | | 0.49 | | |
| Sequential Write Avg [2] | | 0.42 | 0.38 | 6.7 |

| Power Save Modes (PHY state: Active) | Current | | Power Watts | Power Saved Watts[3] | Recovery [1] | |
|---|---------|----------|----------------|----------------------------|----------------|----------------|
| | +5V Amp | +12V Amp | | | 12V DC Peak | 12V AC Peak |
| Idle_A | 0.21 | 0.32 | 4.9 | 0.0 | | |
| Idle_B | 0.12 | 0.27 | 3.9 | 1.1 | | |
| Idle_C | 0.12 | 0.20 | 3.0 | 1.9 | 1.00 | 1.17 |
| Standby_Y | 0.12 | 0.20 | 3.0 | 1.9 | 1.00 | 1.17 |
| Sleep, Standby_Z | 0.11 | 0.005 | 0.6 | 4.3 | 1.56 | 1.78 |
| PHY power condition Partial | | | | 0.2 | | |
| Slumber | | | | 0.2 | | |

Notes

- Sample size 10 HDD per model
- Temperature DE temperature = 40°C (25°C for Spin up)
- Write Cache Enable Off
- Bandwidth All measurements are bandwidth limited to 20MHz
- PHY Single port, 6Gb/s
- [1] 200ms windowed average
- [2] Max transfer rate
- [3] Power saved compared to Idle_0
- [4] Maximum single peak in test samples
- [5] Maximum power workload

Table 16 SATA Power Consumption, 4TB, 4k

6.3.2.3 SATA, 2TB & 4TB, Block Size 512n, 6Gb/sec

Model: SATA @ 6Gb/sec
Block size: 512 native

| | IO/Sec | 2TB & 4TB Model | | Power Watts |
|---------------------------|--------|--------------------|---------------------|----------------|
| | | Current +5V Amp | Current +12V Amp | |
| Start up Peak DC [1] | | 0.35 | 1.56 | |
| Start up Peak AC | | 0.60 | 1.98 | |
| Idle_0, Avg | | 0.20 | 0.35 | 5.2 |
| Idle Ripple | | 0.13 | 0.26 | |
| Random Peak [4] | | 0.78 | 1.88 | |
| Random RW 8kB Qd=1 Avg | 40 | 0.23 | 0.45 | 6.6 |
| Random RW 4kB Qd=1 Avg | 83 | 0.22 | 0.56 | 7.8 |
| Random RW 4kB Qd=4 Avg | 114 | 0.22 | 0.64 | 8.8 |
| Random R 4kB Qd=8 Avg [5] | 144 | 0.22 | 0.70 | 9.5 |
| Sequential Read Peak [4] | | 0.78 | | |
| Sequential Read Avg [2] | | 0.51 | 0.36 | 6.9 |
| Sequential Write Peak [4] | | 0.51 | | |
| Sequential Write Avg [2] | | 0.42 | 0.40 | 6.9 |

| Power Save Modes (PHY state: Active) | Current | | Power Watts | Power Saved Watts[3] | Recovery [1] | |
|---|---------|----------|----------------|----------------------------|----------------|----------------|
| | +5V Amp | +12V Amp | | | 12V DC Peak | 12V AC Peak |
| Idle_A | 0.20 | 0.35 | 5.2 | 0.0 | | |
| Idle_B | 0.11 | 0.30 | 4.2 | 1.0 | | |
| Idle_C | 0.11 | 0.22 | 3.2 | 2.0 | 1.00 | 1.17 |
| Standby_Y | 0.11 | 0.22 | 3.2 | 2.0 | 1.00 | 1.17 |
| Sleep, Standby_Z | 0.11 | 0.01 | 0.6 | 4.6 | 1.56 | 1.78 |
| PHY power condition Partial | | | | 0.2 | | |
| Slumber | | | | 0.2 | | |

Notes

- Sample size 10 HDD per model
- Temperature DE temperature = 40°C (25°C for Spin up)
- Write Cache Enable Off
- Bandwidth All measurements are bandwidth limited to 20MHz
- PHY Single port, 6Gb/s
- [1] 200ms windowed average
- [2] Max transfer rate
- [3] Power saved compared to Idle_0
- [4] Maximum single peak in test samples
- [5] Maximum power workload

Table 17 SATA Power Consumption, 2TB & 4TB, 512n

6.3.3 Power Line Noise Limits

| | Noise Voltage (mV pp) | Frequency Range |
|---------|-----------------------|-----------------|
| +5V DC | 250 | 100Hz-20MHz |
| | | |
| +12V DC | 800 | 100Hz-8KHz |
| | 450 | 8KHz-100KHz |
| | 250 | 100KHz-20MHz |

Table 18 Allowable Power Supply Noise Limits at Drive Power Connector

During drive operation, both 5 and 12-volt ripple are generated by the drive due to dynamic loading of the power supply. This voltage ripple will add to existing power supply voltage ripple. The sum is the power line noise.

To prevent significant performance loss, the power line noise level when measured at the drive power connector should be kept below the limits in the above table.

6.3.4 Power Consumption Efficiency

| Power Consumption Efficiency at Idle_0 | SATA W/GB |
|--|-----------|
| 6TB | 0.00102 |
| 4TB | 0.00128 |
| 2TB | 0.00128 |

Table 19 Power Consumption Efficiency

6.4 Reliability

6.4.1 Data Integrity

When the write cache option is disabled, no customer data is lost during power loss. If the write cache option is active or has been recently used, some data loss can occur during power loss. To prevent the loss of data at power off, confirm the successful completion of a FLUSH CACHE (E7h) or FLUSH CACHE EXT (EAh) command.

6.4.2 Cable Noise Interference

To avoid any degradation of performance throughput or error rate when the interface cable is routed on top or comes in contact with the HDA assembly, the drive must be grounded electrically to the system frame by four screws. The common mode noise or voltage level difference between the system frame and power cable ground or AT interface cable ground should be in the allowable level specified in the power requirement section.

6.4.3 Load/Unload

The product supports a minimum of 600,000 normal load/unloads in a 40° C environment. Load/unload is invoked by transition of the HDD's power mode. (Chapter 4.5.3 Operating Modes)

Idle <-> Unload idle
Idle <-> Low rpm idle

6.4.4 Start/Stop Cycles

The drive withstands a minimum of 50,000 start/stop cycles in a 40° C environment and a minimum of 10,000 start/stop cycles in extreme temperature or humidity within the operating range.

6.4.5 Preventive Maintenance

None

6.4.6 Data Reliability

Probability of not recovering data is 1 in 10^{15} bits read.

LDPC on the fly/ offline data correction

- 4608 bit LDPC
- This implementation recovers maximum 2500 bits single burst error by on the fly correction and maximum 3500 bits single burst error by offline correction

6.5 Mechanical Specifications

6.5.1 Physical Dimensions

The following table shows the physical dimensions of the drive.

| Height (mm) | Width (mm) | Length (mm) | Weight (grams) |
|-------------|--------------|-------------|----------------|
| 26.1 Max | 101.6 ± 0.25 | 147 Max | 715 Max |

Table 20 Physical Dimensions

6.5.1.1 SATA

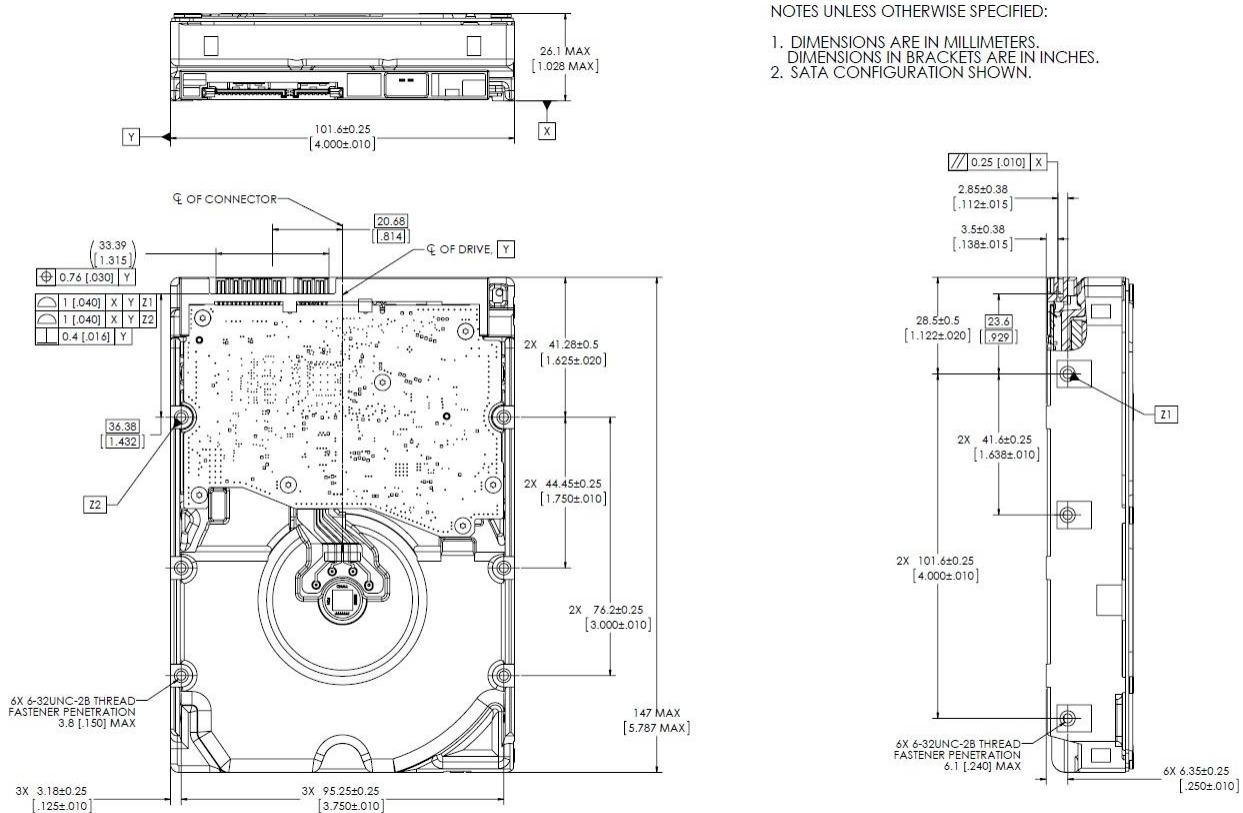

Figure 10 Top, Bottom, Side Views and Mechanical Dimensions, with Connector Position (SATA)

All dimensions are in millimeters.

6.5.2 Drive Mounting

The drive will operate in all axes (6 directions).

Performance and error rate will stay within specification limits if the drive is operated in other orientations than that in which it was formatted.

For reliable operation, the drive must be mounted in the system securely enough to prevent excessive motion or vibration of the drive during seek operation or spindle rotation, using appropriate screws or equivalent mounting hardware.

The recommended mounting screw torque is 0.6 - 1.0 Nm (6-10 Kgf.cm).

The recommended mounting screw depth is 3.8 mm maximum for bottom and 6.1 mm maximum for horizontal mounting.

Drive level vibration test and shock test are to be conducted with the drive mounted to the table using the bottom four screws.

6.5.3 Heads Unload and Actuator Lock

Heads are moved out from disks (unload) to protect the disk data during shipping, moving, or storage. Upon power down, the heads are automatically unloaded from disk area and the locking mechanism of the head actuator will secure the heads in unload position.

6.6 Vibration and Shock

All vibration and shock measurements recorded in this section are made with a drive that has no mounting attachments for the systems. The input power for the measurements is applied to the normal drive mounting points.

6.6.1 Operating Vibration

6.6.1.1 Random Vibration (Linear)

The test is 30 minutes of random vibration using the power spectral density (PSD) levels shown below in each of three mutually perpendicular axes. The disk drive will operate without non-recoverable errors when subjected to the below random vibration levels.

| Frequency | 5 Hz | 17 Hz | 45 Hz | 48 Hz | 62 Hz | 65 Hz | 150 Hz | 200 Hz | 500 Hz | RMS (m/sec ²) |
|--|-------------|-------------|-------------|-------------|-------------|-------------|-------------|-------------|-------------|---------------------------|
| [(m/sec ²) ² /Hz] | 1.9 x 10E-3 | 1.1 x 10E-1 | 1.1 x 10E-1 | 7.7 x 10E-1 | 7.7 x 10E-1 | 9.6 x 10E-2 | 9.6 x 10E-2 | 4.8 x 10E-2 | 4.8 x 10E-2 | 6.57 |

Table 21 Random Vibration PSD Profile Break Points (operating)

The overall RMS (Root Mean Square) level is 6.57 m/sec² (0.67 G).

6.6.1.2 Swept Sine Vibration (Linear)

The drive will meet the criteria shown below while operating in the specified conditions:

- No errors occur with 4.9 m/sec² (0.5 G) 0 to peak, 5 to 300 to 5 Hz sine wave, 0.5 oct/min sweep rate with 3-minute dwells at two major resonances
- No data loss occurs with 9.8 m/sec² (1 G) 0 to peak, 5 to 300 to 5 Hz sine wave, 0.5 oct/min sweep rate with 3-minute dwells at two major resonances

6.6.1.3 Random Vibration (Rotational)

The drive will meet the criteria shown below while operating in the specified conditions:

- Less than 20% performance degradation
- The overall RMS (Root Mean Square) level of vibration is 12.5Rad/sec². PSD profile is shown below.

| Frequency | 20 Hz | 100 Hz | 200 Hz | 800 Hz | 1000 Hz | 1500 Hz | 1700 Hz | 2000 Hz | RMS (Rad/s ²) |
|--|----------|----------|----------|----------|----------|----------|----------|----------|---------------------------|
| [(Rad/s ²) ² /Hz] | 1.90E-02 | 1.90E-02 | 1.87E-01 | 1.87E-01 | 5.33E-02 | 7.70E-03 | 4.00E-03 | 4.00E-03 | 12.5 |

Table 22 Random Vibration (Rotational) PSD Profile Break Points

6.6.2 Non-operating Vibration

The drive does not sustain permanent damage or loss of previously recorded data after being subjected to the environment described below.

6.6.2.1 Random Vibration

The test consists of a random vibration applied for each of three mutually perpendicular axes with the time duration of 10 minutes per axis. The PSD levels for the test simulate the shipping and relocation environment shown below. The overall RMS (Root Mean Square) level of vibration is 10.2 m/sec² (1.04 G).

| Frequency | 2 Hz | 4 Hz | 8 Hz | 40 Hz | 55 Hz | 70 Hz | 200 Hz |
|----------------------------|-------|-------|-------|-------|-------|-------|--------|
| [(m/sec ²)/Hz] | 0.096 | 2.890 | 2.890 | 0.289 | 0.962 | 0.962 | 0.096 |

Table 23 Random Vibration PSD Profile Break Points (Non-operating)

6.6.2.2 Swept Sine Vibration

- 19.6 m/sec² (2 G) (Zero to peak), 5 to 500 to 5 Hz sine wave
- 0.5 oct/min sweep rate
- 3 minutes dwell at two major resonances

6.6.3 Operating Shock

The drive meets the following criteria while operating in the conditions described below. The shock test consists of 10 shock inputs in each axis and direction for total of 60. There must be a delay between shock pulses long enough to allow the drive to complete all necessary error recovery procedures.

- No error occurs with a 98.1 m/sec² (10 G) half-sine shock pulse of 11 ms duration
- No data loss occurs with a 294 m/sec² (30 G) half-sine shock pulse of 4 ms duration
- No data loss occurs with a 686 m/sec² (70 G) half-sine shock pulse of 2 ms duration

6.6.4 Non-operating Shock

The drive will operate without non-recoverable errors after being subjected to shock pulses with the following characteristics.

6.6.4.1 Trapezoidal Shock Wave

- Approximate square (trapezoidal) pulse shape
- Approximate rise and fall time of pulse is 1 ms
- Average acceleration level is 490 m/sec² (50 G). (Average response curve value during the time following the 1 ms rise time and before the 1 ms fall with a time "duration of 11 ms")
- Minimum velocity change is 4.23 m/sec

6.6.4.2 Sinusoidal Shock Wave

The shape is approximately half-sine pulse. The table below shows the maximum acceleration level and duration.

| Acceleration Level (m/sec ²) (G) | Duration (ms) |
|--|---------------|
| 2940 (300G) | 2 |
| 1470 (150G) | 11 |

Table 24 Sinusoidal Shock Wave

6.6.5 Non-operating Rotational Shock

All shock inputs shall be applied around the actuator pivot axis.

| Duration | Rad/sec ² |
|----------|----------------------|
| 1 ms | 30,000 |
| 2 ms | 20,000 |

Table 25 Rotational Shock

6.7 Acoustics

The upper limit criteria of the octave sound power levels are given in Bels relative to one picowatt and are shown in the following table. The sound power emission levels are measured in accordance with ISO 7779.

| Mode | 7200rpm (Typical / Max) |
|-----------|-------------------------|
| Idle | 2.9 / 3.4 |
| Operating | 3.6 / 4.0 |

Table 26 Sound Power Levels

Mode definition:

Idle mode The drive is powered on, disks spinning, track following, unit ready to receive and respond to interface commands.

Operating mode Continuous random cylinder selection and seek operation of the actuator with a dwell time at each cylinder. The seek rate for the drive is to be calculated as shown below:

- Dwell time = $0.5 \times 60/\text{RPM}$
- Seek rate = $0.4 / (\text{Average seek time} + \text{Dwell time})$

6.8 Identification Labels

The following labels are affixed to every drive shipped from the drive manufacturing location in accordance with the appropriate hard disk drive assembly drawing:

- A label containing the WDC logo, the WDC part number, and the statement “Made by WDC, Ltd.” or WDC approved equivalent
- A label containing the drive model number, the manufacturing date code, the formatted capacity, the place of manufacture, UL/CSA/CE/RCM mark logos, and WEEE/China RoHS logos
- A bar code label containing the drive serial number
- A label containing the jumper pin description
- A user designed label per agreement

The above labels may be integrated with other labels.

6.9 Safety

6.9.1 UL and CSA Standard Conformity

The product is qualified per UL60950-1 : Second Edition and CAN/CSA-C22.2 No.60950-1-07 Second Edition, for use in Information Technology Equipment including Electric Business Equipment.

The UL recognition or the CSA certification is maintained for the product life.

The UL and C-UL recognition mark or the CSA monogram for CSA certification appear on the drive.

6.9.2 European Safety Mark

The product is approved by UL per Test requirement: EN 60950-1:2006+A11:2009+A1:2010+A12: 2011+A2:2013 allowing the use of the UL EU mark. The GS mark is not applicable to internal devices such as this product.

6.9.3 Flammability

The printed circuit boards used in this product are made of material with the UL recognized flammability rating of V-1 or better. The flammability rating is marked or etched on the board. All other parts not considered electrical components are made of material with the UL recognized flammability rating of V-2 minimum basically.

6.9.4 Safe Handling

The product is conditioned for safe handling in regards to sharp edges and corners.

6.9.5 Substance Restriction Requirements

The product complies with the Directive 2011/65/EU of the European Parliament on the restrictions of the use of the certain hazardous substances in electrical and electronic equipment (RoHS) and with Halogen free requirements based on the electronics industry standard, IEC 61249-2-21 (<http://www.iec.ch/>).

6.9.6 Secondary Circuit Protection

The product contains both 5V and 12V over-current protection circuitry.

6.10 Electromagnetic Compatibility

When installed in a suitable enclosure and exercised with a random accessing routine at maximum data rate, the drive meets the following worldwide EMC requirements:

- European Economic Community (EEC) directive number 76/889 related to the control of radio frequency interference and the Verband Deutscher Elektrotechniker (VDE) requirements of Germany (GOP). Spectrum Management Agency (SMA) EMC requirements of Australia. The SMA has approved RCM Marking for WDC Japan.
- United States Federal Communications Commission (FCC) Rules and Regulations (Class B), Part 15. Operation is subject to the following two conditions:
 - 1) This equipment may not cause harmful interference, and
 - 2) this equipment must accept any interference received, including interference that may cause undesired operation.

NOTE: this equipment has been tested and found to comply with the limits for a class B digital device, pursuant to part 15 of the FCC rules. These limits are designed to provide reasonable protection against harmful interference in residential installation. This equipment generates, uses and can radiate radio frequency energy and if not installed and used in accordance with the instruction, may cause harmful interference to radio communications. However, there is no guarantee that interference will not occur in a particular installation. If this equipment does cause harmful interference to radio or television reception, which can be determined by turning the equipment off and on, the user is encouraged to try to correct the interference by one or more of the following measures:

- Reorient or relocate the receiving antenna.
- Increase the separation between the equipment and receiver.
- Connect the equipment into a different outlet from the receiver.
- Consult the dealer or an experienced radio/TV technician for help.

The user is cautioned that changes and modifications made to the equipment without the approval of manufacturer could void the user's authority to operate this equipment.

(IF SHIELDED CABLES WERE USED DURING TESTING, ADD THE FOLLOWING PARAGRAPH.)

In order to maintain compliance with FCC regulations, shielded cables must be used with this equipment. Operation with non- approved equipment or unshielded cables is likely to result in interference to radio and TV reception.

6.10.1 CE Mark

The product is declared to be in conformity with requirements of the following EU directives under the sole responsibility of WDC Japan, Ltd:

Council Directive 2014/30/EU on the approximation of laws of the Member States relating to electromagnetic compatibility.

6.10.2 RCM Mark

The product complies with the following Australian EMC standard:

Limits and methods of measurement of radio disturbance characteristics of information technology, EN55032 : 2015 Class B.

6.10.3 BSMI Mark

The product complies with the Taiwan EMC standard "Limits and methods of measurement of radio disturbance characteristics of information technology equipment, CNS 13438 Class B."

6.10.4 KC Mark

The product complies with the Korea EMC standard. The regulation for certification of information and communication equipment is based on “Telecommunications Basic Act” and “Radio Waves Act” Korea EMC requirements are based technically on KN32/KN35 measurement standards and limits. KC standards are likewise based on IEC standards.

6.11 Third-Party Notices

This product includes the following third party software:

bzip2

<http://www.bzip.org/index.html>

LibTomCrypt

LibTomCrypt is licensed under DUAL licensing terms.

<https://github.com/libtom/libtomcrypt/blob/develop/LICENSE>

Part 2. Interface Specification

7 General

7.1 Introduction

This specification describes the host interface of HUS726TxTALx6xx

The interface conforms to the following working documents of Information technology with certain limitations described in the chapter 7.3 “Deviations from Standard” on page 51

- Serial ATA International Organization: Serial ATA Revision 3.2
-

7.2 Terminology

Device Device indicates HUS726TxTALx6xx
Host Host indicates the system that the device is attached to.

7.3 Deviations From Standard

The device conforms to the referenced specifications, with deviations described below.

| | |
|-----------------------------------|---|
| Check Power Mode | If the Extended Power Conditions feature set is disabled and the device is in Idle mode, Check Power Mode command returns FFh by Sector Count Register, instead of returning 80h. Refer to 11.1 “Check Power Mode” for detail. |
| COMRESET | COMRESET response is not the same as that of Power On Reset. Refer to section 9.1 “Reset Response” for detail. |
| Download | Both Download Microcode and Download Microcode DMA are aborted when the device is in security locked mode. |
| COMRESET response time | During 500ms from Power On Reset, COMINIT is not returned within 10ms as a response to COMRESET. |
| Streaming Commands | When the device is in standby mode, Streaming Commands can’t be completed while waiting for the spindle to reach operating speed even if execution time exceeds specified CCTL (Command Completion Time Limit). The minimum CCTL is 50ms.CCTL is set to 50ms when the specified value is shorter than 50ms. |
| SCT Error Recovery Control | When the device is in standby mode, any command where error recovery time limit is specified can’t be completed while waiting for the spindle to reach operating speed even if execution time exceeds specified recovery time limit. The minimum time limit is 6.5 second. When the specified time limit is shorter than 6.5 second, the issued command is aborted. |

8 Registers

In Serial ATA, the host adapter contains a set of registers that shadow the contents of the traditional device registers, referred to as the Shadow Register Block. Shadow Register Block registers are interface registers used for delivering commands to the device or posting status from the device. About details, please refer to the Serial ATA Specification.

In the following cases, the host adapter sets the BSY bit in its shadow Status Register and transmits a FIS to the device containing the new contents.

- Command register is written in the Shadow Register Block
- Device Control register is written in the Shadow Register Block with a change of state of the SRST bit
- COMRESET is requested

8.1 Alternate Status Register

| Alternate Status Register | | | | | | | |
|---------------------------|-----|----|--------------|-----|-----|-----|-----|
| 7 | 6 | 5 | 4 | 3 | 2 | 1 | 0 |
| BSY | RDY | DF | DSC /SERV | DRQ | COR | IDX | ERR |

Table 27 Alternate Status Register

This register contains the same information as the Status Register. The only difference is that reading this register does not imply interrupt acknowledge or clear a pending interrupt. See 8.11 “Status Register” on the page 55 for the definition of the bits in this register.

8.2 Command Register

This register contains the command code being sent to the device. Command execution begins immediately after this register is written. The command set is shown in Table 95 Command Set on page 134.

All other registers required for the command must be set up before writing the Command Register.

8.3 Cylinder High Register

This register contains the high order bits of the starting cylinder address for any disk access. At the end of the command, this register is updated to reflect the current cylinder number.

In LBA Mode this register contains Bits 16-23. At the end of the command, this register is updated to reflect the current LBA Bits 16-23.

The cylinder number may be from zero to the number of cylinders minus one.

When 48-bit addressing commands are used, the “most recently written” content contains LBA Bits 16-23, and the “previous content” contains Bits 40-47. The 48-bit Address feature set is described in 9.12.

8.4 Cylinder Low Register

This register contains the low order bits of the starting cylinder address for any disk access. At the end of the command, this register is updated to reflect the current cylinder number.

In LBA Mode this register contains Bits 8-15. At the end of the command, this register is updated to reflect the current LBA Bits 8-15.

The cylinder number may be from zero to the number of cylinders minus one.

When 48-bit addressing commands are used, the “most recently written” content contains LBA Bits 8-15, and the “previous content” contains Bits 32-39.

8.5 Device Control Register

| Device Control Register | | | | | | | |
|-------------------------|---|---|---|---|------|------|---|
| 7 | 6 | 5 | 4 | 3 | 2 | 1 | 0 |
| HOB | - | - | - | 1 | SRST | -IEN | 0 |

Table 28 Device Control Register

Bit Definitions

| | |
|-------------------|--|
| HOB | HOB (high order byte) is defined by the 48-bit Address feature set. A write to any Command Register shall clear the HOB bit to zero. |
| SRST (RST) | Software Reset. The device is held reset when RST=1. Setting RST=0 re-enables the device. The host must set RST=1 and wait for at least 5 microseconds before setting RST=0, to ensure that the device recognizes the reset. |
| -IEN | Interrupt Enable. When -IEN=0, and the device is selected, device interrupts to the host will be enabled. When -IEN=1, or the device is not selected, device interrupts to the host will be disabled. |

8.6 Device/Head Register

| Device/Head Register | | | | | | | |
|----------------------|---|---|-----|-----|-----|-----|-----|
| 7 | 6 | 5 | 4 | 3 | 2 | 1 | 0 |
| 1 | L | 1 | DRV | HS3 | HS2 | HS1 | HS0 |

Table 29 Device/Head Register

This register contains the device and head numbers.

Bit Definitions

| | |
|------------------------|---|
| L | Binary encoded address mode select. When L=0, addressing is by CHS mode. When L=1, addressing is by LBA mode. |
| DRV | Device. This product ignores this bit. |
| HS3,HS2,HS1,HS0 | Head Select. These four bits indicate binary encoded address of the head. HS0 is the least significant bit. At command completion, these bits are updated to reflect the currently selected head. The head number may be from zero to the number of heads minus one. In LBA mode, HS3 through HS0 contain bits 24-27 of the LBA. At command completion, these bits are updated to reflect the current LBA bits 24-27. |

8.7 Error Register

| Error Register | | | | | | | |
|----------------|-----|---|------|---|------|-------|------|
| 7 | 6 | 5 | 4 | 3 | 2 | 1 | 0 |
| ICRCE | UNC | 0 | IDNF | 0 | ABRT | TK0NF | AMNF |

Table 30 Error Register

This register contains status from the last command executed by the device, or a diagnostic code.

At the completion of any command except Execute Device Diagnostic, the contents of this register are valid always even if ERR=0 in the Status Register.

Following a power on, a reset, or completion of an Execute Device Diagnostic command, this register contains a diagnostic code. See 9.2 Diagnostic and Reset Considerations on page 57 for the definition.

Bit Definitions

| | |
|--------------------|---|
| ICRCE (CRC) | Interface CRC Error. ICRCE=1 indicates a CRC error occurred during FIS transmission or FIS reception. |
| UNC | Uncorrectable Data Error. UNC=1 indicates an uncorrectable data error has been encountered. |
| IDNF (IDN) | ID Not Found. IDN=1 indicates the requested sector's ID field could not be found. |
| ABRT (ABT) | Aborted Command. ABT=1 indicates the requested command has been aborted due to a device status error or an invalid parameter in an output register. |
| TK0NF (TON) | Track 0 Not Found. TON=1 indicates track 0 was not found during a Recalibrate command. |
| AMNF (AMN) | Address Mark Not Found. This product does not report this error. This bit is always zero. |

8.8 Features Register

This register is command specific. This is used with the Set Features command, SMART Function Set command and Format Unit command.

8.9 Sector Count Register

This register contains the number of sectors of data requested to be transferred on a read or write operation between the host and the device. If the value in the register is set to 0, a count of 256 sectors (in 28-bit addressing) or 65,536 sectors (in 48-bit addressing) is specified.

If the register is zero at command completion, the command was successful. If not successfully completed, the register contains the number of sectors which need to be transferred in order to complete the request.

The contents of the register are defined otherwise on some commands. These definitions are given in the command descriptions.

8.10 Sector Number Register

This register contains the starting sector number for any disk data access for the subsequent command. The sector number is from one to the maximum number of sectors per track.

In LBA mode, this register contains Bits 0-7. At the end of the command, this register is updated to reflect the current LBA Bits 0-7.

When 48-bit commands are used, the "most recently written" content contains LBA Bits 0-7, and the "previous content" contains Bits 24-31.

8.11 Status Register

| Status Register | | | | | | | |
|-----------------|------|----|--------------|-----|------|-----|-----|
| 7 | 6 | 5 | 4 | 3 | 2 | 1 | 0 |
| BSY | DRDY | DF | DSC /SERV | DRQ | CORR | IDX | ERR |

Table 31 Status Register

This register contains the device status. The contents of this register are updated whenever an error occurs and at the completion of each command.

If the host reads this register when an interrupt is pending, it is considered to be the interrupt acknowledge. Any pending interrupt is cleared whenever this register is read.

If BSY=1, no other bits in the register are valid.

Bit Definitions

| | |
|-------------------|---|
| BSY | Busy. BSY=1 whenever the device is accessing the registers. The host should not read or write any registers when BSY=1. If the host reads any register when BSY=1, the contents of the Status Register will be returned. |
| DRDY (RDY) | Device Ready. RDY=1 indicates that the device is capable of responding to a command. RDY will be set to 0 during power on until the device is ready to accept a command. If the device detects an error while processing a command, RDY is set to 0 until the Status Register is read by the host, at which time RDY is set back to 1. |
| DF | Device Fault. This product does not support DF bit. DF bit is always zero. |
| DSC | Device Seek Complete. DSC=1 indicates that a seek has completed and the device head is settled over a track. DSC is set to 0 by the device just before a seek begins. When an error occurs, this bit is not changed until the Status Register is read by the host, at which time the bit again indicates the current seek complete status. When the device enters into or is in Standby mode or Sleep mode, this bit is set by device in spite of not spinning up. |
| SERV (SRV) | Service. This product does not support SERV bit. |
| DRQ | Data Request. DRQ=1 indicates that the device is ready to transfer a word or byte of data between the host and the device. The host should not write the Command register when DRQ=1. |
| CORR (COR) | Corrected Data. Always 0. |
| IDX | Index. IDX=1 once per revolution. Since IDX=1 only for a very short time during each revolution, the host may not see it set to 1 even if the host is reading the Status Register continuously. Therefore, the host should not attempt to use IDX for timing purposes. |
| ERR | Error. ERR=1 indicates that an error occurred during execution of the previous command. The Error Register should be read to determine the error type. The device sets ERR=0 when the next command is received from the host. |

9 General Operation Descriptions

9.1 Reset Response

There are three types of reset in ATA as follows:

- Power On Reset (POR)** The device executes a series of electrical circuitry diagnostics.
- COMRESET** COMRESET is issued in Serial ATA bus.
The device resets the interface circuitry as well as Soft Reset.
- Soft Reset (Software Reset)** SRST bit in the Device Control Register is set, and then is reset.
The device resets the interface circuitry according to the Set Features requirement.

The actions of each reset are shown in Table 32.

| | POR | COMRESET | Soft Reset |
|---|------|----------|------------|
| Aborting Host interface | - | o | o |
| Aborting Device operation | - | (*1) | (*1) |
| Initialization of hardware | o | x | x |
| Internal diagnostic | o | x | x |
| Spinning spindle | (*6) | x | x |
| Initialization of registers (*2) | o | o | o |
| Reverting programmed parameters to default - Number of CHS (set by Initialize Device Parameter) - Multiple mode - Write cache - Read look-ahead - ECC bytes | o | (*3) | (*3) |
| Disable Standby timer | o | x | x |
| Power mode | (*5) | (*4) | (*4) |

o-----Execute
x----- Not execute

Table 32 Reset Response

Table Notes

- (*1) Execute after the data in write cache has been written.
- (*2) Default value on POR is shown in Table 34 Default Register Values on page 57.
- (*3) The Set Features command with Feature register = CCh enables the device to revert these parameters to the power on defaults.
- (*4) In the case of Sleep mode, the device goes to Standby mode. In other case, the device does not change current mode.
- (*5) Idle when Power-Up in Standby feature set is disabled. Standby when Power-Up in Standby feature set is enabled.
- (*6) Spinning up when Power-Up in Standby feature set is disabled. Standby when Power-Up in Standby feature set is enabled.

9.1.1 Register Initialization

| Register | Default Value |
|------------------|-----------------|
| Error | Diagnostic Code |
| Sector Count | 01h |
| Sector Number | 01h |
| Cylinder Low | 00h |
| Cylinder High | 00h |
| Device/Head | 00h |
| Status | 50h |
| Alternate Status | 50h |

Table 33 Default Register Values

After power on, hard reset, or software reset, the register values are initialized as shown in Table 33.

| Code | Description |
|------|---------------------------------|
| 01h | No error Detected |
| 02h | Formatter device error |
| 03h | Sector buffer error |
| 04h | ECC circuitry error |
| 05h | Controller microprocessor error |

Table 34 Diagnostic Codes

The meaning of the Error Register diagnostic codes resulting from power on, hard reset or the Execute Device Diagnostic command is shown in Table 34.

9.2 Diagnostic and Reset Considerations

In each case of Power on Reset, COMRESET, Soft reset, and EXECUTE DEVICE DIAGNOSTIC command, the device is diagnosed. An Error register is set as shown in Table 34.

9.3 Sector Addressing Mode

All addressing of data sectors recorded on the device's media is by a logical sector address. The logical CHS address for HUS726TxTALx6xx is different from the actual physical CHS location of the data sector on the disk media. All addressing of data sectors recorded on the device's media.

HUS726TxTALx6xx support both Logical CHS Addressing Mode and LBA Addressing Mode as the sector addressing mode.

The host system may select either the currently selected CHS translation addressing or LBA addressing on a command-by-command basis by using the L bit in the DEVICE/HEAD register. So, a host system must set the L bit to 1 if the host uses LBA Addressing mode.

9.3.1 Logical CHS Addressing Mode

The logical CHS addressing is made up of three fields: the cylinder number, the head number and the sector number. Sectors are numbered from 1 to the maximum value allowed by the current CHS translation mode but cannot exceed 255(0FFh). Heads are numbered from 0 to the maximum value allowed by the current CHS translation mode but cannot exceed 15(0Fh). Cylinders are numbered from 0 to the maximum value allowed by the current CHS translation mode but cannot exceed 65535(0FFFFh).

When the host selects a CHS translation mode using the INITIALIZE DEVICE PARAMETERS command, the host requests the number of sectors per logical track and the number of heads per logical cylinder. The device then computes the number of logical cylinders available in requested mode.

The default CHS translation mode is described in the Identify Device Information. The current CHS translation mode also is described in the Identify Device Information.

9.3.2 LBA Addressing Mode

Logical sectors on the device shall be linearly mapped with the first LBA addressed sector (sector 0) being the same sector as the first logical CHS addressed sector (cylinder 0, head 0, sector 1). Irrespective of the logical CHS translation mode currently in effect, the LBA address of a given logical sector does not change. The following is always true:

$$\text{LBA} = ((\text{cylinder} * \text{heads_per_cylinder} + \text{heads}) * \text{sectors_per_track}) + \text{sector} - 1$$

Where heads_per_cylinder and sectors_per_track are the current translation mode values.

On LBA addressing mode, the LBA value is set to the following register.

| | | | |
|---------------|---|-----|------------|
| Device/Head | ← | LBA | 27-24 bits |
| Cylinder High | ← | LBA | 23-16 bits |
| Cylinder Low | ← | LBA | 15- 8 bits |
| Sector Number | ← | LBA | 7- 0 bits |

9.4 Power Management Feature

The power management feature set allows an application client to modify the behavior of a device in a manner that reduces the power required to operate. The power management feature set provides a set of commands and a timer that enables a device to implement low power consumption modes.

The Power Management feature set implements the following set of functions.

1. A Standby timer
2. Idle command
3. Idle Immediate command
4. Sleep command
5. Standby command
6. Standby Immediate command

9.4.1 Power Mode

The lowest power consumption when the device is powered on occurs in Sleep Mode. When in sleep mode, the device requires a reset to be activated.

In Idle Mode the device is capable of responding immediately to media access requests.

In Active Mode the device is under executing a command or accessing the disk media with read look-ahead function or writes cache function.

9.4.1.1 Active Idle Mode

The electronics repeats on and off. And heads are track following and seeking, however the spindle is still rotated at the full speed.

9.4.1.2 Low Power Idle Mode

Additional electronics are powered off, and heads are unloaded on the ramp, however the spindle is still rotated at the full speed.

9.4.1.3 Low RPM Idle Mode

The heads are unloaded on the ramp, and the spindle is rotated at the 85-90% of the full speed.

9.4.1.4 Standby Mode

The device interface is capable of accepting commands, but as the media may not immediately accessible, there is a delay while waiting for the spindle to reach operating speed.

9.4.2 Power Management Commands

The Check Power Mode command allows a host to determine if a device is in, going, to or leaving standby or idle mode.

The Idle and Idle Immediate commands move a device to idle mode immediately from the active or standby modes. The idle command also sets the standby timer count and enables or disables the standby timer.

The Standby and Standby Immediate commands move a device to standby mode immediately from the active or idle modes. The standby command also sets the standby timer count and enables or disables the Standby timer.

The Sleep command moves a device to sleep mode. The device's interface becomes inactive after the device reports command completion for the sleep command. A device only transitions from sleep mode after processing hardware reset, a software reset.

9.4.3 Standby Timer

The standby timer provides a method for the device to automatically enter standby mode from either active or idle mode following a host programmed period of inactivity. If the device is in the active or idle mode, the device waits for the specified time period and if no command is received, the device automatically enters the standby mode.

If the value of SECTOR COUNT Register on Idle command or Standby command is set to 00h, the standby timer is disabled.

9.4.4 Interface Capability for Power Modes

Each power mode affects the physical interface as defined in the following table:

| Mode | BSY | RDY | Interface active | Media |
|---------|-----|-----|------------------|----------|
| Active | x | x | Yes | Active |
| Idle | 0 | 1 | Yes | Active |
| Standby | 0 | 1 | Yes | Inactive |
| sleep | x | x | No | Inactive |

Table 35 Power Conditions

Ready (RDY) is not a power condition. A device may post ready at the interface even though the media may not be accessible.

9.5 SMART Function

The intent of Self-monitoring, analysis and reporting technology (SMART) is to protect user data and prevent unscheduled system downtime that may be caused by predictable degradation and/or fault of the device. By monitoring and storing critical performance and calibration parameters, SMART devices employ sophisticated data analysis algorithms to predict the likelihood of near-term degradation or fault condition. By alerting the host system of a negative reliability status condition, the host system can warn the user of the impending risk of a data loss and advise the user of appropriate action.

9.5.1 Attributes

Attributes are the specific performance or calibration parameters that are used in analyzing the status of the device. Attributes are selected by the device manufacturer based on that attribute's ability to contribute to the prediction of degrading or faulty conditions for that particular device. The specific set of attributes being used and the identity of these attributes is vendor specific and proprietary.

9.5.2 Attribute Values

Attribute values are used to represent the relative reliability of individual performance or calibration attributes. The valid range of attribute values is from 1 to 253 decimal. Higher attribute values indicate that the analysis algorithms being used by the device are predicting a lower probability of a degrading or faulty condition existing. Accordingly, lower attribute values indicate that the analysis algorithms being used by the device are predicting a higher probability of a degrading or faulty condition existing.

9.5.3 Attribute Thresholds

Each attribute value has a corresponding attribute threshold limit which is used for direct comparison to the attribute value to indicate the existence of a degrading or faulty condition. The numerical values of the attribute thresholds are determined by the device manufacturer through design and reliability testing and analysis. Each attribute threshold represents the lowest limit to which its corresponding attribute value can be equal while still retaining a positive reliability status. Attribute thresholds are set at the device manufacturer's factory and cannot be changed in the field. The valid range for attribute thresholds is from 1 through 253 decimal.

9.5.4 Threshold Exceeded Condition

If one or more attribute values, whose Pre-failure bit of their status flag is set, are less than or equal to their corresponding attribute thresholds, then the device reliability status is negative, indicating an impending degrading or faulty condition.

9.5.5 SMART Commands

The SMART commands provide access to attribute values, attribute thresholds and other logging and reporting information.

9.5.6 Off-Line Read Scanning

The device provides the off-line read scanning feature with reallocation. This is the extension of the off-line data collection capability. The device performs the entire read scan with reallocation for the marginal sectors to prevent the user data lost.

If interrupted by the host during the read scanning, the device services the host command.

9.5.7 Error Log

Logging of reported errors is supported. The device provides information on the last five errors that the device reported as described in SMART error log sector. The device may also provide additional vendor specific information on these reported errors. The error log is not disabled when SMART is disabled. Disabling SMART shall disable the delivering of error log information via the SMART READ LOG SECTOR command.

If a device receives a firmware modification, all error log data is discarded and the device error count for the life of the device is reset to zero.

9.5.8 Self-Test

The device provides the self-test features which are initiated by SMART Execute Off-line Immediate command. The self-test checks the fault of the device, reports the test status in Device Attributes Data and stores the test result in the SMART self-test log sector as described in SMART self-test log data structure. All SMART attributes are updated accordingly during the execution of self-test.

If interrupted by the host during the self-tests, the device services the host command.

If the device receives a firmware modification, all self-test log data is discarded.

9.6 Security Mode Feature Set

Security Mode Feature Set is a powerful security feature. With a device lock password, a user can prevent unauthorized access to hard disk device even if the device is removed from the computer.

The following commands are supported for this feature.

| | |
|----------------------------------|---------|
| Security Set Password | (‘F1’h) |
| Security Unlock | (‘F2’h) |
| Security Erase Prepare | (‘F3’h) |
| Security Erase Unit | (‘F4’h) |
| Security Freeze Lock | (‘F5’h) |
| Security Disable Password | (‘F6’h) |

Execution of these commands is restricted for the Trusted Computing Group feature set. That is, these commands operate only in the state that is the Manufactured-Inactivate state by the Trusted Computing Group feature set. Moreover, these commands are aborted in the state that is activated to the Manufactured state by the Trusted Computing Group feature set.

9.6.1 Security Mode

Following security modes are provided.

| | |
|-----------------------------|--|
| Device Locked mode | The device disables media access commands after power on. Media accesses commands are enabled by either a security unlock command or a security erases unit command. |
| Device Unlocked mode | The device enables all commands. If a password is not set this mode is entered after power on, otherwise it is entered by a security unlock or a security erases unit command. |
| Device Frozen mode | The device enables all commands except those which can update the device lock function, set/change password. The device enters this mode via a Security Freeze Lock command. It cannot quit this mode until power off. |

9.6.2 Security Level

Following security levels are provided.

| | |
|-------------------------------|---|
| High level security | When the device lock function is enabled and the User Password is forgotten the device can be unlocked via a Master Password. |
| Maximum level security | When the device lock function is enabled and the User Password is forgotten then only the Master Password with a Security Erase Unit command can unlock the device. Then user data is erased. |

9.6.3 Password

This function can have 2 types of passwords as described below.

| | |
|------------------------|---|
| Master Password | When the Master Password is set, the device does NOT enable the Device Lock Function, and the device can NOT be locked with the Master Password, but the Master Password can be used for unlocking the device locked. Identify Device Information word 92 contains the value of the Master Password Revision Code set when the Master Password was last changed. Valid values are 0001h through FFFEh. |
| User Password | The User Password should be given or changed by a system user. When the User Password is set, the device enables the Device Lock Function, and then the device is locked on next power on reset or hard reset. |

The system manufacturer/dealer who intends to enable the device lock function for the end users, must set the master password even if only single level password protection is required.

9.6.4 Operation Example

9.6.4.1 Master Password Setting

The system manufacturer/dealer can set a new Master Password from default Master Password using the 2 Set Password command, without enabling the Device Lock Function.

The Master Password Revision Code is set to FFFEh as shipping default by the HDD manufacturer

9.6.4.2 User Password Setting

When a User Password is set, the device will automatically enter lock mode the next time the device is powered on.

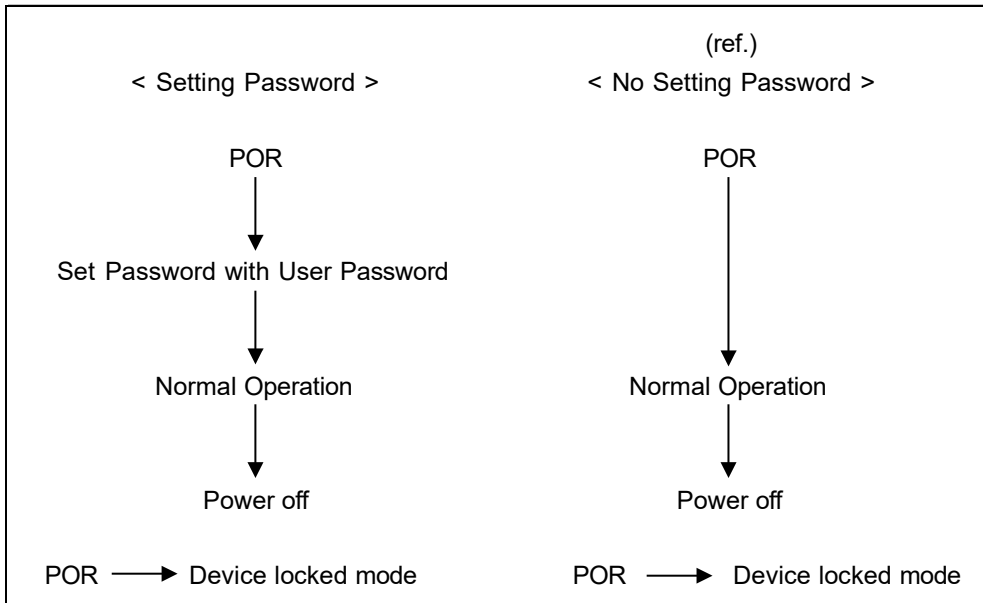
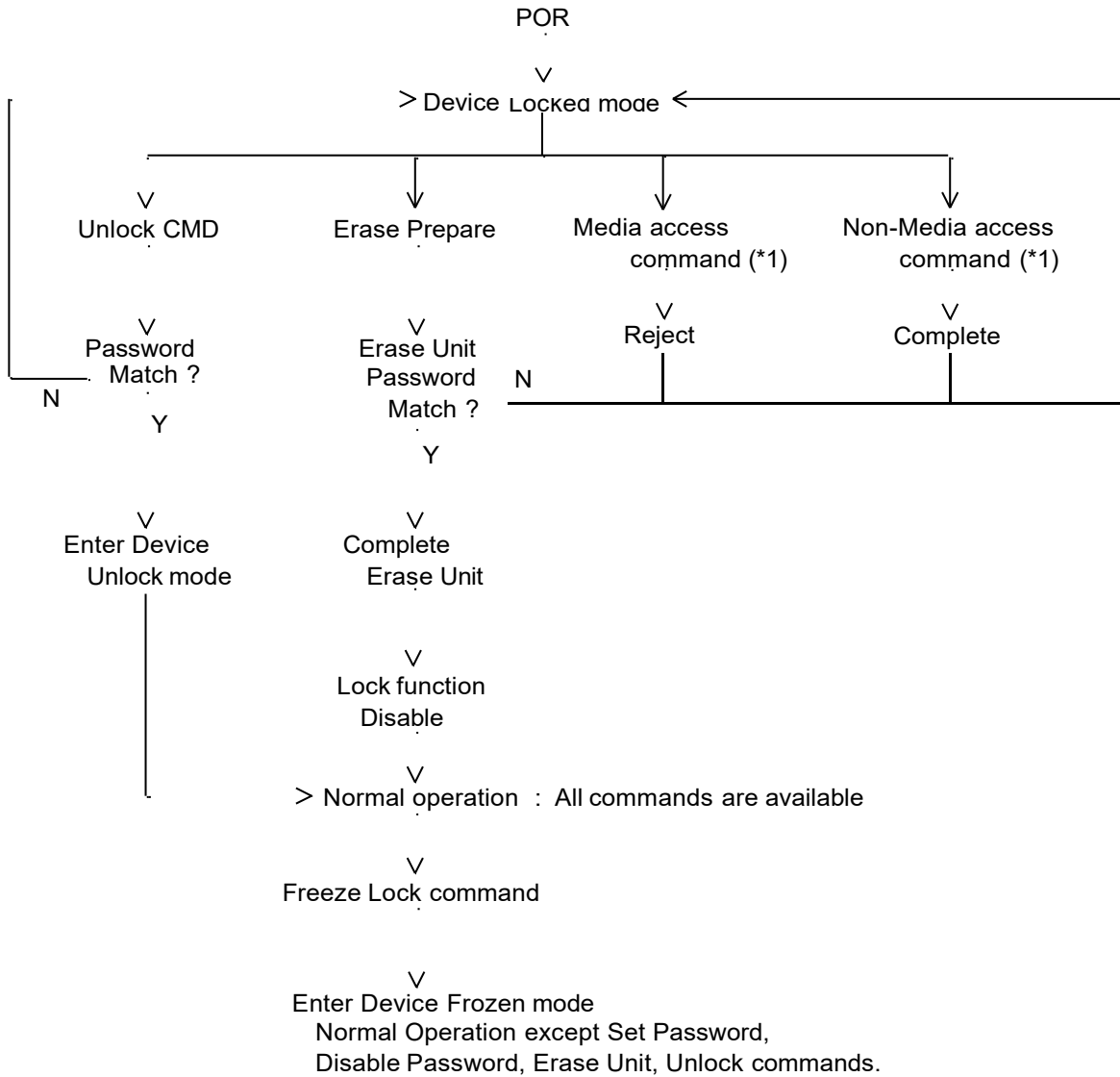

Figure 11 Initial Setting

9.6.4.3 Operation from POR After User Password is Set

When Device Lock Function is enabled, the device rejects media access command until a Security Unlock command is successfully completed.



(*1) Refer to 9.6.5 on the page.67

Figure 12 Usual Operation

9.6.4.4 User Password Lost

If the User Password is forgotten and High level security is set, the system user can't access any data. However, the device can be unlocked using the Master Password.

If a system user forgets the User Password and Maximum security level is set, data access is impossible. However, the device can be unlocked using the Security Erase Unit command to unlock the device and erase all user data with the Master Password.

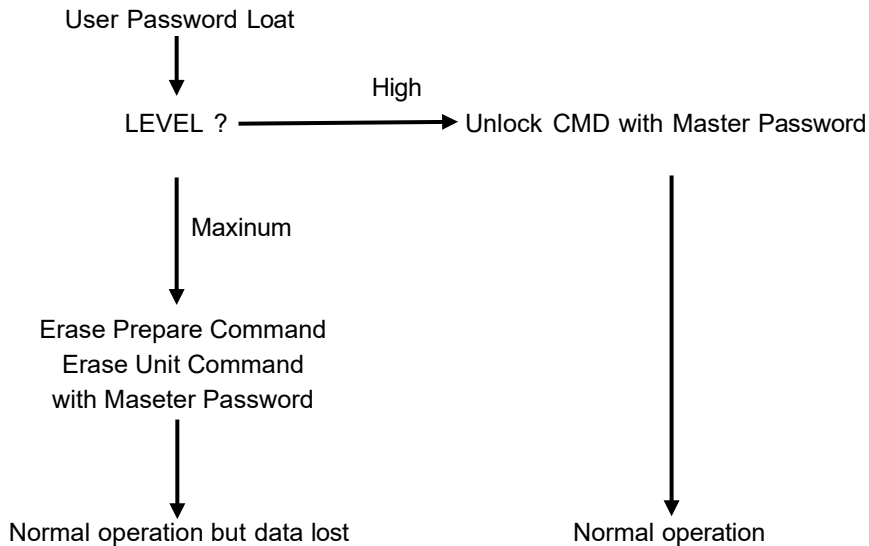

Figure 13 Password Lost

9.6.4.5 Attempt Limit for SECURITY UNLOCK Command

The SECURITY UNLOCK command has an attempt limit. The purpose of this attempt limit is to prevent that someone attempts to unlock the drive by using various passwords many times.

The device counts the password mismatch. If the password does not match, the device counts it up without distinguishing the Master password and the User password. If the count reaches 5, EXPIRE bit (bit 4) of Word 128 in Identify Device information is set, and then SECURITY ERASE UNIT command and SECURITY UNLOCK command are aborted until a hard reset or a power off. The count and EXPIRE bit are cleared after a power on reset or a hard reset.

9.6.5 Command Table

This table shows the device's response to commands when the Security Mode Feature Set (Device lock function) is enabled.

| Command | Locked Mode | Unlocked Mode | Frozen Mode |
|----------------------------------|-----------------|---------------|-------------|
| Check Power Mode | Executable | Executable | Executable |
| Configure Stream | Command aborted | Executable | Executable |
| Crypto Scramble Ext | Command aborted | Executable | Executable |
| Device Configuration Restore | Command aborted | Executable | Executable |
| Device Configuration Freeze Lock | Command aborted | Executable | Executable |
| Device Configuration Identify | Command aborted | Executable | Executable |
| Device Configuration Set | Command aborted | Executable | Executable |
| Download Microcode | Command aborted | Executable | Executable |
| Download Microcode DMA | Command aborted | Executable | Executable |
| Execute Device Diagnostic | Executable | Executable | Executable |
| Flush Cache | Command aborted | Executable | Executable |
| Flush Cache Ext | Command aborted | Executable | Executable |
| Format Track | Command aborted | Executable | Executable |
| Identify Device | Executable | Executable | Executable |
| Idle | Executable | Executable | Executable |
| Idle Immediate | Executable | Executable | Executable |
| Initialize Device Parameters | Executable | Executable | Executable |
| NCQ NON-DATA | Command aborted | Executable | Executable |
| Overwrite Ext | Command aborted | Executable | Executable |
| Read Buffer | Executable | Executable | Executable |
| Read DMA | Command aborted | Executable | Executable |
| Read DMA Ext | Command aborted | Executable | Executable |
| Read FPDMA Queued | Command aborted | Executable | Executable |
| Read Log Ext | Executable | Executable | Executable |
| Read Log DMA Ext | Executable | Executable | Executable |
| Read Multiple | Command aborted | Executable | Executable |
| Read Multiple Ext | Command aborted | Executable | Executable |
| Read Native Max Address | Executable | Executable | Executable |
| Read Native Max Ext | Executable | Executable | Executable |
| Read Sector(s) | Command aborted | Executable | Executable |
| Read Sector(s) Ext | Command aborted | Executable | Executable |
| Read Stream DMA Ext | Command aborted | Executable | Executable |
| Read Stream Ext | Command aborted | Executable | Executable |
| Read Verify Sector(s) | Command aborted | Executable | Executable |
| Read Verify Sector(s) Ext | Command aborted | Executable | Executable |
| Recalibrate | Executable | Executable | Executable |
| Request Sense Data Ext | Executable | Executable | Executable |
| Sanitize Freeze Lock Ext | Command aborted | Executable | Executable |
| Sanitize Status Ext | Executable | Executable | Executable |

Table 36 Command Table for Device Lock Operation -1

| Command | Locked Mode | Unlocked Mode | Frozen Mode |
|---|-----------------|-----------------|-----------------|
| SCT Read/Write Long | Command aborted | Command aborted | Command aborted |
| SCT Write Same | Command aborted | Executable | Executable |
| SCT Error Recovery Control | Command aborted | Executable | Executable |
| SCT Feature Control | Command aborted | Executable | Executable |
| SCT Data Table | Command aborted | Executable | Executable |
| SCT Read Status | Executable | Executable | Executable |
| Security Disable Password | Command aborted | Executable | Command aborted |
| Security Erase Prepare | Executable | Executable | Command aborted |
| Security Erase Unit | Executable | Executable | Command aborted |
| Security Freeze Lock | Command aborted | Executable | Executable |
| Security Set Password | Command aborted | Executable | Command aborted |
| Security Unlock | Executable | Executable | Command aborted |
| Seek | Executable | Executable | Executable |
| Set Features | Executable | Executable | Executable |
| Set Max Address | Command aborted | Executable | Executable |
| Set Max Address Ext | Command aborted | Executable | Executable |
| Set Multiple Mode | Executable | Executable | Executable |
| Set Sector Configuration Ext | Command aborted | Executable | Executable |
| Sleep | Executable | Executable | Executable |
| SMART Disable Operations | Executable | Executable | Executable |
| SMART Enable/Disable Attribute Autosave | Executable | Executable | Executable |
| SMART Enable Operations | Executable | Executable | Executable |
| SMART Execute Off-line Immediate | Executable | Executable | Executable |
| SMART Read Attribute Values | Executable | Executable | Executable |
| SMART Read Attribute Thresholds | Executable | Executable | Executable |
| SMART Return Status | Executable | Executable | Executable |
| SMART Save Attribute Values | Executable | Executable | Executable |
| SMART Read Log Sector | Executable | Executable | Executable |
| SMART Write Log Sector | Executable | Executable | Executable |
| SMART Enable/Disable Automatic Off-Line | Executable | Executable | Executable |
| Standby | Executable | Executable | Executable |
| Standby Immediate | Executable | Executable | Executable |
| Trusted Receive | Command aborted | Executable | Executable |
| Trusted Receive DMA | Command aborted | Executable | Executable |
| Trusted Send | Command aborted | Executable | Executable |
| Trusted Send DMA | Command aborted | Executable | Executable |
| Write Buffer | Executable | Executable | Executable |
| Write DMA | Command aborted | Executable | Executable |
| Write DMA Ext | Command aborted | Executable | Executable |

Table 37 Command Table for Device Lock Operation -2

| Command | Locked Mode | Unlocked Mode | Frozen Mode |
|-------------------------|--------------------|----------------------|--------------------|
| Write DMA FUA Ext | Command aborted | Executable | Executable |
| Write FPDMA Queued | Command aborted | Executable | Executable |
| Write Log Ext | Command aborted | Executable | Executable |
| Write Log DMA Ext | Command aborted | Executable | Executable |
| Write Multiple | Command aborted | Executable | Executable |
| Write Multiple Ext | Command aborted | Executable | Executable |
| Write Multiple FUA Ext | Command aborted | Executable | Executable |
| Write Sector(s) | Command aborted | Executable | Executable |
| Write Sector(s) Ext | Command aborted | Executable | Executable |
| Write Stream DMA Ext | Command aborted | Executable | Executable |
| Write Stream Ext | Command aborted | Executable | Executable |
| Write Uncorrectable Ext | Command aborted | Executable | Executable |

Table 38 Command Table for Device Lock Operation -3

9.7 Host Protected Area Feature

Host Protected Area Feature is to provide the 'protected area' which cannot be accessed via conventional method. This 'protected area' is used to contain critical system data such as BIOS or system management information. The contents of entire system main memory may also be dumped into 'protected area' to resume after system power off. The LBA/CYL changed by following command affects the Identify Device Information.

The following set of commands is implemented for this function.

Read Native Max ADDRESS ('F8'h)
Set Max ADDRESS ('F9'h)

9.7.1 Example for Operation (in LBA mode)

Assumptions:

For better understanding, the following example uses actual values for LBA, size, etc. Since it is just an example, these values could be different.

Device characteristics

| | | | |
|------------------------------------|---|--------------------|--------------|
| Capacity (native) | : | 6,498,680,832 | byte (6.4GB) |
| Max LBA (native) | : | 12,692,735 | (0FFFFFFh) |
| Required size for protected area | : | 206,438,400 | byte |
| Required blocks for protected area | : | 403,200 | (062700h) |
| Customer usable device size | : | 6,292,242,432 | byte (6.2GB) |
| Customer usable sector count | : | 12,289,536 | (BB8600h) |
| LBA range for protected area | : | BB8600h to C1ACFFh | |

1. Shipping HDDs from HDD manufacturer

When the HDDs are shipped from HDD manufacturer, the device has been tested to have usable capacity of 6.4GB besides flagged media defects not to be visible by system.

2. Preparing HDDs at system manufacturer

Special utility software is required to define the size of protected area and store the data into it. The sequence is:

Issue Read Native Max Address command to get the real device maximum LBA. Returned value shows that native device Maximum LBA is 12,692,735 (C1ACFFh) regardless of the current setting.

Make entire device be accessible including the protected area by setting device Maximum LBA as 12,692,735 (C1ACFFh) via Set Max Address command. The option could be either nonvolatile or volatile.

Test the sectors for protected area (LBA >= 12,289,536 (BB8600h)) if required.

Write information data such as BIOS code within the protected area.

Change maximum LBA using Set Max Address command to 12,289,535 (BB85FFh) with nonvolatile option.

From this point, the protected area cannot be accessed till next Set Max Address command is issued. Any BIOSes, device drivers, or application software access the HDD as if that is the 6.2GB device because the device acts exactly the same as real 6.2GB device does.

3. Conventional usage without system software support

Since the HDD works as 6.2GB device, there is no special care to use this device for normal use.

4. Advanced usage using protected area

The data in the protected area is accessed by following.

Issue Read Native Max Address command to get the real device maximum LBA. Returned value shows that native device Maximum LBA is 12,692,735 (C1ACFFh) regardless of the current setting.

Make entire device be accessible including the protected area by setting device Maximum LBA as 12,692,735 (C1ACFFh) via Set Max Address command with volatile option. By using this option, unexpected power removal or reset will not make the protected area remained accessible.

Read information data from protected area.

Issue hard reset or POR to inhibit any access to the protected area.

9.7.2 Security Extensions

1. Set Max Set Password
2. Set Max Lock
3. Set Max Freeze Lock
4. Set Max Unlock.

The Set Max Set Password command allows the host to define the password to be used during the current power on cycle. The password does not persist over a power cycle but does persist over a hardware or software reset. This password is not related to the password used for the Security Mode Feature set. When the password is set the device is in the Set_Max_Unlocked mode. The Set Max Lock command allows the host to disable the Set Max commands (except set Max Unlock) until the next power cycle or the issuance and acceptance of the Set Max Unlock command. When this command is accepted the device is in the Set_Max_Locked mode. The Set Max Unlock command changes the device from the Set_Max_Locked mode to the Set_Max_Unlocked mode. The Set Max Freeze Lock command allows the host to disable the Set Max commands (including Set Max UNLOCK) until the next power cycle. When this command is accepted the device is in the Set_Max_Frozen mode.

The IDENTIFY DEVICE response word 83, bit 8 indicates that this extension is supported if set, and word 86, bit 8 indicate the Set Max security extension enabled if set.

9.8 Write Cache Function

Write cache is a performance enhancement whereby the device reports as completing the write command (Write Sector(s), Write Multiple and Write DMA) to the host as soon as the device has received all of the data into its buffer. And the device assumes responsibility to write the data subsequently onto the disk.

- While writing data after completed acknowledgment of a write command, soft reset or hard reset does not affect its operation. But power off terminates writing operation immediately and unwritten data are to be lost.
- Soft reset, Standby (Immediate) command and Flush Cache commands during writing the cached data are executed after the completion of writing to media. So the host system can confirm the completion of write cache operation by issuing Soft reset, Standby (Immediate) command or Flush Cache command to the device before power off.

9.9 Reassign Function

The reassign Function is used with read commands and write commands. The sectors of data for reassignment are prepared as the spare data sector.

This reassignment information is registered internally, and the information is available right after completing the reassign function. Also the information is used on the next power on reset or hard reset.

If the number of the spare sector reaches 0 sectors, the reassign function will be disabled automatically.

The spare tracks for reassignment are located at regular intervals from Cylinder 0. As a result of reassignment, the physical location of logically sequenced sectors will be dispersed.

9.9.1 Auto Reassign Function

The sectors those show some errors may be reallocated automatically when specific conditions are met. The spare tracks for reallocation are located at regular intervals from Cylinder 0. The conditions for auto-reallocation are described below.

None recovered write errors

When a write operation cannot be completed after the Error Recovery Procedure (ERP) is fully carried out, the sector(s) are reallocated to the spare location. An error is reported to the host system only when the write cache is disabled and the auto reallocation is failed.

If the write cache function is ENABLED, and when the number of available spare sectors reaches 0 sectors, both auto reassign function and write cache function are disabled automatically.

None recovered read errors

When a read operation is failed after defined ERP is fully carried out, a hard error is reported to the host system. This location is registered internally as a candidate for the reallocation. When a registered location is specified as a target of a write operation, a sequence of media verification is performed automatically. When the result of this verification meets the criteria, this sector is reallocated.

Recovered read errors

When a read operation for a sector failed once then recovered at the specific ERP step, this sector of data is reallocated automatically. A media verification sequence may be run prior to the relocation according to the pre-defined conditions.

9.10 Power-Up in Standby Feature Set

Power-Up In Standby feature set allows devices to be powered-up into the Standby power management state to minimize inrush current at power-up and to allow the host to sequence the spin-up of devices.

This feature set will be enabled/disabled via the SET FEATURES command. The enabling of this feature set shall be persistent after power cycle.

A device needs a SET FEATURES subcommand to spin-up to active state when the device has powered-up into Standby. The device remains in Standby until the SET FEATURES subcommand is received.

If power-up into Standby is enabled, when an IDENTIFY DEVICE is received while the device is in Standby as a result of powering up into Standby, the device shall set word 0 bit 2 to one to indicate that the response is incomplete, then only words 0 and 2 are correctly reported.

The IDENTIFY DEVICE information indicates the states as follows:

- identify device information is complete or incomplete
- this feature set is implemented
- this feature set is enabled or disabled
- the device needs the Set Features command to spin-up into active state

9.11 Advanced Power Management Feature Set (APM)

This feature allows the host to select an advanced power management level. The advanced power management level is a scale from the lowest power consumption setting of 01h to the maximum performance level of FEh. Device performance may increase with increasing advanced power management levels. Device power consumption may increase with increasing advanced power management levels. The advanced power management levels contain discrete bands, described in the section of Set Feature command in detail. This feature set uses the following functions:

1. A SET FEATURES subcommand to enable Advanced Power Management
2. A SET FEATURES subcommand to disable Advanced Power Management

Advanced Power Management is independent of the Standby timer setting. If both Advanced Power Management and the Standby timer are set, the device will go to the Standby state when the timer times out or the device's Advanced Power Management algorithm indicates that the Standby state should be entered.

The IDENTIFY DEVICE response word 83, bit 3 indicates that Advanced Power Management feature is supported if set. Word 86, bit 3 indicates that Advanced Power Management is enabled if set. Word 91, bits 7-0 contain the current Advanced Power Management level if Advanced Power Management is enabled.

9.12 48-bit Address Feature Set

The 48-bit Address feature set allows devices:

- a) with capacities up to 281,474,976,710,655 logical sectors (i.e., up to 144,115,188,075,855,360 bytes for a 512-byte logical block device); and
- b) to transfer up to 65 536 logical sectors in a single command.

The 48-bit Address feature set operates in LBA addressing only. Devices also implement commands using 28-bit addressing, and 28-bit and 48-bit commands may be intermixed.

Support of the 48-bit Address feature set is indicated in the Identify Device response bit 10 words 83. In addition, the maximum user LBA address accessible by 48-bit addressable commands is contained in Identify Device response words 230 through 233.

When the 48-bit Address feature set is implemented, the native maximum address is the value returned by a Read Native Max Address Ext command. If the native maximum address is equal to or less than 268,435,455, a Read Native Max Address shall return the native maximum address. If the native maximum address is greater than 268,435,455, a Read Native Max Address shall return a value of 268,435,455.

9.13 Streaming Feature Set

The Streaming feature set is an optional feature set that allows a host to request delivery of data from a contiguous logical block address range within an allotted time. This places a priority on time to access the data rather than the integrity of the data. Streaming feature set commands only support 48-bit addressing.

A device that implements the Streaming feature set shall implement the following minimum set of commands:

- Configure Stream
- Read Stream Ext
- Write Stream Ext
- Read Stream DMA Ext
- Write Stream DMA Ext
- Read Log Ext

Support of the Streaming feature set is indicated in Identify Device work 84 bit 4.

Note that PIO versions of these commands limit the transfer rate (16.6 MB/s), provide no CRC protection, and limit status reporting as compared to a DMA implementation.

9.13.1 Streaming Commands

The streaming commands are defined to be time critical data transfers rather than the standard data integrity critical commands. Each command shall be completed within the time specified in the Configure Stream command or in the streaming command itself in order to ensure the stream requirements of the AV type application. The device may execute background tasks as long as the Read Stream and Write Stream command execution time limits are still met.

Using the Configure Stream command, the host may define the various stream properties including the default Command Completion Time Limit (CCTL) to assist the device in setting up its caching for best performance. If the host does not use a Configure Stream command, the device shall use the CCTL specified in each streaming command, and the time limit is effective for one time only. If the CCTL is not set by Configure Stream command, the operation of a streaming command with a zero CCTL is device vendor specific. If Stream ID is not set by a Configure Stream command, the device shall operate according to the Stream ID set by the streaming command. The operation is device vendor specific.

The streaming commands may access any user LBA on a device. These commands may be interspersed with non-streaming commands, but there may be an impact on performance due to the unknown time required to complete the non-streaming commands.

The streaming commands should be issued using a specified minimum number of sectors transferred per command, as specified in word 95 of the Identify Device response. The transfer length of a request should be a multiple of the minimum number of sectors per transfer.

The host provided numeric stream identifier, Stream ID, may be used by the device to configure its resources to support the streaming requirements of the AV content. One Stream ID may be configured for each read and write operation with different command completion time limits by each Configure Stream command.

9.13.1.1 Urgent Bit

The Urgent bit in the Read Stream and Write Stream commands specifies that the command should be completed in the minimum possible time by the device and shall be completed within the specified Command Completion Time Limit.

9.13.1.2 Flush to Disk Bit

The Flush to Disk bit in the Write Stream command specifies that all data for the specified stream shall be flushed to the media before posting command completion. If a host requests flushes at times other than the end of each Allocation Unit, streaming performance may be degraded. The Set Features command to enable/disable caching shall not affect caching for streaming commands.

9.13.1.3 Not Sequential Bit

The Not Sequential bit specifies that the next read stream command with the same Stream ID may not be sequential in LBA space. This information helps the device with pre-fetching decisions.

9.13.1.4 Read Continuous Bit

If the Read Continuous bit is set to one for the command, the device shall transfer the requested amount of data to the host within the Command Completion Time Limit even if an error occurs. The data sent to the host by the device in an error condition is vendor specific.

9.13.1.5 Write Continuous Bit

If the Write Continuous bit is set to one for the command, and an error is encountered, the device shall complete the request without posting an error. If an error cannot be resolved within the Command Completion Time Limit, the erroneous section on the media may be unchanged or may contain undefined data. A future read of this area may not report an error, even though the data is erroneous.

9.13.1.6 Handle Streaming Error Bit

The Handle Streaming Error bit specifies to the device that this command starts at the LBA of a recently reported error section, so the device may attempt to continue its corresponding error recovery sequence where it left off earlier. This mechanism allows the host to schedule error recovery and defect management for content critical data.

9.14 SATA BIST (built-in self-test)

The device supports the following BIST modes, and begins operations when it receives BIST Activate FIS.

F – Far End Analog Loopback.

L – Far End Retimed Loopback

T – Far End Transmit only

A – ALIGN Bypass (valid only in combination with T bit)

S – Bypass Scrambling (valid only in combination with T bit)

9.15 SATA Interface Power Management

The device supports both receiving host-initiated interface power management requests and initiating interface power management. The device initiates interface power management when the device enters its power saving mode whose power consumption is lower than Idle mode.

9.15.1 Low PHY Power Conditions Overview

Low PHY power conditions are PHY conditions where the PHY is in a reduced power state (e.g., has disabled circuitry in order to reduce power). This document defines the amount of power consumed in that low PHY power condition. The low PHY power conditions include the partial PHY power condition and the slumber PHY power condition (see section **Error! Reference source not found.**).

If the partial PHY power condition is enabled and the received IDENTIFY data indicates PARTIAL mode capability, then the PHY may generate PMREQ_P (PARTIAL) primitive sequences.

If the slumber PHY power condition is enabled and the received IDENTIFY data indicates SLUMBER mode capability, then the PHY may generate PMREQ_S (SLUMBER) primitive sequences.

If low PHY power conditions are enabled, then the PHY may reply with a PMACK primitive sequence to accept a low PHY power condition request.

If low PHY power conditions are supported and disabled, then the PHY shall reject a low PHY power condition request by replying with a PMNAK primitive sequence.

9.15.2 Active PHY Power Condition

While in the active PHY power condition:

- a) The PHY is capable of transmitting information and responding to received information; and
- b) The PHY may consume more power than while the PHY is in a low PHY power condition.

9.15.3 Partial PHY Power Condition

The interface shall detect the OOB signaling sequence COMWAKE and COMRESET if in the Partial Interface power management state.

While in the Partial state, the interface shall be subjected to the low-transition density bit pattern (LTDP) sequences; the interface shall remain in the Partial state until receipt of a valid COMWAKE (or COMRESET) OOB signaling sequence.

Power dissipation in this Partial state shall be measured or calculated to be less than the PHY Active state, but more than the Slumber state.

The requirement for a "not-to-exceed" power dissipation limit in the Partial interface power management state is classified as vendor specific.

9.15.4 Slumber PHY Power Condition

The interface shall detect the OOB signaling sequence COMWAKE and COMRESET if in the Slumber Interface power management state.

While in the Slumber state, the interface shall be subjected to the low-transition density bit pattern (LTDP) sequences; the interface shall remain in the Slumber state until receipt of a valid COMWAKE (or COMRESET) OOB signaling sequence.

Power dissipation in this Slumber state shall be measured or calculated to be less than the PHY Ready state, and less than the Partial state.

The requirement for a "not-to-exceed" power dissipation limit in the Slumber interface power management state is classified as vendor specific.

9.16 Software Setting Preservation

When a device is enumerated, software will configure the device using SET FEATURES and other commands. These software settings are often preserved across software reset but not necessarily across hardware reset. In Parallel ATA, only commanded hardware resets can occur, thus legacy software only reprograms settings that are cleared for the particular type of reset it has issued. In Serial ATA, COMRESET is equivalent to hard reset and a non-commanded COMRESET may occur if there is an asynchronous loss of signal. Since COMRESET is equivalent to hardware reset, in the case of an asynchronous loss of signal some software settings may be lost without legacy software knowledge. In order to avoid losing important software settings without legacy driver knowledge, the software settings preservation ensures that the value of important software settings is maintained across a COMRESET. Software settings preservation may be enabled or disabled using SET FEATURES with a subcommand code of 06h. If a device supports software settings preservation, the feature shall be enabled by default.

9.16.1 COMRESET Preservation Requirements

The software settings that shall be preserved across COMRESET are listed below. The device is only required to preserve the indicated software setting if it supports the particular feature/command the setting is associated with.

INITIALIZE DEVICE PARAMETERS: Device settings established with the INITIALIZE DEVICE PARAMETERS command.

Power Management Feature Set Standby Timer: The Standby timer used in the Power Management feature set.

Read/Write Stream Error Log: The Read Stream Error Log and Write Stream Error Logs (accessed using READ LOG EXT and WRITE LOG EXT).

Security mode state: The security mode state established by Security Mode feature set commands (refer to section 6.13 of the ATA/6 specification). The device shall not transition to a different security mode state based on a COMRESET. For example, the device shall not transition from the SEC5: Unlocked / not Frozen state to state SEC4: Security enabled / Locked when a COMRESET occurs, instead the device shall remain in the SEC5: Unlocked / not Frozen state.

SECURITY FREEZE LOCK: The Frozen mode setting established by the SECURITY FREEZE LOCK command.

SECURITY UNLOCK: The unlock counter that is decremented as part of a failed SECURITY UNLOCK command attempt.

SET ADDRESS MAX (EXT): The maximum LBA specified in SET ADDRESS MAX or SET ADDRESS MAX EXT.

SET FEATURES (Device Initiated Interface Power Management): The Device Initiated Interface Power Management enable/disable setting (Word 79, bit 3 of Identify Device) established by the SET FEATURES command with a Subcommand code of 10h or 90h.

SET FEATURES (Write Cache Enable/Disable): The write cache enable/disable setting established by the SET FEATURES command with subcommand code of 02h or 82h.

SET FEATURES (Set Transfer Mode): PIO, Multiword, and UDMA transfer mode settings established by the SET FEATURES command with subcommand code of 03h.

SET FEATURES (Advanced Power Management Enable/Disable): The advanced power management enable/disable setting established by the SET FEATURES command with subcommand code of 05h or 85h. The advanced power management level established in the Sector Count register when advanced power management is enabled (SET FEATURES subcommand code 05h) shall also be preserved.

SET FEATURES (Read Look-Ahead): The read look-ahead enable/disable setting established by the SET FEATURES command with subcommand code of 55h or AAh.

SET FEATURES (Reverting to Defaults): The reverting to power-on defaults enable/disable setting established by the SET FEATURES command with a subcommand code of CCh or 66h.

SET MULTIPLE MODE: The block size established with the SET MULTIPLE MODE command.

SANITIZE FREEZE LOCK MODE: The Sanitize Frozen state established by the SANITIZE FREEZE LOCK EXT command.

There are several optional features defined in Serial ATA Revision 3.2. The following shows whether these features are supported or not.

9.17 Serial ATA Optional Features

There are several optional features defined in Serial ATA Revision 3.2. The following shows whether these features are supported or not.

9.17.1 Asynchronous Signal Recovery

The device supports asynchronous signal recovery defined in Serial ATA Revision 3.2.

9.17.2 Device Power Connector Pin 11 Definition

Serial ATA Revision 3.2 specification defines that Pin 11 of the power segment of the device connector may be used to provide the host with an activity indication and disabling of staggered spin-up.

9.17.3 Phy Event Counters

Phy Event Counters are an optional feature to obtain more information about Phy level events that occur on the interface. This information may aid designers and integrators in testing and evaluating the quality of the interface. A device indicates whether it supports the Phy event counters feature in IDENTIFY (PACKET) DEVICE Word 76, bit 10. The host determines the current values of Phy event counters by issuing the READ LOG EXT command with a log page of 11h. The counter values shall not be retained across power cycles. The counter values shall be preserved across COMRESET and software resets.

The counters defined can be grouped into three basic categories: those that count events that occur during Data FIS transfers, those that count events that occur during non-Data FIS transfers, and events that are unrelated to FIS transfers. Counters related to events that occur during FIS transfers may count events related to host-to-device FIS transfers, device-to-host FIS transfers, or bi-directional FIS transfers. A counter that records bi-directional events is not required to be the sum of the counters that record the same events that occur on device-to-host FIS transfers and host-to-device FIS transfers.

Implementations that support Phy event counters shall implement all mandatory counters, and may support any of the optional counters as shown in Table 39. Note that some counters may increment differently based on the speed at which non-Data FIS retries are performed by the host and device. Implementations may record CRC and non-CRC error events differently. For example, there is a strong likelihood that a disparity error may cause a CRC error. Thus, the disparity error may cause both the event counter that records non-CRC events and the event counter that records CRC events to be incremented for the same event. Another example implementation difference is how a missing EOF event is recorded; a missing EOF primitive may imply a bad CRC even though the CRC on the FIS may be correct. These examples illustrate that some Phy event counters are sensitive to the implementation of the counters themselves, and thus these implementation sensitive counters cannot be used as an absolute measure of interface quality between different implementations.

9.17.3.1 Counter Reset Mechanisms

There are two mechanisms by which the host can explicitly cause the Phy counters to be reset.

The first mechanism is to issue a BIST Activate FIS to the device. Upon reception of a BIST Activate FIS the device shall reset all Phy event counters to their reset value. The second mechanism uses the READ LOG EXT command. When the device receives a READ LOG EXT command for log page 11h and bit 0 in the Features register is set to one, the device shall return the current counter values for the command and then reset all Phy event counter values.

9.17.3.2 Counter Identifiers

Each counter begins with a 16-bit identifier. Table 39 defines the counter value for each identifier. Any unused counter slots in the log page should have a counter identifier value of 0h.

Optional counters that are not implemented shall not be returned in log page 11h. A value of '0' returned for a counter means that there have been no instances of that particular event. There is no required ordering for event counters within the log page; the order is arbitrary and selected by the device vendor.

For all counter descriptions, 'transmitted' refers to items sent by the device to the host and 'received' refers to items received by the device from the host.

Bits 14:12 of the counter identifier convey the number of significant bits that counter uses. All counter values consume a multiple of 16-bits. The valid values for bits 14:12 and the corresponding counter sizes are:

- 1h 16-bit counter
- 2h 32-bit counter
- 3h 48-bit counter
- 4h 64-bit counter

Any counter that has an identifier with bit 15 set to one is vendor specific. This creates a vendor specific range of counter identifiers from 8000h to FFFFh. Vendor specific counters shall observe the number of significant bits 14:12 as defined above.

| Identifier (Bits 11:0) | Mandatory / Optional | Description |
|---------------------------|-------------------------|---|
| 000h | Mandatory | No counter value; marks end of counters in the page |
| 001h | Mandatory | Command failed and ICRC bit set to one in Error register |
| 002h | Optional | R_ERR response for Data FIS |
| 003h | Optional | R_ERR response for Device-to-Host Data FIS |
| 004h | Optional | R_ERR response for Host-to-Device Data FIS |
| 005h | Optional | R_ERR response for Non-data FIS |
| 006h | Optional | R_ERR response for Device-to-Host Non-data FIS |
| 007h | Optional | R_ERR response for Host-to-Device Non-data FIS |
| 008h | Optional | Not supported (Device-to-Host non-Data FIS retries) |
| 009h | Optional | Transitions from drive PhyRdy to drive PhyNRdy |
| 00Ah | Mandatory | Signature Device-to-Host Register FISes sent due to a COMRESET |
| 00Bh | Optional | CRC errors within a Host-to-Device FIS |
| 00Dh | Optional | Non-CRC errors within a Host-to-Device FIS |
| 00Fh | Optional | Not supported (R_ERR response for Host-to-Device Data FIS due to CRC errors) |
| 010h | Optional | Not supported (R_ERR response for Host-to-Device Data FIS due to non-CRC errors) |
| 012h | Optional | Not supported (R_ERR response for Host-to-Device Non-data FIS due to CRC errors) |
| 013h | Optional | Not supported (R_ERR response for Host-to-Device Non-data FIS due to non-CRC errors) |

Table 39 Phy Event Counter Identifiers

9.17.3.2.1 Counter Definitions

The counter definitions in this section specify the events that a particular counter identifier represents.

9.17.3.2.1.1 Identifier 000h

There is no counter associated with identifier 000h. A counter identifier of 000h indicates that there are no additional counters in the log page.

9.17.3.2.1.2 Identifier 001h

The counter with identifier 001h returns the number of commands that returned an ending status with the ERR bit set to one in the Status register and the ICRC bit set to one in the Error register.

9.17.3.2.1.3 Identifier 002h

The counter with identifier 002h returns the sum of (the number of transmitted Device-to-Host Data FISes to which the host responded with R_ERRP) and (the number of received Host-to-Device Data FISes to which the device responded with R_ERRP).

9.17.3.2.1.4 Identifier 003h

The counter with identifier 003h returns the number of transmitted Device-to-Host Data FISes to which the host responded with R_ERRP.

9.17.3.2.1.5 Identifier 004h

The counter with identifier 004h returns the number of received Host-to-Device Data FISes to which the device responded with R_ERRP. The count returned for identifier 004h is not required to be equal to the sum of the counters with identifiers 00Fh and 010h.

9.17.3.2.1.6 Identifier 005h

The counter with identifier 005h returns the sum of (the number of transmitted Device-to-Host non-Data FISes to which the host responded with R_ERRP) and (the number of received Host-to-Device non-Data FISes to which the device responded with R_ERRP). Retries of non-Data FISes are included in this count.

9.17.3.2.1.7 Identifier 006h

The counter with identifier 006h returns the number of transmitted Device-to-Host non-Data FISes to which the host responded with R_ERRP. Retries of non-Data FISes are included in this count.

9.17.3.2.1.8 Identifier 007h

The counter with identifier 007h returns the number of received Host-to-Device non-Data FISes to which the device responded with R_ERRP. Retries of non-Data FISes are included in this count.

9.17.3.2.1.9 Identifier 009h

The counter with identifier 009h returns the number of times the device transitioned into the PHYRDY state from the PHYNRDY state, including but not limited to asynchronous signal events, power management events, and COMRESET events. If interface power management is enabled, then this counter may be incremented due to interface power management transitions.

9.17.3.2.1.10 Identifier 00Ah

The counter with identifier 00Ah returns the number of transmitted Device-to-Host Register FISes with the device reset signature in response to a COMRESET, which were successfully followed by an R_OK from the host.

9.17.3.2.1.11 Identifier 00Bh

The counter with identifier 00Bh returns the number of received Host-to-Device FISes of all types (Data and non-Data) to which the device responded with R_ERR_P due to CRC error.

9.17.3.2.1.12 Identifier 00Dh

The counter with identifier 00Dh returns the number of received Host-to-Device FISes of all types (Data and non-Data) to which the devices responded with R_ERR_P for reasons other than CRC error.

9.17.3.3 READ LOG EXT Log Page 11h

READ LOG EXT log page 11h is one page (512 bytes) in length. The first Dword of the log page contains information that applies to the rest of the log page. Software should continue to process counters until a counter identifier with value 0h is found or the entire page has been read. A counter identifier with value 0h indicates that the log page contains no more counter values past that point. Log page 11h is defined in Table 40.

| Byte | 7 | 6 | 5 | 4 | 3 | 2 | 1 | 0 |
|----------------------|-------------------------|---|---|---|---|---|---|---|
| 0 | Reserved | | | | | | | |
| 1 | Reserved | | | | | | | |
| 2 | Reserved | | | | | | | |
| 3 | Reserved | | | | | | | |
| ... | ... | | | | | | | |
| n | Counter n Identifier | | | | | | | |
| n+1 | | | | | | | | |
| n+2 | | | | | | | | |
| n + Counter n Length | Counter n Value | | | | | | | |
| ... | ... | | | | | | | |
| 508 | Reserved | | | | | | | |
| 509 | | | | | | | | |
| 510 | | | | | | | | |
| 511 | Data Structure Checksum | | | | | | | |

Table 40 READ LOG EXT Log Page 11h Data Structure Definition

Counter n Identifier

Phy event counter identifier that corresponds to Counter n Value. Specifies the particular event counter that is being reported. The Identifier is 16 bits in length. Valid identifiers are listed in Table 40.

Counter n Value

Value of the Phy event counter that corresponds to Counter n Identifier. The number of significant bits is determined by Counter n Identifier bits 14:12 (as defined in Table 39). The length of Counter n Value shall always be a multiple of 16-bits. All counters are one-extended. For example, if a counter is only physically implemented as 8-bits when it reaches the maximum value of 0xFF, it shall be one-extended to 0xFFFF. The counter shall stop (and not wrap to zero) after reaching its maximum value.

Counter n Length

Size of the Phy event counter as defined by bits 14:12 of Counter n Identifier. The size of the Phy event counter shall be a multiple of 16-bits.

Data Structure Checksum

The data structure checksum is the 2's complement of the sum of the first 511 bytes in the data structure. Each byte shall be added with unsigned arithmetic and overflow shall be ignored. The sum of all 512 bytes of the data structure will be zero when the checksum is correct.

Reserved All reserved fields shall be cleared to zero

9.17.4 NCQ NON-DATA (63h)

The NCQ NON-DATA feature allows the host to manage the outstanding NCQ commands and/or affect the processing of NCQ commands.

The NCQ NON-DATA command is a non-data NCQ command. Only specified NCQ NON-DATA subcommands are executed as Immediate NCQ commands.

NCQ NON-DATA cmd, LBA fields should not be set to reserved.

LBA fields are optionally used in SetFeatures cmd.

If NCQ is disabled and an NCQ NON-DATA command is issued to the device, then the device aborts the command with the ERR bit set to one in the Status register and the ABRT bit set to one in the Error register. This command is prohibited for devices that implement the PACKET feature set. The queuing behavior of the device depends on which subcommand is specified.

| Register | 7 | 6 | 5 | 4 | 3 | 2 | 1 | 0 |
|------------------|---------------------|---|-----|---|------------|---|---|---|
| Features(7:0) | Subcommand Specific | | | | Subcommand | | | |
| Features(15:8) | Subcommand Specific | | | | | | | |
| Count(7:0) | TAG | | | | Reserved | | | |
| Count(15:8) | Subcommand Specific | | | | | | | |
| LBA(7:0) | Subcommand Specific | | | | | | | |
| LBA(15:8) | Subcommand Specific | | | | | | | |
| LBA(23:16) | Subcommand Specific | | | | | | | |
| LBA(31:24) | Subcommand Specific | | | | | | | |
| LBA(39:32) | Subcommand Specific | | | | | | | |
| LBA(47:40) | Subcommand Specific | | | | | | | |
| ICC(7:0) | Reserved | | | | | | | |
| Auxiliary(7:0) | Reserved | | | | | | | |
| Auxiliary(15:8) | Reserved | | | | | | | |
| Auxiliary(23:16) | Subcommand Specific | | | | | | | |
| Auxiliary(31:24) | Reserved | | | | | | | |
| Device(7:0) | Res | 1 | Res | 0 | Reserved | | | |
| Command(7:0) | 63h | | | | | | | |

Table 41 NCQ NON-DATA - Command Definition

Table 41 defines the Subcommand values. If an invalid subcommand is specified, then the device aborts the command with the ERR bit set to one in the Status register, the ABRT bit set to one in the Error register, and causes all outstanding commands to be aborted.

| Subcommand | Description | Reference |
|------------|-------------------|---|
| 0h | Abort NCQ queue | 11.15.1 Abort NCQ Queue Subcommand (0h) |
| 1h | Deadline Handling | 11.15.2 Deadline Handling Subcommand (1h) |
| 2h - 4h | Reserved | |
| 5h | SET FEATURES | 11.15.3 Set Features Subcommand (5h) |

Table 42 Subcommand Field

Subcommand Specific (TTAG) is the selected queue TAG. This allows the host to select the specific outstanding queued command to be managed.

The error and normal returns for this command are subcommand specific.

9.17.4.1 Abort NCQ Queue Subcommand (0h)

A Subcommand set to 0h specifies the Abort NCQ Queue subcommand (see 11.15.1 Abort NCQ Queue Subcommand (0h)). The Abort NCQ Queue subcommand is an immediate NCQ command. Support for this subcommand is indicated in the NCQ NON-DATA log (see 9.17.4.3 Read Log Ext Log Page 12h)

The Abort NCQ Queue subcommand affects only those NCQ commands for which the device has indicated command acceptance before accepting this NCQ NON-DATA command.

This command is prohibited for devices that implement the PACKET feature set.

Normal Outputs

If a supported Abort Type parameter is specified, then the device indicates success, even if the command results in no commands being aborted.

When an Abort NCQ Queue command completes successfully, a Set Device Bits FIS is sent to the host to complete the Abort subcommand and commands that were aborted as a consequence of the Abort subcommand by setting the ACT bits for those commands to one. This SDB FIS may also indicate other completed commands.

Error Outputs

The device returns command aborted if:

- a) NCQ is disabled and an Abort NCQ queue command is issued to the device;
- b) The value of the TTAG field equals the value of the TAG field;
- c) The value of the TTAG field is an invalid TAG number; or
- d) An unsupported Abort type parameter is specified.

9.17.4.2 Deadline Handling Subcommand (1h)

A Subcommand set to 1h specifies the Deadline Handling Subcommand (see 11.15.2 Deadline handling Subcommand (1h)). This subcommand controls how NCQ Streaming commands are processed by the device. Support for this subcommand is indicated in the NCQ NON-DATA Log (see 9.17.4.3 Read Read Log Ext Log Page 12h).

The state of the WDNC and RDNC bits are preserved across software resets and COMRESETs (via Software Setting Preservations), and are not preserved across power cycles.

Normal Outputs

If this Deadline Handling Subcommand command is supported, the device returns command completed with no error.

When a Deadline Handling Subcommand command completes successfully, a Set Device Bits FIS is sent to the host to complete the Deadline Handling subcommand. This SDB FIS may also indicate other completed commands.

Error Outputs

The device returns command aborted if NCQ is disabled and a Deadline Handling command is issued to the device;

SET FEATURES Subcommand (5h)

The SET FEATURES subcommand functionality and behavior is dependent on all requirements of the SET FEATURES command defined in ACS-3.

Normal Outputs

Upon successful completion of one or more outstanding commands, the device shall transmit a Set Device Bits FIS with the Interrupt bit set to one and one or more bits set to one in the ACT field corresponding to the bit position for each command TAG that has completed since the last status notification was transmitted. The ERR bit in the Status register shall be cleared to zero and the value in the Error register shall be zero.

Error Outputs

If the device has received a command that has not yet been acknowledged by clearing the BSY bit to zero and an error is encountered, the device shall transmit a Register Device to Host FIS (see Table 107) with the ERR bit set to one and the BSY bit cleared to zero in the Status field, the ATA error code in the Error field.

9.17.4.3 READ LOG EXT Log Page 12h

To determine the supported NCQ NON-DATA subcommands and their respective features, host software reads log address 12h. This log is supported if the NCQ NON-DATA command is supported (i.e., IDENTIFY DEVICE word 77 bit 5 is set to one). Table 43 defines the 512 bytes that make up the SATA NCQ NON-DATA log. The value of the General Purpose Logging Version word is 0001h.

| Dword | Bits | Description |
|-------|---------------|--------------------------------------|
| 0 | Subcommand 0h | |
| | 31-5 | Reserved |
| | 4 | Supports Abort Selected TTAG |
| | 3 | Supports Abort Non-Streaming |
| | 2 | Supports Abort Streaming |
| | 1 | Supports Abort All |
| | 0 | Supports Abort NCQ |
| 1 | Subcommand 1h | |
| | 31-3 | Reserved |
| | 2 | Supports Read Data Not Continue |
| | 1 | Supports Write Data Not Continue |
| | 0 | Supports DEADLINE HANDLING |
| 2-4 | 31-0 | Reserved |
| 5 | Subcommand 5h | |
| | 31-1 | Reserved |
| | 1 | Supports Set Features(see 13.7.5.13) |
| 6-127 | 31-0 | Reserved |

Table 43 NCQ NON-DATA Log (12h) Data Structure Definition

9.17.4.3.1 Supports the Abort NCQ Subcommand

If Supports the Abort NCQ subcommand is set to one, then the device supports the Abort NCQ Queue command (11.15.1 Abort NCQ Queue Subcommand (0h)). If Supports the Abort NCQ subcommand is cleared to zero, then the device does not support the Abort NCQ Queue command.

9.17.4.3.2 Supports Abort All

If Supports Abort All is set to one, then the device supports the value of Abort All for the Abort Type parameter of the Abort NCQ Queue command. If Supports Abort All is cleared to zero, then the device does not support the value of Abort All for the Abort Type parameter of the Abort NCQ Queue command.

9.17.4.3.3 Supports Abort Streaming

If Supports Abort Streaming is set to one, then the device supports the value of Abort Streaming for the Abort Type parameter of the Abort NCQ Queue command. If Supports Abort Streaming is cleared to zero, then the device does not support the value of Abort Streaming for the Abort Type parameter of the Abort NCQ Queue command.

9.17.4.3.4 Supports Abort Non-Streaming

If Supports Abort Non-Streaming is set to one, then the device supports the value of Abort Non-Streaming for the Abort Type parameter of the Abort NCQ Queue command. If Supports Abort Non-Streaming is cleared to zero, then the device does not support the value of Abort Non-Streaming for the Abort Type parameter of the Abort NCQ Queue command.

9.17.4.3.5 Supports the Abort Selected TTAG

If Supports Abort Selected TTAG is set to one, then the device supports the value of Abort Selected for the Abort Type parameter of the Abort NCQ Queue command. If Supports Abort Selected TTAG is cleared to zero, then the device does not support the value of Abort Selected for the Abort Type parameter of the Abort NCQ Queue command.

9.17.4.3.6 Supports the Deadline Handling Subcommand

If Supports the Deadline Handling subcommand is set to one, then the device supports the Deadline Handling command. If the Supports the Deadline Handling subcommand is cleared to zero, then the device does not support the Deadline Handling command.

9.17.4.3.7 Supports WDNC

If Supports WDNC is set to one, then the device supports the WDNC bit of the DEADLINE HANDLING command. If Supports WDNC is cleared to zero, then the device does not support the WDNC bit of the DEADLINE HANDLING command.

9.17.4.3.8 Supports RDNC

If Supports RDNC is set to one, then the device supports the RDNC bit of the Deadline Handling command. If Supports RDNC is cleared to zero, then the device does not support the WDNC bit of the Deadline Handling command.

9.17.4.3.9 Supports Set Features

If Supports Set Features is set to one, then the device supports the value of Set Features for the SET FEATURES subcommand of the NCQ NON-DATA command. If the Set Features bit is cleared to zero, then the device does not support the SET FEATURES subcommand of the NCQ NON-DATA command.

9.17.5 Rebuild Assist

The Rebuild Assist mode provides a method for a host controlling the rebuild process to determine that logical sectors on the failed device are unreadable without having to read every LBA to determine the unreadable logical sectors (i.e., the read command is terminated with an error and the failed LBA is reported in the sense data). The storage array controller then may reconstruct the failed logical sectors. The remaining logical sectors may be copied to the replacement device.

If the Rebuild Assist feature is enabled, then the host should issue sequential READ FPDMA QUEUED commands to extract the available data from the device.

If a READ FPDMA QUEUED command does not detect an unrecovered error, then the command should complete without error.

The Rebuild Assist feature allows reporting of an unrecovered read error or an unrecovered write error that is either predicted (i.e., a predicted unrecovered error) or unpredicted (i.e., an unpredicted unrecovered error).

If a device processes a READ FPDMA QUEUED command with the RARC bit set to one, then Rebuild Assist feature shall not affect processing of the READ FPDMA QUEUED command.

If the device processes a READ FPDMA QUEUED command with the RARC bit cleared to zero and detects a predicted unrecovered error, the following information recorded in the Queued Error log.

- A) The Sense Key field is set to Bh(ABORTED COMMAND);
- B) The Additional Sense Code field and the Additional Sense Code Qualifier field is set to 1103h (MULTIPLE READ ERRORS);
- C) The LBA field is set to the LBA of the first unrecovered logical sector; and
- D) The Final LBA In Error field is set to the LBA of the last predicted unrecovered logical sector in a sequence of contiguous unrecovered logical sectors that started with the first LBA in error.

9.17.5.1 Rebuild Assist Log (15h)

If the device supports the Rebuild Assist feature (i.e., IDENTIFY DEVICE data Word 78 bit 11 is set to one), then the Rebuild Assist log shall be supported.

| Byte | 7 | 6 | 5 | 4 | 3 | 2 | 1 | 0 |
|--------------|-----------------------------|--------------------------------|---|---|---|---|---|------------------------|
| 0 | Reserved | | | | | | | Rebuild Assist Enabled |
| 1...6 | Reserved | | | | | | | |
| 7 | Physical Element Length (N) | | | | | | | |
| 8 | (MSB) | Disabled Physical Element Mask | | | | | | (LSB) |
| 7 + N | | | | | | | | |
| 8 + N | (MSB) | Disabled Physical Elements | | | | | | (LSB) |
| 7+(2×N) | | | | | | | | |
| 8+(2×N)..511 | Reserved | | | | | | | |

Table 44 Rebuild Assist Log (15h) Data Structure Definition

Physical Element Length

The Physical Element Length field indicates the number of bytes in the Disabled Physical Element Mask field and the number of bytes in the Disabled Physical Elements field.

The device shall ignore any attempt by the host to change the value of this field when writing to the Rebuild Assist log.

Disabled Physical Element Mask

The Disabled Physical Element Mask field indicates that bits in the Disabled Physical Elements field are supported. The device shall ignore any attempt by the host to change the value of this field when writing to the Rebuild Assist log.

Disabled Physical Elements

The Disabled Physical Elements field specifies if physical elements shall be disabled. Each bit that is set to one in the Disabled Physical Elements field specifies that LBAs associated with this physical element shall respond to read commands and write commands as if the associated LBAs have predicted errors.

Each bit that is set to zero in the Disabled Physical Elements field specifies that LBAs associated with this physical element shall respond to read commands and write commands as if the associated LBAs do not have predicted errors.

9.17.5.2 Enabling the Rebuild Assist Feature

If the host writes to the Rebuild Assist log and sets the Rebuild Assist Enabled field to one, then:

- a) The device will initiate a self test of the physical elements contained within the device and should disable any physical elements that are not functioning correctly;
- b) The device shall initialize the Disabled Physical Elements from the results of the self-test;
- c) The device shall minimize device-initiated background activities; and
- d) The device shall enable the Rebuild Assist feature. The host may verify that Rebuild Assist feature is enabled by reading the Rebuild Assist log, and then examining the data returned and verifying that the Rebuild Assist Enabled field is set to one

9.17.5.3 Using the Rebuild Assist Feature Overview

If the Rebuild Assist feature is enabled, then the host should issue sequential READ FPDMA QUEUED commands to extract the available data from the device. If a READ FPDMA QUEUED command does not detect an unrecovered error, then the command should complete without error.

The Rebuild Assist feature allows reporting of an unrecovered read error or an unrecovered write error that is either predicted (i.e., a predicted unrecovered error) or unpredicted (i.e., an unpredicted unrecovered error). If a device processes a READ FPDMA QUEUED command with the RARC bit set to one, then Rebuild Assist feature shall not affect processing of the READ FPDMA QUEUED command.

9.17.5.4 Disabling the Rebuild Assist Feature

If the device supports the Rebuild Assist feature (i.e., IDENTIFY DEVICE data Word 78 bit 11 is set to one), then The Rebuild Assist feature shall be disabled if:

- a) The device processes a power cycle; or
- b) The device processes a command to write to the Rebuild Assist log (see 13.7.8) with the Rebuild Assist Enabled bit cleared to zero.

9.17.6 Power Disable

The Power Disable feature is optional. If supported and enabled, the Power Disable feature may be used to disable power to the device circuitry which enables a system that supports this feature to perform a hard reset of the drive.

When deploying drives in systems that do not support this feature, it is recommended that you select part numbers without this option.

9.18 SCT Command Transport Feature Set

9.18.1 Overview

9.18.1.1 Introduction

SMART Command Transport (SCT) is the method for the drive to receive commands using log page E0h and transporting data using log page E1h. These log pages are used as follows:

| | Log page E0h | Log Page E1h |
|----------------|---------------|------------------------------|
| Write log page | Issue Command | Send Data to the drive |
| Read log page | Return Status | Received Data from the drive |

Table 45 SCT Log Page and Direction

There are two ways to access the log pages: using SMART READ/WRITE LOG and READ/WRITE LOG EXT. Both sets of commands access the same log pages and provide the same capabilities.

The log directory for log pages E0h and E1h should report a length of one. The length of log page E1h does not indicate the length of an SCT data transfer.

If SMART is supported, but not enabled, the drive supports SMART READ/WRITE LOG for Log page E0h and E1h.

If security is enabled and password has not been issued to unlock the device, all SCT commands will fail.

9.18.1.2 Capability Definition

Capability Identification is performed by issuing Identify Device command. Word 206 of Identify Data is used to determine if SCT is enabled and which SCT Action Codes are supported.

| Word | Description | |
|------|-------------------------|--|
| 206 | SCT Command set support | |
| | 15-12 | Vendor Specific |
| | 11-6 | Reserved |
| | 5 | Action Code 5 (SCT Data Table) supported |
| | 4 | Action Code 4 (Features Control) supported |
| | 3 | Action Code 3 (Error Recovery Control) supported |
| | 2 | Action Code 2 (SCT Write Same) supported |
| | 1 | Obsolete |
| | 0 | SCT Feature Set supported (includes SCT status) |

Table 46 Identify Device Information Word 206

9.18.1.3 SCT Command Nesting and Intermingling with Standard Commands

In general, standard ATA commands can be intermingled with SCT Commands but SCT commands cannot be nested. SCT commands that do require a follow-on data transfer operation never have an issue with being intermixed with any ATA commands or each other. SCT commands that do require data transfer, on the other hand, may not be nested; that is, if a key command that requires a data transfer is issued, all data transfer – to or from the host – must complete before another SCT command is issued. In most cases, however, ATA read/write commands may be inserted in between SCT data transfers, that is, between complete SMART Read Log/Write Log commands. Furthermore, any reset (power-on, software or hardware) will cause the SCT command to be aborted.

9.18.1.4 Resets

If an SCT command is executing, any reset including Soft Reset, Hard Reset, COMRESET, and Power-On Reset all cause the command to be terminated. This could result in partial command execution or data loss. There is no indication once the drive becomes ready that the previous command was terminated.

9.18.2 SCT Command Protocol

9.18.2.1 Command Transport

SCT Command Transport occurs when a 512-byte data packet (called “Key Sector”) is created and the written to SMART or extended log page E0h. The key sector specifies Action and Function Codes along with the parameters that are required to perform the action.

9.18.2.1.1 Issue SCT Command Using SMART

| Command Block Output Registers | | | | | | | | |
|--------------------------------|-----|---|---|---|---|---|---|---|
| Register | 7 | 6 | 5 | 4 | 3 | 2 | 1 | 0 |
| Feature | D6h | | | | | | | |
| Sector Count | 01h | | | | | | | |
| Sector Number | E0h | | | | | | | |
| Cylinder Low | 4Fh | | | | | | | |
| Cylinder High | C2h | | | | | | | |
| Device/Head | - | - | - | D | - | - | - | - |
| Command | B0h | | | | | | | |

Table 47 Output Registers of SCT Command Using SMART

| Command Block Input Registers (Success) | | | | | | | | | Command Block Input Registers (Error) | | | | | | | | |
|---|-------------------------------------|---|---|---|---|---|---|---|---------------------------------------|-------------------------------------|---|---|---|---|---|---|---|
| Register | 7 | 6 | 5 | 4 | 3 | 2 | 1 | 0 | Register | 7 | 6 | 5 | 4 | 3 | 2 | 1 | 0 |
| Error | 00h | | | | | | | | Error | 04h | | | | | | | |
| Sector Count | Depends on command (LSB) | | | | | | | | Sector Count | Extended Status code (LSB) | | | | | | | |
| Sector Number | Depends on command (MSB) | | | | | | | | Sector Number | Extended Status code (MSB) | | | | | | | |
| Cylinder Low | Number of sectors to transfer (LSB) | | | | | | | | Cylinder Low | Number of sectors to transfer (LSB) | | | | | | | |
| Cylinder High | Number of sectors to transfer (MSB) | | | | | | | | Cylinder High | Number of sectors to transfer (MSB) | | | | | | | |
| Device/Head | - | - | - | - | - | - | - | - | Device/Head | - | - | - | - | - | - | - | - |
| Status | 50h | | | | | | | | Status | 51h | | | | | | | |

Table 48 Input Registers of SCT Command Using SMART

9.18.2.1.2 Issue SCT Command Using Write Log Ext

| Command Block Output Registers | | | | | | | | | | |
|--------------------------------|----------|----------|---|---|---|---|---|---|---|--|
| Register | | 7 | 6 | 5 | 4 | 3 | 2 | 1 | 0 | |
| Feature | Current | Reserved | | | | | | | | |
| | Previous | Reserved | | | | | | | | |
| Sector Count | Current | 01h | | | | | | | | |
| | Previous | 00h | | | | | | | | |
| LBA Low | Current | E0h | | | | | | | | |
| | Previous | Reserved | | | | | | | | |
| LBA Mid | Current | 00h | | | | | | | | |
| | Previous | 00h | | | | | | | | |
| LBA High | Current | Reserved | | | | | | | | |
| | Previous | Reserved | | | | | | | | |
| Device/Head | | - | - | - | D | - | - | - | - | |
| Command | | 3Fh | | | | | | | | |

Table 49 Input Registers of SCT Command Using Write Log Ext

| Command Block Input Registers (Success) | | | | | | | | | Command Block Input Registers (Error) | | | | | | | | | | | | |
|---|-------|--------------------------|---|---|---|---|---|---|---------------------------------------|-------------|--------------|-------|----------------------------|---|---|---|---|---|---|--|--|
| Register | | 7 | 6 | 5 | 4 | 3 | 2 | 1 | 0 | Register | | 7 | 6 | 5 | 4 | 3 | 2 | 1 | 0 | | |
| Error | | 00h | | | | | | | | | Error | | 04h | | | | | | | | |
| Sector Count | HOB=0 | Depends on command (LSB) | | | | | | | | | Sector Count | HOB=0 | Extended Status Code (LSB) | | | | | | | | |
| | HOB=1 | Reserved | | | | | | | | | | HOB=1 | Reserved | | | | | | | | |
| LBA Low | HOB=0 | Depends on command (MSB) | | | | | | | | | LBA Low | HOB=0 | Extended Status Code (MSB) | | | | | | | | |
| | HOB=1 | Reserved | | | | | | | | | | HOB=1 | Reserved | | | | | | | | |
| LBA Mid | HOB=0 | Number of sectors (LSB) | | | | | | | | | LBA Mid | HOB=0 | Number of sectors (LSB) | | | | | | | | |
| | HOB=1 | Reserved | | | | | | | | | | HOB=1 | Reserved | | | | | | | | |
| LBA High | HOB=0 | Number of sectors (MSB) | | | | | | | | | LBA High | HOB=0 | Number of sectors (MSB) | | | | | | | | |
| | HOB=1 | Reserved | | | | | | | | | | HOB=1 | Reserved | | | | | | | | |
| Device/Head | | - | - | - | - | - | - | - | - | Device/Head | | - | - | - | - | - | - | - | - | | |
| Status | | 50h | | | | | | | | | Status | | 51h | | | | | | | | |

All ATA “previous” registers are reserved in Write Log Ext responses.

Table 50 Output Registers of SCT Command Using Write Log Ext

9.18.2.1.3 Key Sector Format

An SCT command (Key Sector) is always 512 bytes long. Table below shows the generic format of an SCT command.

| Byte | Field | Words | Description |
|-------|---------------|--------------------|---|
| 1:0 | Action Code | 1 | This field defines the command type and generally specifies the type of data being accessed, such as sector or physical action being performed, such as seek. |
| 3:2 | Function Code | 1 | This field specifies the type of access, and varies by command. For example, this can specify read, write, verify, etc. |
| X:4 | Parameter1 | Depends on command | Depends on command |
| Y:x+1 | Parameter2 | Depends on command | Depends on command |
| ... | ... | ... | ... |
| | Total Words | 256 | |

Table 51 Key Sector Format

The action codes are defined in Table 52 below.

| Action Code | Block Data | TF Data | Description |
|-------------|------------|---------|------------------------------------|
| 0000h | - | - | Reserved |
| 0001h | Read/Write | Y | Long Sector Access (Not Supported) |
| 0002h | Write | N | SCT Write Same |
| 0003h | - | Y | Error Recovery Control |
| 0004h | - | Y | Features Control |
| 0005h | Read | N | SCT Data Table |
| 0006h-BFFFh | - | - | Reserved |
| C000h-FFFFh | - | - | Vendor Specific |

Table 52 SCT Action Code List

9.18.2.1.4 Extended Status Code

| Status Code | Definition |
|-------------|---|
| 0000h | Command complete without error |
| 0001h | Invalid Function Code |
| 0002h | Input LBA out of range |
| 0003h | Request sector count overflow. The number of sectors requested to transfer (Sector Count register) in the read or write log command is larger than required by SCT command. |
| 0004h | Invalid Function code in Error Recovery command |
| 0005h | Invalid Selection code in Error Recovery command |
| 0006h | Host read command timer is less than minimum value |
| 0007h | Host write command timer is less than minimum value |
| 0008h | Background SCT command was aborted because of an interrupting host command |
| 0009h | Background SCT command was terminated because of unrecoverable error |
| 000Ah | Invalid Function code in Long Sector Access command |
| 000Bh | SCT data transfer command was issued without first issuing an SCT command |
| 000Ch | Invalid Function code in Feature Control command |
| 000Dh | Invalid Feature code in Feature Control command |
| 000Eh | Invalid New State value in Feature Control command |
| 000Fh | Invalid Option Flags in Feature Control command |
| 0010h | Invalid SCT Action code |
| 0011h | Invalid Table ID (table not supported) |
| 0012h | Command was aborted due to drive security being locked |
| 0013h | Invalid revision code |
| 0015h | The most recent non-SCT command returned command completion with an error due to the SCT Error Recovery Control Read Command Timer or SCT Error Recovery Control Write Command Timer expiring |
| 0017h | Blocking SCT Write Same command was terminated because of unrecoverable error |
| 0018h-BFFFh | Reserved |
| C000h-C002h | Vendor Specific |
| C003h | Overlay switch failure in Long Sector Access command |
| C004h | Read Long failure |
| C005h | Write Long failure |
| C006h | Write Cache enable failure |
| C007h-FFFEh | Vendor Specific |
| FFF0h-FFFEh | Reserved |
| FFFFh | SCT command executing in background |

Table 53 Extended Status Code

9.18.2.2 Data Transfer

Once an SCT command has been issued, status can be checked and data can be transferred. Data transfer uses log page E1h.

9.18.2.2.1 Read/Write SCT Data Using SMART

| Command Block Output Registers | | | | | | | | |
|--------------------------------|-------------------------------------|---|---|---|---|---|---|---|
| Register | 7 | 6 | 5 | 4 | 3 | 2 | 1 | 0 |
| Feature | D5h(Read)/D6h(Write) | | | | | | | |
| Sector Count | Number of sectors to be transferred | | | | | | | |
| Sector Number | E1h | | | | | | | |
| Cylinder Low | 4Fh | | | | | | | |
| Cylinder High | C2h | | | | | | | |
| Device/Head | - | - | - | D | - | - | - | - |
| Command | B0h | | | | | | | |

Table 54 Input Registers of SCT Data Transfer Using SMART

9.18.2.2.2 Read/Write SCT Data Using Read/Write Log Ext

| Command Block Output Registers | | | | | | | | |
|--------------------------------|----------------------|------------|---|---|---|---|---|---|
| Register | 7 | 6 | 5 | 4 | 3 | 2 | 1 | 0 |
| Feature | Current | Reserved | | | | | | |
| | Previous | Reserved | | | | | | |
| Sector Count | Current | 01h or 08h | | | | | | |
| | Previous | 00h | | | | | | |
| LBA Low | Current | E1h | | | | | | |
| | Previous | Reserved | | | | | | |
| LBA Mid | Current | 00h | | | | | | |
| | Previous | 00h | | | | | | |
| LBA High | Current | Reserved | | | | | | |
| | Previous | Reserved | | | | | | |
| Device/Head | - | - | - | D | - | - | - | - |
| Command | 2Fh(Read)/3Fh(Write) | | | | | | | |

Table 55 Input Registers of SCT Data Transfer using Read/Write Log Ext

9.18.2.3 SCT Status Request

Once an SCT command has been issued, a status is reported in the ATA registers. This status indicates that the command was accepted or that an error occurred. This ATA status return does not indicate successful completion of the SCT actions. Some commands can take several minutes or even hours to execute. In this case, the host can determine execution progress by requesting SCT status.

Log page E0h contains the status information. Reading log page E0h retrieves the status information. The SCT status may be acquired any time that the host is allowing to send a command to the device. This command will not change the power state of the drive, nor terminate any background activity, including any SCT command in progress.

9.18.2.3.1 SCT Status Request Using SMART

| Command Block Output Registers | | | | | | | | |
|--------------------------------|-----|---|---|---|---|---|---|---|
| Register | 7 | 6 | 5 | 4 | 3 | 2 | 1 | 0 |
| Feature | D5h | | | | | | | |
| Sector Count | 01h | | | | | | | |
| Sector Number | E0h | | | | | | | |
| Cylinder Low | 4Fh | | | | | | | |
| Cylinder High | C2h | | | | | | | |
| Device/Head | - | - | - | D | - | - | - | - |
| Command | B0h | | | | | | | |

Table 56 Input Registers of SCT Status Request Using SMART

9.18.2.3.2 SCT Status Request Using Read Log Ext

| Command Block Output Registers | | | | | | | | |
|--------------------------------|----------|----------|---|---|---|---|---|---|
| Register | 7 | 6 | 5 | 4 | 3 | 2 | 1 | 0 |
| Feature | Current | Reserved | | | | | | |
| | Previous | Reserved | | | | | | |
| Sector Count | Current | 01h | | | | | | |
| | Previous | 00h | | | | | | |
| LBA Low | Current | E0h | | | | | | |
| | Previous | Reserved | | | | | | |
| LBA Mid | Current | 00h | | | | | | |
| | Previous | 00h | | | | | | |
| LBA High | Current | Reserved | | | | | | |
| | Previous | Reserved | | | | | | |
| Device/Head | - | - | - | D | - | - | - | - |
| Command | 2Fh | | | | | | | |

Table 57 Input Registers of SCT Status Request Using Read Log Ext

9.18.2.3.3 Format of SCT Status Response

| Byte | Type | Field Name | Value | Description |
|--------|-----------|----------------------|-------|---|
| 1:0 | Word | Format Version | 0003h | Status Response format version number |
| 3:2 | Word | SCT Version | | Manufacturer's vendor specific implementation version number |
| 5:4 | Word | SCT Spec. | 0001h | Highest level of SCT Technical Report supported |
| 9:6 | Dword | Status Flags | | Bit 0 : Segment Initialized Flag If this bit is set to 1, an SCT Write Same command write to all LBAs of the drive has completed without error. This bit shall be cleared to 0 when any user LBA is written, even if write cache is enabled. This bit is also cleared if the capacity of the drive is changed via SETMAX, SETMAX EXT or DCO. This bit is preserved through a power cycle. Bit 1-31 : Reserved |
| 10 | Byte | Drive Status | | 0 = Active waiting for a command 1 = Stand-by 2 = Sleep 3 = DST executing in background 4 = SMART ODC executing in background 5 = SCT executing in background |
| 13:11 | Byte[3] | reserved | 00h | |
| 15:14 | Word | Extended Status Code | | Status Of last SCT command issued. FFFFh if SCT command executing in background. |
| 17:16 | Word | Action Code | | Action code of last SCT command issued. If the Extended Status Code is FFFFh, this is the Action Code of the command that is current executing. |
| 19:18 | Word | Function Code | | Function code of last SCT command issued. If the Extended Status Code is FFFFh, this is the Function Code of the command that is current executing. |
| 39:20 | Byte[20] | reserved | 00h | |
| 47:40 | Qword | LBA | | Current LBA of SCT command execution in background. If there is no command currently executing in the background, this field is undefined. |
| 199:48 | Byte[152] | | 00h | |
| 200 | Byte | HDA Temp | | Current HDA temperature in degrees Celsius. This is a 2's complement number. 80h indicates that this value is invalid. |
| 201 | Byte | Min Temp | | Minimum HDA temperature in degrees Celsius. This is a 2's complement integer. 80h indicates that this value is invalid. |
| 202 | Byte | Max Temp | | Maximum HDA temperature in degrees Celsius. This is a 2's complement number. 80h indicates that this value is invalid. |
| 203 | Byte | Life Min Temp | | Minimum HDA temperature in degrees Celsius seen for the life of the device. This is a 2's complement integer. 80h indicates that this value is invalid. |
| 204 | Byte | Life Max Temp | | Maximum HDA temperature in degrees Celsius seen for the life of the drive. This is a 2's complement number. 80h indicates that this value is invalid. |

Table 58 Data Format of SCT Status Response -1

| Byte | Type | Field Name | Value | Description |
|---------|-----------|-------------------|-------|---|
| 205 | Byte | Reserved | 00h | |
| 209:206 | Dword | Over Limit Count | | Number of temperature recording Intervals since the last power-on reset where the recorded temperature was greater than Max Op Limit. See table 93 for information about this Interval. |
| 213:210 | Dword | Under Limit Count | | Number of temperature recording Intervals since the last power-on reset where the recorded temperature was less than Min Op Limit. See table 93 for information about this Interval. |
| 479:214 | Byte[275] | Reserved | 00h | |
| 511:480 | Byte[32] | Vendor Specific | 00h | |

Table 59 Data Format of SCT Status Response -2

9.18.3 SCT Command Set

9.18.3.1 SCT Write Same (action code : 0002h)

Inputs: (Key Sector)

| Word | Name | Value | Description |
|--------|---------------|-------|---|
| 0 | Action Code | 0002h | This action writes a pattern or sector of data repeatedly to the media. This capability could also be referred to as “Write All” or “Write Same”. |
| 1 | Function Code | 0001h | Repeat Write Pattern (Background Operation) |
| | | 0002h | Repeat Write Sector (Background Operation) |
| | | 0101h | Repeat Write Pattern (Blocking Operation) |
| | | 0102h | Repeat Write Sector (Blocking Operation) |
| 5:2 | Start LBA | Qword | First LBA |
| 9:6 | Count | Qword | Number of sectors to fill |
| 11:10 | Pattern | Dword | If the Function Code is 0001h, this field contains a 32-bit pattern that is written on the media starting at the location specified in words two through five |
| 255:12 | reserved | 0000h | |

Table 60 SCT Write Same (Inputs)

Outputs: (TF Data)

| Command Block Input Registers (Success) | |
|---|---|
| Error | 00h |
| Sector Count | Reserved |
| Sector Number | Reserved |
| Cylinder Low | Number of sectors to transfer (LSB) = 01h |
| Cylinder High | Number of sectors to transfer (MSB) = 00h |
| Device/Head | Reserved |
| Status | 50h |

Table 61 Output Registers of SCT Write Same (Success)

The SCT Write Same command will begin writing sectors from Start LBA in incrementing order until Count sectors have been written. A Count of zero means apply operation from Start LBA until the last user LBA on the drive is reached. The HPA feature determines the last user LBA. This command will not write over a hidden partition when hidden partitions are enabled using the Host Protected Area drive capabilities. Automatic sector reassignment is permitted during the operation of this function.

If Start LBA or Start LBA + Count go beyond the last user LBA then an error is reported and the SCT command is not executed. Issuing this command with a value of zero for Start LBA and Count will cause all LBAs of the drive to be written the specified pattern.

Once the key sector has been issued, if the Function Code was 0002h or 0102h and the TF Data indicates that the drive is ready to receive data, log page E1h should be written to transfer the data.

This command can change the Segment Initialized Flag. If the command writes all the user addressable sectors and completes without encountering an error or being aborted, then the “Segment Initialized Flag” (bit 0 of the Status Flags in the SCT Status. See Table 58) shall be set to 1. A write to any user addressable sector on the drive

(except another complete write all), shall cause the Segment Initialized Flag to be cleared. Reallocations as a result of reading data (foreground or background) do not clear the Segment Initialized Flag.

Implementation note for Background Operation (Function code = 0001h, 0002h)

In this mode, the drive will return command completion status when the drive finished receiving data.

Any command, including IDENTIFY DEVICE, other than SCT Status, issued to the drive while this command is in progress will terminate the SCT Write Same command. The incoming command is executed.

Use the SCT Status command to retrieve status information about the current SCT command. Example status information includes: command active or complete, current LBA, and errors. When this command is in progress, the SCT status error code will be FFFFh, and set to 0000h if the command completes without error. It will be less than FFFFh and greater than 0000h if the command terminated prematurely for any reason.

| Possible Extended Status Code for Background Operation (Function code = 0001h, 0002h) | |
|---|--|
| 0008h | Background SCT command was aborted because of an interrupting host command |
| 0009h | Background SCT command was terminated because of unrecoverable error |
| FFFFh | SCT command executing in background |

Implementation note for Blocking Operation (Function code = 0101h, 0102h)

In this mode, the drive will return command completion status when the drive finished the SCT Write Same operation.

Outputs for Error

| Command Block Input Registers (Error) | | | | | | | | |
|---------------------------------------|----------------------------|---|---|---|---|---|---|---|
| Register | 7 | 6 | 5 | 4 | 3 | 2 | 1 | 0 |
| Error | 04h | | | | | | | |
| Sector Count | Extended Status code (LSB) | | | | | | | |
| Sector Number | Extended Status code (MSB) | | | | | | | |
| Cylinder Low | N/A | | | | | | | |
| Cylinder High | N/A | | | | | | | |
| Device/Head | - | - | - | - | - | - | - | - |
| Status | 51h | | | | | | | |

Table 62 Output Registers of SCT Write Same (Error)

| Possible Extended Status Code for Blocking Operation (Function code = 0101h, 0102h) | |
|---|---|
| 0017h | Blocking SCT Write Same command was terminated because of unrecoverable error |

9.18.3.2 Error Recovery Control Command (action code : 0003h)

Inputs: (Key Sector)

| Word | Name | Value | Description |
|-------|----------------|-------|---|
| 0 | Action Code | 0003h | Set the read and write error recovery time |
| 1 | Function Code | 0001h | Set New Value |
| | | 0002h | Return Current Value |
| 2 | Selection Code | 0001h | Read Timer |
| | | 0002h | Write Timer |
| 3 | Value | Word | If the function code is 0001h, then this field contains the recovery time limit in 100ms units. The minimum SCT timeout value is 65 (=6.5 second). When the specified time limit is shorter than 6.5 second, the issued command is aborted. |
| 255:4 | reserved | 0000h | |

Table 63 Error Recovery Control Command (Inputs)

Outputs: (TF Data)

| Command Block Input Registers (Success) | |
|---|--|
| Error | 00h |
| Sector Count | If Function Code was 0002h, then this is the LSB of the requested recovery limit. Otherwise, this field is reserved. |
| Sector Number | If Function Code was 0002h, then this is the MSB of the requested recovery limit. Otherwise, this field is reserved. |
| Cylinder Low | reserved |
| Cylinder High | reserved |
| Device/Head | reserved |
| Status | 50h |

Table 64 Error Recovery Control Command (On puts)

The Error Recovery Control command can be used to set time limits for read and write error recovery. For non-queued commands, these timers apply to command completion at the host interface. For queued commands where in order data delivery is enabled, these timers begin counting when the device begins to execute the command, not when the command is sent to the device. These timers do not apply to streaming commands, or to queued commands when out-of-order data delivery is enabled.

These command timers are volatile. The default value is 0 (i.e. disable command time-out).

If a Read Command Timer expires or a Write Command Timer expires before command completion, the device:

- a) Shall stop processing that command and return an error;
- b) Shall return an Uncorrectable Error, if that command was a read command;
- c) Should return command aborted, if that command was a write command; and
- d) Should set the EXTENDED STATUS CODE field to 0015h (see Table 53)

The EXTENDED STATUS CODE field shall be cleared during the processing of the next non-SCT command by the device, except if the command being processed is a read of the NCQ Command Error log.

9.18.3.3 Feature Control Command (action code : 0004h)

Inputs: (Key Sector)

| Word | Name | Value | Description |
|-------|---------------|-------|--|
| 0 | Action Code | 0004h | Set or return the state of drive features described in Table 67 |
| 1 | Function Code | 0001h | Set state for a feature |
| | | 0002h | Return the current state of a feature |
| | | 0003h | Return feature option flags |
| 2 | Feature Code | Word | See Table 67 for a list of the feature codes |
| 3 | State | Word | Feature code dependent value |
| 4 | Option Flags | Word | Bit15:1 = Reserved If the function code is 0001h, setting bit 0 to one causes the requested feature state change to be preserved across power cycles. If the function code is 0001h, setting bit 0 to zero causes the requested feature state change to be volatile. A hard reset causes the drive to revert to default, or last non-volatile setting. |
| 255:5 | reserved | 0000h | |

Table 65 Feature Control Command (Inputs)

Outputs: (TF Data)

| Command Block Input Registers (Success) | |
|---|---|
| Error | 00h |
| Sector Count | If Function Code was 0002h, then this is the LSB of Feature State. If Function Code was 0003h, then this is the LSB of Option Flags. Otherwise, this field is reserved. |
| Sector Number | If Function Code was 0002h, then this is the MSB of Feature State. If Function Code was 0003h, then this is the MSB of Option Flags. Otherwise, this field is reserved. |
| Cylinder Low | reserved |
| Cylinder High | reserved |
| Device/Head | reserved |
| Status | 50h |

Table 66 Feature Control Command (Outputs)

| Feature Code | State Definition |
|--------------|---|
| 0001h | <p>0001h : Allow write cache operation to be determined by Set Feature command 0002h : Force write cache enabled 0003h : Force write cache disabled</p> <p>If State 0001h is selected, the ATA Set Feature command will determine the operation state of write cache. If State 0002h or 0003h is selected, write cache will be forced into the corresponding operation state, regardless of the current ATA Set Feature state. Any attempt to change the write cache setting through Set Feature shall be accepted, but otherwise ignored, and not affect the operation state of write cache and complete normally without reporting an error.</p> <p>In all cases, bit 5 of word 85 in the Identify Device information will reflect the true operation state of write cache, one indicating enabled and zero indicating disabled. The default state is 0001h.</p> |
| 0002h | <p>0001h : Enable Write Cache Reordering 0002h : Disable Write Cache Reordering</p> <p>The default state is 0001h. The drive does not return error for setting state 0002h, but the state is ignored.</p> |
| 0003h | <p>Set time interval for temperature logging. 0000h is invalid. 0001h to FFFFh logging interval in minutes.</p> <p>This value applies to the Absolute HDA Temperature History queue. Issuing this command will cause the queue to be reset and any prior values in the queue will be lost. Queue Index shall be set to zero and the first queue location will be set to the current value. All remaining queue locations are set to 80h. The Sample Period, Max Op Limit, Over Limit, Min Op Limit and Under Limit values are preserved. Default value is 0001h.</p> |
| 0004h-CFFFh | Reserved |
| D000h-FFFFh | Vendor Specific |

Table 67 Feature Code List

9.18.3.4 SCT Data Table Command (action code : 0005h)

Inputs: (Key Sector)

| Word | Name | Value | Description |
|-------|---------------|-------|--|
| 0 | Action Code | 0005h | Read a data table |
| 1 | Function Code | 0001h | Read Table |
| 2 | Table ID | Word | See Table 70 for a list of data tables |
| 255:2 | reserved | 0000h | |

Table 68 SCT Data Table Command (Inputs)

Outputs: (TF Data)

| Command Block Input Registers (Success) | |
|---|---|
| Error | 00h |
| Sector Count | reserved |
| Sector Number | reserved |
| Cylinder Low | Number of sectors to transfer (LSB) = 01h |
| Cylinder High | Number of sectors to transfer (MSB) = 00h |
| Device/Head | reserved |
| Status | 50h |

Table 69 SCT Data Table Command (Outputs)

| Table ID | Description |
|-------------|--|
| 0000h | Invalid |
| 0001h | Reserved |
| 0002h | HDA Temperature History Table (in absolute degree C). See Table 72 |
| 0003h-CFFFh | Reserved |
| D000h-FFFFh | Vendor Specific |

Table 70 Table ID and Descriptions

| Byte | Size | Field Name | Description |
|-------|----------|-----------------|--|
| 1:0 | Word | Format Version | Data table format version (=0002h) |
| 3:2 | Word | Sampling Period | Absolute HDA Temperature sampling period in minutes. 0000h indicates sampling is disabled. |
| 5:4 | Word | Interval | Timer interval between entries in the history queue. |
| 6 | Byte | Max Op Limit | Maximum recommended continuous operating temperature. This is a one byte 2's complement number that allows a range from -127°C to +127°C to be specified. 80h is an invalid value. This is a fixed value. |
| 7 | Byte | Over Limit | Maximum temperature limit. This is a one byte 2's complement number that allows a range from -127°C to +127°C to be specified. 80h is an invalid value. This is a fixed value. |
| 8 | Byte | Min Op Limit | Minimum recommended continuous operating limit. This is a one byte 2's complement number that allows a range from -127°C to +127°C to be specified. 80h is an invalid value. This is a fixed value. |
| 9 | Byte | Under Limit | Minimum temperature limit. This is a one byte 2's complement number that allows a range from -127°C to +127°C to be specified. 80h is an invalid value. This is a fixed value. |
| 29:10 | Byte[20] | Reserved | |
| 31:30 | Word | Queue Size | Number of entry locations in history queue. This value is 128. |
| 33:32 | Word | Queue Index | Last updated entry in queue. Queue Index is zero-based, so Queue Index 0000h is the first location in the buffer (at offset 34). The most recent temperature entered in the buffer is at Queue Index + 34. See Note 1 and Note 2. |

Table 71 Data Format of HDA Absolute Temperature History Table -1

| Byte | Size | Field Name | Description |
|-------------------------|-----------------------------|--------------|--|
| (Queue Size+33):34 | Byte[Queue Size] | Queue Buffer | <p>This is a circular buffer of absolute HDA Temperature values. These are one byte 2's complement numbers, which allow a range from -127°C to +127°C to be specified. A value of 80h indicates an initial value or a discontinuity in temperature recording.</p> <p>The Actual time between samples may vary because commands may not be interrupted. The sampling period is the minimum time between samples. See Note 1.</p> <p>If the host changes the logging interval using the volatile option, the interval between entries in the queue may change between power cycles with no indication to the host.</p> |
| 511 (Queue Size +34) | Byte [512-Queue Size-34] | Reserved | |

Note 1 – The Absolute HDA Temperature History is preserved across power cycles with the requirement that when the drive powers up, a new entry is made in the history queue of 80h, an invalid absolute temperature value. This way an application viewing the history can see the discontinuity in temperature result from the drive being turned off.

Note 2 – When the Absolute HDA Temperature history is cleared, for new drives or after changing the Logging Interval, the Queue Index shall be set to zero and the first queue location shall be set to the current Absolute HDA Temperature value. All remaining queue locations are set to 80h.

Table 72 Data Format of HDA Absolute Temperature History Table -2

9.19 Extended Power Conditions (EPC) Feature

The Extended Power Conditions feature set provides a host with additional methods to control the power condition of a device.

Subcommand code 4Ah enables, disables, and configures the use of the Extended Power Conditions feature set. If the EPC feature set is not supported, then the device return command aborted Table 73 describes the EPC subcommands and Table 74 describes the power condition IDs.

| EPC Subcommand | Description |
|----------------|----------------------------------|
| 0h | Restore Power Condition Settings |
| 1h | Go To Power Condition |
| 2h | Set Power Condition Timer |
| 3h | Set Power Condition State |
| 4h | Enable the EPC feature |
| 5h | Disable the EPC feature |
| 6h ... Fh | Reserved |

Table 73 Extended Power Conditions Subcommands

| Power Condition ID | Power Condition Name | Description |
|--------------------|----------------------|------------------------------------|
| 00h | standby_z | Standby |
| 01h | standby_y | Low RPM Idle |
| 02h...80h | | Reserved |
| 81h | idle_a | Active Idle |
| 82h | idle_b | Low Power Idle |
| 83h | idle_c | Low RPM Idle |
| 84h ... FEh | | Reserved |
| FFh | All | All supported EPC power conditions |

Table 74 Power Condition IDs

9.19.1 Power Conditions

idle_a, idle_b and idle_c are power conditions within the PM1:Idle power management state. standby_y and standby_z are power conditions within the PM2:Standby power management state. Please refer to ACS-2 "3.1 Definitions and abbreviations" about PM1:Idle and PM2:Standby. The power conditions are ordered from highest power consumption (i.e., shortest recovery time) to lowest power consumption (i.e., longest recovery time) as follows:

idle_a power >= idle_b power >= idle_c power >= standby_y power >= standby_z power

Each of these power conditions has a set of current, saved and default settings. Default settings are not modifiable. Default and saved settings persist across power cycles. The current settings do not persist across power cycles.

9.19.2 Power Condition Timers

The device has manufacturer specified power-on default settings for the power condition timers. Power condition timers are changeable with the SET FEATURES Extended Power Conditions subcommand.

A power condition timer set to zero indicates that the associated power condition is disabled.

If the power condition is enabled, then the value of each timer specifies the time after command completion that the device waits before transitioning to the power condition. All enabled power condition timers run concurrently.

On command completion all timers that were stopped are initialized with the Current Timer settings values and started.

As a result of processing any command, the device may change to a different power condition.

If an enabled timer associated with a power condition lower than the power condition that the device is currently in expires, then the device transitions to the power condition associated with that timer (e.g., if the standby_z timer is set to a smaller interval than the idle_b timer, and the device is currently in the standby_z power condition, then the device remains in the Standby_z power condition when the idle_b timer expires). If the timer expiration qualifies the device to transition to more than one enabled power condition, then the device transitions to the power condition with the least power consumption.

If a command is accepted that requires a transition to Active, then the timers are stopped. If a command is accepted that does not require a transition to Active (e.g., a CHECK POWER MODE command), then the timers continues to run.

Prior to entering into any power condition that prevents accessing the media (e.g., before a hard drive stops its spindle motor during transition to the standby_z power condition) and if volatile write cache is enabled, then the device shall write all cached data to the medium for the device (e.g., as a device does in response to a flush command).

9.19.3 Interaction with Resets, Commands and Other Features

On successful processing of a power cycle, the EPC enables sub command, the device:

When EPC is Enabling, the following content is executed.

- 1) stop all EPC timers.
- 2) copy the Saved Timer Enabled field to the Current Timer Enabled field, for all supported power conditions.
- 3) copy the Saved Timer Settings field to the Current Timer Settings field, for all supported power conditions.
- 4) initialize and restart all enabled EPC timers with Current values.

On successful processing of a hardware reset, a software reset, or a DEVICE RESET command, the device:

When EPC is Enabling, the following content is executed.

- 1) stop all EPC timers.
- 2) remain in the current power condition.
- 3) initialize and restart all enabled EPC timers with Current values.

The Extended Power Conditions feature set and the Advanced Power Management feature set are mutually exclusive. All EPC subcommands, except Enable the EPC feature set, returns command aborted if the EPC feature set is disabled. If the device processes a SET FEATURES Enable APM subcommand without error and IDENTIFY DEVICE data word 120 bit 7 is set to one, then the device shall disable the EPC feature set.

During background activities, all EPC timers are stopped. On completion of the activity, any stopped EPC timers be continued from where they were paused.

9.20 Sanitize Device Feature Set

9.20.1 Overview

The Sanitize Device Feature Set allows hosts to request that devices modify the content of all user data areas in the device using sanitize operations. Sanitize operations use one of the operations defined in this sub clause to make all previously written content in the user data area of the device unable to be read. Sanitize operations affect the following:

- a) user data areas
- b) user data areas that are not currently allocated (e.g., previously allocated areas and physical sectors that have become inaccessible)
- c) user data caches

Sanitize operations render user data previously stored in caches, using any methods, unable to be read.

The Sanitize Device feature set is implemented, the following commands are supported:

- a) SANITIZE STATUS EXT
- b) SANITIZE FREEZE LOCK EXT
- c) CRYPTO SCRAMBLE EXT
- d) OVERWRITE EXT

If physical sectors that have become inaccessible are not successfully sanitized, then Sanitize operations don't cause a transition to the SD3: Sanitize Operation Failed state.

Sanitize operations don't affect non-user data areas (e.g., logs, and Device SMART data structure).

Sector reallocation is able to be performed during the operation of this function. After completion of a sanitize operation, if:

- a) all physical sectors that are available to be allocated for user data have been successfully sanitized
- b) any physical areas that were not successfully sanitized were removed from use,

then:

- a) the Sanitize Device state machine transitions to SD4: Sanitize Operation Succeeded; and
- b) in subsequent SANITIZE STATUS EXT commands, set the SANITIZE OPERATION COMPLETED WITHOUT ERROR bit to one in the Normal Outputs

Conversely, if physical sectors that are available to be allocated for user data (e.g. allocated physical sectors) were not successfully sanitized, then:

- a) the Sanitize Device state machine transitions to SD3: Sanitize Operation Failed; and
- b) in subsequent SANITIZE STATUS EXT commands, return an error and set the LBA field of the Error Outputs to report the value of Sanitize Command Unsuccessful

To initiate a sanitize operation the host issues one of the following sanitize operation commands:

- a) A CRYPTO SCRAMBLE EXT command
- b) An OVERWRITE EXT command

The sanitize operation continues after command completion of the initiating sanitize operation command. The SANITIZE STATUS EXT command reports progress and completion.

After a device has started processing a sanitize operation, and until the device transitions to the SD0:

Sanitize Idle state, the device aborts all commands other than:

- a) IDENTIFY DEVICE command
- b) IDLE IMMEDIATE command with UNLOAD feature
- c) Request Sense Data Ext command;
- d) SANITIZE STATUS EXT command;
- e) SMART READ LOG command requesting log address E0h;
- f) READ LOG EXT command requesting one of the following log addresses:
 - A) E0h;

- B) 30h; or
- C) 10h;
- g) READ LOG DMA EXT command requesting one of the following log addresses:
 - A) E0h;
 - B) 30h; or
 - C) 10h;
- h) SMART RETURN STATUS command; or
- i) SET FEATURES PUIS feature set device spin-up subcommand.

If a sanitize operation is interrupted by a power-on reset, the sanitize operation continues. If the device processes a power-on reset and enters the PM5: PUIS and spin-up subcommand not supported state (see Figure 14), then the device resumes processing the sanitize operation after receiving a media access command. (The media access command reports failure because the sanitize operation does not allow media access commands. However, since the device has received a media access command, the device is spin-up.)

The SANITIZE STATUS EXT command returns information about the current sanitize operation, if any, including a percentage of completion if a sanitize operation is in progress.

A CRYPTO SCRAMBLE EXT command, or OVERWRITE EXT command that returns command completion with no error transitions the device into the SD2: Sanitize Operation state. The device remains in this state until the device has completed the sanitize operation (see figure 9).

The SANITIZE FREEZE LOCK EXT command causes the device to transition to the SD1: Sanitize Frozen state and causes any subsequent CRYPTO SCRAMBLE EXT command or OVERWRITE EXT command to be aborted. If the device processes a power-on reset or a hardware reset, then the device transitions from the Sanitize Frozen state to the Sanitize Idle state.

The crypto scramble operation makes previously written contents in the user data area irretrievable.

The overwrite operation fills all user data with a four byte pattern passed within the LBA field of the command. Parameters for the OVERWRITE EXT command include a count for multiple overwrites and the option to invert the four byte pattern between consecutive overwrite passes.

A software reset does not cause the SD2: Sanitize Operation state to transition to another state.

9.20.2 Sanitize Device Feature

The Sanitize Device Feature Set is a powerful data erase feature. Two data erase features are supported. One is an Overwrite Ext command, and the other is Crypto Scramble Ext command. The Crypto Scramble Ext command is only available on data encryption models.

Individual Sanitize Device commands are identified by the value specified in the FEATURE field.

The following commands are supported for this feature.

| Command | COMMAND field value | FEATURE field value |
|---------------------------------|---------------------|---------------------|
| SANITIZE STATUS EXT | ('B4'h) | ('0000'h) |
| CRYPTO SCRAMBLE EXT | ('B4'h) | ('0011'h) |
| OVERWRITE EXT | ('B4'h) | ('0014'h) |
| SANITIZE FREEZE LOCK EXT | ('B4'h) | ('0020'h) |

9.20.3 Sanitize Device State Machine

Figure 14 describes the operation of the Sanitize Device state machine.

9.20.3.1 SD0: Sanitize Idle State

In SD0: Sanitize Idle state the Sanitize Device state machine is ready for a sanitize operation command or a SANITIZE FREEZE LOCK EXT command.

This state is entered when the device processes a power-on reset while in the SD1: Sanitize Freeze Lock state or the SD4: Sanitize Operation Succeeded state.

While in this state, Sanitize Device state machine does not change state if the device processes:

- a) a hardware reset or power-on reset
- b) a SANITIZE STATUS EXT command.

Transition SD0:SD1: If the device processes a SANITIZE FREEZE LOCK EXT command, then the device transitions to the SD1: Sanitize Frozen state.

Transition SD0:SD2: If the device successfully processes a supported sanitize operation command, then the device transitions to the SD2: Sanitize Operation state.

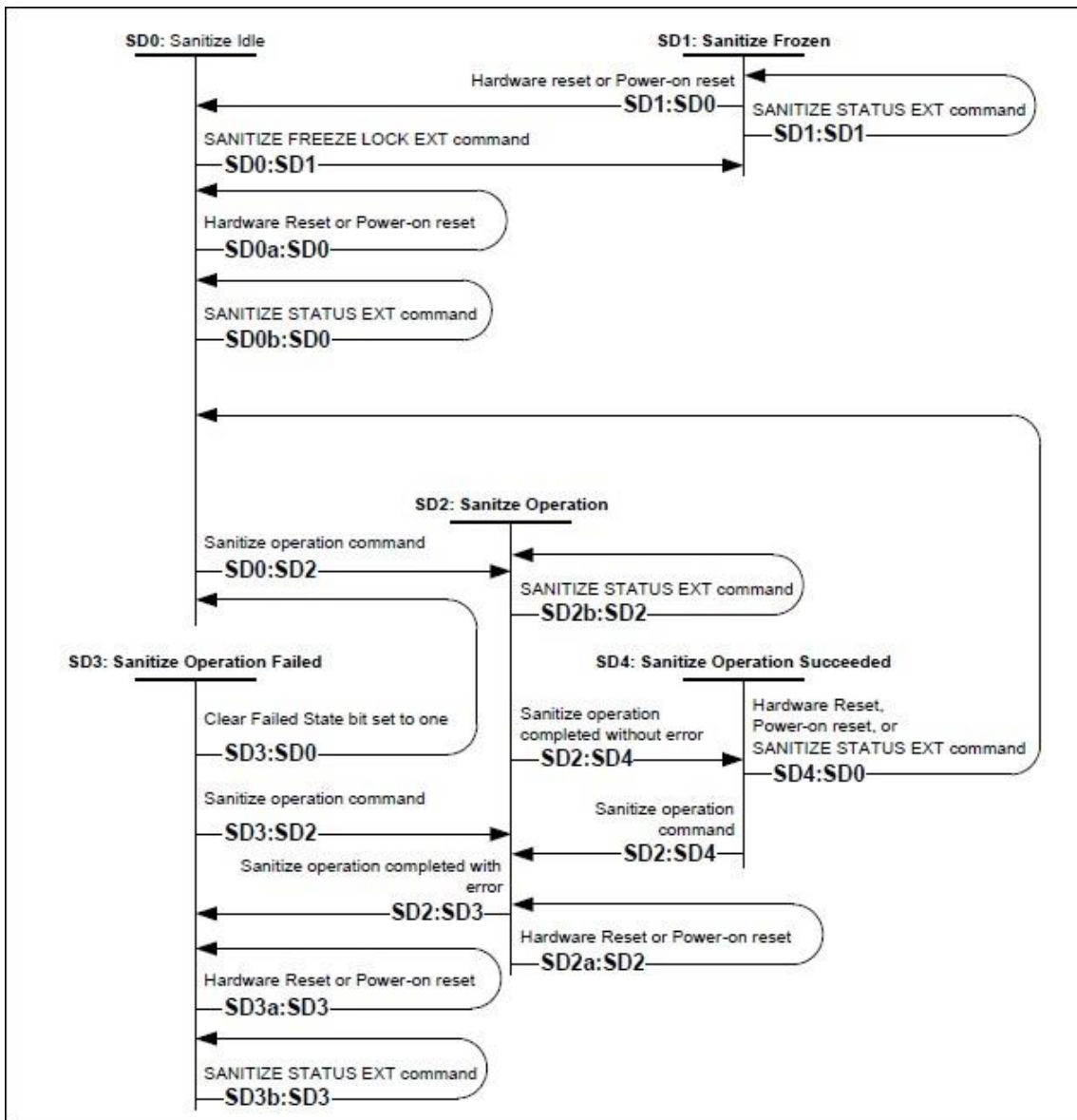

Figure 14 Sanitize Device State Machines

9.20.3.2 SD1: Sanitize Frozen State

In SD1: Sanitize Frozen state, the device will abort Sanitize operation commands.

While in this state, Sanitize Device state machine does not change state if the device processes a SANITIZE STATUS EXT command.

Transition SD1:SD0: If the device processes a hardware reset or a power-on reset, then the device transitions to the SD0: Sanitize Idle state.

9.20.3.3 SD2: Sanitize Operation State

In the SD2: Sanitize Operation state, the device is processing a sanitize operation.

While in this state, Sanitize Device state machine does not change state if the device processes:

- a) a hardware reset or power-on reset; and
- b) a SANITIZE STATUS EXT command.

Transition SD2:SD3: If a sanitize operation completes with an error, then the device transitions to the SD3: Sanitize Operation Failed state.

Transition SD2:SD4: If a sanitize operation completes without an error, then the device transitions to the SD4: Sanitize Operation Succeeded state.

9.20.3.4 SD3: Sanitize Operation Failed State

In the SD3: Sanitize Operation Failed state, the device has completed processing a sanitize operation without success.

While in this state, Sanitize Device state machine does not change state if the device processes:

- a) a hardware reset or power-on reset; and
- b) a SANITIZE STATUS EXT command with the CLEAR SANITIZE OPERATION FAILED bit cleared to zero.

Transition SD3:SD0: If

- a) the Sanitize operation was initiated by a Sanitize operation command with the FAILURE MODE bit set to one; and
- b) the SANITIZE STATUS EXT command has been successfully processed with the CLEAR SANITIZE OPERATION FAILED bit set to one,

then the device transitions to the SD0: Sanitize Idle state.

Transition SD3:SD2: If the device processes a supported sanitize operation command that reports command completion with no error, then the device transitions to the SD2: Sanitize Operation state.

9.20.3.5 SD4: Sanitize Operation Succeeded State

In the SD4: Sanitize Operation Succeeded state, the device has completed processing a successful sanitize operation.

Transition SD4:SD0: If the device processes

- a) a hardware reset;
- b) a power-on reset; or
- c) a SANITIZE STATUS EXT command

then the device transitions to the SD0: Sanitize Idle state.

Transition SD4:SD2: If the device successfully processes a supported Sanitize operation command, then the device transitions to the SD2: Sanitize Operation state.

9.21 Trusted Computing Group Feature Set

This chapter provides information on WDC encryption-specific HDD firmware and features. It is assumed that the reader is familiar with the referenced specifications and industry standards.

9.21.1 Referenced Specifications and Standards

9.21.1.1 TCG Specifications

This section references 3 separate TCG specifications, which are available on the TCG website:

(<http://www.trustedcomputinggroup.org/>):

1. TCG Core Specification, Version 2.00, Revision 1.00 (4/20/2009)
 - The TCG Core Specification is the general specification for trusted computing that encompasses all classes of devices, including storage
2. TCG Storage Interface Interactions Specification (SIIF), Version 1.0, 1/27/2009
 - Specifies the interaction between the HDD and the SCSI/ATA protocols
3. TCG Storage Security Subsystem Class (SSC): Enterprise, Version 1.00, rev 3.00 (1/10/2011)
 - A Security Subsystem Class defines minimum acceptable Core Specification capabilities of a storage device in a specific class (in our case – enterprise).
 - Storage devices in specific classes may have a subset of the capabilities that are defined in the core specification
4. TCG Storage Security Subsystem Class: Opal Specification, Version 2.00 Final Revision 1.00 (February 24, 2012)

9.21.1.2 Federal Information Processing Standards (FIPS)

This section references the following Federal Information Processing Standards, published by the US National Institute of Standards (NIST), which are available on the NIST website

(<http://csrc.nist.gov/publications/PubsFIPS.html>):

1. FIPS 197, Advanced Encryption Standard (AES), 2001 November 26.
<http://nvlpubs.nist.gov/nistpubs/FIPS/NIST.FIPS.197.pdf>
2. FIPS 186-4, Digital Signature Standard (DSS), 2013, July
<http://nvlpubs.nist.gov/nistpubs/FIPS/NIST.FIPS.186-4.pdf>
3. FIPS 180-4, Secure Hash Standard (SHS), 2015 August
<http://nvlpubs.nist.gov/nistpubs/FIPS/NIST.FIPS.180-4.pdf>

9.21.1.3 National Institute of Standards (NIST)

This section references the following NIST publications, available on the NIST website

(<http://csrc.nist.gov/publications/index.html>)

- [AES] Advanced Encryption Standard, FIPS PUB 197, NIST, 2001, November
- [DSS] Digital Signature Standard, FIPS PUB 186-4, NIST, 2013 July
- [HMAC] The Keyed-Hash Message Authentication Code, FIPS PUB 198-1, 2007 June
- [SHA] Secure Hash Standard (SHS), FIPS PUB 180-4, NIST, 2015 August
- [SP800-38E] Recommendation for Block Cipher Modes of Operation: The XTS-AES Mode for Confidentiality on Storage Devices, SP800-38E, NIST, 2010 January
- [SP800-38F] Recommendation for Block Cipher Modes of Operation: Methods for Key Wrapping, NIST, 2012 December
- [SP800-57] Recommendation for Key Management – Part I General (Revision 3), NIST, 2012 July
- [SP800-90A] Recommendation for Random Number Generation Using Deterministic Random Bit Generators, (Revision 1), NIST, 2015 November

- [SP800-131A] Transitions: Recommendation for Transitioning the Use of Cryptographic Algorithms and Key Lengths, NIST, 2011 Jan
- [SP800-132] Recommendation for Password-Based Key Derivation, NIST, 2010 December

9.21.1.4 Department of Defense

DoD 5220.22-M, "National Industrial Security Program Operating Manual", 2/28/2006
<http://www.esd.whs.mil/Portals/54/Documents/DD/issuances/dodm/522022M.pdf>

9.21.1.5 RSA Laboratories Standards

1. RSA-PSS - <https://www.emc.com/collateral/white-papers/h11300-pkcs-1v2-2-rsa-cryptography-standard-wp.pdf>
2. RSA PKCS #5 v2.0 Password-Based Cryptography Standard - <https://www.emc.com/collateral/white-papers/h11302-pkcs5v2-1-password-based-cryptography-standard-wp.pdf>

9.21.2 Implementation Exceptions

The following is a list that describes non-compliance with the TCG Enterprise SSC specification:

- The SSC specification requires support for 1023 bands, but the implementation supports up to 15 bands.
- The K_AES_256 table was implemented with only the **UID** and **MODE** columns.
- Only one active session is permitted at a time. If a new session is requested when a session is already active, the drive answers the host with SP_BUSY, instead of NO_SESSIONS_AVAILABLE

9.21.3 Implementation Features and Details Outside of TCG Specifications

The following features are outside of the TCG specifications.

1. Ports
2. Firmware signing

The following implementation details are outside of the TCG Enterprise SSC specification.

- a. The SSC Specification states "The TPer SHALL implement the ParamCheck Longitudinal Redundancy Check (LRC) for Get and Set method calls on a PIN value". If the LRC check is erroneously applied to a value other than a PIN we ignore it, therefore no error is generated.
- b. When handling a "TCG cmd followed by a R/W cmd", all reads and writes that follow a TCG command will be processed in the normal way. No special handling or error messages will be sent to the host. It is up to the host to understand the possible outcomes of TCG commands and r/w command ordering and plan accordingly.
- c. CRC checking is disabled in all cases, so the drive will return data to the host. If the user successfully authenticates, then unencrypted data is returned to the host. If the user is unable to authenticate, encrypted data is returned to the host.
- d. The TPer replies with SP_BUSY for requests beyond 1 session.
- e. TCG Life Cycle Model by Activate Method and Revert Method was implemented by according to Opal SSC

9.21.4 Encryption Algorithms

9.21.4.1 Advanced Encryption Standard (AES) Support

AES encryption is implemented in hardware, with support for ECB or XTS mode for 128 bit or 256 bit keys.

A single key is active at any one time within the AES hardware engine. Firmware is responsible for reading the keys from the hardware and also for determining which key is attached to a given LBA range; the hardware can only detect if the LBA has been encrypted or not. The TCG protocol does not allow for a user to choose or switch between AES algorithms, so it is up to the vendor to choose which AES algorithm is used in their implementation. The WDC TCG Enterprise SSC implementation in firmware supports AES 256-XTS only.

The AES hardware implementation used for the range encryption has received the FIPS 197 certification by the US National Institute of Standards (NIST), which are available on the NIST CAVP website, (<http://csrc.nist.gov/groups/STM/cavp/documents/aes/aesval.html>. Validation No. 3880 and 3881):

9.21.4.2 ‘Level 0 Discovery’ Vendor Specific Data

This section refers to section 3.6.2 of the TCG Storage Security Subsystem Class document (see the Specifications section of this document). This Vendor Specific section is documented below.

| Byte | Bit | | | | | | | |
|-------|-----------------------------------|------|---|---|--------|---------|-----------|-------|
| | 7 | 6 | 5 | 4 | 3 | 2 | 1 | 0 |
| 16 | Version (set to 0) | | | | | | | |
| 17 | Vendor Specific State Information | | | | | | | |
| 18 | Reserved | | | | | | | |
| 19 | RSVD | MB_s | 0 | 0 | Diag_s | Dload_s | Locking_s | FDE_s |
| 20 | Reserved | | | | | | | |
| 21 | RSVD | MB_e | 0 | 0 | Diag_s | Dload_e | Locking_e | FDE_e |
| 22 | 0 | 0 | 0 | 0 | 0 | 0 | 0 | 0 |
| 23-47 | Reserved | | | | | | | |

Table 75 Vendor Specific Data for Level 0 Discovery

FDE_s/FDE_e - Full disk encryption is Supported (equivalent to Media Encryption in Locking Feature Descriptor Enterprise SSC 3.6.2.5) / Full disk encryption is Enabled on one or more band.

Locking_s/Locking_e - LBA band locking is supported - locking object exists in the locking SP of the device (equivalent to Locking Enabled in Locking Feature Descriptor Enterprise SSC 3.6.2.5) / The locking object for a band has either ReadLocked or WriteLocked attribute set (equivalent to Locked in Locking Feature Descriptor Enterprise SSC 3.6.2.5).

Dload_s/Dload_e - support for Admin SP Firmware download port / Firmware download port via Admin SP is locked.

Diag_s/Diag_e - Support for Admin SP vendor specific Diagnostic port / Diagnostics port via Admin SP is locked.

MB_s/MB_e - Multiple encrypting bands supported / multiple encrypting bands enabled. This bit shall be set to 1 if more than one band exists in addition to the global band and is defined with at least one LBA.

9.21.4.3 Deterministic Random Bit Generation (DRBG)

Pseudo-random number generation is implemented with a certified NIST SP800-90A DRBG. The DRBG uses AES as a primitive for both entropy mixing and entropy output. DRBG state is kept private to ensure that the keys that are generated by the device are unpredictable. The entropy source of the DRBG is servo subsystem noise. It has been verified to NIST SP800-90B.

9.21.4.4 Key Wrap

The NIST SP800-38F key wrap algorithm is used to encrypt a key with another key (KEK= Key Encryption Key). For any band *i*, the KEK_{*i*} is derived from PIN_{*i*} and salt_{*i*} using the NIST 800-132 algorithm. The KEK_{*i*} is then used to wrap a band's encryption key.

9.21.4.5 Key Erasure

Cryptographic erase procedure

- Erase and overwrite wrapped key material with 0x00.
- Erase and store the new wrapped key material.

9.21.5 TCG Enterprise SSC Tables

Two copies of all TCG Enterprise SSC tables and data structures are stored in the RID; one is used as a primary copy and the other as a backup copy. The backup copy is used in the event the primary copy becomes corrupted. Each time a write is executed to any TCG table, both the primary and backup copies of the tables are updated and saved in the RID. In the case of a corrupted copy, the good copy is always used to restore the corrupted copy to the correct state. If both copies of the tables become corrupted during operation, the tables will be reinitialized to default values automatically, and this will result in a key mismatch error when a read is attempted.

The default values in the TCG tables created at the time of manufacturing are per the TCG Enterprise SSC specification. The following tables contain VU (Vendor Unique) entries, which are set at the time of manufacturing.

- 'Admin SP' C_PIN table
- 'Locking SP' C_PIN table
- K_AES_256 table
- 'Locking SP' Locking Access Control table
- 'Locking Info' Table
- 'Locking SP' Locking Table

The VU entries for these tables are specified below. In addition, explanation of default values is given for non-VU entries that require it.

9.21.5.1 'Admin SP' C_PIN and 'Locking SP' C_PIN Tables

Per TCG Enterprise SSC specification, the PIN is set to the MSID at manufacturing time. WDC has specified the MSID to be the serial number of the drive concatenated 4x. Try Limit is set to 0, meaning that there is no limit. Tries is set 0, meaning that there have been no fail attempts. Persistence is set to 0, meaning the "Tries" value does not persist through power cycles (The "Tries" value is reset to 0 after successful attempt or a power cycle).

| PIN | Try Limit | Tries | Persistence |
|------|-----------|-------|-------------|
| SID | 0 | 0 | 0 |
| MSID | 0 | 0 | 0 |

Table 76 WDC Default Values for 'Admin SP' C_PIN & 'Locking SP' C_PIN

9.21.5.2 K_AES_256 Table

The K_AES_256 table has 16 rows, one row for each band that can be allocated by the user. The first row is for the “global range”, also known as Band 0. This table was implemented without the “Name”, “Common Name”, and “Key” Columns.

| UID (8 byte hex) | MODE |
|-------------------------|------|
| 00 00 08 06 00 00 00 01 | 23 |
| 00 00 08 06 00 00 00 02 | 23 |
| .. | .. |
| 00 00 08 06 00 00 00 10 | 23 |

Table 77 WDC Implementation of K_AES_256 Table

The mode is specified in the TCG Enterprise SSC as a “Vendor Unique” (VU) entry. WDC initializes it in manufacturing to **mode=23** (media encryption mode, per TCG specification) for all 64 entries.

9.21.5.3 ‘Locking SP’ Access Control Table

The TCG Enterprise SSC defines the values for Row Number and UID as “Vendor Unique” (VU). WDC has defined them to be the row number in the table, with a range of 0-459. The range is calculated using the following formula:

number_of_rows = (#Supported Bands * 7) + 12, where

- #Supported Bands = 16 (The implementation supports 15 bands and Band 0)
- The number 7 comes from the fact that each band has 7 UID/method combinations
- The number 12 comes from the following 12 methods that must be included in the table.
 1. ThisSP / Authenticate
 2. Authority Table/Next
 3. Anybody Authority Object/ Get
 4. Band Masters Authority Object/ Get
 5. Erase Master Auth. Object / Get
 6. C_PIN table / Next
 7. Erase Master C_PIN Object/ Set
 8. Locking Info Table / Get
 9. Locking Table / Next
 10. DataStore / Get
 11. DataStore / Set
 12. ThisSP / Random

| Row Number | UID |
|------------|-----|
| 0 | 0 |
| 1 | 1 |
| ... | ... |
| 124 | 124 |

Table 78 WDC Implementation of ‘Locking SP’ Access Control Table

9.21.5.4 ‘Locking Info’ Table

As specified in the TCG Enterprise SSC, this table has only 1 row. The “Vendor Unique” entries are specified in the table below. Encryption Support is initialized to **Encryption Support=23** (media encryption mode) in manufacturing.

| NAME | Version | Encrypt Support | Max Ranges | Max ReEncryptions | Keys Available Cfg |
|------|---------|-----------------|------------|-------------------|--------------------|
| 0 | 0 | 23 | 6 | 0 | 0 |

Table 79 WDC Implementation of ‘Locking Info’ Table

9.21.5.5 ‘Locking SP’ Locking Table

The “Vendor Unique” (VU) values for this table are shown below.

| Next Key | ReEncrypt State | ReEncrypt Request | Adv Key Mode | Verf Mode | Cont On Reset | Last ReEncrypt LBA | Last Re Enc Stat | General Status |
|-----------------------------|-----------------|-------------------|--------------|-----------|---------------|--------------------|------------------|----------------|
| 00 00 00 00 00 00 00 00h | 0 | 0 | 0 | 0 | 0 | 0 | 0 | 0 |
| - | - | - | - | - | - | - | - | - |
| 00 00 00 00 00 00 00 05h | 0 | 0 | 0 | 0 | 0 | 0 | 0 | 0 |

Table 80 WDC Implementation of ‘Locking SP’ Locking Table

In the **ActiveKey** column, the Enterprise SSC allows for byte 3 to be defined as either 05 or 06. The WDC implementation uses 06.

9.21.6 Firmware Download and Signing

Digitally signed WDC Firmware downloaded to WDC branded drives provides a mechanism for secure updates through the Host interface. Firmware is downloaded to the drive through the host interface, and the signature is verified using a public key installed in the reserved area during manufacturing, before it is loaded to RAM or installed in the reserved area on the HDD.

Signature verification uses the RSA-PSS (Probabilistic Signature Scheme) signature verification algorithm with EMSA-SHA256 as padding function.

All WDC firmware packages are signed. All WDC branded drives verify the signature. If the signature fails to verify, WDC branded drives reject the downloaded firmware package. Failures to authenticate the firmware image will result in Check Condition with KCQ 5/26/9a (FRU 0). The act of issuing a firmware download to the drive will result in an implicit close of all open sessions at the security layer.

9.21.7 Ports

The ports capability is a WDC feature which is not a requirement under TCG Enterprise SSC. In order to use the ports capabilities on encryption drives, the user must successfully authenticate. Once a user successfully authenticates, they may change the state of any of the ports at any time during an active session to either the locked or unlocked state. The functionality and definition of these ports is shown below in a table.

The feature does make use of the TCG structures and tables. An additional table, the ports table, has been implemented, and additional entries were made to the Admin SP ACE table and the Admin SP AccessControl Table. The ports table and the modified TCG Enterprise SSC tables are shown below.

| Port Name | Description |
|-------------------|---|
| Firmware Download | This port has 2 valid states: locked and unlocked. On encryption drives, the download port is unlocked initially, Lock On Reset is "Null". Code can be downloaded onto the drive after the signature is successfully verified. If the signature cannot be verified successfully, no firmware can be downloaded to the drive. The user can change the state of the firmware download port only after authentication. On non-encryption drives, this port will be set to unlocked at the factory, and the state cannot be changed by the user. The digital signature of all firmware downloaded to the non-encryption drive through this port is verified by the drive. |
| Diagnostics | This port has 2 valid states: locked and unlocked. This port allows WDC access to modify any TCG table or key. In order to open this port both the SID and the Maker authorities need to be authenticated. The purpose of this port is to aid WDC in debugging |

Table 81 Ports Functionality

| UID | Name | LockOnReset | PortLocked |
|-------------------------|---------------------|-------------|------------|
| 00 01 00 02 00 01 00 02 | Firmware_Dload_Port | Null | FALSE |
| 00 01 00 02 00 01 00 01 | Diagnostic_Port | PowerCycle | TRUE |

Table 82 Ports Table

| UID | Name | Comn Name | Boolean Expression | Row Start | Row End | Column Start | Column End |
|----------------------------|------------------------|-----------|---|-----------|---------|---------------|--------------|
| 00 00 00 08 00 00 00 01 | Anybody | "" | 00 00 00 09 00 00 00 01 | Null | Null | "" | "" |
| 00 00 00 08 00 00 00 03 | Makers | "" | 00 00 00 09 00 00 00 03 | Null | Null | "" | "" |
| 00 00 00 08 00 00 02 01 | SID | "" | 00 00 00 09 00 00 00 06 | Null | Null | "" | "" |
| 00 00 00 08 00 00 8C 03 | SID_SetSelf | "" | 00 00 00 09 00 00 00 06 | Null | Null | "PIN" | "PIN" |
| 00 00 00 08 00 00 8C 04 | MSID_Get | "" | 00 00 00 09 00 00 00 01 | Null | Null | "PIN" | "PIN" |
| 00 00 00 08 00 00 8C 05 | SID_Set Makers | "" | 00 00 00 09 00 00 00 06 | Null | Null | "Enabled" | "Enabled" |
| 00 00 00 08 00 00 8C 06 | SID_Makers_SetDiag | "" | 00 00 00 09 00 00 00 06 And 00 00 00 09 00 00 00 03 | Null | Null | "PortLocked" | "PortLocked" |
| 00 00 00 08 00 00 8C 07 | SID_Makers_GetDiag | "" | 00 00 00 09 00 00 00 06 And 00 00 00 09 00 00 00 03 | Null | Null | "PortLocked" | "PortLocked" |
| 00 00 00 08 00 00 8C 08 | SID_SetPort | "" | 00 00 00 09 00 00 00 06 | Null | Null | "PortLocked" | "PortLocked" |
| 00 00 00 08 00 00 8C 09 | SID_GetPort | "" | 00 00 00 09 00 00 00 06 | Null | Null | "LockOnReset" | "PortLocked" |
| 00 00 00 09 00 01 FF 01 | ACE_Makers_Set_Enabled | "" | 00 00 00 09 00 00 00 06 | Null | Null | "" | "" |

Table 83 Modified 'Admin SP' ACE Table

The 2 lines of the table are the additional entries required to implement the firmware download port.

| Row Number | UID | Invoking ID | Method ID | Common Name | ACL | Log | Add ACE ACL | Remove ACE ACL | GetACLACL |
|------------|-----|---|--|---|---|------|-------------|----------------|---|
| VU | VU | 00 00 00 00 00 00 00 01 (This SP) | 00 00 00 06 00 00 00 0C (Authenticate) | Anybody Authenticate Admin SP | 00 00 00 08 00 00 00 01 (Anybody) | None | Null | Null | 00 00 00 08 00 00 00 01 (Anybody) |
| VU | VU | 00 00 00 09 00 00 00 00 (Authority table) | 00 00 00 06 00 00 00 08 (Next) | Makers-Next- Authority table | 00 00 00 08 00 00 00 03 (Makers) | None | Null | Null | 00 00 00 08 00 00 00 03 (Makers) |
| VU | VU | 00 00 00 09 00 00 00 01 (Anybody Authority object) | 00 00 00 06 00 00 00 06 (Get) | Anybody-Get- Anybody Authority Object | 00 00 00 08 00 00 00 01 (Anybody) | None | Null | Null | 00 00 00 08 00 00 00 01 (Anybody) |
| VU | VU | 00 00 00 09 00 00 00 03 (Makers Authority object) | 00 00 00 06 00 00 00 06 (Get) | Anybody-Get- Anybody Authority Object | 00 00 00 08 00 00 00 03 (Makers) | None | Null | Null | 00 00 00 08 00 00 00 03 (Makers) |
| VU | VU | 00 00 00 09 00 00 00 06 (SID Authority object) | 00 00 00 06 00 00 00 06 (Get) | SID-Get-SID Authority Object | 00 00 00 08 00 00 02 01 (SID) | None | Null | Null | 00 00 00 08 00 00 02 01 (SID) |

Table 84 Modified 'Admin SP' Access Control Table (part 1 of 2)

| Row Number | UID | Invoking ID | Method ID | Common Name | ACL | Log | Add ACE ACL | Remove ACE ACL | GetACLACL |
|------------|-----|---|--|--|---|------|-------------|----------------|---|
| VU | VU | 00 00 00 0B 00 00 00 00 (C_PIN table) | 00 00 00 06 00 00 00 08 (Next) | Makers-Next-C_ PIN table | 00 00 00 08 00 00 00 02 (Makers) | None | Null | Null | 00 00 00 08 00 00 00 02 (Makers) |
| VU | VU | 00 00 00 0B 00 00 00 01 (SID C_PIN object) | 00 00 00 06 00 00 00 07 (Set) | SID_Set Self- Set-SID_C_PIN object | 00 00 00 08 00 00 8C 03 (SID_SetSelf) | None | Null | Null | 00 00 00 08 00 00 02 01 (SID) |
| VU | VU | 00 00 00 0B 00 00 84 02 (MSID C_PIN object) | 00 00 00 06 00 00 00 06 (Get) | MSID_Get-Get- MSID C_PIN object | 00 00 00 08 00 00 8C 04 (MSID_Get) | None | Null | Null | 00 00 00 08 00 00 02 01 (SID) |
| VU | VU | 00 00 00 09 00 00 00 03 (Makers Authority object) | 00 00 00 06 00 00 00 07 (Set) | SID_SetMakers- Set-Makers Authority Object | 00 00 00 08 00 00 8C 05 (SID_SetMaker s) | None | Nul | Nul | 00 00 00 08 00 00 02 01 (SID) |
| VU | VU | 00 00 00 00 00 00 00 01 (ThisSP) | 00 00 00 06 00 00 06 01 (Random) | Anybody- Random | 00 00 00 08 00 00 00 01 (Anybody) | None | Nul | Nul | 00 00 00 08 00 00 00 01 (Anybody) |
| VU | VU | 00 01 00 02 00 01 00 02 | 00 00 00 06 00 00 00 07 | SID_Set_Dload | SID_SetPort | None | Nul | Nul | 00 00 00 08 00 00 02 01 (SID) |
| VU | VU | 00 01 00 02 00 01 00 02 | 00 00 00 06 00 00 00 06 | SID_GetDload | SID_GetPort | None | Nul | Nul | 00 00 00 08 00 00 02 01 (SID) |
| VU | VU | 00 01 00 02 00 01 00 01 | 00 00 00 06 00 00 00 07 | SID_Makers_ SetDiag | SID_Makers_S etDiag | None | Nul | Nul | 00 00 00 08 00 00 02 01 (SID) |
| VU | VU | 00 01 00 02 00 01 00 02 | 00 00 00 06 00 00 00 06 | SID_Makers_ SetDiag | SID_Makers_S etDiag | None | Nul | Nul | 00 00 00 08 00 00 02 01 (SID) |
| VU | VU | 00 00 02 05 00 00 00 01 (AdminSP) | 00 00 00 06 00 00 02 03 (Activate) | SID-Activate- AdminSP | 00 00 00 08 00 00 02 01 (SID) | None | Nul | Nul | 00 00 00 08 00 00 00 01 (Anybody) |
| VU | VU | 00 00 02 05 00 00 00 01 (AdminSP) | 00 00 00 06 00 00 02 02 (Revert) | SID-Revert- AdminSP | 00 00 00 08 00 00 02 01 (SID) | None | Nul | Nul | 00 00 00 08 00 00 00 01 (Anybody) |

Table 85 Modified 'Admin SP' Access Control Table (part 2 of 2)

The last 5 and 6 line of the table are the additional entries required to implement the firmware download port. The last 2 lines of the table are the additional entries to implement the Life Cycle model for between TCG Enterprise mode and BDE mode.

9.21.8 MSID

The MSID is set for each drive at the time of manufacturing to the serial number concatenated 4 times, to create a 32 byte password. Thus, as an example, if the serial number of a drive is abcd1234, the MSID would then be set to abcd1234abcd1234abcd1234abcd1234. In TCG use cases such as “erase” or “repurpose”, this will be the MSID that is restored to the drive.

WDC serial numbers are unique and are generated according to the following general rules:

- Maximum length of the serial number is 8 characters
- Serial numbers do not contain the characters “I” or “O”.M

9.21.9 Logging

WDC logging functions will not record any sensitive data such as customer plain text data, passwords, encryption keys or wrapping keys.

9.21.10 Number of Sessions

The WDC implementation supports 1 active session at a time. In the case when a session is active and a new session is requested, the drive answers the host with SP_BUSY. This covers the following 2 scenarios.

- If an SP is in session and an attempt is made to start a second session with the same SP.
- If an SP is in session and an attempt is made to start a second session with a different SP.

9.21.11 Number of Bands

The Enterprise SSC specification calls for support of up to 1023 bands. The WDC implementation supports a maximum of 15 bands (not including Band 0).

9.21.12 Number of COMIDs

The WDC Enterprise SSC implementation supports 2 COMIDs, the minimum requirement in the Enterprise SSC specification. Only 1 COMID can be in use at any time.

9.21.13 PSID

All WDC hard disk drives include a PSID number (and a machine-readable barcode encoding of the same) on the product label. The PSID number is used to provide evidence of physical presence when required by the product’s security protocols (such as for the TCG-Revert operation), and is included on all WDC drives to enhance the product’s security.

9.21.14 Locked and Unlocked Behavior

9.21.14.1 ATA Commands behavior

The table below describes how basic ATA commands behave on encryption drives in the locked and unlocked states by TCG Enterprise feature.

| Command | Locked Band | Unlocked Band | Notes |
|----------------------------------|-----------------|---------------|------------------------|
| Check Power Mode | Executable | Executable | |
| Configure Stream | Executable | Executable | |
| Crypto Scramble Ext | Command aborted | *1 | Any Band is Locked |
| Device Configuration Restore | Executable | Executable | |
| Device Configuration Freeze Lock | Executable | Executable | |
| Device Configuration Identify | Executable | Executable | |
| Device Configuration Set | Executable | Executable | |
| Download Microcode | *2 | *2 | Depend on DL port lock |
| Download Microcode DMA | *2 | *2 | Depend on DL port lock |
| Execute Device Diagnostic | Executable | Executable | |
| Flush Cache | Executable | Executable | |
| Flush Cache Ext | Executable | Executable | |
| Format Track | Command aborted | *1 | Any Band is Locked |
| Identify Device | Executable | Executable | |
| Idle | Executable | Executable | |
| Idle Immediate | Executable | Executable | |
| Initialize Device Parameters | Executable | Executable | |
| NCQ NON-DATA | | | |
| Overwrite Ext | Command aborted | *1 | Any Band is Locked |
| Read Buffer | Executable | Executable | |
| Read DMA | Command aborted | Executable | |
| Read DMA Ext | Command aborted | Executable | |
| Read FPDMA Queued | Command aborted | Executable | |
| Read Log Ext | Executable | Executable | |
| Read Log DMA Ext | Executable | Executable | |
| Read Multiple | Command aborted | Executable | |
| Read Multiple Ext | Command aborted | Executable | |
| Read Native Max Address | Executable | Executable | |
| Read Native Max Ext | Executable | Executable | |
| Read Sector(s) | Command aborted | Executable | |
| Read Sector(s) Ext | Command aborted | Executable | |
| Read Stream DMA Ext | Command aborted | Executable | |
| Read Stream Ext | Command aborted | Executable | |
| Read Verify Sector(s) | Command aborted | Executable | |
| Read Verify Sector(s) Ext | Command aborted | Executable | |
| Recalibrate | Executable | Executable | |
| Request Sense Data Ext | Executable | Executable | |

*1: Although the band is unlocked, command is aborted when any band is locked.

*2: This is dependency in state of FW DLOAD Port Locked. Command is aborted when port is locked.

Table 86 Command table for TCG Enterprise Device Lock Operation -1

| Command | Locked Mode | Unlocked Mode | Notes |
|---|-----------------|-----------------|---------------------------|
| Sanitize Freeze Lock Ext | Command aborted | *1 | Any Band is Locked |
| Sanitize Status Ext | Command aborted | *1 | Any Band is Locked |
| SCT Read/Write Long | Executable | Executable | |
| SCT Write Same | Command aborted | Executable | |
| SCT Error Recovery Control | Executable | Executable | |
| SCT Feature Control | Executable | Executable | |
| SCT Data Table | Executable | Executable | |
| SCT Read Status | Executable | Executable | |
| Security Disable Password | Command aborted | Command aborted | Not support at TCG enable |
| Security Erase Prepare | Command aborted | Command aborted | Not support at TCG enable |
| Security Erase Unit | Command aborted | Command aborted | Not support at TCG enable |
| Security Freeze Lock | Command aborted | Command aborted | Not support at TCG enable |
| Security Set Password | Command aborted | Command aborted | Not support at TCG enable |
| Security Unlock | Command aborted | Command aborted | Not support at TCG enable |
| Seek | Executable | Executable | |
| Set Features | Executable | Executable | |
| Set Max Address | Executable | Executable | |
| Set Max Address Ext | Executable | Executable | |
| Set Multiple Mode | Executable | Executable | |
| Set Sector Configuration Ext | Command aborted | *1 | Any Band is Locked |
| Sleep | Executable | Executable | |
| SMART Disable Operations | Executable | Executable | |
| SMART Enable/Disable Attribute Autosave | Executable | Executable | |
| SMART Enable Operations | Executable | Executable | |
| SMART Execute Off-line Immediate | Command aborted | *1 | Any Band is Locked |
| SMART Read Attribute Values | Executable | Executable | |
| SMART Read Attribute Thresholds | Executable | Executable | |
| SMART Return Status | Executable | Executable | |
| SMART Save Attribute Values | Executable | Executable | |
| SMART Read Log Sector | Executable | Executable | |
| SMART Write Log Sector | Command aborted | Executable | |
| SMART Enable/Disable Automatic Off-Line | Executable | Executable | |
| Standby | Executable | Executable | |
| Standby Immediate | Executable | Executable | |

*1: Although the band is unlocked, command is aborted when any band is locked.

Table 87 Command Table for TCG Enterprise Device Lock Operation -2

Co

| Command | Locked Mode | Unlocked Mode | Notes |
|-------------------------|-----------------|---------------|---------------------|
| Trusted Receive | Executable | Executable | |
| Trusted Receive DMA | Executable | Executable | |
| Trusted Send | Executable | Executable | |
| Trusted Send DMA | Executable | Executable | |
| Write Buffer | Executable | Executable | |
| Write DMA | Command aborted | Executable | |
| Write DMA Ext | Command aborted | Executable | |
| Write DMA FUA Ext | Command aborted | Executable | |
| Write FPDMA Queued | Command aborted | Executable | |
| Write Log Ext | Command aborted | Executable | Only SCT Write same |
| | Executable | Executable | The others |
| Write Log DMA Ext | Command aborted | Executable | Only SCT Write same |
| | Executable | Executable | The others |
| Write Multiple | Command aborted | Executable | |
| Write Multiple Ext | Command aborted | Executable | |
| Write Multiple FUA Ext | Command aborted | Executable | |
| Write Sector(s) | Command aborted | Executable | |
| Write Sector(s) Ext | Command aborted | Executable | |
| Write Stream DMA Ext | Command aborted | Executable | |
| Write Stream Ext | Command aborted | Executable | |
| Write Uncorrectable Ext | Command aborted | Executable | |

Table 88 Command table for TCG Enterprise Device Lock Operation -3

9.21.14.2 TCG Enterprise SSC Commands

The table below describes how the required TCG Enterprise SSC commands behave on encryption drives in the locked and unlocked states. The TCG Enterprise requires the implementation of the Base, Admin, Locking, and Crypto Templates.

| Command | Description | unlocked | Locked |
|--------------------|---|----------|--------|
| Session Management | There are two types of sessions: 1) Read-Only session. 2) Read-Write session. The SSC requires us to support Read-Write sessions. Read-Only session is not allowed. A session is always initiated by the host. See the "Write" parameter in the Start Session method description @ TCG Core 5.2.3.1, and see SSC requirement in SSC 6.2.1.2. | | |
| Properties | Returns session properties to host. | N/A | N/A |
| Start Session | Start a session | N/A | N/A |
| Syc Session | Response to say session successfully started. | N/A | N/A |
| Close Session | End (Close) a session | N/A | N/A |

Table 89 TCG Enterprise SSC Commands Behavior -1

| Command | Description | unlocked | Locked |
|------------------|--|-------------------------|-------------------------|
| Discovery | Allows the host to discover a TCG drive, its properties, and table values. | | |
| Level 0 | Discovery request sent by host as IF-RCV command. Security Protocol = 0x01, COMID=0x0001 | N/A | N/A |
| Level 1 | Request basic TPER capabilities via properties using host messaging. | Uses properties method. | Uses properties method. |
| Level 2 | TCG methods retrieve table cell values. | See methods below. | See methods below. |

Table 90 TCG Enterprise SSC Commands Behavior -2

| Command | Description | unlocked | Locked |
|-------------------------------|---|--|--|
| Cryptographic Template | | | |
| Random | This is the only required method in the crypto template for SSC. It is a random number generator in software. | N/A - Not related to bands/data on drive. Authentication required. | N/A - Not related to bands/data on drive. Authentication required. |

Table 91 TCG Enterprise SSC Commands Behavior -3

| Command | Description | unlocked | Locked |
|----------------------|--|---|---|
| Base Template | Mandatory | | |
| Set | Sets a value in a table | N/A - table operations. Not related to bands/data on drive. | N/A - table operations. Not related to bands/data on drive. |
| Get | Gets (reads) a value in a table | N/A - table operations. Not related to bands/data on drive. | N/A - table operations. Not related to bands/data on drive. |
| ParamCheck LRC | TPer implements param check LRC (longitudinal Redundancy Check) on get/set method calls on PIN value | N/A | N/A |
| Next | Iterates over all the rows of a table. Method requires user to specify "where" (row in table) and a "count". If where not specified, 1st row in table is used. For count not specified, default is number of last row in table. Returns 0 or more row number/uidref pairs currently in use in table, per parameters specified. | N/A - table operations. Not related to bands/data on drive. | N/A - table operations. Not related to bands/data on drive. |
| Authenticate | Authenticate an authority within a session (session must have successfully begun). | Must be authorized. | Must be authorized. |
| GetACL | Returns contents of access controls association's ACL stored in Method Table. The result is a list of UIDREFS to ACE objects. | N/A - table operations. Not to do with bands/data on drive. | N/A - table operations. Not related to bands/data on drive. |

Table 92 TCG Enterprise SSC Commands Behavior -4

| Command | Description | unlocked | Locked |
|-------------------------|---|--------------------------|------------------|
| Locking Template | Mandatory | | |
| Erase | Cryptographically erases user data in a specified LBA range and resets the access control (locking) of that LBA range | Can erase if authorized. | Generates error. |

Table 93 TCG Enterprise SSC Commands Behavior -5

| Command | Description | TCG Inactivated | TCG Activated |
|-----------------------|--|--|---|
| Admin Template | Customer specific | | |
| Activate | TCG Enterprise feature is activated form inactive mode (BDE mode) to activation mode. Note: Command is aborted at locked of ATA Security Feature, and command is received at unlocked ATA Security Feature but Activation is prohibited | Must be authorized when ATA Security Feature is disabled | Command received but Activation is prohibited |
| Revert | TCG Enterprise feature is reverted form activation mode to inactive mode(BDE mode) Note: Command is aborted at locked of ATA Security Feature, and command is received at unlocked ATA Security Feature but Activation is prohibited | Command received but Revert is prohibited | Can Revert if must be authorized |

Table 94 TCG Enterprise SSC Commands Behavior -6

9.21.15 Error Codes

All error codes are compliant with the TCG Core specification and SIIF, except in the following case:

- The maximum sessions allowed at any single time is 1. When a session is active and a new session is requested, the drive answers the host with SP_BUSY, instead of NO_SESSIONS_AVAILABLE.

9.21.16 Life Cycle Model

A Life Cycle model for TCG is able to combine TCG and BDE (with ATA security feature) features in a single code and to switch back and forth between TCG and BDE modes. The Life Cycle model based on TCG Core specification [1] and TCG Opal SSC specification [4] is applied to TCG Enterprise.

9.21.16.1 Switching Between TCG Enterprise and BDE Modes

The switching feature is managed by the Life Cycle model.

TCG / BDE combined code switches back and forth between TCG Enterprise mode and BDE mode by invoking TCG Method (Activate / Revert). Switching from BDE mode to TCG Enterprise mode is executed by “Activate method with SID”. And switching from TCG Enterprise mode to BDE mode is executed by “Revert method with SID”. AdminSP is working even if the drive is under BDE mode, and LockingSP is enabled when the drive is under TCG mode.

| | |
|-----------------|----------------------|
| Activate method | BDE → TCG Enterprise |
| Revert method | BDE ← TCG Enterprise |

Host can execute Activate and Revert methods like other TCG methods.

Both Activate and Revert methods initialize TCG setting.

When the TCG / BDE combined drive is switched to another mode, it regenerates Encryption Key. That is, encrypted user data becomes to garbage data.

9.21.16.2 ATA Security Feature Management

Command execution for ATA security feature is corresponded to TCG Life Cycle model (active or inactive), and for Trusted Receive command, Trusted Send command and those subcommands are depended on ATA security status. When TCG Enterprise is activated, the ATA security feature set is the same as not supported. And when the ATA security feature set is enabled, TCG Enterprise cannot be activated.

The values to set to Identify Device information are modified corresponding to ATA security status and TCG Life Cycle model.

9.21.17 Customer Specific Requirements

This specification does not cover customer-specific requirements. Customer-specific requirements are submitted by the customer to WDC in the form of a customer-specification document.

9.21.18 Switching Between TCG Enterprise and ISE Model

The SED model includes TCG/ISE switchable model.

A Life Cycle model for TCG is able to combine TCG and ISE (with ATA security feature) features in a single code and to switch back and forth between TCG and ISE modes. The Life Cycle model based on TCG Core specification [1] and TCG Opal SSC specification [4] is applied to TCG Enterprise.

The switching feature is managed by the Life Cycle model.

TCG / ISE combined code switches back and forth between TCG Enterprise mode and ISE mode by TCG operation. Ship ISE mode as default. Switching from ISE mode to TCG Enterprise mode is executed by “Authenticate BandMasterN or EraseMaster”. And switching from TCG Enterprise mode to ISE mode is executed by “Revert method with PSID”. AdminSP is working even if the drive is under ISE mode, and LockingSP is enabled when the drive is under TCG mode.

Revert methods initialize TCG setting and regenerates Encryption Key. That is, encrypted user data becomes to garbage data.

Port Lock cannot be used in ISE mode. Set Method to Port Table will fail when ISE mode.

Level 0 Discovery reports 1 as LockingEnabled except SEC2/4/5/6.

StartSession with LockingSP is not allowed when SEC2/4/5/6.

After successful Authentication with EraseMaster or BandMasterN, Identify Device Data Word 128 changes to 0000h. This indicates that the ATA Security command is not available. After that, after successful PSID Revert, Identify Device Data Word 128 changes to value indicating an ATA Security state (SEC1).

Level 0 Discovery always returns 1 as Locking Enabled. If it is SATA, Level 0 Discovery returns 0 as Locking Enabled when SEC2/4/5/6.

When in ISE mode, ATA Security command is not allowed during TCG Session with AdminSP or LockingSP.

9.21.19 Block SID Authentication

If a Block SID Authentication command has been successfully executed, SID Authentication will be blocked. This feature based on TCG Storage Feature Set: Block SID Authentication Specification Version 1.00 Published Revision 1.00.

If Block SID Authentication is supported, Level 0 Discovery returns feature descriptor as Feature Code = 0402. The Block SID Authentication command is delivered by the transport IF-SEND command. There is no IF-RECV response to the Block SID Authentication command.

The Block SID Authentication command is defined as follows:

Command: IF_SENF

Protocol ID: 0x02

Transfer Length: Non-zero

ComID: 0x0005

Byte 0: Clear Events (0 or 1)

Bytes 1 to Transfer Length -1: Reserved (00)

Block SID Authentication state will be cleared by Power Cycle or Revert Method. If a Block SID Authentication command issued with Clear Events = 1, Block SID Authentication state is also cleared by Hardware Reset.

10 Command Protocol

The commands are grouped into different classes according to the protocols followed for command execution. The command classes with their associated protocols are defined below.

Please refer to Serial ATA Revision 3.2 about each protocol.

For all commands, the host must first check if BSY=1, and should proceed no further unless and until BSY=0. For all commands, the host must also wait for RDY=1 before proceeding.

A device must maintain either BSY=1 or DRQ=1 at all times until the command is completed. The INTRQ signal is used by the device to signal most, but not all, times when the BSY bit is changed from 1 to 0 during command execution.

A command shall only be interrupted with a COMRESET or software reset. The result of writing to the Command register while BSY=1 or DRQ=1 is unpredictable and may result in data corruption. A command should only be interrupted by a reset at times when the host thinks there may be a problem, such as a device that is no longer responding.

Interrupts are cleared when the host reads the Status Register, issues a reset, or writes to the Command Register.

10.1 PIO Data-In Commands

These commands are:

- Device Configuration Identify
- Identify Device
- Read Buffer
- Read Log Ext
- Read Multiple
- Read Multiple Ext
- Read Sector(s)
- Read Sector(s) Ext
- Read Stream Ext
- SMART Read Attribute Values
- SMART Read Attribute Thresholds
- SMART Read Log Sector
- Trusted Receive

Execution includes the transfer of one or more 512 byte sectors of data from the device to the host.

10.2 PIO Data-Out Commands

These commands are:

- Device Configuration Set
- Download Microcode
- Format Track
- Security Disable Password
- Security Erase Unit
- Security Set Password
- Security Unlock
- Set Max Set Password command
- Set Max Unlock command
- SMART Write Log Sector
- Trusted Send
- Write Buffer
- Write Log Ext

- Write Multiple
- Write Multiple Ext
- Write Multiple FUA Ext
- Write Sector(s)
- Write Sector(s) Ext
- Write Stream Ext

Execution includes the transfer of one or more 512 byte sectors of data from the host to the device.

10.3 Non-Data Commands

These commands are:

- Check Power Mode
- Configure Stream
- Crypto Scramble Ext
- Device Configuration Freeze Lock
- Device Configuration Restore
- Execute Device Diagnostic
- Flush Cache
- Flush Cache Ext
- Idle
- Idle Immediate
- Initialize Device Parameters
- NCQ NON-DATA
- NOP
- Overwrite Ext
- Read Native Max Address
- Read Native Max Address Ext
- Read Verify Sector(s)
- Read Verify Sector(s) Ext
- Recalibrate
- Sanitize Freeze Lock Ext
- Sanitize Status Ext
- Security Erase Prepare
- Security Freeze Lock
- Seek
- Set Features
- Set Max Address
- Set Max Address Ext
- Set Max Lock command
- Set Max Freeze Lock command
- Set Multiple Mode
- Sleep
- SMART Disable Operations
- SMART Enable/Disable Attribute Autosave
- SMART Enable Operations
- SMART Execute Off-line Data Collection
- SMART Return Status
- SMART Save Attribute Values
- SMART Enable/Disable Automatic Off-Line
- Standby
- Standby Immediate
- Write Uncorrectable Ext

Execution of these commands involves no data transfer.

10.4 DMA Data-In Commands and DMA Data-Out Commands

These commands are:

- Download Microcode DMA
- Read DMA
- Read DMA Ext
- Read Log DMA Ext
- Read Stream DMA Ext
- Trusted Receive DMA
- Trusted Send DMA
- Write DMA
- Write DMA Ext
- Write DMA FUA Ext
- Write Log DMA Ext
- Write Stream DMA Ext

Execution of this class of command includes the transfer of one or more blocks of data between the device and the host using DMA transfer.

10.5 First-Party DMA Commands

These commands are:

- Read FPDMA Queued
- Write FPDMA Queued

Execution of this class of commands includes command queuing and the transfer of one or more blocks of data between the device and the host. The protocol is described in the section 13.6 “Native Command Queuing” of “Serial ATA Revision 3.2”.

Host knowledge of I/O priority may be transmitted to the device as part of the command. There are two priority classes for NCQ command as high priority, the host is requesting a better quality of service for that command than the commands issued with normal priority.

The classes are forms of soft priority. The device may choose to complete a normal priority command before an outstanding high priority command, although preference is given to the high priority commands. The priority class is indicated in bit 7 (Priority Information) in the Sector Count register for NCQ commands (READ FPDMA QUEUED and WRITE FPDMA QUEUED). This bit can indicate either the normal priority or high priority class. If a command is marked by the host as high priority, the device attempts to provide better quality of service for the command. The device may not process all high priority requests before satisfying normal priority requests.

11 Command Descriptions

| Protocol | Command | Code | Binary Code Bit | | | | | | | |
|----------|----------------------------------|-------|-----------------|---|---|---|---|---|---|---|
| | | (Hex) | 7 | 6 | 5 | 4 | 3 | 2 | 1 | 0 |
| 3 | Check Power Mode | E5 | 1 | 1 | 1 | 0 | 0 | 1 | 0 | 1 |
| 3 | Check Power Mode* | 98 | 1 | 0 | 0 | 1 | 1 | 0 | 0 | 0 |
| 3 | Configure Stream | 51 | 0 | 1 | 0 | 1 | 0 | 0 | 0 | 1 |
| 3 | Crypto Scramble Ext | B4 | 1 | 0 | 1 | 1 | 0 | 1 | 0 | 0 |
| 3 | Device Configuration Restore | B1 | 1 | 0 | 1 | 1 | 0 | 0 | 0 | 1 |
| 3 | Device Configuration Freeze Lock | B1 | 1 | 0 | 1 | 1 | 0 | 0 | 0 | 1 |
| 1 | Device Configuration Identify | B1 | 1 | 0 | 1 | 1 | 0 | 0 | 0 | 1 |
| 2 | Device Configuration Set | B1 | 1 | 0 | 1 | 1 | 0 | 0 | 0 | 1 |
| 2 | Download Microcode | 92 | 1 | 0 | 0 | 1 | 0 | 0 | 1 | 0 |
| 3 | Execute Device Diagnostic | 90 | 1 | 0 | 0 | 1 | 0 | 0 | 0 | 0 |
| 3 | Flush Cache | E7 | 1 | 1 | 1 | 0 | 0 | 1 | 1 | 1 |
| 3 | Flush Cache Ext | EA | 1 | 1 | 1 | 0 | 1 | 0 | 1 | 0 |
| 2 | Format Track | 50 | 0 | 1 | 0 | 1 | 0 | 0 | 0 | 0 |
| 1 | Identify Device | EC | 1 | 1 | 1 | 0 | 1 | 1 | 0 | 0 |
| 3 | Idle | E3 | 1 | 1 | 1 | 0 | 0 | 0 | 1 | 1 |
| 3 | Idle* | 97 | 1 | 0 | 0 | 1 | 0 | 1 | 1 | 1 |
| 3 | Idle Immediate | E1 | 1 | 1 | 1 | 0 | 0 | 0 | 0 | 1 |
| 3 | Idle Immediate* | 95 | 1 | 0 | 0 | 1 | 0 | 1 | 0 | 1 |
| 3 | Initialize Device Parameters | 91 | 1 | 0 | 0 | 1 | 0 | 0 | 0 | 1 |
| 3 | NCQ NON-DATA | 63 | 0 | 1 | 1 | 0 | 0 | 0 | 1 | 1 |
| 3 | Overwrite Ext | B4 | 1 | 0 | 1 | 1 | 0 | 1 | 0 | 0 |
| 1 | Read Buffer | E4 | 1 | 1 | 1 | 0 | 0 | 1 | 0 | 0 |
| 4 | Read DMA | C8 | 1 | 1 | 0 | 0 | 1 | 0 | 0 | 0 |
| 4 | Read DMA | C9 | 1 | 1 | 0 | 0 | 1 | 0 | 0 | 1 |
| 4 | Read DMA Ext | 25 | 0 | 0 | 1 | 0 | 0 | 1 | 0 | 1 |
| 5 | Read FPDMA Queued | 60 | 0 | 1 | 1 | 0 | 0 | 0 | 0 | 0 |
| 1 | Read Log Ext | 2F | 0 | 0 | 1 | 0 | 1 | 1 | 1 | 1 |
| 4 | Read Log DMA Ext | 47 | 0 | 1 | 0 | 0 | 0 | 1 | 1 | 1 |
| 1 | Read Multiple | C4 | 1 | 1 | 0 | 0 | 0 | 1 | 0 | 0 |
| 1 | Read Multiple Ext | 29 | 0 | 0 | 1 | 0 | 1 | 0 | 0 | 1 |
| 3 | Read Native Max Address | F8 | 1 | 1 | 1 | 1 | 1 | 0 | 0 | 0 |
| 3 | Read Native Max Address Ext | 27 | 0 | 0 | 1 | 0 | 0 | 1 | 1 | 1 |
| 1 | Read Sector(s) | 20 | 0 | 0 | 1 | 0 | 0 | 0 | 0 | 0 |
| 1 | Read Sector(s) | 21 | 0 | 0 | 1 | 0 | 0 | 0 | 0 | 1 |
| 1 | Read Sector(s) Ext | 24 | 0 | 0 | 1 | 0 | 0 | 1 | 0 | 0 |
| 4 | Read Stream DMA Ext | 2A | 0 | 0 | 1 | 0 | 1 | 0 | 1 | 0 |
| 4 | Read Stream Ext | 2B | 0 | 0 | 1 | 0 | 1 | 0 | 1 | 0 |
| 3 | Read Verify Sector(s) | 40 | 0 | 1 | 0 | 0 | 0 | 0 | 0 | 0 |
| 3 | Read Verify Sector(s) | 41 | 0 | 1 | 0 | 0 | 0 | 0 | 0 | 1 |
| 3 | Read Verify Sector(s) Ext | 42 | 0 | 1 | 0 | 0 | 0 | 0 | 1 | 0 |
| 3 | Recalibrate | 1x | 0 | 0 | 0 | 1 | - | - | - | - |
| 3 | Sanitize Freeze Lock Ext | B4 | 1 | 0 | 1 | 1 | 0 | 1 | 0 | 0 |
| 3 | Sanitize Status Ext | B4 | 1 | 0 | 1 | 1 | 0 | 1 | 0 | 0 |

Table 95 Command Set

| Protocol | Command | Code | Binary Code Bit | | | | | | | |
|----------|--|-------|-----------------|---|---|---|---|---|---|---|
| | | (Hex) | 7 | 6 | 5 | 4 | 3 | 2 | 1 | 0 |
| 2 | Security Disable Password | F6 | 1 | 1 | 1 | 1 | 1 | 0 | 1 | 0 |
| 3 | Security Erase Prepare | F3 | 1 | 1 | 1 | 1 | 0 | 0 | 1 | 1 |
| 2 | Security Erase Unit | F4 | 1 | 1 | 1 | 1 | 0 | 1 | 0 | 0 |
| 3 | Security Freeze Lock | F5 | 1 | 1 | 1 | 1 | 0 | 1 | 0 | 1 |
| 2 | Security Set Password | F1 | 1 | 1 | 1 | 1 | 0 | 0 | 0 | 1 |
| 2 | Security Unlock | F2 | 1 | 1 | 1 | 1 | 0 | 0 | 1 | 0 |
| 3 | Seek | 7x | 0 | 1 | 1 | 1 | - | - | - | - |
| 3 | Set Features | EF | 1 | 1 | 1 | 0 | 1 | 1 | 1 | 1 |
| 3 | Set Max Address | F9 | 1 | 1 | 1 | 1 | 1 | 0 | 0 | 1 |
| 3 | Set Max Address Ext | 37 | 0 | 0 | 1 | 1 | 0 | 1 | 1 | 1 |
| 3 | Set Multiple Mode | C6 | 1 | 1 | 0 | 0 | 0 | 1 | 1 | 0 |
| 3 | Set Sector Configuration Ext | B2 | 1 | 0 | 1 | 1 | 0 | 0 | 1 | 0 |
| 3 | Sleep | E6 | 1 | 1 | 1 | 0 | 0 | 1 | 1 | 0 |
| 3 | Sleep* | 99 | 1 | 0 | 0 | 1 | 1 | 0 | 0 | 1 |
| 3 | SMART Disable Operations | B0 | 1 | 0 | 1 | 1 | 0 | 0 | 0 | 0 |
| 3 | SMART Enable/Disable Attribute Auto save | B0 | 1 | 0 | 1 | 1 | 0 | 0 | 0 | 0 |
| 3 | SMART Enable Operations | B0 | 1 | 0 | 1 | 1 | 0 | 0 | 0 | 0 |
| 3 | SMART Execute Off-line Data Collection | B0 | 1 | 0 | 1 | 1 | 0 | 0 | 0 | 0 |
| 1 | SMART Read Attribute Values | B0 | 1 | 0 | 1 | 1 | 0 | 0 | 0 | 0 |
| 1 | SMART Read Attribute Thresholds | B0 | 1 | 0 | 1 | 1 | 0 | 0 | 0 | 0 |
| 3 | SMART Return Status | B0 | 1 | 0 | 1 | 1 | 0 | 0 | 0 | 0 |
| 3 | SMART Save Attribute Values | B0 | 1 | 0 | 1 | 1 | 0 | 0 | 0 | 0 |
| 2 | SMART Write Log Sector | B0 | 1 | 0 | 1 | 1 | 0 | 0 | 0 | 0 |
| 3 | SMART Enable/Disable Automatic Off-line | B0 | 1 | 0 | 1 | 1 | 0 | 0 | 0 | 0 |
| 3 | Standby | E2 | 1 | 1 | 1 | 0 | 0 | 0 | 1 | 0 |
| 3 | Standby* | 96 | 1 | 0 | 0 | 1 | 0 | 1 | 1 | 0 |
| 3 | Standby Immediate | E0 | 1 | 1 | 1 | 0 | 0 | 0 | 0 | 0 |
| 3 | Standby Immediate* | 94 | 1 | 0 | 0 | 1 | 0 | 1 | 0 | 0 |
| 1 | Trusted Receive | 5C | 0 | 1 | 0 | 1 | 1 | 1 | 0 | 0 |
| 4 | Trusted Receive DMA | 5D | 0 | 1 | 0 | 1 | 1 | 1 | 0 | 1 |
| 2 | Trusted Send | 5E | 0 | 1 | 0 | 1 | 1 | 1 | 1 | 0 |
| 4 | Trusted Send DMA | 5F | 0 | 1 | 0 | 1 | 1 | 1 | 1 | 1 |
| 2 | Write Buffer | E8 | 1 | 1 | 1 | 0 | 1 | 0 | 0 | 0 |
| 4 | Write DMA | CA | 1 | 1 | 0 | 0 | 1 | 0 | 1 | 0 |
| 4 | Write DMA | CB | 1 | 1 | 0 | 0 | 1 | 0 | 1 | 1 |
| 4 | Write DMA Ext | 35 | 0 | 0 | 1 | 1 | 0 | 1 | 0 | 1 |
| 4 | Write DMA FUA Ext | 3D | 0 | 0 | 1 | 1 | 1 | 1 | 0 | 1 |
| 5 | Write FPDMA Queued | 61 | 0 | 1 | 1 | 0 | 0 | 0 | 0 | 1 |
| 2 | Write Log Ext | 3F | 0 | 0 | 1 | 1 | 1 | 1 | 1 | 1 |
| 4 | Write Log DMA Ext | 57 | 0 | 1 | 0 | 1 | 0 | 1 | 1 | 1 |
| 2 | Write Multiple | C5 | 1 | 1 | 0 | 0 | 0 | 1 | 0 | 1 |
| 2 | Write Multiple Ext | 39 | 0 | 0 | 1 | 1 | 1 | 0 | 0 | 1 |
| 2 | Write Multiple FUA Ext | CE | 1 | 1 | 0 | 0 | 1 | 1 | 1 | 0 |

Table 96 Command Set –Continued–

| Protocol | Command | Code | Binary Code Bit | | | | | | | |
|----------|-------------------------|-------|-----------------|---|---|---|---|---|---|---|
| | | (Hex) | 7 | 6 | 5 | 4 | 3 | 2 | 1 | 0 |
| 2 | Write Sector(s) | 30 | 0 | 0 | 1 | 1 | 0 | 0 | 0 | 0 |
| 2 | Write Sector(s) | 31 | 0 | 0 | 1 | 1 | 0 | 0 | 0 | 1 |
| 2 | Write Sector(s) Ext | 34 | 0 | 0 | 1 | 1 | 0 | 1 | 0 | 0 |
| 4 | Write Stream DMA Ext | 3A | 0 | 0 | 1 | 1 | 1 | 0 | 1 | 0 |
| 4 | Write Stream Ext | 3B | 0 | 0 | 1 | 1 | 1 | 0 | 1 | 1 |
| 3 | Write Uncorrectable Ext | 45 | 0 | 1 | 0 | 0 | 0 | 1 | 0 | 1 |

Protocol : 1 : PIO data IN command
 2 : PIO data OUT command
 3 : Non data command
 4 : DMA command
 5 : DMA Queued command
 + : Vendor specific command

Table 97 Command Set –Continued–

Commands marked * are alternate command codes for previous defined commands.

| Command (Subcommand) | Command code (Hex) | Feature Register (Hex) |
|--|--------------------|------------------------|
| (SMART Function) | | |
| SMART Read Attribute Values | B0 | D0 |
| SMART Read Attribute Thresholds | B0 | D1 |
| SMART Enable/Disable Attribute Autosave | B0 | D2 |
| SMART Save Attribute Values | B0 | D3 |
| SMART Execute Off-line Data Collection | B0 | D4 |
| SMART Read Log | B0 | D5 |
| SMART Write Log | B0 | D6 |
| SMART Enable Operations | B0 | D8 |
| SMART Disable Operations | B0 | D9 |
| SMART Return Status | B0 | DA |
| SMART Enable/Disable Automatic Off-line | B0 | DB |
| (Set Features) | | |
| Enable Write Cache | EF | 02 |
| Set Transfer Mode | EF | 03 |
| Enable Advanced Power Management | EF | 05 |
| Enable Power-up in Standby Feature Set | EF | 06 |
| Power-up in Standby Feature Set Device Spin-up | EF | 07 |
| Disable read look-ahead feature | EF | 55 |
| Disable reverting to power on defaults | EF | 66 |
| Disable write cache | EF | 82 |
| Disable Advanced Power Management | EF | 85 |
| Disable Power-up in Standby Feature Set | EF | 86 |
| Enable read look-ahead feature | EF | AA |
| Enable reverting to power on defaults | EF | CC |
| (Sanitize Device Feature Set) | | |
| Sanitize Status Ext | B4 | 0000 |
| Crypto Scramble Ext | B4 | 0011 |
| Overwrite Ext | B4 | 0014 |
| Sanitize Freeze Lock Ext | B4 | 0020 |
| (NCQ NON-DATA) | | |
| Abort NCQ queue – Abort All | 63 | 00 |
| Abort NCQ queue – Abort Streaming | 63 | 10 |
| Abort NCQ queue – Abort Non-Streaming | 63 | 20 |
| Abort NCQ queue – Abort Selected | 63 | 30 |
| Deadline Handling – WDNC | 63 | Set:11 Clear:01 |
| Deadline Handling – RDNC | 63 | Set:21 Clear:01 |

Table 98 Command Set (Subcommand)

Table 95 Command Set on the page 134 and Table 96 Command Set –Continued– on the page 135 show the commands that are supported by the device. Table 98 Command Set (Subcommand) on the page 137 shows the sub-commands they are supported by each command or feature.

The following symbols are used in the command descriptions:

Output Registers

- 0** Indicates that the bit must be set to 0.
- 1** Indicates that the bit must be set to 1.
- D** The device number bit. Indicates that the device number bit of the Device/Head Register should be specified. This bit is reserved since all Serial ATA devices behave like Device 0.
- H** Head number. Indicates that the head number part of the Device/Head Register is an output parameter and should be specified.
- L** LBA mode. Indicates the addressing mode. Zero specifies CHS mode and one does LBA addressing mode.
- R** Retry. Original meaning is already obsolete, there is no difference between 0 and 1. (Using 0 is recommended for future compatibility.)
- B** Option Bit. Indicates that the Option Bit of the Sector Count Register should be specified. (This bit is used by Set Max ADDRESS command)
- V** Valid. Indicates that the bit is part of an output parameter and should be specified.
- X** Indicates that the hex character is not used.
- Indicates that the bit is not used.

Input Registers

- 0** Indicates that the bit is always set to 0.
- 1** Indicates that the bit is always set to 1.
- H** Head number. Indicates that the head number part of the Device/Head Register is an input parameter and will be set by the device.
- V** Valid. Indicates that the bit is part of an input parameter and will be set to 0 or 1 by the device.
- Indicates that the bit is not part of an input parameter.

The command descriptions show the contents of the Status and Error Registers after the device has completed processing the command and has interrupted the host.

Please refer to ATA interface specifications about other commands' descriptions which are not described in this SATA interface specification. However, be careful that Serial ATA Device/Head register bit-4 (d) is different from that of Parallel ATA. In Serial ATA, Device/Head register bit-4 is reserved for all commands.

11.1 Check Power Mode (E5h/98h)

| Command Block Output Registers | | | | | | | | |
|--------------------------------|---|---|---|---|---|---|---|---|
| Register | 7 | 6 | 5 | 4 | 3 | 2 | 1 | 0 |
| Data | - | - | - | - | - | - | - | - |
| Feature | - | - | - | - | - | - | - | - |
| Sector Count | - | - | - | - | - | - | - | - |
| Sector Number | - | - | - | - | - | - | - | - |
| Cylinder Low | - | - | - | - | - | - | - | - |
| Cylinder High | - | - | - | - | - | - | - | - |
| Device/Head | 1 | - | 1 | D | - | - | - | - |
| Command | 1 | 1 | 1 | 0 | 0 | 1 | 0 | 1 |

| Command Block Input Registers | | | | | | | | |
|-------------------------------|-----------------|---|---|---|---|---|---|---|
| Register | 7 | 6 | 5 | 4 | 3 | 2 | 1 | 0 |
| Data | - | - | - | - | - | - | - | - |
| Error | ...See Below... | | | | | | | |
| Sector Count | V | V | V | V | V | V | V | V |
| Sector Number | - | - | - | - | - | - | - | - |
| Cylinder Low | - | - | - | - | - | - | - | - |
| Cylinder High | - | - | - | - | - | - | - | - |
| Device/Head | - | - | - | - | - | - | - | - |
| Status | ...See Below... | | | | | | | |

| Error Register | | | | | | | |
|----------------|-----|---|-----|---|-----|-----|-----|
| 7 | 6 | 5 | 4 | 3 | 2 | 1 | 0 |
| CRC | UNC | 0 | IDN | 0 | ABT | T0N | AMN |
| 0 | 0 | 0 | 0 | 0 | V | 0 | 0 |

| Status Register | | | | | | | |
|-----------------|-----|----|-----|-----|-----|-----|-----|
| 7 | 6 | 5 | 4 | 3 | 2 | 1 | 0 |
| BSY | RDY | DF | DSC | DRQ | COR | IDX | ERR |
| 0 | V | 0 | - | - | 0 | - | V |

Table 99 Check Power Mode Command (E5h/98h)

The Check Power Mode command will report whether the device is spun up and the media is available for immediate access.

Input Parameters From The Device

Sector Count The power mode code.

If the Extended Power Conditions feature set is disabled and the device is in Idle mode, Check Power Mode returns FFh by Sector Count Register, instead of returning 80h. Check Power Mode returns 0 in the Sector Count Register if the device is in Standby mode.

If the Extended Power Conditions feature set is enabled, the command returns power condition. idle_a condition is 81h, idle_b condition is 82h, idle_c condition is 83h, standby_y condition is 01h, standby_z condition is 00h.

11.2 Configure Stream (51h)

| Command Block Output Registers | | | | | | | | |
|--------------------------------|----------|---|---|---|---|---|---|---|
| Register | 7 | 6 | 5 | 4 | 3 | 2 | 1 | 0 |
| Data Low | - | - | - | - | - | - | - | - |
| Data High | - | - | - | - | - | - | - | - |
| Feature | Current | V | V | - | - | - | V | V |
| | Previous | V | V | V | V | V | V | V |
| Sector Count | Current | V | V | V | V | V | V | V |
| | Previous | V | V | V | V | V | V | V |
| Sector Number | Current | - | - | - | - | - | - | - |
| | Previous | - | - | - | - | - | - | - |
| Cylinder Low | Current | - | - | - | - | - | - | - |
| | Previous | - | - | - | - | - | - | - |
| Cylinder High | Current | - | - | - | - | - | - | - |
| | Previous | - | - | - | - | - | - | - |
| Device/Head | 1 | 1 | 1 | D | - | - | - | - |
| Command | 0 | 1 | 0 | 1 | 0 | 0 | 0 | 1 |

| Command Block Input Registers | | | | | | | | |
|-------------------------------|------------------|---|---|---|---|---|---|---|
| Register | 7 | 6 | 5 | 4 | 3 | 2 | 1 | 0 |
| Data Low | - | - | - | - | - | - | - | - |
| Data High | - | - | - | - | - | - | - | - |
| Error | ... See Below... | | | | | | | |
| Sector Count | HOB=0 | - | - | - | - | - | - | - |
| | HOB=1 | - | - | - | - | - | - | - |
| Sector Number | HOB=0 | - | - | - | - | - | - | - |
| | HOB=1 | - | - | - | - | - | - | - |
| Cylinder Low | HOB=0 | - | - | - | - | - | - | - |
| | HOB=1 | - | - | - | - | - | - | - |
| Cylinder High | HOB=0 | - | - | - | - | - | - | - |
| | HOB=1 | - | - | - | - | - | - | - |
| Device/Head | - | - | - | - | - | - | - | - |
| Status | ... See Below... | | | | | | | |

| Error Register | | | | | | | |
|----------------|-----|---|-----|---|-----|-----|-----|
| 7 | 6 | 5 | 4 | 3 | 2 | 1 | 0 |
| CRC | UNC | 0 | IDN | 0 | ABT | T0N | AMN |
| 0 | 0 | 0 | 0 | 0 | V | 0 | 0 |

| Status Register | | | | | | | |
|-----------------|-----|----|-----|-----|-----|-----|-----|
| 7 | 6 | 5 | 4 | 3 | 2 | 1 | 0 |
| BSY | RDY | SE | DSC | DRQ | COR | IDX | ERR |
| 0 | V | 0 | V | - | 0 | - | V |

Table 100 Configure Stream Command (51h)

The Configure Stream command specifies the operating parameters of an individual stream. A Configure Stream command may be issued for each stream that is to be added or removed from the current operating configuration. If A/R = 1 and the specified ID is already valid at the device, the new parameters shall replace the old parameters, unless Command Abort is returned (see abort conditions for Error Register). In this case the old parameters for the specified Stream ID shall remain in effect.

Abort conditions for Error register are the following.

- The device does not support the Streaming Feature Set.
- A/R is cleared to zero and the Feature field contains a Stream ID that has not been sent in a previous CONFIGURE STREAM command.

Output Parameters To The Device

Feature Current bit 7 (A/R)

If set to one, a request to add a new stream.

If cleared to zero, a request to remove a previous configured stream is specified.

Feature Current bit 6 (R/W)

R/W specifies a read stream if cleared to zero and a write stream if set to one.

Feature Current bit 0..2 (Stream ID)

The Stream ID shall be a value between 0 and 7.

Feature Previous

The default Command Completion Time Limit (CCTL).

The value is calculated as follows:

(Default CCTL) = ((content of the Features register)* (Identify Device words (99:98))) microseconds.

This time shall be used by the device when a streaming command with the same stream ID and a CCTL of zero are issued. The time is measured from the write of the command register to the final INTRQ for command completion. The device has minimum CCTL value. When the specified value is shorter than the minimum value, CCTL is set to the minimum value. Actual minimum CCTL value is described in the "Deviations from Standard" section.

Sector Count Current

Allocation Unit Size In Sectors (7:0)

Sector Count Previous

Allocation Unit Size In Sectors (15:8)

11.3 Device Configuration Overlay (B1h)

| Command Block Output Registers | | | | | | | | |
|--------------------------------|---|---|---|---|---|---|---|---|
| Register | 7 | 6 | 5 | 4 | 3 | 2 | 1 | 0 |
| Data | - | - | - | - | - | - | - | - |
| Feature | 1 | 0 | 1 | 0 | V | V | V | V |
| Sector Count | - | - | - | - | - | - | - | - |
| Sector Number | - | - | - | - | - | - | - | - |
| Cylinder Low | - | - | - | - | - | - | - | - |
| Cylinder High | - | - | - | - | - | - | - | - |
| Device/Head | - | - | - | D | - | - | - | - |
| Command | 1 | 0 | 1 | 1 | 0 | 0 | 0 | 1 |

| Command Block Input Registers | | | | | | | | |
|-------------------------------|-----------------|---|---|---|---|---|---|---|
| Register | 7 | 6 | 5 | 4 | 3 | 2 | 1 | 0 |
| Data | - | - | - | - | - | - | - | - |
| Error | ...See Below... | | | | | | | |
| Sector Count | V | V | V | V | V | V | V | V |
| Sector Number | - | - | - | - | - | - | - | - |
| Cylinder Low | V | V | V | V | V | V | V | V |
| Cylinder High | V | V | V | V | V | V | V | V |
| Device/Head | - | - | - | - | - | - | - | - |
| Status | ...See Below... | | | | | | | |

| Error Register | | | | | | | |
|----------------|-----|---|-----|---|-----|-----|-----|
| 7 | 6 | 5 | 4 | 3 | 2 | 1 | 0 |
| CRC | UNC | 0 | IDN | 0 | ABT | T0N | AMN |
| 0 | 0 | 0 | 0 | 0 | V | 0 | 0 |

| Status Register | | | | | | | |
|-----------------|-----|----|-----|-----|-----|-----|-----|
| 7 | 6 | 5 | 4 | 3 | 2 | 1 | 0 |
| BSY | RDY | DF | DSC | DRQ | COR | IDX | ERR |
| V | V | 0 | - | V | - | - | V |

Table 101 Device Configuration Overlay Command (B1h)

Individual Device Configuration Overlay feature set commands are identified by the value placed in the Features register. The table below shows these Features register values.

| Value | Command |
|-------|----------------------------------|
| C0h | DEVICE CONFIGURATION RESTORE |
| C1h | DEVICE CONFIGURATION FREEZE LOCK |
| C2h | DEVICE CONFIGURATION IDENTIFY |
| C3h | DEVICE CONFIGURATION SET |
| other | Reserved |

Table 102 Device Configuration Overlay Features Register Values

11.3.1 Device Configuration Restore (Subcommand C0h)

The Device Configuration Restore command disables any setting previously made by a Device Configuration Set command and returns the content of the Identify Device or Identify Packet Device command response to the original settings as indicated by the data returned from the execution of a Device Configuration Identify command.

11.3.2 Device Configuration Freeze Lock (Subcommand C1h)

The Device Configuration Freeze Lock command prevents accidental modification of the Device Configuration Overlay settings. After successful execution of a Device Configuration Freeze Lock command, all Device Configuration Set, Device Configuration Freeze Lock, Device Configuration Identify, and Device Configuration Restore commands are aborted by the device. The Device Configuration Freeze Lock condition shall be cleared by a power-down. The Device Configuration Freeze Lock condition shall not be cleared by hardware or software reset.

11.3.3 Device Configuration Identify (Subcommand C2h)

The Device Configuration Identify command returns a 512 byte data structure via PIO data-in transfer. The content of this data structure indicates the selectable commands, modes, and feature sets that the device is capable of supporting. If a Device Configuration Set command has been issued reducing the capabilities, the response to an Identify Device or Identify Packet Device command will reflect the reduced set of capabilities, while the Device Configuration Identify command will reflect the entire set of selectable capabilities.

The format of the Device Configuration Overlay Data structure is shown on next page.

11.3.4 Device Configuration Set (Subcommand C3h)

The Device Configuration Set command allows a device manufacturer or a personal computer system manufacturer to reduce the set of optional commands, modes, or feature sets supported by a device as indicated by a Device Configuration Identify command. The Device Configuration Set command transfers an overlay that modifies some of the bits set in words 63, 82, 83, 84, and 88 of the Identify Device command response. When the bits in these words are cleared, the device no longer supports the indicated command, mode, or feature set. If a bit is set in the overlay transmitted by the device that is not set in the overlay received from a Device Configuration Identify command, no action is taken for that bit.

The format of the overlay transmitted by the device is described in the table on next page. The restrictions on changing these bits are described in the text following that table. If any of the bit modification restrictions described is violated or any setting is changed with Device Configuration Set command, the device shall return command aborted. At that case, error reason code is returned to sector count register, invalid word location is returned to cylinder high register, and invalid bit location is returned to cylinder low register. The Definition of error information is shown on page 145.

Error Information Example 1:

After establish a protected area with Set Max address, if a user attempts to change maximum LBA address (Device Configuration Set or Device Configuration Restore), device shall abort that command and return error reason code as below.

| | | | |
|---------------|---|-----|--|
| Cylinder high | : | 03h | = word 3 is invalid |
| Cylinder low | : | 00h | this register is not assigned in this case |
| Sector Number | : | 00h | this register is not assigned in this case |
| Sector count | : | 06h | = Protected area is now established |

Error Information Example 2:

When device is enabled the Security feature set, if user attempts to disable that feature, device abort that command and return error reason code as below.

| | | | |
|---------------|---|-----|----------------------|
| Cylinder high | : | 07h | = word 7 is invalid |
| Cylinder low | : | 00h | = bit 8-15 are valid |
| Sector Number | : | 08h | = bit 3 is invalid |

Sector count : 04h = now Security feature set is enabled

| Word | Content | |
|--------|---|--|
| 0 | 0002h | Data Structure revision |
| 1 | Multiword DMA modes supported | |
| | 15-3 | Reserved |
| | 2 | 1 = Multiword DMA mode 2 and below are supported |
| | 1 | 1 = Multiword DMA mode 1 and below are supported |
| 2 | Ultra DMA modes supported | |
| | 15-7 | Reserved |
| | 6 | 1 = Ultra DMA mode 6 and below are supported |
| | 5 | 1 = Ultra DMA mode 5 and below are supported |
| | 4 | 1 = Ultra DMA mode 4 and below are supported |
| | 3 | 1 = Ultra DMA mode 3 and below are supported |
| | 2 | 1 = Ultra DMA mode 2 and below are supported |
| | 1 | 1 = Ultra DMA mode 1 and below are supported |
| 0 | 1 = Ultra DMA mode 0 is supported | |
| 3-6 | Maximum LBA address | |
| 7 | Command set/feature set supported | |
| | 15 | 0 = Reserved |
| | 14 | 0 = Reserved |
| | 13 | 0 = Reserved |
| | 12 | 1 = SMART Selective self-test is supported |
| | 11 | 1 = Forced Unit Access is supported |
| | 10 | 0 = Reserved |
| | 9 | 1 = Streaming feature set is supported |
| | 8 | 1 = 48-bit Addressing feature set supported |
| | 7 | 1 = Host Protected Area feature set supported |
| | 6 | 0 = Reserved |
| | 5 | 1 = Read/Write DMA Queued commands supported |
| | 4 | 1 = Power-up in Standby feature set supported |
| | 3 | 1 = Security feature set supported |
| | 2 | 1 = SMART error log supported |
| | 1 | 1 = SMART self-test supported |
| 0 | 1 = SMART feature set supported | |
| 8 | Serial ATA command / feature sets supported | |
| | 15-5 | Reserved |
| | 4 | 1 = Supports software settings preservation |
| | 3 | Reserved |
| | 2 | 1 = Supports interface power management |
| | 1 | 1 = Supports non-zero buffer offset in DMA Setup FIS |
| 0 | 1 = Supports native command queuing | |
| 9-20 | Reserved | |
| 21 | 15-14 | Reserved |
| | 13 | 1 = Support for WRITE UNCORRECTABLE is allowed |
| | 12-10 | Reserved |
| | 9 | 1 = Extended Power Conditions feature set supported |
| | 8-0 | Reserved |
| 22-254 | Reserved | |
| 255 | Integrity word <Note .> | |
| | 15-8 | Checksum |
| | 7-0 | Signature (A5h) |

Table 103 Device Configuration Overlay Data Structure

Note.

Bits 7:0 of this word contain the value A5h. Bits 15:8 of this word contain the data structure checksum. The data structure checksum is the two's complement of the sum of all byte in words 0 through 254 and the byte consisting of bits 7:0 of word 255. Each byte is added with unsigned arithmetic, and overflow is ignored. The sum of all bytes is zero when the checksum is correct.

| | | |
|---------------|------------------------------------|---|
| Cylinder high | invalid word location | |
| Cylinder low | invalid bit location (bits (15:8)) | |
| Sector number | invalid bit location (bits (7:0)) | |
| Sector count | error reason code & description | |
| | 01h | DCO feature is frozen |
| | 02h | Device is now Security Locked mode |
| | 03h | Device's feature is already modified with DCO |
| | 04h | User attempt to disable any feature enabled |
| | 05h | Device is now SET MAX Locked or Frozen mode |
| | 06h | Protected area is now established |
| | 07h | DCO is not supported |
| | 08h | Subcommand code is invalid |
| FFh | other reason | |

Table 104 DCO Error Information Definition

11.4 Download Microcode (92h)

| Command Block Output Registers | | | | | | | | |
|--------------------------------|----------------------|---|---|---|---|---|---|---|
| Register | 7 | 6 | 5 | 4 | 3 | 2 | 1 | 0 |
| Data | - | - | - | - | - | - | - | - |
| Feature | SUBCOMMAND(00-07) | | | | | | | |
| Sector Count | SECTOR_COUNT(00-07) | | | | | | | |
| Sector Number | SECTOR_COUNT(08-15) | | | | | | | |
| Cylinder Low | BUFFER_OFFSET(00-07) | | | | | | | |
| Cylinder High | BUFFER_OFFSET(08-15) | | | | | | | |
| Device/Head | - | - | - | D | - | - | - | - |
| Command | 1 | 0 | 0 | 1 | 0 | 0 | 1 | 0 |

| Command Block Input Registers | | | | | | | | |
|-------------------------------|-----------------|---|---|---|---|---|---|---|
| Register | 7 | 6 | 5 | 4 | 3 | 2 | 1 | 0 |
| Data | - | - | - | - | - | - | - | - |
| Error | ...See Below... | | | | | | | |
| Sector Count | - | - | - | - | - | - | - | - |
| Sector Number | - | - | - | - | - | - | - | - |
| Cylinder Low | - | - | - | - | - | - | - | - |
| Cylinder High | - | - | - | - | - | - | - | - |
| Device/Head | - | - | - | - | - | - | - | - |
| Status | ...See Below... | | | | | | | |

| Error Register | | | | | | | |
|----------------|-----|---|-----|---|-----|-----|-----|
| 7 | 6 | 5 | 4 | 3 | 2 | 1 | 0 |
| CRC | UNC | 0 | IDN | 0 | ABT | T0N | AMN |
| 0 | V | 0 | 0 | 0 | V | 0 | 0 |

| Status Register | | | | | | | |
|-----------------|-----|----|-----|-----|-----|-----|-----|
| 7 | 6 | 5 | 4 | 3 | 2 | 1 | 0 |
| BSY | RDY | DF | DSC | DRQ | COR | IDX | ERR |
| 0 | 1 | 0 | 1 | 0 | 0 | - | V |

Table 105 Download Microcode Command (92h)

Output Parameters To The Device

| | |
|----------------------|--|
| Feature | Subcommand code. 03h : Download and save microcode with offsets. 07h : Download and save microcode. 0Eh : Download with offsets and save microcode. 0Fh : Activate download microcode. Other values are reserved. |
| Sector Count | Lower byte of 16-bit sector count value to transfer from the host. |
| Sector Number | Higher byte of 16-bit sector count value to transfer from the host. |
| Cylinder | Buffer offset (only used for Feature = 03h) |

This command enables the host to alter the device's microcode. The data transferred using the DOWNLOAD MICROCODE commands is vendor specific.

The Download and save microcode with offsets subcommand(03h) transfers the updated microcode data in one or more DOWNLOAD MICROCODE commands. This subcommand downloads data containing a segment of the updated microcode data. On normal command completion, the COUNT field may contain additional indicators. If the final segment has been downloaded, the device validates the downloaded updated microcode. If the validation is successful, the downloaded updated microcode is saved to non-volatile storage and is activated. After transferring a segment where the value of the BUFFER OFFSET field is cleared to zero, if the device begins to process a command that is not a DOWNLOAD MICROCODE command, then the device:

- 1) may discard any updated microcode data that has not been saved; and
- 2) shall continue to process the new command.

The Download and save microcode subcommand(07h) transfers the updated microcode data in one DOWNLOAD MICROCODE command.

After the updated microcode data has been downloaded:

- 1) the device shall save the updated microcode data;
- 2) the device shall activate the updated microcode data; and

- 3) if command completion has not previously been returned, then the device shall return command completion.

The Download with offsets and save microcode subcommand(0Eh) transfers the updated microcode data in one or more DOWNLOAD MICROCODE commands. On normal command completion, the COUNT field may contain additional indicators.

If the final segment has been downloaded, the device validates the downloaded updated microcode. If the validation is successful, the downloaded updated microcode is saved to non-volatile storage and becomes the deferred microcode. The deferred microcode data is activated as a result of processing the next power on reset or processing an Activate downloaded microcode subcommand.

The processing of commands other than the DOWNLOAD MICROCODE command shall not affect any:

- 1) updated microcode; and
- 2) saved microcode.

The Activate downloaded microcode subcommand(0Fh) shall activate deferred microcode data that had been previously downloaded and saved by the Download with offsets and save microcode subcommand.

11.5 Download Microcode DMA (93h)

| Command Block Output Registers | | | | | | | | |
|--------------------------------|----------------------|---|---|---|---|---|---|---|
| Register | 7 | 6 | 5 | 4 | 3 | 2 | 1 | 0 |
| Data | - | - | - | - | - | - | - | - |
| Feature | SUBCOMMAND(00-07) | | | | | | | |
| Sector Count | SECTOR_COUNT(00-07) | | | | | | | |
| Sector Number | SECTOR_COUNT(08-15) | | | | | | | |
| Cylinder Low | BUFFER_OFFSET(00-07) | | | | | | | |
| Cylinder High | BUFFER_OFFSET(08-15) | | | | | | | |
| Device/Head | - | - | - | D | - | - | - | - |
| Command | 1 | 0 | 0 | 1 | 0 | 0 | 1 | 1 |

| Command Block Input Registers | | | | | | | | |
|-------------------------------|------------------|---|---|---|---|---|---|---|
| Register | 7 | 6 | 5 | 4 | 3 | 2 | 1 | 0 |
| Data | - | - | - | - | - | - | - | - |
| Error | ... See Below... | | | | | | | |
| Sector Count | - | - | - | - | - | - | - | - |
| Sector Number | - | - | - | - | - | - | - | - |
| Cylinder Low | - | - | - | - | - | - | - | - |
| Cylinder High | - | - | - | - | - | - | - | - |
| Device/Head | - | - | - | - | - | - | - | - |
| Status | ... See Below... | | | | | | | |

| Error Register | | | | | | | |
|----------------|-----|---|-----|---|-----|-----|-----|
| 7 | 6 | 5 | 4 | 3 | 2 | 1 | 0 |
| CRC | UNC | 0 | IDN | 0 | ABT | T0N | AMN |
| 0 | V | 0 | 0 | 0 | V | 0 | 0 |

| Status Register | | | | | | | |
|-----------------|-----|----|-----|-----|-----|-----|-----|
| 7 | 6 | 5 | 4 | 3 | 2 | 1 | 0 |
| BSY | RDY | DF | DSC | DRQ | COR | IDX | ERR |
| 0 | 1 | 0 | 1 | 0 | 0 | - | V |

Table 106 Download Microcode DMA Command (93h)

Output Parameters To The Device

| | |
|----------------------|--|
| Feature | Subcommand code. 03h : Download and save microcode with offsets. 07h : Download and save microcode. 0Eh : Download with offsets and save microcode. 0Fh : Activate download microcode. Other values are reserved. |
| Sector Count | Lower byte of 16-bit sector count value to transfer from the host. |
| Sector Number | Higher byte of 16-bit sector count value to transfer from the host. |
| Cylinder | Buffer offset (only used for Feature = 03h) |

This command enables the host to alter the device's microcode. The data transferred using the DOWNLOAD MICROCODE DMA commands is vendor specific.

The Download and save microcode with offsets subcommand(03h) transfers the updated microcode data in one or more DOWNLOAD MICROCODE commands. This subcommand downloads data containing a segment of the updated microcode data. On normal command completion, the COUNT field may contain additional indicators. If the final segment has been downloaded, the device validates the downloaded updated microcode. If the validation is successful, the downloaded updated microcode is saved to non-volatile storage and is activated. After transferring a segment where the value of the BUFFER OFFSET field is cleared to zero, if the device begins to process a command that is not a DOWNLOAD MICROCODE command, then the device:

- 1) may discard any updated microcode data that has not been saved; and
- 2) shall continue to process the new command.

The Download and save microcode subcommand(07h) transfers the updated microcode data in one DOWNLOAD MICROCODE command.

After the updated microcode data has been downloaded:

- 1) the device shall save the updated microcode data;

- 2) the device shall activate the updated microcode data; and
- 3) if command completion has not previously been returned, then the device shall return command completion.

The Download with offsets and save microcode subcommand(0Eh) transfers the updated microcode data in one or more DOWNLOAD MICROCODE commands. On normal command completion, the COUNT field may contain additional indicators.

If the final segment has been downloaded, the device validates the downloaded updated microcode. If the validation is successful, the downloaded updated microcode is saved to non-volatile storage and becomes the deferred microcode. The deferred microcode data is activated as a result of processing the next power on reset or processing an Activate downloaded microcode subcommand.

The processing of commands other than the DOWNLOAD MICROCODE command shall not affect any:

- 1) updated microcode; and
- 2) saved microcode.

The Activate downloaded microcode subcommand(0Fh) shall activate deferred microcode data that had been previously downloaded and saved by the Download with offsets and save microcode subcommand.

11.6 Execute Device Diagnostic (90h)

| Command Block Output Registers | | | | | | | | |
|--------------------------------|---|---|---|---|---|---|---|---|
| Register | 7 | 6 | 5 | 4 | 3 | 2 | 1 | 0 |
| Data | - | - | - | - | - | - | - | - |
| Feature | - | - | - | - | - | - | - | - |
| Sector Count | - | - | - | - | - | - | - | - |
| Sector Number | - | - | - | - | - | - | - | - |
| Cylinder Low | - | - | - | - | - | - | - | - |
| Cylinder High | - | - | - | - | - | - | - | - |
| Device/Head | 1 | - | 1 | - | - | - | - | - |
| Command | 1 | 0 | 0 | 1 | 0 | 0 | 0 | 0 |

| Command Block Input Registers | | | | | | | | |
|-------------------------------|-----------------|---|---|---|---|---|---|---|
| Register | 7 | 6 | 5 | 4 | 3 | 2 | 1 | 0 |
| Data | - | - | - | - | - | - | - | - |
| Error | ...See Below... | | | | | | | |
| Sector Count | - | - | - | - | - | - | - | - |
| Sector Number | - | - | - | - | - | - | - | - |
| Cylinder Low | - | - | - | - | - | - | - | - |
| Cylinder High | - | - | - | - | - | - | - | - |
| Device/Head | - | - | - | - | - | - | - | - |
| Status | ...See Below... | | | | | | | |

| Error Register | |
|-----------------|--|
| Diagnostic Code | |

| Status Register | | | | | | | |
|-----------------|-----|----|-----|-----|-----|-----|-----|
| 7 | 6 | 5 | 4 | 3 | 2 | 1 | 0 |
| BSY | RDY | DF | DSC | DRQ | COR | IDX | ERR |
| 0 | V | 0 | - | - | 0 | - | 0 |

Table 107 Execute Device Diagnostic Command (90h)

The Execute Device Diagnostic command performs the internal diagnostic tests implemented by the device. The results of the test are stored in the Error Register.

The normal Error Register bit definitions do not apply to this command. Instead, the register contains a diagnostic code. See Table 34 Diagnostic Codes on the page 57 for its definition.

11.7 Flush Cache (E7h)

| Command Block Output Registers | | | | | | | | |
|--------------------------------|---|---|---|---|---|---|---|---|
| Register | 7 | 6 | 5 | 4 | 3 | 2 | 1 | 0 |
| Data | - | - | - | - | - | - | - | - |
| Feature | - | - | - | - | - | - | - | - |
| Sector Count | - | - | - | - | - | - | - | - |
| Sector Number | - | - | - | - | - | - | - | - |
| Cylinder Low | - | - | - | - | - | - | - | - |
| Cylinder High | - | - | - | - | - | - | - | - |
| Device/Head | 1 | - | 1 | D | - | - | - | - |
| Command | 1 | 1 | 1 | 0 | 0 | 1 | 1 | 1 |

| Command Block Input Registers | | | | | | | | |
|-------------------------------|-----------------|---|---|---|---|---|---|---|
| Register | 7 | 6 | 5 | 4 | 3 | 2 | 1 | 0 |
| Data | - | - | - | - | - | - | - | - |
| Error | ...See Below... | | | | | | | |
| Sector Count | - | - | - | - | - | - | - | - |
| Sector Number | - | - | - | - | - | - | - | - |
| Cylinder Low | - | - | - | - | - | - | - | - |
| Cylinder High | - | - | - | - | - | - | - | - |
| Device/Head | - | - | - | - | - | - | - | - |
| Status | ...See Below... | | | | | | | |

| Error Register | | | | | | | |
|----------------|-----|---|-----|---|-----|-----|-----|
| 7 | 6 | 5 | 4 | 3 | 2 | 1 | 0 |
| CRC | UNC | 0 | IDN | 0 | ABT | T0N | AMN |
| 0 | 0 | 0 | 0 | 0 | V | 0 | 0 |

| Status Register | | | | | | | |
|-----------------|-----|----|-----|-----|-----|-----|-----|
| 7 | 6 | 5 | 4 | 3 | 2 | 1 | 0 |
| BSY | RDY | DF | DSC | DRQ | COR | IDX | ERR |
| 0 | V | 0 | V | - | 0 | - | V |

Table 108 Flush Cache Command (E7h)

This command causes the device to complete writing data from its cache.

The device returns good status after data in the write cache is written to disk media.

11.8 Flush Cache Ext (EAh)

| Command Block Output Registers | | | | | | | | |
|--------------------------------|----------|---|---|---|---|---|---|---|
| Register | 7 | 6 | 5 | 4 | 3 | 2 | 1 | 0 |
| Data Low | - | - | - | - | - | - | - | - |
| Data High | - | - | - | - | - | - | - | - |
| Feature | Current | - | - | - | - | - | - | - |
| | Previous | - | - | - | - | - | - | - |
| Sector Count | Current | - | - | - | - | - | - | - |
| | Previous | - | - | - | - | - | - | - |
| Sector Number | Current | - | - | - | - | - | - | - |
| | Previous | - | - | - | - | - | - | - |
| Cylinder Low | Current | - | - | - | - | - | - | - |
| | Previous | - | - | - | - | - | - | - |
| Cylinder High | Current | - | - | - | - | - | - | - |
| | Previous | - | - | - | - | - | - | - |
| Device/Head | - | - | - | D | - | - | - | - |
| Command | 1 | 1 | 1 | 0 | 1 | 0 | 1 | 0 |

| Command Block Input Registers | | | | | | | | |
|-------------------------------|-----------------|---|---|---|---|---|---|---|
| Register | 7 | 6 | 5 | 4 | 3 | 2 | 1 | 0 |
| Data Low | - | - | - | - | - | - | - | - |
| Data High | - | - | - | - | - | - | - | - |
| Error | ...See Below... | | | | | | | |
| Sector Count | HOB=0 | - | - | - | - | - | - | - |
| | HOB=1 | - | - | - | - | - | - | - |
| Sector Number | HOB=0 | - | - | - | - | - | - | - |
| | HOB=1 | - | - | - | - | - | - | - |
| Cylinder Low | HOB=0 | - | - | - | - | - | - | - |
| | HOB=1 | - | - | - | - | - | - | - |
| Cylinder High | HOB=0 | - | - | - | - | - | - | - |
| | HOB=1 | - | - | - | - | - | - | - |
| Device/Head | - | - | - | - | - | - | - | - |
| Status | ...See Below... | | | | | | | |

| Error Register | | | | | | | |
|----------------|-----|---|-----|---|-----|-----|-----|
| 7 | 6 | 5 | 4 | 3 | 2 | 1 | 0 |
| CRC | UNC | 0 | IDN | 0 | ABT | T0N | AMN |
| 0 | 0 | 0 | 0 | 0 | V | 0 | 0 |

| Status Register | | | | | | | |
|-----------------|-----|----|-----|-----|-----|-----|-----|
| 7 | 6 | 5 | 4 | 3 | 2 | 1 | 0 |
| BSY | RDY | DF | DSC | DRQ | COR | IDX | ERR |
| 0 | V | 0 | V | - | 0 | - | V |

Table 109 Flush Cache Ext Command (EAh)

This command causes the device to complete writing data from its cache.

The device returns good status after data in the write cache is written to disk media.

11.9 Format Track (50h)

| Command Block Output Registers | | | | | | | | |
|--------------------------------|---|---|---|---|---|---|---|---|
| Register | 7 | 6 | 5 | 4 | 3 | 2 | 1 | 0 |
| Data | - | - | - | - | - | - | - | - |
| Feature | - | - | - | - | - | - | - | - |
| Sector Count | - | - | - | - | - | - | - | - |
| Sector Number | V | V | V | V | V | V | V | V |
| Cylinder Low | V | V | V | V | V | V | V | V |
| Cylinder High | V | V | V | V | V | V | V | V |
| Device/Head | 1 | L | 1 | D | H | H | H | H |
| Command | 0 | 1 | 0 | 1 | 0 | 0 | 0 | 0 |

| Command Block Input Registers | | | | | | | | |
|-------------------------------|-----------------|---|---|---|---|---|---|---|
| Register | 7 | 6 | 5 | 4 | 3 | 2 | 1 | 0 |
| Data | - | - | - | - | - | - | - | - |
| Error | ...See Below... | | | | | | | |
| Sector Count | - | - | - | - | - | - | - | - |
| Sector Number | V | V | V | V | V | V | V | V |
| Cylinder Low | V | V | V | V | V | V | V | V |
| Cylinder High | V | V | V | V | V | V | V | V |
| Device/Head | - | - | - | - | H | H | H | H |
| Status | ...See Below... | | | | | | | |

| Error Register | | | | | | | |
|----------------|-----|---|-----|---|-----|-----|-----|
| 7 | 6 | 5 | 4 | 3 | 2 | 1 | 0 |
| CRC | UNC | 0 | IDN | 0 | ABT | TON | AMN |
| 0 | 0 | 0 | V | 0 | V | 0 | 0 |

| Status Register | | | | | | | |
|-----------------|-----|----|-----|-----|-----|-----|-----|
| 7 | 6 | 5 | 4 | 3 | 2 | 1 | 0 |
| BSY | RDY | DF | DSC | DRQ | COR | IDX | ERR |
| 0 | V | 0 | V | - | 0 | - | V |

Table 110 Format Track Command (50h)

The Format Track command formats a single logical track on the device. Each good sector of data on the track will be initialized to zero with write operation. At this time, whether the sector of data is initialized correctly is not verified with read operation. Any data previously stored on the track will be lost.

The host may transfer a sector of data containing a format table to the device. But the device ignores the format table and writes zero to all sectors on the track regardless of the descriptors.

Since device performance is optimal at 1:1 interleave, and the device uses relative block addressing internally, the device will always format a track in the same way no matter what sector numbering is specified in the format table.

Output Parameters To The Device

Sector Number In LBA mode, this register specifies LBA address bits 0 – 7 to be formatted. (L=1)

Cylinder High/Low The cylinder number of the track to be formatted. (L=0)
In LBA mode, this register specifies LBA address bits 8-15 (Low), 16-23 (High) to be formatted. (L=1)

H The head number of the track to be formatted. (L=0)
In LBA mode, this register specifies LBA address bits 24-27 to be formatted. (L=1)

Input Parameters From The Device

Sector Number In LBA mode, this register specifies current LBA address bits 0-7. (L=1)

Cylinder High/Low In LBA mode, this register specifies current LBA address bits 8-15 (Low), 16-23 (High)

H In LBA mode, this register specifies current LBA address bits 24-27. (L=1)

Error The Error Register. An Abort error (ABT=1) will be returned when LBA out of range.

In LBA mode, this command formats a single logical track including the specified LBA.

11.10 Format Unit (F7h)

| Command Block Output Registers | | | | | | | | |
|--------------------------------|---|---|---|---|---|---|---|---|
| Register | 7 | 6 | 5 | 4 | 3 | 2 | 1 | 0 |
| Data | - | - | - | - | - | - | - | - |
| Feature | 0 | 0 | 0 | 1 | 0 | 0 | 0 | 1 |
| Sector Count | - | - | - | - | - | - | - | - |
| Sector Number | - | - | - | - | - | - | - | - |
| Cylinder Low | - | - | - | - | - | - | - | - |
| Cylinder High | - | - | - | - | - | - | - | - |
| Device/Head | 1 | L | 1 | D | - | - | - | - |
| Command | 1 | 1 | 1 | 1 | 0 | 1 | 1 | 1 |

| Command Block Input Registers | | | | | | | | |
|-------------------------------|-----------------|---|---|---|---|---|---|---|
| Register | 7 | 6 | 5 | 4 | 3 | 2 | 1 | 0 |
| Data | - | - | - | - | - | - | - | - |
| Error | ...See Below... | | | | | | | |
| Sector Count | - | - | - | - | - | - | - | - |
| Sector Number | - | - | - | - | - | - | - | - |
| Cylinder Low | - | - | - | - | - | - | - | - |
| Cylinder High | - | - | - | - | - | - | - | - |
| Device/Head | - | - | - | - | - | - | - | - |
| Status | ...See Below... | | | | | | | |

| Error Register | | | | | | | |
|----------------|-----|---|-----|---|-----|-----|-----|
| 7 | 8 | 9 | 10 | 3 | 2 | 1 | 0 |
| CRC | UNC | 0 | IDN | 0 | ABT | T0N | AMN |
| 0 | V | 0 | V | 0 | V | 0 | 0 |

| Status Register | | | | | | | |
|-----------------|-----|----|-----|-----|-----|-----|-----|
| 7 | 6 | 5 | 4 | 3 | 2 | 1 | 0 |
| BSY | RDY | DF | DSC | DRQ | COR | IDX | ERR |
| 0 | V | 0 | V | 0 | 0 | - | V |

Table 111 Format Unit Command (F7h)

The Format Unit command initializes all user data sectors after merging reassigned sector location into the defect information of the device and clearing the reassign information. Both new reassign information and new defect information are available right after command completion of this command. Previous information of reassign and defect are erased from the device by executing this command.

Note that the Format Unit command initializes from LBA 0 to Native MAX LBA regardless of setting by Initialize Device Parameter (91h) command, Device Configuration Overlay, or Set Max Address (F9h) command, so the protected area defined by these commands is also initialized.

Security Erase Prepare (F3h) commands should be completed just prior to the Format Unit command. If the device receives a Format Unit command without a prior Security Erase Prepare command, the device aborts the Format Unit command.

All values in Feature register are reserved, and any values other than 11h should not be put into Feature register.

This command does not request to data transfer.

Command execution time depends on drive capacity. To determine command timeout value, Word 89 of Identify Device data should be referred.

The Format Unit command needs to complete successfully for the drive to be useable. If the command is interrupted by a reset, power down or unrecoverable error, the drive enters a degraded mode of operation in which reading or writing are prohibited. To exit the degraded mode, another Format Unit command must be sent by the host and completed successfully by the drive.

11.11 Identify Device (ECh)

| Command Block Output Registers | | | | | | | | |
|--------------------------------|---|---|---|---|---|---|---|---|
| Register | 7 | 6 | 5 | 4 | 3 | 2 | 1 | 0 |
| Data | - | - | - | - | - | - | - | - |
| Feature | - | - | - | - | - | - | - | - |
| Sector Count | - | - | - | - | - | - | - | - |
| Sector Number | - | - | - | - | - | - | - | - |
| Cylinder Low | - | - | - | - | - | - | - | - |
| Cylinder High | - | - | - | - | - | - | - | - |
| Device/Head | 1 | - | 1 | D | - | - | - | - |
| Command | 1 | 1 | 1 | 0 | 1 | 1 | 0 | 0 |

| Command Block Input Registers | | | | | | | | |
|-------------------------------|-----------------|---|---|---|---|---|---|---|
| Register | 7 | 6 | 5 | 4 | 3 | 2 | 1 | 0 |
| Data | - | - | - | - | - | - | - | - |
| Error | ...See Below... | | | | | | | |
| Sector Count | - | - | - | - | - | - | - | - |
| Sector Number | - | - | - | - | - | - | - | - |
| Cylinder Low | - | - | - | - | - | - | - | - |
| Cylinder High | - | - | - | - | - | - | - | - |
| Device/Head | - | - | - | - | - | - | - | - |
| Status | ...See Below... | | | | | | | |

| Error Register | | | | | | | |
|----------------|-----|---|-----|---|-----|-----|-----|
| 7 | 6 | 5 | 4 | 3 | 2 | 1 | 0 |
| CRC | UNC | 0 | IDN | 0 | ABT | T0N | AMN |
| 0 | 0 | 0 | 0 | 0 | V | 0 | 0 |

| Status Register | | | | | | | |
|-----------------|-----|----|-----|-----|-----|-----|-----|
| 7 | 6 | 5 | 4 | 3 | 2 | 1 | 0 |
| BSY | RDY | DF | DSC | DRQ | COR | IDX | ERR |
| 0 | V | 0 | - | - | 0 | - | V |

Table 112 Identify Device Command (ECh)

The Identify Device command requests the device to transfer configuration information to the host. The device will transfer a sector to the host containing the information described in the following pages.

| Word | Content | Description |
|-------|----------------------|--|
| 00 | 045AH or 045EH | Drive classification, bit assignments: 15 (=0): 1=ATAPI device, 0=ATA device 14-8 : retired 7 (=0): 1=removable cartridge device 6 (=1): 1=fixed device 5-3 : retired 2 (=0): Response incomplete 1 : retired 0 (=0): Reserved |
| 01 | xxxxH | Number of cylinders in default translate mode |
| 02 | C837H | Specific Configuration 37C8H: Need Set Feature for spin-up after power-up Identify Device is incomplete 738CH: Need Set Feature for spin-up after power-up Identify Device is complete 8C73H: No Need Set Feature for spin-up after power-up Identify Device is incomplete C837H: No Need Set Feature for spin-up after power-up Identify Device is complete |
| 03 | 00xxH | Number of heads in default translate mode |
| 04 | 0 * | Reserved |
| 05 | 0 * | Reserved |
| 06 | 003FH | Number of sectors per track in default translate mode |
| 07 | 0000H * | Number of bytes of sector gap |
| 08 | 0000H * | Number of bytes in sync field |
| 09 | 0000H * | Reserved |
| 10-19 | XXXX | Serial number in ASCII (0 = not specified) |
| 20 | 0003H * | Controller type: 0003: dual ported, multiple sector buffer with look-ahead read |
| 21 | XXXXH * | Buffer size in 512-byte increments. In case of 64MB buffer, it is set to 0x0000. |
| 22 | 0038H * | Reserved |
| 23-26 | XXXX | Microcode version in ASCII |
| 27-46 | XXXX | Model number in ASCII |
| 47 | 8010H | 15-8 : 80h 7-0 : Maximum number of sectors that can be transferred per interrupt on Read and Write Multiple commands |
| 48 | 400XH | Trusted Computing feature set options 15 (=0) : Shall be cleared to zero 14 (=1) : Shall be set to one 13-1 (=0) : Reserved for the Trusted Computing Group 0 (=0 or 1) : 0=Trusted Computing feature set is not supported 1=Trusted Computing feature set is supported |

Table 113 Identify Device Information

| Word | Content | Description |
|-------|---------|---|
| 49 | xF00H | Capabilities, bit assignments: 15-14 (=0) Reserved 13 Standby timer (=1) values as specified in ATA standard are supported (=0) values are vendor specific 12 (=0) Reserved 11 (=1) IORDY Supported 10 (=1) IORDY can be disabled 9 (=1) LBA supported 8 (=1) DMA supported 7- 0 (=0) Reserved |
| 50 | 4000H | Capabilities, bit assignments: 15-14 (=01) word 50 is valid 13- 1 (=0) Reserved 0 Minimum value of Standby timer (=0) less than 5 minutes |
| 51 | 0200H | PIO data transfer cycle timing mode |
| 52 | 0200H * | DMA data transfer cycle timing mode Refer Word 62 and 63 |
| 53 | 0007H | Validity flag of the word 15- 8 (=0): Free-fall Control Sensitivity 00h = Vendor's recommended setting 7-3 (=0): Reserved 2 (=1): 1=Word 88 is Valid 1 (=1): 1=Word 64-70 are Valid 0 (=1): 1=Word 54-58 are Valid |
| 54 | xxxxH | Number of current cylinders |
| 55 | xxxxH | Number of current heads |
| 56 | xxxxH | Number of current sectors per track |
| 57-58 | xxxxH | Current capacity in sectors Word 57 specifies the low word of the capacity |
| 59 | xxxxH | Sanitize capabilities and Current Multiple setting. Bit assignments 15 (=0) The BLOCK ERASE EXT command is supported 14 (=1) The OVERWRITE EXT command is supported 13 (=0or1) The CRYPTO SCRAMBLE EXT command is supported 12 (=1) The Sanitize Device Feature Set is supported 11(=1) The commands allowed during a sanitize operation 10-9 (=0) Reserved 8 1= Multiple Sector Setting is Valid 7-0 xxh = Current setting for number of sectors |
| 60-61 | xxxxH | Total Number of User Addressable Sectors Word 60 specifies the low word of the number FFFFFFFh=The 48-bit native max address is greater than 268,435,455 |
| 62 | 0000H | Reserved |
| 63 | xx07H | Multiword DMA Transfer Capability 15- 8 Multi word DMA transfer mode active 7-0 (=7) Multi word DMA transfer modes supported (support mode 0,1 and 2) |
| 64 | 0003H | Flow Control PIO Transfer Modes Supported 15-8 (=0) Reserved 7-0 (=3) Advanced PIO Transfer Modes Supported '11' = PIO Mode 3 and 4 Supported |

Table 114 Identify Device Information -Continued-

| Word | Content | Description |
|-------|----------------------|--|
| 65 | 0078H | Minimum Multiword DMA Transfer Cycle Time Per Word 15-0 (=78) Cycle time in nanoseconds (120ns, 16.6MB/s) |
| 66 | 0078H | Manufacturer's Recommended Multiword DMA Transfer Cycle Time 15-0 (=78) Cycle time in nanoseconds (120ns, 16.6MB/s) |
| 67 | 0078H | Minimum PIO Transfer Cycle Time Without Flow Control 15-0 (=78) Cycle time in nanoseconds (120ns, 16.6MB/s) |
| 68 | 0078H | Minimum PIO Transfer Cycle Time With IORDY Flow Control 15-0 (=78) Cycle time in nanoseconds (120ns, 16.6MB/s) |
| 69 | 0D08H or 0D18H | Additional Supported 11 (=1) READ BUFFER DMA command is supported 10 (=1) WRITE BUFFER DMA command is supported 8 (=1) DOWNLOAD MICROCODE DMA is supported 4 (=x) Encryption All User Data 3 (=1) Extended Number of User Addressable Sectors is supported |
| 70-74 | 0000H | Reserved |
| 75 | 001FH | Queue depth 15-5 (=0) Reserved 4-0 (=1F) Maximum queued depth – 1 |
| 76 | 970xH | SATA capabilities 15 (=1) READ LOG DMA EXT command is supported 14-13 (=0) Reserved 12 (=1) High Priority command (Please see 6.5 First-party DMA commands) 11 (=0) Unload while NCQ commands are outstanding is supported 10 (=1) Phy event counters 9 (=1) Receipt of host-initiated interface power management requests 8 (=1) Native Command Queuing supported 7-4 (=0) Reserved 3 (=x) SATA Gen-3 speed (6.0Gbps) supported 2 (=x) SATA Gen-2 speed (3.0Gbps) supported 1 (=1) SATA Gen-1 speed (1.5Gbps) supported 0 (=0) Reserved |
| 77 | 007xH | 15-8 (=0) Reserved 7 (=0) DevSleep_to_ReducedPwrState 6 (=1) Supports RECEIVE FPDMA QUEUED and SEND FPDMA QUEUED 5 (=1) Supports NCQ NON-DATA Command 4 (=1) Supports NCQ Streaming 3-1 (=011) Current negotiated SATA speed Gen-3 speed of 6.0Gbps (=010) Current negotiated SATA speed Gen-2 speed of 3.0Gbps (=001) Current negotiated SATA speed Gen-1 speed of 1.5Gbps 0(=0) Reserved |

Table 115 Identify Device Information -Continued-

| Word | Content | Description |
|------|---------|---|
| 78 | 0CDEH | SATA supported features 15-12 (=0) Reserved 11 (=1) Rebuild Assist 10 (=1) Device Initiated Interface Power Management Software Settings 9-8 (=0) Reserved 7 (=1) NCQ Autosense 6 (=1) Software setting preservation 5 (=0) Reserved 4 (=1) In-order data delivery 3 (=1) Device initiated interface power management 2 (=1) DMA Setup Auto-Activate optimization 1 (=1) Non-zero buffer offset in DMA Setup FIS 0 (=0) Reserved |
| 79 | 0040H | SATA enabled features 15-12 (=0) Reserved 11 (=0) Rebuild Assist enabled 10-9 (=0) Reserved 8-7 (=0) Reserved 6 (=1) Software setting preservation 5 (=0) Reserved 4 (=0) In-order data delivery 3 (=0) Device initiated interface power management 2 (=0) DMA Setup Auto-Activate optimization 1 (=0) Non-zero buffer offset in DMA Setup FIS 0 (=0) Reserved |
| 80 | 03FCH | Major version number 15-0 (=3FCh) ATA-2, ATA-3, ATA/ATAPI-4, ATA/ATAPI-5, ATA/ATAPI-6, ATA/ATAPI-7, ATA8-ACS, ACS-2 and ACS-3 |
| 81 | 0029H | Minor version number 15-0(=29h) ATA8-ACS Revision 4 |
| 82 | 746BH | Command 15 (=0) Reserved 14 (=1) NOP command 13 (=1) READ BUFFER command 12 (=1) WRITE BUFFER command 11 (=0) Reserved 10 (=1) Host Protected Area Feature Set 9 (=0) DEVICE RESET command 8 (=0) SERVICE interrupt 7 (=0) Release interrupt 6 (=1) LOOK AHEAD 5 (=1) WRITE CACHE 4 (=0) PACKET Command feature set 3 (=1) Power management feature set 2 (=0) Removable feature set 1 (=1) Security feature set 0 (=1) SMART feature Set |

Table 116 Identify Device Information -Continued-

| Word | Content | Description |
|------|----------------------|--|
| 83 | 7D69H | <p>Command set supported</p> <ul style="list-style-type: none"> 15-14 (=01) Word 83 is valid 13 (=1) FLUSH CACHE EXT command supported 12 (=1) FLUSH CACHE command supported 11 (=1) Device Configuration Overlay command supported 10 (=1) 48-bit Address feature set supported 9 (=0) Reserved 8 (=1) SET Max Security extension 7 (=0) Set Features Address Offset feature mode 6 (=1) SET FEATURES subcommand required to spin-up after power-up 5 (=1) Power-Up In Standby feature set supported 4 (=0) Removable Media Status Notification feature 3 (=1) Advanced Power Management feature set 2 (=0) CFA feature set 1 (=0) READ/WRITE DMA QUEUED 0 (=1) DOWNLOAD MICROCODE command |
| 84 | 4163H or 4773H | <p>Command set/feature supported extension</p> <ul style="list-style-type: none"> 15-14 (=01) Word 84 is valid 13 (=0) IDLE IMMEDIATE with UNLOAD FEATURE supported 12-11 (=0) Reserved 10 (=x) URG bit supported for WRITE STREAM DMA Ext and WRITE STREAM Ext 9 (=x) URG bit supported for READ STREAM DMA Ext and READ STREAM Ext 8 (=1) World wide name supported 7 (=0) WRITE DMA QUEUED FUA EXT command supported 6 (=1) WRITE DMA FUA EXT and WRITE MULTIPLE FUA EXT commands supported 5 (=1) General Purpose Logging feature set supported 4 (=x) Streaming feature set supported 3 (=0) Media Card Pass Through Command feature set supported 2 (=0) Media serial number supported 1 (=1) SMART self-test supported 0 (=1) SMART error logging supported |
| 85 | xxxxH | <p>Command set/feature enabled</p> <ul style="list-style-type: none"> 15 Reserved 14 NOP command 13 READ BUFFER command 12 WRITE BUFFER command 11 Reserved 10 Host Protected Area feature set 9 DEVICE RESET command 8 SERVICE interrupt 7 RELEASE interrupt 6 LOOK AHEAD 5 WRITE CACHE 4 PACKET Command feature set 3 Power management feature set 2 Removable media feature set 1 Security feature set 0 SMART feature set |

Table 117 Identify Device Information -Continued-

| Word | Content | Description |
|------|-------------------------------------|--|
| 86 | xxxxH | <p>Command set/feature enabled</p> <ul style="list-style-type: none"> 15 Words 120:119 are valid. 14 Reserved 13 FLUSH CACHE EXT command supported 12 FLUSH CACHE command supported 11 Device Configuration Overlay command enabled 10 48-bit Address features set supported 9 Reserved 8 Set Max Security extensions enabled 7 Set Features Address Offset mode 6 Set Features subcommand required to spin-up after power-up 5 Power-Up In Standby feature set enabled 4 Removable Media Status Notification feature 3 Advanced Power Management Feature set 2 CFA Feature set 1 READ/WRITE DMA QUEUED 0 DOWNLOAD MICROCODE command |
| 87 | 4163H or 4763H or 4773H | <p>Command set/feature default</p> <ul style="list-style-type: none"> 15-14 (=01) Word 87 is valid 13 (=0) IDLE IMMEDIATE with UNLOAD FEATURE supported 12-11 (=0) Reserved 10 (=x) URG bit supported for WRITE STREAM DMA Ext and WRITE STREAM Ext 9 (=x) URG bit supported for READ STREAM DMA Ext and READ STREAM Ext 8 (=1) World wide name supported 7 (=0) WRITE DMA QUEUED FUA EXT command supported 6 (=1) WRITE DMA FUA EXT and WRITE MULTIPLE FUA EXT commands supported 5 (=1) General Purpose Logging feature set supported 4 (=x) Valid CONFIGURE STREAM command has been executed 3 (=0) Media Card Pass Through Command feature set enabled 2 (=0) Media serial number is valid 1 (=1) SMART self-test supported 0 (=1) SMART error logging supported |

Table 118 Identify Device Information -Continued-

| Word | Content | Description |
|------|---------|---|
| 88 | xx7FH | <p>Ultra DMA Transfer modes</p> <p>15- 8 (=xx) Current active Ultra DMA transfer mode</p> <p>15 Reserved (=0)</p> <p>14 Mode 6 1 = Active 0 = Not Active</p> <p>13 Mode 5 1 = Active 0 = Not Active</p> <p>12 Mode 4 1 = Active 0 = Not Active</p> <p>11 Mode 3 1 = Active 0 = Not Active</p> <p>10 Mode 2 1 = Active 0 = Not Active</p> <p>9 Mode 1 1 = Active 0 = Not Active</p> <p>8 Mode 0 1 = Active 0 = Not Active</p> <p>7- 0 (=7F) Ultra DMA Transfer mode supported</p> <p>7 Reserved (=0)</p> <p>6 Mode 6 1 = Support</p> <p>5 Mode 5 1 = Support</p> <p>4 Mode 4 1 = Support</p> <p>3 Mode 3 1 = Support</p> <p>2 Mode 2 1 = Support</p> <p>1 Mode 1 1 = Support</p> <p>0 Mode 0 1 = Support</p> |
| 89 | xxxxH | <p>15 1=Extended Time is reported in bits 14:0 0=Time is reported in bits 7:0</p> <p>If bit 15 is set to one</p> <p>14:0 Time required for security erase unit completion Time= value(xxxxh)*2 [minutes]</p> <p>If bit 15 is set to zero</p> <p>14:8 Reserved</p> <p>7:0 Time required for security erase unit completion Time= value(xxxxh)*2 [minutes]</p> |
| 90 | xxxxH | <p>15 1=Extended Time is reported in bits 14:0 0=Time is reported in bits 7:0</p> <p>If bit 15 is set to one</p> <p>14:0 Time required for Enhanced security erase completion</p> <p>If bit 15 is set to zero</p> <p>14:8 Reserved</p> <p>7:0 Time required for Enhanced security erase completion</p> |
| 91 | 00FEH | Current Advanced power management value |
| 92 | FFFEH | Current Password Revision Code |
| 93 | 0000H | COMRESET result |
| 94 | 0000H | Reserved |
| 95 | xxxxH | <p>Stream Minimum Request Size</p> <p>Number of sectors that provides optimum performance in streaming environment. This number shall be a power of two, with a minimum of eight sectors (4096 bytes). The starting LBA value for each streaming command should be evenly divisible by this request size.</p> |
| 96 | xxxxH | <p>Streaming Transfer Time – DMA</p> <p>The worst-case sustainable transfer time per sector for the device is calculated as follows:</p> <p>Streaming Transfer Time = (word 96) * (words(99:98) / 65536)</p> <p>If the Streaming Feature set is not supported by the device, the content of word 96 shall be zero.</p> |

Table 119 Identify Device Information -Continued-

| Word | Content | Description |
|---------|---------|--|
| 97 | xxxxH | Streaming Access Latency – DMA and PIO The worst-case access latency of the device for a streaming command is calculated as follows: Access Latency = (word 97) * (words(99:98) / 256) If the Streaming Feature set is not supported by the device, the content of word 97 shall be zero. |
| 98 | xxxxH | Streaming Performance Granularity |
| 99 | xxxxH | Streaming Performance Granularity |
| 100-103 | xxxxH | Total Number of User Addressable Logical Sectors for 48-bit commands |
| 104 | xxxxH | Streaming Transfer Time – PIO The worst-case sustainable transfer time per sector for the device is calculated as follows: Streaming Transfer Time = (word 104) * (words(99:98) / 65536) If the Streaming Feature set is not supported by the device, the content of word 104 shall be zero. |
| 105 | 0000H | Reserved |
| 106 | 6003H | Physical sector size / logical sector size 15 Shall be cleared to zero 14 Shall be set to one. 13 0=Device does not have multiple logical sectors per physical sector 12 0=Device logical sector is 256 words 11-4 Reserved 3-0 0=2^0 logical sectors per physical sector |
| 107 | 5A87H | Inter-seek delay for ISO-7779 acoustic testing in microseconds |
| 108-111 | xxxxH | World wide name the optional value of the world wide name for the device |
| 112-116 | 0000H | Reserved |
| 117-118 | xxxxH | Logical Sector Size (Dword) |
| 119 | 40DCh | Supported settings (Continued from word 84:82) 15 Shall be cleared to zero 14 Shall be set to one. 13-8 Reserved 7 1=Extended Power Conditions feature set is supported 6 1=Sense data is supported 5 0=Free-fall Control feature set is not supported 4 1=The segmented feature for download microcode is supported. 3 1=The READ/ WRITE LOG DMA EXT commands are supported. 2 1=Write Uncorrectable is supported. 1 0=Write-Read-Verify feature set is not supported 0 Reserved |
| 120 | 409Ch | Command set/feature enabled/supported. (Continued from word 87:85) 15 Shall be cleared to zero 14 Shall be set to one. 13-8 Reserved 7 1=Extended Power Conditions feature set is enabled 6 0=Sense data is disabled 5 0=Free-fall Control feature set is disabled 4 1=The segmented feature for download microcode is supported. 3 1=The READ/ WRITE LOG DMA EXT commands are supported. 2 1=Write Uncorrectable is supported. 1 0=Write-Read-Verify feature set is not enabled 0 Reserved |

Table 120 Identify Device Information -Continued-

| Word | Content | Description |
|---------|---------|--|
| 121-126 | 0000H | Reserved |
| 127 | 0000H | Removable Media Status Notification feature set 0000H=Not supported |
| 128 | xxxxH | Security status. Bit assignments 15-9 Reserved 8 Security Level 1= Maximum, 0= High 7-6 Reserved 5 Enhanced erase 1= Support 4 Expired 1= Expired 3 Freeze 1= Frozen 2 Lock 1= Locked 1 Enabled/Disable 1= Enable 0 Capability 1= Support |
| 129 | xxxxH * | Current Set Feature Option. Bit assignments 15-4 Reserved 3 Auto reassign enabled 1= Enable 2 Reverting enabled 1= Enable 1 Read Look-ahead enabled 1= Enable 0 Write Cache enabled 1= Enable |
| 130-159 | xxxxH * | Reserved |
| 160-167 | 0000H | Reserved |
| 168 | 0002H | 15-4 Reserved 3-0 Device Nominal Form Factor 02H shows 3.5inch nominal form factor |
| 169-175 | 0000H | Reserved |
| 176-205 | 0000H | Current media serial number (0000H=Not supported) |
| 206 | 003DH | SCT Command set support 15-12 Vendor specific 11-6 Reserved 5 Action Code 5 (SCT Data Table) 1= Support 4 Action Code 4 (Features Control) 1= Support 3 Action Code 3 (Error Recovery Control) 1= Support 2 Action Code 2 (SCT Write Same) 1= Support 1 Action Code 1 (Long Sector Access) 0= Not Support 0 SCT Feature Set (includes SCT status) 1= Support |

Table 121 Identify Device Information -Continued-

Note. The '*' mark in 'Content' field indicates the use of those parameters are vendor specific.

| Word | Content | Description |
|---------|-------------------------------------|---|
| 207-208 | 0000H | Reserved |
| 209 | 4000H or 0000H | Alignment of logical blocks within a physical block (This word is valid if bit 13 of word 106 is set to one.) 15 Shall be cleared to zero 14 Shall be set to one 13-0 Logical sector offset within the first physical sector where the first logical sector is placed |
| 210-211 | 0000H | Write-Read-Verify Sector Count Mode 3 (Dword) 0000H=Not supported |
| 212-213 | 0000H | Write-Read-Verify Sector Count Mode 2 (Dword) 0000H=Not supported |
| 214 | 0000H | NV Cache Capabilities 0000H=Not supported |
| 215-216 | 0000H | NV Cache Size in Logical Blocks (Dword) |
| 217 | 1C20H or 1644H or 1734H | Nominal media rotation rate (=7200rpm) |
| 218 | 0000H | Reserved |
| 219 | 0000H | NV Cache Options 0000H=Not supported |
| 220 | 0000H | 15-8 (=0) Reserved 7-0 (=0) Write-Read-Verify feature set current mode(not supported) |
| 221 | 0000H | Reserved |
| 222 | 10FFH | Transport major version number 15-12 (=1) Transport Type (1= Serial) 11-8 (=0) Reserved 7 (=1) SATA Rev 3.2 6 (=1) SATA Rev 3.1 5 (=1) SATA Rev 3.0 4 (=1) SATA Rev 2.6 3 (=1) SATA Rev 2.5 2 (=1) SATA II: Extensions 1 (=1) SATA 1.0a 0 (=1) ATA8-AST |
| 223 | 0021H | Transport minor version number (ATA8-AST T13 Project D1697 Revision 0b) |
| 224-229 | 0000H | Reserved |
| 230-233 | xxxxH | Extended Number of User Addressable Sectors |
| 234 | 0008H | Minimum number of 512-byte data blocks per DOWNLOAD MICROCODE command for mode 3 |
| 235 | 0000H | Maximum number of 512-byte data blocks per DOWNLOAD MICROCODE command for mode 3 |
| 236-254 | 0000H | Reserved |
| 255 | xxA5H | 15-8 Checksum. This value is the two's complement of the sum of all bytes in byte 0 through 510 7-0 (A5) Signature |

Table 122 Identify Device Information -Continued-

11.12 Idle (E3h/97h)

| Command Block Output Registers | | | | | | | | |
|--------------------------------|---|---|---|---|---|---|---|---|
| Register | 7 | 6 | 5 | 4 | 3 | 2 | 1 | 0 |
| Data | - | - | - | - | - | - | - | - |
| Feature | - | - | - | - | - | - | - | - |
| Sector Count | V | V | V | V | V | V | V | V |
| Sector Number | - | - | - | - | - | - | - | - |
| Cylinder Low | - | - | - | - | - | - | - | - |
| Cylinder High | - | - | - | - | - | - | - | - |
| Device/Head | 1 | - | 1 | D | - | - | - | - |
| Command | 1 | 1 | 1 | 0 | 0 | 0 | 1 | 1 |

| Command Block Input Registers | | | | | | | | |
|-------------------------------|-----------------|---|---|---|---|---|---|---|
| Register | 7 | 6 | 5 | 4 | 3 | 2 | 1 | 0 |
| Data | - | - | - | - | - | - | - | - |
| Error | ...See Below... | | | | | | | |
| Sector Count | - | - | - | - | - | - | - | - |
| Sector Number | - | - | - | - | - | - | - | - |
| Cylinder Low | - | - | - | - | - | - | - | - |
| Cylinder High | - | - | - | - | - | - | - | - |
| Device/Head | - | - | - | - | - | - | - | - |
| Status | ...See Below... | | | | | | | |

| Error Register | | | | | | | |
|----------------|-----|---|-----|---|-----|-----|-----|
| 7 | 6 | 5 | 4 | 3 | 2 | 1 | 0 |
| CRC | UNC | 0 | IDN | 0 | ABT | T0N | AMN |
| 0 | 0 | 0 | 0 | 0 | V | 0 | 0 |

| Status Register | | | | | | | |
|-----------------|-----|----|-----|-----|-----|-----|-----|
| 7 | 6 | 5 | 4 | 3 | 2 | 1 | 0 |
| BSY | RDY | DF | DSC | DRQ | COR | IDX | ERR |
| 0 | V | 0 | V | - | 0 | - | V |

Table 123 Idle Command (E3h/97h)

The Idle command causes the device to enter Idle mode immediately, and set auto power down timeout parameter (standby timer). And then the timer starts counting down.

When the Idle mode is entered, the device is spun up to operating speed. If the device is already spinning, the spin up sequence is not executed.

During Idle mode the device is spinning and ready to respond to host commands immediately.

Output Parameters To The Device

Sector Count Timeout Parameter. If zero, then the automatic power down sequence is disabled. If non-zero, then the automatic power down sequence is enabled, and the timeout interval is shown below:

| Value | Description |
|---------|--------------------------|
| 0 | Timer disabled |
| 1-240 | Value * 5 |
| 241-251 | (Value-240) * 30 minutes |
| 252 | 21 minutes |
| 253 | 8 hours |
| 254 | Aborted |
| 255 | 21 minutes 15 seconds |

When the automatic power down sequence is enabled, the drive will enter Standby mode automatically if the timeout interval expires with no drive access from the host. The timeout interval will be reinitialized if there is a drive access before the timeout interval expires.

11.13 Idle Immediate (E1h/95h)

| Command Block Output Registers | | | | | | | | |
|--------------------------------|---|---|---|---|---|---|---|---|
| Register | 7 | 6 | 5 | 4 | 3 | 2 | 1 | 0 |
| Data | - | - | - | - | - | - | - | - |
| Feature | - | - | - | - | - | - | - | - |
| Sector Count | - | - | - | - | - | - | - | - |
| Sector Number | - | - | - | - | - | - | - | - |
| Cylinder Low | - | - | - | - | - | - | - | - |
| Cylinder High | - | - | - | - | - | - | - | - |
| Device/Head | 1 | - | 1 | D | - | - | - | - |
| Command | 1 | 1 | 1 | 0 | 0 | 0 | 0 | 1 |

| Command Block Input Registers | | | | | | | | |
|-------------------------------|-----------------|---|---|---|---|---|---|---|
| Register | 7 | 6 | 5 | 4 | 3 | 2 | 1 | 0 |
| Data | - | - | - | - | - | - | - | - |
| Error | ...See Below... | | | | | | | |
| Sector Count | - | - | - | - | - | - | - | - |
| Sector Number | - | - | - | - | - | - | - | - |
| Cylinder Low | - | - | - | - | - | - | - | - |
| Cylinder High | - | - | - | - | - | - | - | - |
| Device/Head | - | - | - | - | - | - | - | - |
| Status | ...See Below... | | | | | | | |

| Error Register | | | | | | | |
|----------------|-----|---|-----|---|-----|-----|-----|
| 7 | 6 | 5 | 4 | 3 | 2 | 1 | 0 |
| CRC | UNC | 0 | IDN | 0 | ABT | T0N | AMN |
| 0 | 0 | 0 | 0 | 0 | V | 0 | 0 |

| Status Register | | | | | | | |
|-----------------|-----|----|-----|-----|-----|-----|-----|
| 7 | 6 | 5 | 4 | 3 | 2 | 1 | 0 |
| BSY | RDY | DF | DSC | DRQ | COR | IDX | ERR |
| 0 | V | 0 | V | - | 0 | - | V |

Table 124 Idle Immediate Command (E1h/95h)

The Idle Immediate command causes the device to enter Idle mode.

The device is spun up to operating speed. If the device is already spinning, the spin up sequence is not executed.

During Idle mode the device is spinning and ready to respond to host commands immediately.

The Idle Immediate command will not affect to auto power down timeout parameter.

11.14 Initialize Device Parameters (91h)

| Command Block Output Registers | | | | | | | | Command Block Input Registers | | | | | | | | | |
|--------------------------------|---|---|---|---|---|---|---|-------------------------------|---------------|-----------------|---|---|---|---|---|---|---|
| Register | 7 | 6 | 5 | 4 | 3 | 2 | 1 | 0 | Register | 7 | 6 | 5 | 4 | 3 | 2 | 1 | 0 |
| Data | - | - | - | - | - | - | - | - | Data | - | - | - | - | - | - | - | - |
| Feature | - | - | - | - | - | - | - | - | Error | - | - | - | - | - | - | - | - |
| Sector Count | V | V | V | V | V | V | V | V | Sector Count | - | - | - | - | - | - | - | - |
| Sector Number | - | - | - | - | - | - | - | - | Sector Number | - | - | - | - | - | - | - | - |
| Cylinder Low | - | - | - | - | - | - | - | - | Cylinder Low | - | - | - | - | - | - | - | - |
| Cylinder High | - | - | - | - | - | - | - | - | Cylinder High | - | - | - | - | - | - | - | - |
| Device/Head | 1 | - | 1 | D | H | H | H | H | Device/Head | - | - | - | - | - | - | - | - |
| Command | 1 | 0 | 0 | 1 | 0 | 0 | 0 | 1 | Status | ...See Below... | | | | | | | |

| Error Register | | | | | | | | Status Register | | | | | | | |
|----------------|-----|---|-----|---|-----|-----|-----|-----------------|-----|----|-----|-----|-----|-----|-----|
| 7 | 6 | 5 | 4 | 3 | 2 | 1 | 0 | 7 | 6 | 5 | 4 | 3 | 2 | 1 | 0 |
| CRC | UNC | 0 | IDN | 0 | ABT | TON | AMN | BSY | RDY | DF | DSC | DRQ | COR | IDX | ERR |
| 0 | 0 | 0 | 0 | 0 | V | 0 | 0 | 0 | V | 0 | - | - | 0 | - | V |

Table 125 Initialize Device Parameters Command (91h)

The Initialize Device Parameters command enables the host to set the number of sectors per track and the number of heads minus 1, per cylinder. Words 54-58 in Identify Device Information reflect these parameters.

The parameters remain in effect until following events:

- Another Initialize Device Parameters command is received.
- The device is powered off.
- Soft reset occurs and the Set Feature option of CCh is set instead of 66h.

Output Parameters To The Device

Sector Count The number of sectors per track. 0 does not mean there are 256 sectors per track, but there is no sector per track.

H The number of heads minus 1 per cylinder. The minimum is 0 and the maximum is 15.

Note:

The following conditions needs to be satisfied to avoid invalid number of cylinders beyond FFFFh.

$(\text{Total number of user addressable sectors}) / ((\text{Sector Count}) * (\text{H} + 1)) = < \text{FFFFh}$

The total number of user addressable sectors is described in Identify Device command.

11.15 NCQ NON-DATA (63h)

| Command Block Output Registers | | | | | | | | |
|--------------------------------|----------|---|---|---|---|---|---|---|
| Register | 7 | 6 | 5 | 4 | 3 | 2 | 1 | 0 |
| Data Low | - | - | - | - | - | - | - | - |
| Data High | - | - | - | - | - | - | - | - |
| Feature | Current | V | V | V | V | V | V | V |
| | Previous | - | - | - | - | - | - | - |
| Sector Count | Current | V | V | V | V | - | - | - |
| | Previous | V | V | - | - | - | - | - |
| Sector Number | Current | V | V | V | V | - | - | - |
| | Previous | - | - | - | - | - | - | - |
| Cylinder Low | Current | - | - | - | - | - | - | - |
| | Previous | - | - | - | - | - | - | - |
| Cylinder High | Current | - | - | - | - | - | - | - |
| | Previous | - | - | - | - | - | - | - |
| Device/Head | - | 1 | - | 0 | - | - | - | - |
| Command | 0 | 1 | 1 | 0 | 0 | 0 | 1 | 1 |

| Command Block Input Registers | | | | | | | | |
|-------------------------------|-----------------|---|---|---|---|---|---|---|
| Register | 7 | 6 | 5 | 4 | 3 | 2 | 1 | 0 |
| Data Low | - | - | - | - | - | - | - | - |
| Data High | - | - | - | - | - | - | - | - |
| Error | ...See Below... | | | | | | | |
| Sector Count | HOB=0 | - | - | - | - | - | - | - |
| | HOB=1 | - | - | - | - | - | - | - |
| Sector Number | HOB=0 | - | - | - | - | - | - | - |
| | HOB=1 | - | - | - | - | - | - | - |
| Cylinder Low | HOB=0 | - | - | - | - | - | - | - |
| | HOB=1 | - | - | - | - | - | - | - |
| Cylinder High | HOB=0 | - | - | - | - | - | - | - |
| | HOB=1 | - | - | - | - | - | - | - |
| Device/Head | - | - | - | - | - | - | - | - |
| Status | ...See Below... | | | | | | | |

| Error Register | | | | | | | |
|----------------|-----|---|-----|---|-----|-----|-----|
| 7 | 6 | 5 | 4 | 3 | 2 | 1 | 0 |
| CRC | UNC | 0 | IDN | 0 | ABT | T0N | AMN |
| V | V | 0 | V | 0 | V | 0 | 0 |

| Status Register | | | | | | | |
|-----------------|-----|----|-----|-----|-----|-----|-----|
| 7 | 6 | 5 | 4 | 3 | 2 | 1 | 0 |
| BSY | RDY | DF | DSC | DRQ | COR | IDX | ERR |
| 0 | V | 0 | V | - | 0 | - | V |

Table 126 NCQ NON-DATA Command (63h)

Table 42 defines the NCQ NON-DATA subcommands. See the referenced sections for additional information in this table.

The output from the host to the device, the command acceptance outputs for this command, the normal outputs for this command and the error outputs for this command are subcommand specific. See 11.15.1 Abort NCQ Queue Subcommand (0h) and 11.15.2 Deadline Handling Subcommand (1h).

11.15.1 Abort NCQ Queue Subcommand (0h)

| Command Block Output Registers | | | | | | | | |
|--------------------------------|----------|---|---|---|---|---|---|---|
| Register | 7 | 6 | 5 | 4 | 3 | 2 | 1 | 0 |
| Data Low | - | - | - | - | - | - | - | - |
| Data High | - | - | - | - | - | - | - | - |
| Feature | Current | V | V | V | V | 0 | 0 | 0 |
| | Previous | - | - | - | - | - | - | - |
| Sector Count | Current | V | V | V | V | - | - | - |
| | Previous | - | - | - | - | - | - | - |
| Sector Number | Current | V | V | V | V | - | - | - |
| | Previous | - | - | - | - | - | - | - |
| Cylinder Low | Current | - | - | - | - | - | - | - |
| | Previous | - | - | - | - | - | - | - |
| Cylinder High | Current | - | - | - | - | - | - | - |
| | Previous | - | - | - | - | - | - | - |
| Device/Head | - | 1 | - | 0 | - | - | - | - |
| Command | 0 | 1 | 1 | 0 | 0 | 0 | 1 | 1 |

| Command Block Input Registers | | | | | | | | |
|-------------------------------|-----------------|---|---|---|---|---|---|---|
| Register | 7 | 6 | 5 | 4 | 3 | 2 | 1 | 0 |
| Data Low | - | - | - | - | - | - | - | - |
| Data High | - | - | - | - | - | - | - | - |
| Error | ...See Below... | | | | | | | |
| Sector Count | HOB=0 | - | - | - | - | - | - | - |
| | HOB=1 | - | - | - | - | - | - | - |
| Sector Number | HOB=0 | - | - | - | - | - | - | - |
| | HOB=1 | - | - | - | - | - | - | - |
| Cylinder Low | HOB=0 | - | - | - | - | - | - | - |
| | HOB=1 | - | - | - | - | - | - | - |
| Cylinder High | HOB=0 | - | - | - | - | - | - | - |
| | HOB=1 | - | - | - | - | - | - | - |
| Device/Head | - | - | - | - | - | - | - | - |
| Status | ...See Below... | | | | | | | |

| Error Register | | | | | | | |
|----------------|-----|---|-----|---|-----|-----|-----|
| 7 | 6 | 5 | 4 | 3 | 2 | 1 | 0 |
| CRC | UNC | 0 | IDN | 0 | ABT | TON | AMN |
| V | V | 0 | V | 0 | V | 0 | 0 |

| Status Register | | | | | | | |
|-----------------|-----|----|-----|-----|-----|-----|-----|
| 7 | 6 | 5 | 4 | 3 | 2 | 1 | 0 |
| BSY | RDY | DF | DSC | DRQ | COR | IDX | ERR |
| 0 | V | 0 | V | - | 0 | - | V |

Table 127 Abort NCQ Queue Subcommand (0h)

Normal Outputs

If a supported Abort Type parameter is specified, then the device indicates success, even if the command results in no commands being aborted.

When an Abort NCQ Queue command completes successfully, a Set Device Bits FIS is sent to the host to complete the Abort subcommand and commands that were aborted as a consequence of the Abort subcommand by setting the ACT bits for those commands to one. This SDB FIS may also indicate other completed commands.

Error Outputs

The device returns command aborted if:

- NCQ is disabled and an Abort NCQ Queue command is issued to the device;
- the value of the TTAG field equals the value of the TAG field;
- the value of the TTAG field is an invalid TAG number; or
- an unsupported Abort type parameter is specified.

Output Parameters To The Device

Feature Current

- Subcommand (bits 3-0)** When bits(3:0) is 0h, Abort NCQ Queue Abort Subcommand.
- Subcommand Specific (bits 7-4)** Abort Type, bit(7:4), describes the action requested. The NCQ NON-DATA Log (see 9.17.4.3 Read Log Ext Log Page 12h) provides a list of abort types supported by the device. The value of Abort type are defined in the below the table.

Feature Previous

Sector Count Current

- TAG (bits 7-3)** The TAG value is assigned to be different from all other queued commands. The value does not exceed the maximum queue depth specified by the Word 75 of the Identify Device information.

Sector Count Previous

Sector Number Current

- TTAG (bits 7-3)** The TTAG field contains the value of the TAG of the outstanding command that is requested to be aborted. The TTAG value is only valid when the Abort Type field is set to 3h (Abort Selected). TTAG does not exceed the value specified in IDENTIFY DEVICE word 75.

Cylinder Low Current

Cylinder Low Previous

Cylinder High Current

Cylinder High Previous

Device/Head

Input Parameters From The Device

Sector Number (HOB=0)

Sector Number (HOB=1)

Cylinder Low (HOB=0)

Cylinder Low (HOB=1)

Cylinder High (HOB=0)

Cylinder High (HOB=1)

| Abort Type Parameters | | |
|-----------------------|---------------------|---|
| Abort Type | Abort Type | Description |
| 0h | Abort All | The device attempts to abort all outstanding NCQ commands. |
| 1h | Abort Streaming | The device attempts to abort all outstanding NCQ Streaming commands. All non-streaming NCQ commands are unaffected. |
| 2h | Abort Non-Streaming | The device attempts to abort all outstanding NCQ Non-Streaming commands. All NCQ Streaming commands are unaffected. |
| 3h | Abort Selected | The device attempts to abort the outstanding NCQ command associated with the tag represented in TTAG field. |

Table 128 Abort Type Field

11.15.2 Deadline Handling Subcommand (1h)

| Command Block Output Registers | | | | | | | | |
|--------------------------------|----------|---|---|---|---|---|---|---|
| Register | 7 | 6 | 5 | 4 | 3 | 2 | 1 | 0 |
| Data Low | - | - | - | - | - | - | - | - |
| Data High | - | - | - | - | - | - | - | - |
| Feature | Current | - | - | V | V | 0 | 0 | 1 |
| | Previous | - | - | - | - | - | - | - |
| Sector Count | Current | V | V | V | V | - | - | - |
| | Previous | - | - | - | - | - | - | - |
| Sector Number | Current | V | V | V | V | - | - | - |
| | Previous | - | - | - | - | - | - | - |
| Cylinder Low | Current | - | - | - | - | - | - | - |
| | Previous | - | - | - | - | - | - | - |
| Cylinder High | Current | - | - | - | - | - | - | - |
| | Previous | - | - | - | - | - | - | - |
| Device/Head | - | 1 | - | 0 | - | - | - | - |
| Command | 0 | 1 | 1 | 0 | 0 | 0 | 1 | 1 |

| Command Block Input Registers | | | | | | | | |
|-------------------------------|-----------------|---|---|---|---|---|---|---|
| Register | 7 | 6 | 5 | 4 | 3 | 2 | 1 | 0 |
| Data Low | - | - | - | - | - | - | - | - |
| Data High | - | - | - | - | - | - | - | - |
| Error | ...See Below... | | | | | | | |
| Sector Count | HOB=0 | - | - | - | - | - | - | - |
| | HOB=1 | - | - | - | - | - | - | - |
| Sector Number | HOB=0 | - | - | - | - | - | - | - |
| | HOB=1 | - | - | - | - | - | - | - |
| Cylinder Low | HOB=0 | - | - | - | - | - | - | - |
| | HOB=1 | - | - | - | - | - | - | - |
| Cylinder High | HOB=0 | - | - | - | - | - | - | - |
| | HOB=1 | - | - | - | - | - | - | - |
| Device/Head | - | - | - | - | - | - | - | - |
| Status | ...See Below... | | | | | | | |

| Error Register | | | | | | | |
|----------------|-----|---|-----|---|-----|-----|-----|
| 7 | 6 | 5 | 4 | 3 | 2 | 1 | 0 |
| CRC | UNC | 0 | IDN | 0 | ABT | TON | AMN |
| V | V | 0 | V | 0 | V | 0 | 0 |

| Status Register | | | | | | | |
|-----------------|-----|----|-----|-----|-----|-----|-----|
| 7 | 6 | 5 | 4 | 3 | 2 | 1 | 0 |
| BSY | RDY | DF | DSC | DRQ | COR | IDX | ERR |
| 0 | V | 0 | V | - | 0 | - | V |

Table 129 Deadline handling Subcommand (1h)

Normal Outputs

If this Deadline Handling Subcommand command is supported, the device returns the command completed with no error.

When a Deadline Handling Subcommand command completes successfully, a Set Device Bits FIS is sent to the host to complete the Deadline Handling subcommand. This SDB FIS may also indicate other completed commands.

Error Outputs

The device returns command aborted, if:

- NCQ is disabled and a DEADLINE HANDLING command is issued to the device;
- The value of the TTAG field equals the value of the TAG field;
- The value of the TTAG field is an invalid TAG number; or
- An unsupported Abort type parameter is specified.

Output Parameters To The Device

Feature Current

- Subcommand (bits 3-0)** When bits (3:0) is 1h, Deadline Handling Subcommand.
- WDNC(bits 4)** If the WDNC (Write Data Not Continue) bit is cleared to zero, then the device allows WRITE FPDMA QUEUED command completion times to exceed what the ICC parameter specified. If the WDNC bit is set to one, then the all WRITE FPDMA QUEUED commands are completed by the time specified by the ICC timer value, otherwise the device returns command aborted for all outstanding commands. WDNC is only applicable to WRITE FPDMA QUEUED commands with PRIO is set to 01b (Isochronous – deadline dependent priority)
- RDNC(bits 5)** If the RDNC (Read Data Not Continue) bit is cleared to zero, then the device allows READ FPDMA QUEUED command completion times to exceed what the ICC parameter specified. If the RDNC bit is set to one, then the all READ FPDMA QUEUED commands are completed by the time specified by the ICC timer value, otherwise the device returns command aborted for all outstanding commands. RDNC is only applicable to READ FPDMA QUEUED commands with PRIO is set to 01b (Isochronous – deadline dependent priority)

Feature Previous

Sector Count Current

- TAG (bits 7-3)** The TAG value is assigned to be different from all other queued commands. The value does not exceed the maximum queue depth specified by the Word 75 of the Identify Device information.

Sector Count Previous

Sector Number Current

Cylinder Low Current

Cylinder Low Previous

Cylinder High Current

Cylinder High Previous

Device/Head

Input Parameters From The Device

Sector Number (HOB=0)

Sector Number (HOB=1)

Cylinder Low (HOB=0)

Cylinder Low (HOB=1)

Cylinder High (HOB=0)

Cylinder High (HOB=1)

11.15.3 Set Features Subcommand (5h)

| Command Block Output Registers | | | | | | | | | |
|--------------------------------|----------|---|---|---|---|---|---|---|---|
| Register | 7 | 6 | 5 | 4 | 3 | 2 | 1 | 0 | |
| Data Low | - | - | - | - | - | - | - | - | |
| Data High | - | - | - | - | - | - | - | - | |
| Feature | Current | - | - | V | V | 0 | 1 | 0 | 1 |
| | Previous | - | - | - | - | - | - | - | - |
| Sector Count | Current | V | V | V | V | V | - | - | - |
| | Previous | - | - | - | - | - | - | - | - |
| Sector Number | Current | V | V | V | V | V | - | - | - |
| | Previous | - | - | - | - | - | - | - | - |
| Cylinder Low | Current | - | - | - | - | - | - | - | |
| | Previous | - | - | - | - | - | - | - | |
| Cylinder High | Current | - | - | - | - | - | - | - | |
| | Previous | - | - | - | - | - | - | - | |
| Device/Head | - | 1 | - | 0 | - | - | - | - | |
| Command | 0 | 1 | 1 | 0 | 0 | 0 | 1 | 1 | |

| Command Block Input Registers | | | | | | | | |
|-------------------------------|-----------------|---|---|---|---|---|---|---|
| Register | 7 | 6 | 5 | 4 | 3 | 2 | 1 | 0 |
| Data Low | - | - | - | - | - | - | - | - |
| Data High | - | - | - | - | - | - | - | - |
| Error | ...See Below... | | | | | | | |
| Sector Count | HOB=0 | - | - | - | - | - | - | - |
| | HOB=1 | - | - | - | - | - | - | - |
| Sector Number | HOB=0 | - | - | - | - | - | - | - |
| | HOB=1 | - | - | - | - | - | - | - |
| Cylinder Low | HOB=0 | - | - | - | - | - | - | - |
| | HOB=1 | - | - | - | - | - | - | - |
| Cylinder High | HOB=0 | - | - | - | - | - | - | - |
| | HOB=1 | - | - | - | - | - | - | - |
| Device/Head | - | - | - | - | - | - | - | - |
| Status | ...See Below... | | | | | | | |

| Error Register | | | | | | | |
|----------------|-----|---|-----|---|-----|-----|-----|
| 7 | 6 | 5 | 4 | 3 | 2 | 1 | 0 |
| CRC | UNC | 0 | IDN | 0 | ABT | T0N | AMN |
| V | V | 0 | V | 0 | V | 0 | 0 |

| Status Register | | | | | | | |
|-----------------|-----|----|-----|-----|-----|-----|-----|
| 7 | 6 | 5 | 4 | 3 | 2 | 1 | 0 |
| BSY | RDY | DF | DSC | DRQ | COR | IDX | ERR |
| 0 | V | 0 | V | - | 0 | - | V |

Table 130 SET FEATURES Subcommand (5h)

Normal Outputs

Upon successful completion of one or more outstanding commands, the device shall transmit a Set Device Bits FIS with the Interrupt bit set to one and one or more bits set to one in the ACT field corresponding to the bit position for each command TAG that has completed since the last status notification was transmitted. The ERR bit in the Status register shall be cleared to zero and the value in the Error register shall be zero.

Error Outputs

If the device has received a command that has not yet been acknowledged by clearing the BSY bit to zero and an error is encountered, the device shall transmit a Register Device to Host FIS (see Table 130) with the ERR bit set to one and the BSY bit cleared to zero in the Status field, the ATA error code in the Error field.

Output Parameters To The Device

Feature Current

Subcommand (bits 3-0) When bits(3:0) is 5h, SET FEATURES Subcommand.

**Subcommand Specific
(bits 7-4)**

Feature Previous Contents of SET FEATURES (15:8) field

Sector Count Current

TAG (bits 7-3) The TAG value is assigned to be different from all other queued commands. The value does not exceed the maximum queue depth specified by the Word 75 of the Identify Device information.

Sector Count Previous Contents of SET FEATURES LBA(7:0) field LBA (7:0).

Sector Number Current Contents of SET FEATURES LBA(27:24)

Cylinder Low Current Contents of SET FEATURES LBA(15:8)

Cylinder Low Previous

Cylinder High Current Contents of SET FEATURES LBA(23:16)

Cylinder High Previous

Device/Head

Input Parameters From The Device

Sector Number (HOB=0)

Sector Number (HOB=1)

Cylinder Low (HOB=0)

Cylinder Low (HOB=1)

Cylinder High (HOB=0)

Cylinder High (HOB=1)

11.16 RECEIVE FPDMA QUEUED (65h)

| Command Block Output Registers | | | | | | | | |
|--------------------------------|----------|---|---|---|---|---|---|---|
| Register | 7 | 6 | 5 | 4 | 3 | 2 | 1 | 0 |
| Data Low | - | - | - | - | - | - | - | - |
| Data High | - | - | - | - | - | - | - | - |
| Feature | Current | V | V | V | V | V | V | V |
| | Previous | - | - | - | - | - | - | - |
| Sector Count | Current | V | V | V | V | - | - | - |
| | Previous | V | V | - | - | - | - | - |
| Sector Number | Current | V | V | V | V | - | - | - |
| | Previous | - | - | - | - | - | - | - |
| Cylinder Low | Current | - | - | - | - | - | - | - |
| | Previous | - | - | - | - | - | - | - |
| Cylinder High | Current | - | - | - | - | - | - | - |
| | Previous | - | - | - | - | - | - | - |
| Device/Head | - | 1 | - | 0 | - | - | - | - |
| Command | 0 | 1 | 1 | 0 | 0 | 1 | 0 | 1 |

| Command Block Input Registers | | | | | | | | |
|-------------------------------|-----------------|---|---|---|---|---|---|---|
| Register | 7 | 6 | 5 | 4 | 3 | 2 | 1 | 0 |
| Data Low | - | - | - | - | - | - | - | - |
| Data High | - | - | - | - | - | - | - | - |
| Error | ...See Below... | | | | | | | |
| Sector Count | HOB=0 | - | - | - | - | - | - | - |
| | HOB=1 | - | - | - | - | - | - | - |
| Sector Number | HOB=0 | - | - | - | - | - | - | - |
| | HOB=1 | - | - | - | - | - | - | - |
| Cylinder Low | HOB=0 | - | - | - | - | - | - | - |
| | HOB=1 | - | - | - | - | - | - | - |
| Cylinder High | HOB=0 | - | - | - | - | - | - | - |
| | HOB=1 | - | - | - | - | - | - | - |
| Device/Head | - | - | - | - | - | - | - | - |
| Status | ...See Below... | | | | | | | |

| Error Register | | | | | | | |
|----------------|-----|---|-----|---|-----|-----|-----|
| 7 | 6 | 5 | 4 | 3 | 2 | 1 | 0 |
| CRC | UNC | 0 | IDN | 0 | ABT | T0N | AMN |
| V | V | 0 | V | 0 | V | 0 | 0 |

| Status Register | | | | | | | |
|-----------------|-----|----|-----|-----|-----|-----|-----|
| 7 | 6 | 5 | 4 | 3 | 2 | 1 | 0 |
| BSY | RDY | DF | DSC | DRQ | COR | IDX | ERR |
| 0 | V | 0 | - | 0 | - | - | V |

Table 131 RECEIVE FPDMA QUEUED Command (65h)

Table 132 defines the RECEIVE FPDMA QUEUED subcommands. See the referenced sections for additional information in this table.

| Subcommand | Description | Reference |
|------------|------------------|-------------------------------|
| 0h | Reserved | - |
| 1h | READ LOG DMA EXT | 11.16.1 READ LOG DMA EXT (1h) |
| 2h - Fh | Reserved | - |

Table 132 RECEIVE FPDMA QUEUED Subcommand Field

The output from the host to the device, the command acceptance outputs for this command, the normal outputs for this command and the error outputs for this command are subcommand specific. See 11.16.1 READ LOG DMA EXT (1h).

11.16.1 READ LOG DMA EXT (1h)

| Command Block Output Registers | | | | | | | | | |
|--------------------------------|----------|---|---|---|---|---|---|---|---|
| Register | 7 | 6 | 5 | 4 | 3 | 2 | 1 | 0 | |
| Data Low | - | - | - | - | - | - | - | - | |
| Data High | - | - | - | - | - | - | - | - | |
| Feature | Current | V | V | V | V | 0 | 0 | 0 | 1 |
| | Previous | - | - | - | - | - | - | - | - |
| Sector Count | Current | V | V | V | V | V | - | - | - |
| | Previous | - | - | - | - | - | - | - | - |
| Sector Number | Current | V | V | V | V | V | - | - | - |
| | Previous | - | - | - | - | - | - | - | - |
| Cylinder Low | Current | - | - | - | - | - | - | - | |
| | Previous | - | - | - | - | - | - | - | |
| Cylinder High | Current | - | - | - | - | - | - | - | |
| | Previous | - | - | - | - | - | - | - | |
| Device/Head | - | 1 | - | 0 | - | - | - | - | |
| Command | 0 | 1 | 1 | 0 | 0 | 0 | 1 | 1 | |

| Command Block Input Registers | | | | | | | | |
|-------------------------------|-----------------|---|---|---|---|---|---|---|
| Register | 7 | 6 | 5 | 4 | 3 | 2 | 1 | 0 |
| Data Low | - | - | - | - | - | - | - | - |
| Data High | - | - | - | - | - | - | - | - |
| Error | ...See Below... | | | | | | | |
| Sector Count | HOB=0 | - | - | - | - | - | - | - |
| | HOB=1 | - | - | - | - | - | - | - |
| Sector Number | HOB=0 | - | - | - | - | - | - | - |
| | HOB=1 | - | - | - | - | - | - | - |
| Cylinder Low | HOB=0 | - | - | - | - | - | - | - |
| | HOB=1 | - | - | - | - | - | - | - |
| Cylinder High | HOB=0 | - | - | - | - | - | - | - |
| | HOB=1 | - | - | - | - | - | - | - |
| Device/Head | - | - | - | - | - | - | - | - |
| Status | ...See Below... | | | | | | | |

| Error Register | | | | | | | |
|----------------|-----|---|-----|---|-----|-----|-----|
| 7 | 6 | 5 | 4 | 3 | 2 | 1 | 0 |
| CRC | UNC | 0 | IDN | 0 | ABT | T0N | AMN |
| V | V | 0 | V | 0 | V | 0 | 0 |

| Status Register | | | | | | | |
|-----------------|-----|----|-----|-----|-----|-----|-----|
| 7 | 6 | 5 | 4 | 3 | 2 | 1 | 0 |
| BSY | RDY | DF | DSC | DRQ | COR | IDX | ERR |
| 0 | V | 0 | - | 0 | - | - | V |

Table 133 READ LOG DMA EXT Subcommand (1h)

Normal Outputs

Upon successful completion of one or more outstanding commands, the device shall transmit a Set Device Bits FIS with the Interrupt bit set to one and one or more bits set to one in the ACT field corresponding to the bit position for each command TAG that has completed since the last status notification was transmitted.

Error Outputs

If the device has received a command that has not yet been acknowledged by clearing the BSY bit to zero and an error is encountered, the device shall transmit a Register Device to Host FIS.

Output Parameters To The Device

Feature Current

Contents of READ LOG DMA EXT Count(7:0) field

Subcommand (bits 4-0)

When bits (4:0) is 01h, Read Log DMA Ext Subcommand.

Subcommand Specific (bits 7-4)

Feature Previous

Contents of READ LOG DMA EXT Count(15:8) field

Sector Count Current

TAG (bits 7-3)

Sector Count Previous

Sector Number Current

Contents of READ LOG DMA EXT LBA(7:0) field

Sector Number Previous

Contents of READ LOG DMA EXT LBA(31:24) field

Cylinder Low Current

Contents of READ LOG DMA EXT LBA(15:8) field

Cylinder Low Previous

Contents of READ LOG DMA EXT LBA(39:32) field

Cylinder High Current

Contents of READ LOG DMA EXT LBA(23:16) field

**Cylinder High Previous
Device/Head**

Contents of READ LOG DMA EXT LBA(47:40) field

Input Parameters From The Device

Sector Number (HOB=0)

Sector Number (HOB=1)

Cylinder Low (HOB=0)

Cylinder Low (HOB=1)

Cylinder High (HOB=0)

Cylinder High (HOB=1)

11.17 SEND FPDMA QUEUED (64h)

| Command Block Output Registers | | | | | | | | |
|--------------------------------|----------|---|---|---|---|---|---|---|
| Register | 7 | 6 | 5 | 4 | 3 | 2 | 1 | 0 |
| Data Low | - | - | - | - | - | - | - | - |
| Data High | - | - | - | - | - | - | - | - |
| Feature | Current | V | V | V | V | V | V | V |
| | Previous | - | - | - | - | - | - | - |
| Sector Count | Current | V | V | V | V | - | - | - |
| | Previous | V | V | - | - | - | - | - |
| Sector Number | Current | V | V | V | V | - | - | - |
| | Previous | - | - | - | - | - | - | - |
| Cylinder Low | Current | - | - | - | - | - | - | - |
| | Previous | - | - | - | - | - | - | - |
| Cylinder High | Current | - | - | - | - | - | - | - |
| | Previous | - | - | - | - | - | - | - |
| Device/Head | - | 1 | - | 0 | - | - | - | - |
| Command | 0 | 1 | 1 | 0 | 0 | 1 | 0 | 0 |

| Command Block Input Registers | | | | | | | | |
|-------------------------------|-----------------|---|---|---|---|---|---|---|
| Register | 7 | 6 | 5 | 4 | 3 | 2 | 1 | 0 |
| Data Low | - | - | - | - | - | - | - | - |
| Data High | - | - | - | - | - | - | - | - |
| Error | ...See Below... | | | | | | | |
| Sector Count | HOB=0 | - | - | - | - | - | - | - |
| | HOB=1 | - | - | - | - | - | - | - |
| Sector Number | HOB=0 | - | - | - | - | - | - | - |
| | HOB=1 | - | - | - | - | - | - | - |
| Cylinder Low | HOB=0 | - | - | - | - | - | - | - |
| | HOB=1 | - | - | - | - | - | - | - |
| Cylinder High | HOB=0 | - | - | - | - | - | - | - |
| | HOB=1 | - | - | - | - | - | - | - |
| Device/Head | - | - | - | - | - | - | - | - |
| Status | ...See Below... | | | | | | | |

| Error Register | | | | | | | |
|----------------|-----|---|-----|---|-----|-----|-----|
| 7 | 6 | 5 | 4 | 3 | 2 | 1 | 0 |
| CRC | UNC | 0 | IDN | 0 | ABT | T0N | AMN |
| V | V | 0 | V | 0 | V | 0 | 0 |

| Status Register | | | | | | | |
|-----------------|-----|----|-----|-----|-----|-----|-----|
| 7 | 6 | 5 | 4 | 3 | 2 | 1 | 0 |
| BSY | RDY | DF | DSC | DRQ | COR | IDX | ERR |
| 0 | V | 0 | - | 0 | - | - | V |

Table 134 SEND FPDMA QUEUED command (64h)

Table 135 defines the SEND FPDMA QUEUED subcommands. See the referenced sections for additional information in this table.

| Subcommand | Description | Reference |
|------------|-------------------|--------------------------------|
| 0h – 1h | Reserved | - |
| 2h | WRITE LOG DMA EXT | 11.17.1 WRITE LOG DMA EXT (2h) |
| 3h – Fh | Reserved | - |

Table 135 SEND FPDMA QUEUED Subcommand Field

The output from the host to the device, the command acceptance outputs for this command, the normal outputs for this command and the error outputs for this command are subcommand specific.

11.17.1 WRITE LOG DMA EXT (2h)

| Command Block Output Registers | | | | | | | | |
|--------------------------------|----------|---|---|---|---|---|---|---|
| Register | 7 | 6 | 5 | 4 | 3 | 2 | 1 | 0 |
| Data Low | - | - | - | - | - | - | - | - |
| Data High | - | - | - | - | - | - | - | - |
| Feature | Current | V | V | V | V | 0 | 0 | 1 |
| | Previous | - | - | - | - | - | - | - |
| Sector Count | Current | V | V | V | V | V | - | - |
| | Previous | - | - | - | - | - | - | - |
| Sector Number | Current | V | V | V | V | V | - | - |
| | Previous | - | - | - | - | - | - | - |
| Cylinder Low | Current | - | - | - | - | - | - | - |
| | Previous | - | - | - | - | - | - | - |
| Cylinder High | Current | - | - | - | - | - | - | - |
| | Previous | - | - | - | - | - | - | - |
| Device/Head | - | 1 | - | 0 | - | - | - | - |
| Command | 0 | 1 | 1 | 0 | 0 | 1 | 0 | 0 |

| Command Block Input Registers | | | | | | | | |
|-------------------------------|-----------------|---|---|---|---|---|---|---|
| Register | 7 | 6 | 5 | 4 | 3 | 2 | 1 | 0 |
| Data Low | - | - | - | - | - | - | - | - |
| Data High | - | - | - | - | - | - | - | - |
| Error | ...See Below... | | | | | | | |
| Sector Count | HOB=0 | - | - | - | - | - | - | - |
| | HOB=1 | - | - | - | - | - | - | - |
| Sector Number | HOB=0 | - | - | - | - | - | - | - |
| | HOB=1 | - | - | - | - | - | - | - |
| Cylinder Low | HOB=0 | - | - | - | - | - | - | - |
| | HOB=1 | - | - | - | - | - | - | - |
| Cylinder High | HOB=0 | - | - | - | - | - | - | - |
| | HOB=1 | - | - | - | - | - | - | - |
| Device/Head | - | - | - | - | - | - | - | - |
| Status | ...See Below... | | | | | | | |

| Error Register | | | | | | | |
|----------------|-----|---|-----|---|-----|-----|-----|
| 7 | 6 | 5 | 4 | 3 | 2 | 1 | 0 |
| CRC | UNC | 0 | IDN | 0 | ABT | T0N | AMN |
| V | V | 0 | V | 0 | V | 0 | 0 |

| Status Register | | | | | | | |
|-----------------|-----|----|-----|-----|-----|-----|-----|
| 7 | 6 | 5 | 4 | 3 | 2 | 1 | 0 |
| BSY | RDY | DF | DSC | DRQ | COR | IDX | ERR |
| 0 | V | 0 | - | 0 | - | - | V |

Table 136 WRITE LOG DMA EXT Subcommand (2h)

Normal Outputs

Upon successful completion of one or more outstanding commands, the device shall transmit a Set Device Bits FIS with one or more bits set to one in the ACT field corresponding to the bit position for each command TAG that has completed since the last status notification was transmitted.

Error Outputs

If the device has received a command that has not yet been acknowledged by clearing the BSY bit to zero and an error is encountered, the device shall transmit a Register Device to Host FIS.

Output Parameters To The Device

| | |
|---------------------------------------|--|
| Feature Current | Contents of WRITE LOG DMA EXT Count(7:0) field |
| Subcommand (bits 4-0) | When bits (4:0) is 02h, Read Log DMA Ext Subcommand. |
| Subcommand Specific (bits 7-4) | |
| Feature Previous | Contents of WRITE LOG DMA EXT Count(15:8) field |
| Sector Count Current | |
| TAG (bits 7-3) | |
| Sector Count Previous | |
| Sector Number Current | Contents of WRITE LOG DMA EXT LBA(7:0) field |
| Sector Number Previous | Contents of WRITE LOG DMA EXT LBA(31:24) field |
| Cylinder Low Current | Contents of WRITE LOG DMA EXT LBA(15:8) field |
| Cylinder Low Previous | Contents of WRITE LOG DMA EXT LBA(39:32) field |

| | |
|-------------------------------|--|
| Cylinder High Current | Contents of WRITE LOG DMA EXT LBA(23:16) field |
| Cylinder High Previous | Contents of WRITE LOG DMA EXT LBA(47:40) field |
| Device/Head | |

Input Parameters From The Device

Sector Number (HOB=0)

Sector Number (HOB=1)

Cylinder Low (HOB=0)

Cylinder Low (HOB=1)

Cylinder High (HOB=0)

Cylinder High (HOB=1)

11.18 Read Buffer (E4h)

| Command Block Output Registers | | | | | | | | |
|--------------------------------|---|---|---|---|---|---|---|---|
| Register | 7 | 6 | 5 | 4 | 3 | 2 | 1 | 0 |
| Data | - | - | - | - | - | - | - | - |
| Feature | - | - | - | - | - | - | - | - |
| Sector Count | - | - | - | - | - | - | - | - |
| Sector Number | - | - | - | - | - | - | - | - |
| Cylinder Low | - | - | - | - | - | - | - | - |
| Cylinder High | - | - | - | - | - | - | - | - |
| Device/Head | 1 | - | 1 | D | - | - | - | - |
| Command | 1 | 1 | 1 | 0 | 0 | 1 | 0 | 0 |

| Command Block Input Registers | | | | | | | | |
|-------------------------------|-----------------|---|---|---|---|---|---|---|
| Register | 7 | 6 | 5 | 4 | 3 | 2 | 1 | 0 |
| Data | - | - | - | - | - | - | - | - |
| Error | ...See Below... | | | | | | | |
| Sector Count | - | - | - | - | - | - | - | - |
| Sector Number | - | - | - | - | - | - | - | - |
| Cylinder Low | - | - | - | - | - | - | - | - |
| Cylinder High | - | - | - | - | - | - | - | - |
| Device/Head | - | - | - | - | - | - | - | - |
| Status | ...See Below... | | | | | | | |

| Error Register | | | | | | | |
|----------------|-----|---|-----|---|-----|-----|-----|
| 7 | 6 | 5 | 4 | 3 | 2 | 1 | 0 |
| CRC | UNC | 0 | IDN | 0 | ABT | T0N | AMN |
| 0 | 0 | 0 | 0 | 0 | V | 0 | 0 |

| Status Register | | | | | | | |
|-----------------|-----|----|-----|-----|-----|-----|-----|
| 7 | 6 | 5 | 4 | 3 | 2 | 1 | 0 |
| BSY | RDY | DF | DSC | DRQ | COR | IDX | ERR |
| 0 | V | 0 | - | - | 0 | - | V |

Table 137 Read Buffer Command (E4h)

The Read Buffer command transfers a sector of data from the sector buffer of device to the host.

The sector is transferred through the Data Register 16 bits at a time.

The sector transferred will be from the same part of the buffer written to by the last Write Buffer command. The contents of the sector may be different if any reads or writes have occurred since the Write Buffer command was issued.

11.19 Read Buffer DMA (E9h)

| Command Block Output Registers | | | | | | | | |
|--------------------------------|---|---|---|---|---|---|---|---|
| Register | 7 | 6 | 5 | 4 | 3 | 2 | 1 | 0 |
| Data | - | - | - | - | - | - | - | - |
| Feature | - | - | - | - | - | - | - | - |
| Sector Count | - | - | - | - | - | - | - | - |
| Sector Number | - | - | - | - | - | - | - | - |
| Cylinder Low | - | - | - | - | - | - | - | - |
| Cylinder High | - | - | - | - | - | - | - | - |
| Device/Head | 1 | - | 1 | D | - | - | - | - |
| Command | 1 | 1 | 1 | 0 | 1 | 0 | 0 | 1 |

| Command Block Input Registers | | | | | | | | |
|-------------------------------|-----------------|---|---|---|---|---|---|---|
| Register | 7 | 6 | 5 | 4 | 3 | 2 | 1 | 0 |
| Data | - | - | - | - | - | - | - | - |
| Error | ...See Below... | | | | | | | |
| Sector Count | - | - | - | - | - | - | - | - |
| Sector Number | - | - | - | - | - | - | - | - |
| Cylinder Low | - | - | - | - | - | - | - | - |
| Cylinder High | - | - | - | - | - | - | - | - |
| Device/Head | - | - | - | - | - | - | - | - |
| Status | ...See Below... | | | | | | | |

| Error Register | | | | | | | |
|----------------|-----|---|-----|---|-----|-----|-----|
| 7 | 6 | 5 | 4 | 3 | 2 | 1 | 0 |
| CRC | UNC | 0 | IDN | 0 | ABT | T0N | AMN |
| 0 | 0 | 0 | 0 | 0 | V | 0 | 0 |

| Status Register | | | | | | | |
|-----------------|-----|----|-----|-----|-----|-----|-----|
| 7 | 6 | 5 | 4 | 3 | 2 | 1 | 0 |
| BSY | RDY | DF | DSC | DRQ | COR | IDX | ERR |
| 0 | V | 0 | - | - | 0 | - | V |

Table 138 Read Buffer DMA Command (E9h)

The Read Buffer DMA command transfers a sector of data from the sector buffer of device to the host.

The sector is transferred through the Data Register 16 bits at a time.

The sector transferred will be from the same part of the buffer written to by the last Write Buffer command. The contents of the sector may be different if any reads or writes have occurred since the Write Buffer command was issued.

11.20 Read DMA(C8h/C9h)

| Command Block Output Registers | | | | | | | | |
|--------------------------------|---|---|---|---|---|---|---|---|
| Register | 7 | 6 | 5 | 4 | 3 | 2 | 1 | 0 |
| Data | - | - | - | - | - | - | - | - |
| Feature | - | - | - | - | - | - | - | - |
| Sector Count | V | V | V | V | V | V | V | V |
| Sector Number | V | V | V | V | V | V | V | V |
| Cylinder Low | V | V | V | V | V | V | V | V |
| Cylinder High | V | V | V | V | V | V | V | V |
| Device/Head | 1 | L | 1 | D | H | H | H | H |
| Command | 1 | 1 | 0 | 0 | 1 | 0 | 0 | R |

| Command Block Input Registers | | | | | | | | |
|-------------------------------|-----------------|---|---|---|---|---|---|---|
| Register | 7 | 6 | 5 | 4 | 3 | 2 | 1 | 0 |
| Data | - | - | - | - | - | - | - | - |
| Error | ...See Below... | | | | | | | |
| Sector Count | V | V | V | V | V | V | V | V |
| Sector Number | V | V | V | V | V | V | V | V |
| Cylinder Low | V | V | V | V | V | V | V | V |
| Cylinder High | V | V | V | V | V | V | V | V |
| Device/Head | - | - | - | - | H | H | H | H |
| Status | ...See Below... | | | | | | | |

| Error Register | | | | | | | |
|----------------|-----|---|-----|---|-----|-----|-----|
| 7 | 6 | 5 | 4 | 3 | 2 | 1 | 0 |
| CRC | UNC | 0 | IDN | 0 | ABT | TON | AMN |
| V | V | 0 | V | 0 | V | 0 | 0 |

| Status Register | | | | | | | |
|-----------------|-----|----|-----|-----|-----|-----|-----|
| 7 | 6 | 5 | 4 | 3 | 2 | 1 | 0 |
| BSY | RDY | DF | DSC | DRQ | COR | IDX | ERR |
| 0 | V | 0 | V | - | 0 | - | V |

Table 139 Read DMA Command (C8h/C9h)

The Read DMA command reads one or more sectors of data from disk media, then transfers the data from the device to the host.

The sectors are transferred through the Data Register 16 bits at a time.

The host initializes a slave-DMA channel prior to issuing the command. The data transfers are qualified by DMARQ and are performed by the slave-DMA channel. The device issues only one interrupt per command to indicate that data transfer has terminated and status is available.

If an uncorrectable error occurs, the read will be terminated at the failing sector.

Output Parameters To The Device

| | |
|--------------------------|--|
| Sector Count | The number of continuous sectors to be transferred. If zero is specified, then 256 sectors will be transferred. |
| Sector Number | The sector number of the first sector to be transferred. (L=0) In LBA mode, this register specifies LBA address bits 0-7 to be transferred. (L=1) |
| Cylinder High/Low | The cylinder number of the first sector to be transferred. (L=0) In LBA mode, this register specifies LBA address bits 8-15 (Low) 16-23 (High) to be transferred. (L=1) |
| H | The head number of the first sector to be transferred. (L=0) In LBA mode, this register specifies LBA bits 24-27 to be transferred. (L=1) |
| R | The retry bit, but this bit is ignored. |

Input Parameters From The Device

| | |
|--------------------------|---|
| Sector Count | The number of requested sectors not transferred. This will be zero, unless an unrecoverable error occurs. |
| Sector Number | The sector number of the last transferred sector. (L=0) In LBA mode, this register contains current LBA bits 0-7. (L=1) |
| Cylinder High/Low | The cylinder number of the last transferred sector. (L=0) In LBA mode, this register contains current LBA bits 8-15 (Low), 16-23 (High). (L=1) |
| H | The head number of the sector to be transferred. (L=0) In LBA mode, this register contains current LBA bits 24-27. (L=1) |

11.21 Read DMA Ext (25h)

| Command Block Output Registers | | | | | | | | |
|--------------------------------|----------|---|---|---|---|---|---|---|
| Register | 7 | 6 | 5 | 4 | 3 | 2 | 1 | 0 |
| Data Low | - | - | - | - | - | - | - | - |
| Data High | - | - | - | - | - | - | - | - |
| Feature | Current | - | - | - | - | - | - | - |
| | Previous | - | - | - | - | - | - | - |
| Sector Count | Current | V | V | V | V | V | V | V |
| | Previous | V | V | V | V | V | V | V |
| Sector Number | Current | V | V | V | V | V | V | V |
| | Previous | V | V | V | V | V | V | V |
| Cylinder Low | Current | V | V | V | V | V | V | V |
| | Previous | V | V | V | V | V | V | V |
| Cylinder High | Current | V | V | V | V | V | V | V |
| | Previous | V | V | V | V | V | V | V |
| Device/Head | 1 | 1 | 1 | D | - | - | - | - |
| Command | 0 | 0 | 1 | 0 | 0 | 1 | 0 | 1 |

| Command Block Input Registers | | | | | | | | |
|-------------------------------|-----------------|---|---|---|---|---|---|---|
| Register | 7 | 6 | 5 | 4 | 3 | 2 | 1 | 0 |
| Data Low | - | - | - | - | - | - | - | - |
| Data High | - | - | - | - | - | - | - | - |
| Error | ...See Below... | | | | | | | |
| Sector Count | HOB=0 | - | - | - | - | - | - | - |
| | HOB=1 | - | - | - | - | - | - | - |
| Sector Number | HOB=0 | V | V | V | V | V | V | V |
| | HOB=1 | V | V | V | V | V | V | V |
| Cylinder Low | HOB=0 | V | V | V | V | V | V | V |
| | HOB=1 | V | V | V | V | V | V | V |
| Cylinder High | HOB=0 | V | V | V | V | V | V | V |
| | HOB=1 | V | V | V | V | V | V | V |
| Device/Head | - | - | - | - | - | - | - | - |
| Status | ...See Below... | | | | | | | |

| Error Register | | | | | | | |
|----------------|-----|---|-----|---|-----|-----|-----|
| 7 | 6 | 5 | 4 | 3 | 2 | 1 | 0 |
| CRC | UNC | 0 | IDN | 0 | ABT | TON | AMN |
| V | Vs | 0 | V | 0 | V | 0 | 0 |

| Status Register | | | | | | | |
|-----------------|-----|----|-----|-----|-----|-----|-----|
| 7 | 6 | 5 | 4 | 3 | 2 | 1 | 0 |
| BSY | RDY | DF | DSC | DRQ | COR | IDX | ERR |
| 0 | V | 0 | V | - | 0 | - | V |

Table 140 Read DMA Ext Command (25h)

The Read DMA command reads one or more sectors of data from disk media, and then transfers the data from the device to the host.

The sectors are transferred through the Data Register 16 bits at a time.

The host initializes a slave-DMA channel prior to issuing the command. The data transfers are qualified by DMARQ and are performed by the slave-DMA channel. The device issues only one interrupt per command to indicate that data transfer has terminated and status is available.

If an uncorrectable error occurs, the read will be terminated at the failing sector.

Output Parameters To The Device

| | |
|-------------------------------|---|
| Sector Count Current | The number of sectors to be transferred low order, bits (7:0). |
| Sector Count Previous | The number of sectors to be transferred high order, bits (15:8). If 0000h in the Sector Count register is specified, then 65,536 sectors will be transferred. |
| Sector Number Current | LBA (7:0) |
| Sector Number Previous | LBA (31:24) |
| Cylinder Low Current | LBA (15:8) |
| Cylinder Low Previous | LBA (39:32) |
| Cylinder High Current | LBA (23:16) |
| Cylinder High Previous | LBA (47:40) |

Input Parameters From The Device

| | |
|------------------------------|--|
| Sector Number (HOB=0) | LBA (7:0) of the address of the first unrecoverable error. |
| Sector Number (HOB=1) | LBA (31:24) of the address of the first unrecoverable error. |
| Cylinder Low (HOB=0) | LBA (15:8) of the address of the first unrecoverable error. |
| Cylinder Low (HOB=1) | LBA (39:32) of the address of the first unrecoverable error. |
| Cylinder High (HOB=0) | LBA (23:16) of the address of the first unrecoverable error. |
| Cylinder High (HOB=1) | LBA (47:40) of the address of the first unrecoverable error. |

11.22 Read FPDMA Queued (60h)

| Command Block Output Registers | | | | | | | | |
|--------------------------------|----------|---|---|---|---|---|---|---|
| Register | 7 | 6 | 5 | 4 | 3 | 2 | 1 | 0 |
| Data Low | - | - | - | - | - | - | - | - |
| Data High | - | - | - | - | - | - | - | - |
| Feature | Current | V | V | V | V | V | V | V |
| | Previous | V | V | V | V | V | V | V |
| Sector Count | Current | V | V | V | V | - | - | - |
| | Previous | - | - | - | - | - | - | - |
| Sector Number | Current | V | V | V | V | V | V | V |
| | Previous | V | V | V | V | V | V | V |
| Cylinder Low | Current | V | V | V | V | V | V | V |
| | Previous | V | V | V | V | V | V | V |
| Cylinder High | Current | V | V | V | V | V | V | V |
| | Previous | V | V | V | V | V | V | V |
| Device/Head | V | 1 | 0 | 0 | - | - | - | - |
| Command | 0 | 1 | 1 | 0 | 0 | 0 | 0 | 0 |

| Command Block Input Registers | | | | | | | | |
|-------------------------------|-----------------|---|---|---|---|---|---|---|
| Register | 7 | 6 | 5 | 4 | 3 | 2 | 1 | 0 |
| Data Low | - | - | - | - | - | - | - | - |
| Data High | - | - | - | - | - | - | - | - |
| Error | ...See Below... | | | | | | | |
| Sector Count | HOB=0 | - | - | - | - | - | - | - |
| | HOB=1 | - | - | - | - | - | - | - |
| Sector Number | HOB=0 | V | V | V | V | V | V | V |
| | HOB=1 | V | V | V | V | V | V | V |
| Cylinder Low | HOB=0 | V | V | V | V | V | V | V |
| | HOB=1 | V | V | V | V | V | V | V |
| Cylinder High | HOB=0 | V | V | V | V | V | V | V |
| | HOB=1 | V | V | V | V | V | V | V |
| Device/Head | - | - | - | - | - | - | - | - |
| Status | ...See Below... | | | | | | | |

| Error Register | | | | | | | |
|----------------|-----|---|-----|---|-----|-----|-----|
| 7 | 6 | 5 | 4 | 3 | 2 | 1 | 0 |
| CRC | UNC | 0 | IDN | 0 | ABT | T0N | AMN |
| V | Vs | 0 | V | 0 | V | 0 | 0 |

| Status Register | | | | | | | |
|-----------------|-----|----|-----|-----|-----|-----|-----|
| 7 | 6 | 5 | 4 | 3 | 2 | 1 | 0 |
| BSY | RDY | DF | DSC | DRQ | COR | IDX | ERR |
| 0 | V | 0 | V | - | 0 | - | V |

Table 141 Read FPDMA Queued Command (60h)

The Read FPDMA command reads one or more sectors of data from disk media, and then transfers the data from the device to the host.

If an uncorrectable error occurs, the read will be terminated at the failing sector.

Output Parameters To The Device

Feature Current The number of sectors to be transferred low order, bits (7:0).

Feature Previous The number of sectors to be transferred high order, bits (15:8).

Sector Count Current

TAG (bits 7-3)

The TAG value shall be assigned to be different from all other queued commands. The value shall not exceed the maximum queue depth specified by the Word 75 of the Identify Device information.

RARC (bits 0)

If the Rebuild Assist feature is not supported, then the RARC bit shall be ignored. If the Rebuild Assist feature is supported and is disabled, then the RARC bit shall be ignored.

If the Rebuild Assist feature is supported and enabled, then the RARC bit specifies that read operations shall be processed as defined in 9.17.5 Rebuild Assist Log (15h).

Sector Count Previous

PRIO (bits 7-6)

The Priority (PRIO) value shall be assigned by the host based on the priority of the command issued. The device makes a best effort to complete High priority requests in a more timely fashion than Normal and isochronous priority requests. The device tries to complete isochronous requests prior to its associated deadline. The Priority values are defined as follows:

- 00b Normal priority
- 01b Isochronous – deadline dependent priority
- 10b High priority

Sector Number Current

LBA (7:0)

Sector Number Previous

LBA (31:24)

Cylinder Low Current

LBA (15:8)

Cylinder Low Previous

LBA (39:32)

Cylinder High Current

LBA (23:16)

Cylinder High Previous

LBA (47:40)

ZCICC

The Isochronous Command Completion (ICC) field is valid when PRIO is set to a value of 01b. It is assigned by the host based on the intended deadline associated with the command issued. When a deadline has expired, the device continues to complete the command as soon as possible. The host can modify this behavior if the device supports the NCQ NON-DATA command (see 11.15 NCQ NON-DATA (63h)) and supports the Deadline Handling subcommand (see 11.15.2 Deadline Handling Subcommand (1h)). This subcommand allows the host to set whether the device aborts commands that have exceeded the time set in ICC.

There are several parameters encoded in the ICC field: Fine or Coarse timing, Interval and the Max Time. The Interval indicates the time units of the Time Limit parameter.

If ICC Bit 7 cleared to zero, then the time interval is fine-grained.

- Interval = 10msec
- Time Limit = (ICC[6:0] + 1) * 10 msec

If ICC Bit 7 is set to one (coarse encoding), then the time interval is coarse grained.

- Interval = 0.5 sec
- Time Limit = (ICC[6:0] + 1) * 0.5 sec

Device/Head

FUA (bit 7)

When the FUA bit is set to 1, the requested data is always retrieved from the media regardless of whether the data are held in the sector buffer or not.

When the FUA bit is set to 0, the data may be retrieved from the media or from the cached data left by previously processed Read or Write commands.

Input Parameters From The Device

Sector Number (HOB=0)

LBA (7:0) of the address of the first unrecoverable error.

Sector Number (HOB=1)

LBA (31:24) of the address of the first unrecoverable error.

Cylinder Low (HOB=0)

LBA (15:8) of the address of the first unrecoverable error.

Cylinder Low (HOB=1)

LBA (39:32) of the address of the first unrecoverable error.

Cylinder High (HOB=0)

LBA (23:16) of the address of the first unrecoverable error.

Cylinder High (HOB=1)

LBA (47:40) of the address of the first unrecoverable error.

11.23 Read Log Ext (2Fh)

| Command Block Output Registers | | | | | | | | | |
|--------------------------------|----------|---|---|---|---|---|---|---|---|
| Register | | 7 | 6 | 5 | 4 | 3 | 2 | 1 | 0 |
| Data Low | | - | - | - | - | - | - | - | - |
| Data High | | - | - | - | - | - | - | - | - |
| Feature | Current | V | V | V | V | V | V | V | V |
| | Previous | V | V | V | V | V | V | V | V |
| Sector Count | Current | V | V | V | V | V | V | V | V |
| | Previous | V | V | V | V | V | V | V | V |
| Sector Number | Current | V | V | V | V | V | V | V | V |
| | Previous | - | - | - | - | - | - | - | - |
| Cylinder Low | Current | V | V | V | V | V | V | V | V |
| | Previous | V | V | V | V | V | V | V | V |
| Cylinder High | Current | - | - | - | - | - | - | - | - |
| | Previous | - | - | - | - | - | - | - | - |
| Device/Head | | 1 | - | 1 | D | - | - | - | - |
| Command | | 0 | 0 | 1 | 0 | 1 | 1 | 1 | 1 |

| Command Block Input Registers | | | | | | | | | | |
|-------------------------------|-------|-----------------|---|---|---|---|---|---|---|--|
| Register | | 7 | 6 | 5 | 4 | 3 | 2 | 1 | 0 | |
| Data Low | | - | - | - | - | - | - | - | - | |
| Data High | | - | - | - | - | - | - | - | - | |
| Error | | ...See Below... | | | | | | | | |
| Sector Count | HOB=0 | - | - | - | - | - | - | - | - | |
| | HOB=1 | - | - | - | - | - | - | - | - | |
| Sector Number | HOB=0 | - | - | - | - | - | - | - | - | |
| | HOB=1 | - | - | - | - | - | - | - | - | |
| Cylinder Low | HOB=0 | - | - | - | - | - | - | - | - | |
| | HOB=1 | - | - | - | - | - | - | - | - | |
| Cylinder High | HOB=0 | - | - | - | - | - | - | - | - | |
| | HOB=1 | - | - | - | - | - | - | - | - | |
| Device/Head | | - | - | - | - | - | - | - | - | |
| Status | | ...See Below... | | | | | | | | |

| Error Register | | | | | | | |
|----------------|-----|---|-----|---|-----|-----|-----|
| 7 | 6 | 5 | 4 | 3 | 2 | 1 | 0 |
| CRC | UNC | 0 | IDN | 0 | ABT | T0N | AMN |
| 0 | V | 0 | V | 0 | V | 0 | 0 |

| Status Register | | | | | | | |
|-----------------|-----|----|-----|-----|-----|-----|-----|
| 7 | 6 | 5 | 4 | 3 | 2 | 1 | 0 |
| BSY | RDY | DF | DSC | DRQ | COR | IDX | ERR |
| 0 | V | 0 | V | - | 0 | - | V |

Table 142 Read Log Ext Command (2Fh)

This command returns the specified log to the host. The device shall interrupt for each DRQ block transferred.

Output Parameters To The Device

| | |
|------------------------------|--|
| Feature | Log Address Specific |
| Sector Count Current | The number of sectors to be read from the specified log low order, bits (7:0). The log transferred by the drive shall start at the sector in the specified log at the specified offset, regardless of the sector count requested. |
| Sector Count Previous | The number of sectors to be read from the specified log high orders, bits (15:8). |
| Sector Number Current | The log to be returned as described in Table 143. |
| Cylinder Low Current | The first sector of the log to be read low order, bits (7:0). |
| Cylinder Low Previous | The first sector of the log to be read high order, bits (15:8). |

| Log address | Content | Feature set | Type |
|-------------|--|--------------------------|------------|
| 00h | Log directory | N/A | Read Only |
| 03h | Extended Comprehensive SMART error log | SMART error logging | Read Only |
| 04h | Device Statistics | N/A | Read Only |
| 06h | SMART self-test log | SMART self-test | See Note |
| 07h | Extended SMART self-test log | SMART self-test | Read Only |
| 08h | Power Conditions log | Extended Power Condition | Read Only |
| 10h | Command Error | Native Command Queuing | Read Only |
| 11h | Phy Event Counters | Serial ATA | Read Only |
| 12h | NCQ NON-DATA log | NCQ NON-DATA | Read Only |
| 21h | Write Stream Error log | Streaming | Read Only |
| 22h | Read Stream Error log | Streaming | Read Only |
| 2Fh | Sector Configuration log | N/A | Read Only |
| 30h | Identify Device Data log | N/A | Read Only |
| 80h-9Fh | Host vendor specific | SMART | Read/Write |

Note: If log address 06h is accessed using the Read Log Ext or Write Log Ext commands, command abort shall be returned.

Note: Please see 9.17.3 about Phy Event Counters.

Note: Please see 9.17.4 about NCQ NON-DATA (63h).

Table 143 Log Address Definition

| Log Address | Description |
|-------------|----------------------------------|
| 00h - 0Fh | As defined in the ACS-2 standard |
| 10h | NCQ Queued Error log |
| 11h | Phy Event Counters log |
| 12h | NCQ NON-DATA log |
| 13h | Reserved |
| 14h | Reserved |
| 15h | Rebuild Assist log |
| 16h - 17h | Reserved |
| 18h - FFh | As defined in the ACS-2 standard |

Table 144 Log Address Definition for Serial ATA

The Extended SMART self-test log sector shall support 48-bit and 28-bit addressing. All 28-bit entries contained in the SMART self-test log sector shall also be included in the Comprehensive SMART self-test log sector with the 48-bit entries.

If the feature set associated with the log specified in the Sector Number register is not supported or enabled, or if the values in the Sector Count, Sector Number or Cylinder Low registers are invalid, the device shall return command aborted.

11.23.1 General Purpose Log Directory

Table 145 defines the 512 bytes that make up the General Purpose Log Directory.

| Description | Bytes | Offset |
|--|-------|--------|
| General Purpose Logging Version | 2 | 00h |
| Number of sectors in the log at log address 01h (7:0) | 1 | 02h |
| Number of sectors in the log at log address 01h (15:8) | 1 | 03h |
| Number of sectors in the log at log address 02h (7:0) | 1 | 04h |
| Number of sectors in the log at log address 02h (15:8) | 1 | 05h |
| ... | | |
| Number of sectors in the log at log address 20h (7:0) | 1 | 40h |
| Number of sectors in the log at log address 20h (15:8) | 1 | 41h |
| Number of sectors in the log at log address 21h (7:0) | 1 | 42h |
| Number of sectors in the log at log address 21h (15:8) | 1 | 43h |
| Number of sectors in the log at log address 22h (7:0) | 1 | 44h |
| Number of sectors in the log at log address 22h (15:8) | 1 | 45h |
| ... | | |
| Number of sectors in the log at log address 80h (7:0) | 1 | 100h |
| Number of sectors in the log at log address 80h (15:8) | 1 | 101h |
| ... | | |
| Number of sectors in the log at log address FFh (7:0) | 1 | 1FEh |
| Number of sectors in the log at log address FFh (15:8) | 1 | 1FFh |
| | 512 | |

Table 145 General Purpose Log Directory

The value of the General Purpose Logging Version word shall be 0001h. A value of 0000h indicates that there is no General Purpose Log Directory.

The logs at log addresses 80-9Fh shall each be defined as 16 sectors long.

Table 145 defines the 512 bytes that make up the General Purpose Log Directory for Serial ATA.

| Byte | Log | Value |
|------------|-----|---|
| 000h..01Fh | | As defined in the ACS-2 standard |
| 020h | 10h | 1 if Native Command Queuing is supported, 0 if Native Command Queuing is not supported |
| 021h | 10h | 0 |
| 022h | 11 | 1 if Phy Event Counters are supported 0 if Phy Event Counters are not supported |
| 023h | 11h | 0 |
| 024h | 12h | 1 if NCQ NON-DATA is supported 0 if NCQ NON-DATA is not supported |
| 025h | 12h | 0 |
| 026h | | Reserved |
| 027h | | Reserved |
| 028h | | Reserved |
| 029h | | Reserved |
| 02Ah | 15h | 1 if Rebuild Assist log is supported 0 if Rebuild Assist log is not supported |
| 02Bh | 15h | 0 |
| 02Ch..2Fh | | Reserved |
| 030h..1FFh | | As defined in the ACS-2 standard |

Table 146 General Purpose Log Directory for Serial ATA

11.23.2 Extended Comprehensive SMART Error Log

Table 147 defines the format of each of the sectors that comprise the Extended Comprehensive SMART error log. Error log data structure shall not include errors attributed to the receipt of faulty commands such as command codes not implemented by the device or requests with invalid parameters or in valid addresses.

| Description | Bytes | Offset |
|------------------------------|-------|--------|
| SMART error log version | 1 | 00h |
| Reserved | 1 | 01h |
| Error log index (7:0) | 1 | 02h |
| Error log index (15:8) | 1 | 03h |
| 1st error log data structure | 124 | 04h |
| 2nd error log data structure | 124 | 80h |
| 3rd error log data structure | 124 | FCh |
| 4th error log data structure | 124 | 178h |
| Device error count | 2 | 1F4h |
| Reserved | 9 | 1F6h |
| Data structure checksum | 1 | 1FFh |
| | 512 | |

Table 147 Extended Comprehensive SMART Error Log

11.23.2.1 Error Log Version

The value of this version shall be 01h.

11.23.2.2 Error Log Index

This indicates the error log data structure representing the most recent error. If there have been no error log entries, it is cleared to 0. Valid values for the error log index are 0 to 4.

11.23.2.3 Extended Error Log Data Structure

An error log data structure shall be presented for each of the last four errors reported by the device. These error log data structure entries are viewed as a circular buffer. The fifth error shall create an error log structure that replaces the first error log data structure. The next error after that shall create an error log data structure that replaces the second error log structure, etc. Unused error log data structures shall be filled with zeros.

Data format of each error log structure is shown below.

| Description | Bytes | Offset |
|----------------------------|-------|--------|
| 1st command data structure | 18 | 00h |
| 2nd command data structure | 18 | 12h |
| 3rd command data structure | 18 | 24h |
| 4th command data structure | 18 | 36h |
| 5th command data structure | 18 | 48h |
| Error data structure | 34 | 5Ah |
| | 124 | |

Table 148 Extended Error Log Data Structure

Command data structure: Data format of each command data structure is shown below.

| Description | Bytes | Offset |
|--|-------|--------|
| Device Control register | 1 | 00h |
| Features register (7:0) (see Note) | 1 | 01h |
| Features register (15:8) | 1 | 02h |
| Sector count register (7:0) | 1 | 03h |
| Sector count register (15:8) | 1 | 04h |
| Sector number register (7:0) | 1 | 05h |
| Sector number register (15:8) | 1 | 06h |
| Cylinder Low register (7:0) | 1 | 07h |
| Cylinder Low register (15:8) | 1 | 08h |
| Cylinder High register (7:0) | 1 | 09h |
| Cylinder High register (15:8) | 1 | 0Ah |
| Device/Head register | 1 | 0Bh |
| Command register | 1 | 0Ch |
| Reserved | 1 | 0Dh |
| Timestamp (milliseconds from Power-on) | 4 | 0Eh |
| | 18 | |

Note: bits (7:0) refer to the most recently written contents of the register. Bits (15:8) refer to the contents of the register prior to the most recent write to the register.

Table 149 Command Data Structure

Error data structure: Data format of error data structure is shown below.

| Description | Bytes | Offset |
|---|-------|--------|
| Reserved | 1 | 00h |
| Error register | 1 | 01h |
| Sector count register (7:0) (see Note) | 1 | 02h |
| Sector count register (15:8) (see Note) | 1 | 03h |
| Sector number register (7:0) | 1 | 04h |
| Sector number register (15:8) | 1 | 05h |
| Cylinder Low register (7:0) | 1 | 06h |
| Cylinder Low register (15:8) | 1 | 07h |
| Cylinder High register (7:0) | 1 | 08h |
| Cylinder High register (15:8) | 1 | 09h |
| Device/Head register | 1 | 0Ah |
| Status register | 1 | 0Bh |
| Extended error data (vendor specific) | 19 | 0Ch |
| State | 1 | 1Fh |
| Life timestamp (hours) | 2 | 20h |
| | 34 | |

Note: bits (7:0) refer to the contents if the register is read with bit 7 of the Device Control register cleared to zero. Bits (15:8) refer to the contents if the register is read with bit 7 of the Device Control register set to one.

Table 150 Error Data Structure

State shall contain a value indicating the state of the device when the command was issued to the device or the reset occurred as described below.

| Value | State |
|----------------|---|
| x0h | Unknown |
| x1h | Sleep |
| x2h | Standby (If the EPC feature set is enabled, Standby is standby_y or standby_z) |
| x3h | Active/Idle (If the EPC feature set is enabled, Active/Idle is idle_a or idle_b or idle_c) |
| x4h | SMART Off-line or Self-test |
| x5h-xAh | Reserved |
| xBh-xFh | Vendor specific |

Note: The value of x is vendor specific.

11.23.2.4 Device Error Count

This field shall contain the total number of errors attributable to the device that have been reported by the device during the life of the device. This count shall not include errors attributed to the receipt of faulty commands such as commands codes not implemented by the device or requests with invalid parameters or invalid addresses. If the maximum value for this field is reached the count shall remain at the maximum value when additional errors are encountered and logged.

11.23.3 Device Statistics Log

The Device Statistics log contains selected statistics about the device.

The number of log pages may be greater than one.

See Table 93 for a list of defined log pages. Each supported log page consists of a header field that may be followed by defined statistics fields. If the Revision Number field in the log page header is 0000h, then that log page is not supported. All log page data following the last defined statistic for that log page is reserved.

If an unsupported log page is requested, then 512 bytes of all zeros are returned for that log page.

| Description | Log page |
|---|----------|
| List of supported log pages (Table 96) | 00h |
| General Statistics (Table 97) | 01h |
| Free Fall Statistics (Not Support) | 02h |
| Rotating Media Statistics (Table 98) | 03h |
| General Errors Statistics (Table 99) | 04h |
| Temperature Statistics (Table 100) | 05h |
| Transport Statistics (Table 101) | 06h |
| Solid State Device Statistics (Not Support) | 07h |
| Reserved | 08h..Ffh |

Table 151 Defined Device Statistics Log Pages

11.23.3.1 List of Supported Device Statistics Log Pages (log page 00h)

The List of Supported Device Statistics log pages contains a list of the supported device statistics log pages as described in Table 96. Entries are in order of ascending log page number. Every log page for which there is at least one supported statistic is listed.

| Description | Bytes | Offset |
|--|-------|-------------|
| Device Statistics Information Header. This device statistics log page lists the number of the supported device statistics log pages. | 8 | 00h |
| Bit Description | | |
| 63:24 Reserved | | |
| 23:16 Log page number. (00h) | | |
| 15:0 Revision number. (0001h) | | |
| Number of entries (n) in the following list | 1 | 08h |
| Log page number of first supported device statistics log page (00h) | 1 | 09h |
| Log page number of second supported device statistics log page | 1 | 0ah |
| ... | | |
| Log page number of nth supported device statistics log page | 1 | n+08h |
| Reserved | | n+09h..1Ffh |

Table 152 List of Supported Device Statistics Log Pages

11.23.3.2 General Statistics (log page 01h)

The General Statistics log page contains general information about the device as described in Table 95.

| Description | | Bytes | Offset |
|--------------------------------------|--|-------|----------|
| Device Statistics Information Header | | | |
| Bit | Description | | |
| 63:24 | Reserved | 8 | 00h |
| 23:16 | Log page number. (01h) | | |
| 15:0 | Revision number. (0002h) | | |
| Lifetime Power-On Resets | | | |
| Bit | Description | | |
| 63:56 | Device Statistics Flags | 8 | 08h |
| 55:32 | Reserved | | |
| 31:0 | Number of times that the device has processed a Power-On Reset event (DWord) | | |
| Power-on Hours | | | |
| Bit | Description | | |
| 63:32 | Reserved | 8 | 10h |
| 31:0 | Power-on Hours (DWord) | | |
| Logical Sectors Written | | | |
| Bit | Description | | |
| 63:56 | Device Statistics Flags | 8 | 18h |
| 55:48 | Reserved | | |
| 47:0 | Logical Sectors Written | | |
| Number of Write Commands | | | |
| Bit | Description | | |
| 63:56 | Device Statistics Flags | 8 | 20h |
| 55:48 | Reserved | | |
| 47:0 | Number of Write Commands | | |
| Logical Sectors Read | | | |
| Bit | Description | | |
| 63:56 | Device Statistics Flags | 8 | 28h |
| 55:48 | Reserved | | |
| 47:0 | Logical Sectors Read | | |
| Number of Read Commands | | | |
| Bit | Description | | |
| 63:56 | Device Statistics Flags | 8 | 30h |
| 55:48 | Reserved | | |
| 47:0 | Number of Read Commands | | |
| Reserved | | 1 | 38h..1Fh |

Table 153 General Statistics

11.23.3.3 Rotating Media Statistics (log page 03h)

The Rotating Media Statics log page contains device rotating media information as described in Table 98.

| Description | | Bytes | Offset |
|---------------------------------------|---|-------|----------|
| Device Statistics Information Header | | 8 | 00h |
| Bit | Description | | |
| 63:24 | Reserved | | |
| 23:16 | Log page number. (03h) | | |
| 15:0 | Revision number. (0001h) | | |
| Spindle Motor Power-on Hours | | 8 | 08h |
| Bit | Description | | |
| 63:56 | Device Statistics Flags | | |
| 55:32 | Reserved | | |
| 31:0 | Spindle Motor Power-on Hours (DWord) | | |
| Head Flying Hours | | 8 | 10h |
| Bit | Description | | |
| 63:56 | Device Statistics Flags | | |
| 55:32 | Reserved | | |
| 31:0 | Head Flying Hours (DWord) | | |
| Head Load Events | | 8 | 18h |
| Bit | Description | | |
| 63:56 | Device Statistics Flags | | |
| 55:32 | Reserved | | |
| 31:0 | Head Load Events (DWord) | | |
| Number of Reallocated Logical Sectors | | 8 | 20h |
| Bit | Description | | |
| 63:56 | Device Statistics Flags | | |
| 55:32 | Reserved | | |
| 31:0 | Number of Reallocated Logical Sectors (DWord) | | |
| Read Recovery Attempts | | 8 | 28h |
| Bit | Description | | |
| 63:56 | Device Statistics Flags | | |
| 55:32 | Reserved | | |
| 31:0 | Read Recovery Attempts (DWord) | | |
| Number of Mechanical Start Failures | | 8 | 30h |
| Bit | Description | | |
| 63:56 | Device Statistics Flags | | |
| 55:32 | Reserved | | |
| 31:0 | Number of Mechanical Start Failures (DWord) | | |
| Reserved | | 1 | 38h..1Fh |

Table 154 Rotating Media Statistics

11.23.3.4 General Errors Statistics (log page 04h)

General Errors Statistics log page contains general error information about the device as described in Table 99

| Description | | Bytes | Offset |
|--|--|-------|----------|
| Device Statistics Information Header | | 8 | 00h |
| Bit | Description | | |
| 63:24 | Reserved | | |
| 23:16 | Log page number. (04h) | | |
| 15:0 | Revision number. (0001h) | 8 | 08h |
| Number of Reported Uncorrectable Errors | | | |
| Bit | Description | | |
| 63:56 | Device Statistics Flags | | |
| 55:32 | Reserved | 8 | 10h |
| 31:0 | Number of Reported Uncorrectable Errors (DWord) | | |
| Number of Resets Between Command Acceptance and Command Completion | | 8 | 10h |
| Bit | Description | | |
| 63:56 | Device Statistics Flags | | |
| 55:32 | Reserved | | |
| 31:0 | Number of Resets Between Command Acceptance and Command Completion (DWord) | 1 | 18h..1Fh |
| Reserved | | | |

Table 155 General Error Statistics

11.23.3.5 Temperature Statistics (log page 05h)

The Temperature Statistics log page contains general information about the device as described in Table 100.

The value in the temperature field is a two's complement integer in degrees Celsius.

| Description | | Bytes | Offset |
|--------------------------------------|--|-------|--------|
| Device Statistics Information Header | | 8 | 00h |
| Bit | Description | | |
| 63:24 | Reserved | | |
| 23:16 | Log page number. (05h) | | |
| 15:0 | Revision number. (0001h) | 8 | 08h |
| Current Temperature | | | |
| Bit | Description | | |
| 63:56 | Device Statistics Flags | | |
| 55:8 | Reserved | 8 | 10h |
| 7:0 | Current Temperature (signed byte) | | |
| Average Short Term Temperature | | 8 | 10h |
| Bit | Description | | |
| 63:56 | Device Statistics Flags | | |
| 55:8 | Reserved | | |
| 7:0 | Average Short Term Temperature (signed byte) | 8 | 18h |
| Average Long Term Temperature | | | |
| Bit | Description | | |
| 63:56 | Device Statistics Flags | | |
| 55:8 | Reserved | 8 | 18h |
| 7:0 | Average Long Term Temperature (signed byte) | | |

Table 156 Temperature Statistics (Part 1 of 2)

| | | | |
|---|---|---|----------|
| Highest Temperature | | 8 | 20h |
| Bit | Description | | |
| 63:56 | Device Statistics Flags | | |
| 55:8 | Reserved | | |
| 7:0 | Highest Temperature (signed byte) | | |
| Lowest Temperature | | 8 | 28h |
| Bit | Description | | |
| 63:56 | Device Statistics Flags | | |
| 55:8 | Reserved | | |
| 7:0 | Lowest Temperature (signed byte) | | |
| Highest Average Short Term Temperature | | 8 | 30h |
| Bit | Description | | |
| 63:56 | Device Statistics Flags | | |
| 55:8 | Reserved | | |
| 7:0 | Highest Average Short Term Temperature (signed byte) | | |
| Lowest Average Short Term Temperature | | 8 | 38h |
| Bit | Description | | |
| 63:56 | Device Statistics Flags | | |
| 55:8 | Reserved | | |
| 7:0 | Lowest Average Short Term Temperature (signed byte) | | |
| Highest Average Long Term Temperature | | 8 | 40h |
| Bit | Description | | |
| 63:56 | Device Statistics Flags | | |
| 55:8 | Reserved | | |
| 7:0 | Highest Average Long Term Temperature (signed byte) | | |
| Lowest Average Long Term Temperature | | 8 | 48h |
| Bit | Description | | |
| 63:56 | Device Statistics Flags | | |
| 55:8 | Reserved | | |
| 7:0 | Lowest Average Long Term Temperature (signed byte) | | |
| Time in Over-Temperature | | 8 | 50h |
| Bit | Description | | |
| 63:56 | Device Statistics Flags | | |
| 55:32 | Reserved | | |
| 31:0 | Time in Over-Temperature (DWord) | | |
| Specified Maximum Operating Temperature | | 8 | 58h |
| Bit | Description | | |
| 63:56 | Device Statistics Flags | | |
| 55:8 | Reserved | | |
| 7:0 | Specified Maximum Operating Temperature (signed byte) | | |
| Time in Under-Temperature | | 8 | 60h |
| Bit | Description | | |
| 63:56 | Device Statistics Flags | | |
| 55:32 | Reserved | | |
| 31:0 | Time in Under-Temperature (DWord) | | |
| Specified Minimum Operating Temperature | | 8 | 68h |
| Bit | Description | | |
| 63:56 | Device Statistics Flags | | |
| 55:8 | Reserved | | |
| 7:0 | Specified Minimum Operating Temperature (signed byte) | | |
| Reserved | | 1 | 70h..1Fh |

Table 157 Temperature Statistics (Part 2 of 2)

Table 157 Temperature Statistics (Part 2 of 2)

11.23.3.6 Transport Statistics (log page 06h)

The Transport Statistics log page contains interface transport information about the device as described in Table 101.

| Description | | Bytes | Offset |
|--------------------------------------|--|-------|----------|
| Device Statistics Information Header | | 8 | 00h |
| Bit | Description | | |
| 63:24 | Reserved | | |
| 23:16 | Log page number. (06h) | | |
| 15:0 | Revision number. (0001h) | | |
| Number of hardware resets | | 8 | 08h |
| Bit | Description | | |
| 63:56 | Device Statistics Flags | | |
| 55:32 | Reserved | | |
| 31:0 | Number of hardware resets (DWord) | | |
| Number of ASR Events | | 8 | 10h |
| Bit | Description | | |
| 63:56 | Device Statistics Flags | | |
| 55:32 | Reserved | | |
| 31:0 | Number of ASR Events (DWord) | | |
| Head Load Events | | 8 | 18h |
| Bit | Description | | |
| 63:56 | Device Statistics Flags | | |
| 55:32 | Reserved | | |
| 31:0 | Head Load Events (DWord) | | |
| Number of Interface CRC Errors | | 8 | 20h |
| Bit | Description | | |
| 63:56 | Device Statistics Flags | | |
| 55:32 | Reserved | | |
| 31:0 | Number of Interface CRC Errors (DWord) | | |
| Reserved | | 1 | 28h..1Fh |

Table 158 Transport Statistics

11.23.4 Extended Self-Test Log Sector

Table 159 defines the format of each of the sectors that comprise the Extended SMART self-test log.

The Extended SMART self-test log sector shall support 48-bit and 28-bit addressing. All 28-bit entries contained in the SMART self-test log, defined in 11.52.6 Self-Test Log Data Structure on page 293 shall also be included in the Extended SMART self-test log with all 48-bit entries.

| Description | Bytes | Offset |
|--|-------|--------|
| Self-test log data structure revision number | 1 | 00h |
| Reserved | 1 | 01h |
| Self-test descriptor index (7:0) | 1 | 02h |
| Self-test descriptor index (15:8) | 1 | 03h |
| Descriptor entry 1 | 26 | 04h |
| Descriptor entry 2 | 26 | 1Eh |
| ... | | |
| Descriptor entry 18 | 26 | 1D8h |
| Vendor specific | 2 | 1F2h |
| Reserved | 11 | 1F4h |
| Data structure checksum | 1 | 1FFh |
| | 512 | |

Table 159 Extended Self-Test Log Data Structure

These descriptor entries are viewed as a circular buffer. The nineteenth self-test shall create a descriptor entry that replaces descriptor entry 1. The next self-test after that shall create a descriptor entry that replaces descriptor entry 2, etc. All unused self-test descriptors shall be filled with zeros.

11.23.4.1 Self-Test Log Data Structure Revision Number

The value of this revision number shall be 01h.

11.23.4.2 Self-Test Descriptor Index

This indicates the most recent self-test descriptor. If there have been no self-tests, this is set to zero. Valid values for the Self-test descriptor index are 0 to 18.

11.23.4.3 Extended Self-test Log Descriptor Entry

The content of the self-test descriptor entry is shown below.

| Description | Bytes | Offset |
|----------------------------------|-------|--------|
| Self-test number | 1 | 00h |
| Self-test execution status | 1 | 01h |
| Power-on life timestamp in hours | 2 | 02h |
| Self-test failure check point | 1 | 04h |
| Failing LBA (7:0) | 1 | 05h |
| Failing LBA (15:8) | 1 | 06h |
| Failing LBA (23:16) | 1 | 07h |
| Failing LBA (31:24) | 1 | 08h |
| Failing LBA (39:32) | 1 | 09h |
| Failing LBA (47:40) | 1 | 0Ah |
| Vendor specific | 15 | 0Bh |
| | 26 | |

Table 160 Extended Self-Test Log Descriptor Entry

11.23.5 Power Conditions Log

Defines the Power Conditions log. If the Extended Power Conditions feature set is not supported, then the Power Conditions log not is supported. Each Power is composed of the following formats.

Idle power conditions (log page 00h)

| Offset | Type | Description |
|---------|------|--|
| 0-63 | Byte | Idle_a power conditions descriptor. Power condition supported is set to one to indicate that the idle_a power condition is supported. |
| 64-127 | Byte | Idle_b power conditions descriptor. Power condition supported is set to one to indicate that the idle_b power condition is supported. |
| 128-191 | Byte | Idle_c power conditions descriptor. Power condition supported is set to one to indicate that the idle_c power condition is supported. |
| 192-511 | Byte | Reserved |

Table 161 Idle Power Conditions (log page 00h)

Standby power conditions (log page 01h)

| Offset | Type | Description |
|---------|------|--|
| 0-383 | Byte | Reserved |
| 384-447 | Byte | Standby_y power conditions descriptor. Power condition supported is set to one to indicate that the standby_y power condition is supported. |
| 448-511 | Byte | Standby_z power conditions descriptor. Power condition supported is set to one to indicate that the standby_z power condition is supported. |

Table 162 Standby Power Conditions (log page 01h)

Power Conditions log descriptor

| Offset | Type | Description | | | | | | | | | | | | | | | | |
|--------|--|---|-----|-------------|---|--|---|---|---|---|---|--|---|--|---|--|-----|----------|
| 0 | Byte | Reserved | | | | | | | | | | | | | | | | |
| 1 | Byte | <p>Power Condition Flags</p> <table border="0"> <tr> <td>Bit</td> <td>Description</td> </tr> <tr> <td>7</td> <td> <p>Power Condition Supported</p> <p>The Power Condition Supported bit is valid if the EPC feature set is supported, regardless of whether EPC is enabled or disabled. If the Power Condition Supported bit is set to one, then the power condition is supported. If the Power Condition Supported bit is cleared to zero, then the power condition is not supported.</p> </td> </tr> <tr> <td>6</td> <td> <p>Timer Savable</p> <p>The Timer Savable bit is valid if the Power Condition Supported bit is set to one, regardless of whether EPC is enabled or disabled. If the Timer Savable bit is set to one, then the power condition is savable if EPC is enabled. If the Timer Savable bit is cleared to zero, then the power condition is not savable.</p> </td> </tr> <tr> <td>5</td> <td> <p>Timer Changeable</p> <p>The Timer Changeable bit is valid if the Power Condition Supported bit is set to one, regardless of whether EPC is enabled or disabled. If the Timer Changeable bit is set to one, then the power condition is changeable if EPC is enabled. If the Timer Changeable bit is cleared to zero, then the power condition is not changeable.</p> </td> </tr> <tr> <td>4</td> <td> <p>Default Timer Enabled</p> <p>The Default Timer Enabled bit is valid if the Power Condition Supported bit is set to one, regardless of whether EPC is enabled or disabled.</p> </td> </tr> <tr> <td>3</td> <td> <p>Saved Timer Enabled</p> <p>The Saved Timer Enabled bit is valid if the Power Condition Supported bit is set to one, regardless of whether EPC is enabled or disabled.</p> </td> </tr> <tr> <td>2</td> <td> <p>Current Timer Enabled</p> <p>If EPC is disabled, then the Current Timer Enabled bit shall be cleared to zero. If EPC is enabled and the Current Timer Setting field is non-zero and the Current Timer Enabled bit is set to one, then the power condition timer is enabled. If EPC is enabled and the Current Timer Enabled bit is cleared to zero, then the power condition timer is disabled.</p> </td> </tr> <tr> <td>1-0</td> <td>Reserved</td> </tr> </table> | Bit | Description | 7 | <p>Power Condition Supported</p> <p>The Power Condition Supported bit is valid if the EPC feature set is supported, regardless of whether EPC is enabled or disabled. If the Power Condition Supported bit is set to one, then the power condition is supported. If the Power Condition Supported bit is cleared to zero, then the power condition is not supported.</p> | 6 | <p>Timer Savable</p> <p>The Timer Savable bit is valid if the Power Condition Supported bit is set to one, regardless of whether EPC is enabled or disabled. If the Timer Savable bit is set to one, then the power condition is savable if EPC is enabled. If the Timer Savable bit is cleared to zero, then the power condition is not savable.</p> | 5 | <p>Timer Changeable</p> <p>The Timer Changeable bit is valid if the Power Condition Supported bit is set to one, regardless of whether EPC is enabled or disabled. If the Timer Changeable bit is set to one, then the power condition is changeable if EPC is enabled. If the Timer Changeable bit is cleared to zero, then the power condition is not changeable.</p> | 4 | <p>Default Timer Enabled</p> <p>The Default Timer Enabled bit is valid if the Power Condition Supported bit is set to one, regardless of whether EPC is enabled or disabled.</p> | 3 | <p>Saved Timer Enabled</p> <p>The Saved Timer Enabled bit is valid if the Power Condition Supported bit is set to one, regardless of whether EPC is enabled or disabled.</p> | 2 | <p>Current Timer Enabled</p> <p>If EPC is disabled, then the Current Timer Enabled bit shall be cleared to zero. If EPC is enabled and the Current Timer Setting field is non-zero and the Current Timer Enabled bit is set to one, then the power condition timer is enabled. If EPC is enabled and the Current Timer Enabled bit is cleared to zero, then the power condition timer is disabled.</p> | 1-0 | Reserved |
| Bit | Description | | | | | | | | | | | | | | | | | |
| 7 | <p>Power Condition Supported</p> <p>The Power Condition Supported bit is valid if the EPC feature set is supported, regardless of whether EPC is enabled or disabled. If the Power Condition Supported bit is set to one, then the power condition is supported. If the Power Condition Supported bit is cleared to zero, then the power condition is not supported.</p> | | | | | | | | | | | | | | | | | |
| 6 | <p>Timer Savable</p> <p>The Timer Savable bit is valid if the Power Condition Supported bit is set to one, regardless of whether EPC is enabled or disabled. If the Timer Savable bit is set to one, then the power condition is savable if EPC is enabled. If the Timer Savable bit is cleared to zero, then the power condition is not savable.</p> | | | | | | | | | | | | | | | | | |
| 5 | <p>Timer Changeable</p> <p>The Timer Changeable bit is valid if the Power Condition Supported bit is set to one, regardless of whether EPC is enabled or disabled. If the Timer Changeable bit is set to one, then the power condition is changeable if EPC is enabled. If the Timer Changeable bit is cleared to zero, then the power condition is not changeable.</p> | | | | | | | | | | | | | | | | | |
| 4 | <p>Default Timer Enabled</p> <p>The Default Timer Enabled bit is valid if the Power Condition Supported bit is set to one, regardless of whether EPC is enabled or disabled.</p> | | | | | | | | | | | | | | | | | |
| 3 | <p>Saved Timer Enabled</p> <p>The Saved Timer Enabled bit is valid if the Power Condition Supported bit is set to one, regardless of whether EPC is enabled or disabled.</p> | | | | | | | | | | | | | | | | | |
| 2 | <p>Current Timer Enabled</p> <p>If EPC is disabled, then the Current Timer Enabled bit shall be cleared to zero. If EPC is enabled and the Current Timer Setting field is non-zero and the Current Timer Enabled bit is set to one, then the power condition timer is enabled. If EPC is enabled and the Current Timer Enabled bit is cleared to zero, then the power condition timer is disabled.</p> | | | | | | | | | | | | | | | | | |
| 1-0 | Reserved | | | | | | | | | | | | | | | | | |
| 2-3 | Byte | Reserved | | | | | | | | | | | | | | | | |
| 4-7 | DWord | <p>Default Timer setting</p> <p>The Default Timer field is set at the time of manufacture.</p> <p>The Default Timer Setting field is valid if the Power Condition Supported bit is set to one, regardless of whether EPC is enabled or disabled. A value of FFFF_FFFFh indicates that the time is greater than or equal to 429_496_729_500 milliseconds.</p> <p>Measurement Units: 100 milliseconds.</p> | | | | | | | | | | | | | | | | |
| 8-11 | DWord | <p>Saved Timer setting</p> <p>The Saved Timer Setting field is a value that has been saved by a SET FEATURES Set Power Condition Timer subcommand. The Saved Timer Setting field is valid if the Power Condition Supported bit is set to one, regardless of whether EPC is enabled or disabled. A value of zero indicates that this power condition is disabled if the EPC feature set is enabled. A value of FFFF_FFFFh indicates that the time is greater than or equal to 429_496_729_500 milliseconds.</p> <p>Measurement Units: 100 milliseconds.</p> | | | | | | | | | | | | | | | | |

Table 163 Power Condition Log Description

| Offset | Type | Description |
|--------|-------|---|
| 12-15 | DWord | <p>Current Timer setting</p> <p>The Current Timer setting is the minimum time that the device shall wait after command completion before entering this power condition if the EPC feature set is enabled. The Current Timer Setting field shall be cleared to zero if:</p> <ul style="list-style-type: none"> a) EPC is disabled; b) the Power Condition Supported bit is cleared to zero; or c) the Current Timer Enabled field is cleared to zero. <p>A value of FFFF_FFFFh indicates that the time is greater than or equal to 429_496_729_500 milliseconds.</p> <p>Measurement Units: 100 milliseconds</p> |
| 16-19 | DWord | <p>Nominal Recovery time from to PM0:Active power management state</p> <p>The Nominal Recovery time from power to PM0: Active is the nominal time required to transition from power to PM0: Active power management state. This time does not include processing time for the command that caused this transition to occur. A value of zero indicates that the nominal recovery time is not specified. A value of FFFF_FFFFh indicates that the recovery time is greater than or equal to 429 496 729 500 milliseconds.</p> <p>Measurement Units: 100 milliseconds.</p> <p>This value is preserved over all resets.</p> |
| 20-23 | DWord | <p>Minimum timer setting</p> <p>The Minimum timer setting is the minimum timer value allowed by the Set Power Condition Timer subcommand for the timer. A value of zero indicates that the minimum timer value is not specified. A value of FFFF_FFFFh indicates that the minimum timer value is greater than or equal to 429 496 729 500 milliseconds.</p> <p>Measurement Units: 100 milliseconds</p> <p>This value be preserved over all resets</p> |
| 24-27 | DWord | <p>Maximum timer setting</p> <p>The Maximum timer setting is the maximum timer value allowed by the Set Power Condition Timer subcommand for the timer. A value of zero indicates that the maximum timer value is not specified. A value of FFFF_FFFFh indicates that the maximum timer value is greater than or equal to 429 496 729 500 milliseconds.</p> <p>Measurement Units: 100 milliseconds</p> <p>This value be preserved over all resets</p> |
| 28-63 | DWord | Reserved |

Table 164 Power Condition Log Description - Continued -

11.23.6 Queued Error Log

Table 165 defines the format of the Queued Error Log data structure.

| Byte | 7 | 6 | 5 | 4 | 3 | 2 | 1 | 0 |
|-----------|---------------------------------|-----|---|-----|---|---|---|---|
| 0 | NQ | UNL | R | TAG | | | | |
| 1 | Reserved | | | | | | | |
| 2 | Status(7:0) | | | | | | | |
| 3 | Error(7:0) | | | | | | | |
| 4 | LBA(7:0) | | | | | | | |
| 5 | LBA(15:8) | | | | | | | |
| 6 | LBA(23:16) | | | | | | | |
| 7 | Device(7:0) | | | | | | | |
| 8 | LBA(31:24) | | | | | | | |
| 9 | LBA(39:32) | | | | | | | |
| 10 | LBA(47:40) | | | | | | | |
| 11 | Reserved | | | | | | | |
| 12 | Count(7:0) | | | | | | | |
| 13 | Count(15:8) | | | | | | | |
| 14 | Sense Key | | | | | | | |
| 15 | Additional Sense Code | | | | | | | |
| 16 | Additional Sense Code Qualifier | | | | | | | |
| 17 | Final LBA In Error(7:0) | | | | | | | |
| 18 | Final LBA In Error(15:8) | | | | | | | |
| 19 | Final LBA In Error(23:16) | | | | | | | |
| 20 | Final LBA In Error(31:24) | | | | | | | |
| 21 | Final LBA In Error(39:32) | | | | | | | |
| 22 | Final LBA In Error(47:40) | | | | | | | |
| 23 – 255 | Reserved | | | | | | | |
| 256 – 510 | Vendor Unique | | | | | | | |
| 511 | Data Structure Checksum | | | | | | | |

Table 165 Queued Error Log Data Structure Definition

The TAG field (Byte 0 Bits 4-0) contains the tag number corresponding to a queued command if the NQ bit is cleared.

The NQ field (Byte 0 Bit 7) indicates whether the error condition was a result of a non-queued or not. If it is cleared the error information corresponds to a queued command specified by the tag number indicated in the TAG field.

The bytes 1 to 13 correspond to the contents of Shadow Register Block when the error was reported.

The Data Structure Checksum (Byte 511) contains the 2's complement of the sum of the first 511 bytes in the data structure. The sum of all 512 bytes of the data structure will be zero when the checksum is correct.

11.23.7 Read Stream Error Log

Table 166 defines the format of the Read Stream Error log. Entries are placed into the Read Stream Error log only when the SE bit is set to one in the Status Register. The 512 bytes returned shall contain a maximum of 31 error entries. The Read Stream Error Count shall contain the total number of Read Stream Errors detected since the last successful completion of the Read Log Ext command with LBA Low register set to 22h. This error count may be greater than 31, but only the most recent 31 errors are represented by entries in the log. If the Read Stream Error Count reaches the maximum value that can be represented after the next error is detected the Read Stream Error Count shall remain at the maximum value. After successful completion of a Read Log Ext command with the LBA Low Register set to 22h, the Read Stream Error Log shall be reset to a power-on or hardware reset condition, with the Error Log Index and Read Stream Error Count cleared to zero. The Read Stream Error Log is not preserved across power cycles and hardware reset.

| Description | Bytes | Offset |
|---------------------------------|-------|--------|
| Structure Version | 1 | 00h |
| Error Log Index | 1 | 01h |
| Read Stream Error Log Count | 2 | 02h |
| Reserved | 12 | 04h |
| Read Stream Error Log Entry #1 | 16 | 10h |
| Read Stream Error Log Entry #2 | 16 | 20h |
| ... | | |
| Read Stream Error Log Entry #31 | 16 | 1F0h |
| | 512 | |

Table 166 Read Stream Error Log

The Data Structure Version field shall contain a value of 02h indicating the second revision of the structure format.

The Read Stream Error Log Count field shall contain the number of uncorrected sector entries currently reportable to the host. This value may exceed 31.

The Error Log Index indicates the error log data structure representing the most recent error. Only values (31:1) are valid.

Table 166 defines the format of each entry in the Read Stream Error Log.

| Description | Bytes | Offset |
|--|-------|--------|
| Feature Register Contents Value (current) | 1 | 00h |
| Feature Register Contents Value (previous) | 1 | 01h |
| Status Register Contents Value | 1 | 02h |
| Error Register Contents Value | 1 | 03h |
| LBA (7:0) | 1 | 04h |
| LBA (15:8) | 1 | 05h |
| LBA (23:16) | 1 | 06h |
| LBA (31:24) | 1 | 07h |
| LBA (39:32) | 1 | 08h |
| LBA (47:40) | 1 | 09h |
| Reserved | 2 | 0A-0Bh |
| Sector Count (LSB) | 1 | 0Ch |
| Sector Count (MSB) | 1 | 0Dh |
| Reserved | 2 | 0E-0Fh |

Table 167 Stream Error Log Entry

Byte (1:0) contains the contents of the Feature Register when the error occurred. This Value shall be set to 0FFFFh for s deferred write error.

Byte 2 contains the contents of the Status Register when the error occurred.

Byte 3 contains the contents of the Error Register when the error occurred.

Byte (9:4) indicates the starting LBA of the error.

Byte (13:12) indicate the length of the error. Therefore, each entry may describe a range of sectors at the given address and spanning the specified number of sectors.

11.23.8 Write Stream Error Log

Table 168 defines the format of the Write Stream Error log. Entries are placed into the Write Stream Error log only when the SE bit is set to one in the Status Register. The 512 bytes returned shall contain a maximum of 31 error entries. The Write Stream Error Count shall contain the total number of Write Stream Errors detected since the last successful completion of the Read Log Ext command with LBA Low register set to 21h. This error count may be greater than 31, but only the most 31 errors are represented by entries in the log. If the Write Stream Error Count reaches the maximum value that can be represented after the next error is detected the Write Stream Error Count shall remain at the maximum value. After successful completion of a Read Log Ext command with the LBA Low Register set to 21h, the Write Stream Error Log shall be reset to a power-on or hardware reset condition, with the Error Log Index and Write Stream Error Count cleared to zero. The Write Stream Error Log is not reserved across power cycles and hardware reset.

| Description | Bytes | Offset |
|----------------------------------|-------|--------|
| Structure Version | 1 | 00h |
| Error Log Index | 1 | 01h |
| Write Stream Error Log Count | 2 | 02h |
| Reserved | 12 | 04h |
| Write Stream Error Log Entry #1 | 16 | 10h |
| Write Stream Error Log Entry #2 | 16 | 20h |
| ... | | |
| Write Stream Error Log Entry #31 | 16 | 1F0h |
| | 512 | |

Table 168 Write Stream Error Log

The Data Structure Version field shall contain a value of 02h indicating the second revision of the structure format.

The Write Stream Error Log Count field shall contain the number of Write Stream command entries since the last power on, since this log was last read, or since hardware reset was executed.

The Error Log Index indicates the error log data structure representing the most recent error. Only values (31:0) are valid.

Table 166 defines the format of each entry in the Error Log.

11.23.9 Sector Configuration Log

Table 169 Sector Configuration Log defines the format of the Sector Configuration log which contains Sector Configuration descriptors. The Sector Configuration descriptors describe sector configurations. The sector configuration is specified using the Set Sector Configuration Ext command (See section 11.5 Section Set Sector Configuration Ext).

| Description | Bytes | Offset |
|--|-------|--------|
| Sector Configuration descriptor Entry #0 | 16 | 00h |
| Sector Configuration descriptor Entry #1 | 16 | 10h |
| ... | | |
| Sector Configuration descriptor Entry #7 | 16 | 70h |
| Reserved | 384 | 80h |
| | 512 | |

Table 169 Sector Configuration Log

11.23.9.1 Sector Configuration Descriptor

The content of the Sector Configuration Descriptor entry is shown below.

| Description | | Bytes | Offset |
|---|----------------------|-------|--------|
| Sector Configuration descriptor flags | | 1 | 00h |
| Bit | Description | | |
| 7 | Descriptor Valid bit | | |
| 6:0 | Reserved | | |
| Logical To Physical Sector Relationship Setting field | | 1 | 01h |
| Descriptor Check field | | 2 | 02h |
| Logical Sector Size Setting field | | 4 | 04h |
| Reserved | | 8 | 08h |
| | | 16 | |

Table 170 Sector Configuration Descriptor

11.23.10 Identify Device Data Log

IDENTIFY DEVICE data log reports device configuration information. This log is read-only. See Table 99 for a list of defined pages. Each page consists of a header field that is followed by defined statistics fields. If the Revision Number field in the page header is 0000h, then that page is not supported. All page data following the last defined statistic for that page is reserved.

| Description | Page |
|------------------------------|----------|
| List of supported pages | 00h |
| Copy of IDENTIFY DEVICE data | 01h |
| Capacity | 02h |
| Supported Capabilities | 03h |
| Current Settings | 04h |
| ATA Strings | 05h |
| Security | 06h |
| Reserved for Parallel ATA | 07h |
| Serial ATA | 08h |
| Reserved | 09h..FFh |

Table 171 Identify Device Data Log

11.23.10.1 List of Supported IDENTIFY DEVICE Data Log Pages (Page 00h)

IDENTIFY DEVICE data log page 00h contains a list of the supported pages. Entries are in order of ascending page number (e.g., 00h, 01h, 07h).

| Offset | Type | Content |
|----------|-------|---|
| 0..7 | QWord | IDENTIFY DEVICE data log Information Header. This log page lists the numbers of the supported log pages |
| | | Bit Meaning |
| | | 63:24 Reserved |
| | | 23:16 Page Number. Set to 00h. 15:0 Revision number. Set to 0001h |
| 8 | Byte | Number of entries (n) in the following list |
| 9 | Byte | Set to zero to indicate that page 00h is supported |
| 10 | Byte | Set to one to indicate that page 01h is supported |
| ... | | |
| n+8 | Byte | Page number of nth supported IDENTIFY DEVICE data log page |
| n+9..511 | | Reserved |

Table 172 List of Supported IDENTIFY DEVICE Data Pages

11.23.10.2 Copy of IDENTIFY DEVICE Data (page 01h)

This page is a copy of IDENTIFY DEVICE data words 0..255.

11.23.10.3 Capacity (page 02h)

The Capacity log page provides information about the capacity of the device.

| Offset | Type | Content | | | | | | | | | | | | | | |
|---------|---|--|-----|---------|----|---------------------------------|--------|---|-------|-----------------------------------|-------|--|-------|---------------------------------|-------|---|
| 0..7 | QWord | Capacity page information header | | | | | | | | | | | | | | |
| | | <table border="0"> <thead> <tr> <th>Bit</th> <th>Meaning</th> </tr> </thead> <tbody> <tr> <td>63</td> <td>Set to one.</td> </tr> <tr> <td>62:24</td> <td>Reserved</td> </tr> <tr> <td>23:16</td> <td>Page Number. Shall be set to 02h.</td> </tr> <tr> <td>15:0</td> <td>Revision number. Shall be set to 0001h</td> </tr> </tbody> </table> | Bit | Meaning | 63 | Set to one. | 62:24 | Reserved | 23:16 | Page Number. Shall be set to 02h. | 15:0 | Revision number. Shall be set to 0001h | | | | |
| Bit | Meaning | | | | | | | | | | | | | | | |
| 63 | Set to one. | | | | | | | | | | | | | | | |
| 62:24 | Reserved | | | | | | | | | | | | | | | |
| 23:16 | Page Number. Shall be set to 02h. | | | | | | | | | | | | | | | |
| 15:0 | Revision number. Shall be set to 0001h | | | | | | | | | | | | | | | |
| 8..15 | QWord | Device Capacity | | | | | | | | | | | | | | |
| | | <table border="0"> <thead> <tr> <th>Bit</th> <th>Meaning</th> </tr> </thead> <tbody> <tr> <td>63</td> <td>Set to one.</td> </tr> <tr> <td>62:48</td> <td>Reserved</td> </tr> <tr> <td>47:0</td> <td>ACCESSIBLE CAPACITY field</td> </tr> </tbody> </table> | Bit | Meaning | 63 | Set to one. | 62:48 | Reserved | 47:0 | ACCESSIBLE CAPACITY field | | | | | | |
| Bit | Meaning | | | | | | | | | | | | | | | |
| 63 | Set to one. | | | | | | | | | | | | | | | |
| 62:48 | Reserved | | | | | | | | | | | | | | | |
| 47:0 | ACCESSIBLE CAPACITY field | | | | | | | | | | | | | | | |
| 16..23 | QWord | Physical/Logical Sector Size | | | | | | | | | | | | | | |
| | | <table border="0"> <thead> <tr> <th>Bit</th> <th>Meaning</th> </tr> </thead> <tbody> <tr> <td>63</td> <td>Contents of the QWord are valid</td> </tr> <tr> <td>62</td> <td>LOGICAL TO PHYSICAL SECTOR RELATIONSHIP SUPPORTED bit</td> </tr> <tr> <td>61</td> <td>LOGICAL SECTOR SIZE SUPPORTED bit</td> </tr> <tr> <td>60:22</td> <td>Reserved</td> </tr> <tr> <td>21:20</td> <td>ALIGNMENT ERROR REPORTING field</td> </tr> <tr> <td>19:16</td> <td>LOGICAL TO PHYSICAL SECTOR RELATIONSHIP field</td> </tr> <tr> <td>15:0</td> <td>LOGICAL SECTOR OFFSET field</td> </tr> </tbody> </table> | Bit | Meaning | 63 | Contents of the QWord are valid | 62 | LOGICAL TO PHYSICAL SECTOR RELATIONSHIP SUPPORTED bit | 61 | LOGICAL SECTOR SIZE SUPPORTED bit | 60:22 | Reserved | 21:20 | ALIGNMENT ERROR REPORTING field | 19:16 | LOGICAL TO PHYSICAL SECTOR RELATIONSHIP field |
| Bit | Meaning | | | | | | | | | | | | | | | |
| 63 | Contents of the QWord are valid | | | | | | | | | | | | | | | |
| 62 | LOGICAL TO PHYSICAL SECTOR RELATIONSHIP SUPPORTED bit | | | | | | | | | | | | | | | |
| 61 | LOGICAL SECTOR SIZE SUPPORTED bit | | | | | | | | | | | | | | | |
| 60:22 | Reserved | | | | | | | | | | | | | | | |
| 21:20 | ALIGNMENT ERROR REPORTING field | | | | | | | | | | | | | | | |
| 19:16 | LOGICAL TO PHYSICAL SECTOR RELATIONSHIP field | | | | | | | | | | | | | | | |
| 15:0 | LOGICAL SECTOR OFFSET field | | | | | | | | | | | | | | | |
| 24..31 | QWord | Logical Sector Size | | | | | | | | | | | | | | |
| | | <table border="0"> <thead> <tr> <th>Bit</th> <th>Meaning</th> </tr> </thead> <tbody> <tr> <td>63</td> <td>Contents of the QWord are valid</td> </tr> <tr> <td>62..32</td> <td>Reserved</td> </tr> <tr> <td>31..0</td> <td>LOGICAL SECTOR SIZE field</td> </tr> </tbody> </table> | Bit | Meaning | 63 | Contents of the QWord are valid | 62..32 | Reserved | 31..0 | LOGICAL SECTOR SIZE field | | | | | | |
| Bit | Meaning | | | | | | | | | | | | | | | |
| 63 | Contents of the QWord are valid | | | | | | | | | | | | | | | |
| 62..32 | Reserved | | | | | | | | | | | | | | | |
| 31..0 | LOGICAL SECTOR SIZE field | | | | | | | | | | | | | | | |
| 32..39 | QWord | Nominal Buffer Size | | | | | | | | | | | | | | |
| | | <table border="0"> <thead> <tr> <th>Bit</th> <th>Meaning</th> </tr> </thead> <tbody> <tr> <td>63</td> <td>Contents of the QWord are valid</td> </tr> <tr> <td>62:0</td> <td>BUFFER SIZE field</td> </tr> </tbody> </table> | Bit | Meaning | 63 | Contents of the QWord are valid | 62:0 | BUFFER SIZE field | | | | | | | | |
| Bit | Meaning | | | | | | | | | | | | | | | |
| 63 | Contents of the QWord are valid | | | | | | | | | | | | | | | |
| 62:0 | BUFFER SIZE field | | | | | | | | | | | | | | | |
| 40..511 | | Reserved | | | | | | | | | | | | | | |

Table 173 Capacity Log Page

11.23.10.4 Supported Capabilities (page 03h)

The Supported Capabilities log page provides a mechanism for the device to report support for feature sets, features, commands and other device capabilities.

| Offset | Type | Content | | | | | | | | | | | | | | | | | | | | | | | | | | | | | | | | | | | | | | | | | | | | | | | | | | | | | | | | | | | | | | | | | | | | | | | | | | |
|--------|---|--|-----|---------|----|------------|-------|----------|-------|--|------|-------------------------------|----|---------------------------------|----|------------------------------------|----|-------------------------|----|------------------|----|--------------------|----|--|----|----------|----|-------------------------------|----|--------------------------------|----|----------|----|--------------------------------------|----|----------------------|----|--------------------|----|----------|----|-------------------|----|---------------------------|----|----------------------------|----|----------|----|-------------------------------|----|------------------------------------|----|-----------|----|-------------------------------|----|----------|----|----------------------|----|----------|----|-----------------------|----|--------------------|----|-------------------|----|-------------------|----|----------------------------------|----|----------------------|----|---|
| 0..7 | QWord | Supported Capabilities page information header. | | | | | | | | | | | | | | | | | | | | | | | | | | | | | | | | | | | | | | | | | | | | | | | | | | | | | | | | | | | | | | | | | | | | | | | | | | |
| | | <table border="1"> <thead> <tr> <th>Bit</th> <th>Meaning</th> </tr> </thead> <tbody> <tr> <td>63</td> <td>Set to one</td> </tr> <tr> <td>62:24</td> <td>Reserved</td> </tr> <tr> <td>23:16</td> <td>Page Number. Set to 03h</td> </tr> <tr> <td>15:0</td> <td>Revision number. Set to 0001h</td> </tr> </tbody> </table> | Bit | Meaning | 63 | Set to one | 62:24 | Reserved | 23:16 | Page Number. Set to 03h | 15:0 | Revision number. Set to 0001h | | | | | | | | | | | | | | | | | | | | | | | | | | | | | | | | | | | | | | | | | | | | | | | | | | | | | | | | | | | | | | | | |
| Bit | Meaning | | | | | | | | | | | | | | | | | | | | | | | | | | | | | | | | | | | | | | | | | | | | | | | | | | | | | | | | | | | | | | | | | | | | | | | | | | | |
| 63 | Set to one | | | | | | | | | | | | | | | | | | | | | | | | | | | | | | | | | | | | | | | | | | | | | | | | | | | | | | | | | | | | | | | | | | | | | | | | | | | |
| 62:24 | Reserved | | | | | | | | | | | | | | | | | | | | | | | | | | | | | | | | | | | | | | | | | | | | | | | | | | | | | | | | | | | | | | | | | | | | | | | | | | | |
| 23:16 | Page Number. Set to 03h | | | | | | | | | | | | | | | | | | | | | | | | | | | | | | | | | | | | | | | | | | | | | | | | | | | | | | | | | | | | | | | | | | | | | | | | | | | |
| 15:0 | Revision number. Set to 0001h | | | | | | | | | | | | | | | | | | | | | | | | | | | | | | | | | | | | | | | | | | | | | | | | | | | | | | | | | | | | | | | | | | | | | | | | | | | |
| 8..15 | QWord | Supported Capabilities | | | | | | | | | | | | | | | | | | | | | | | | | | | | | | | | | | | | | | | | | | | | | | | | | | | | | | | | | | | | | | | | | | | | | | | | | | |
| | | <table border="1"> <thead> <tr> <th>Bit</th> <th>Meaning</th> </tr> </thead> <tbody> <tr> <td>63</td> <td>Set to one</td> </tr> <tr> <td>62:46</td> <td>Reserved</td> </tr> <tr> <td>45</td> <td>REQUEST SENSE DEVICE FAULT SUPPORTED bit</td> </tr> <tr> <td>44</td> <td>DSN SUPPORTED bit</td> </tr> <tr> <td>43</td> <td>LOW POWER STANDBY SUPPORTED bit</td> </tr> <tr> <td>42</td> <td>SET EPC POWER SOURCE SUPPORTED bit</td> </tr> <tr> <td>41</td> <td>AMAX ADDR SUPPORTED bit</td> </tr> <tr> <td>40</td> <td>Reserved for CFA</td> </tr> <tr> <td>39</td> <td>DRAT SUPPORTED bit</td> </tr> <tr> <td>38</td> <td>LPS MISALIGNMENT REPORTING SUPPORTED bit</td> </tr> <tr> <td>37</td> <td>Reserved</td> </tr> <tr> <td>36</td> <td>READ BUFFER DMA SUPPORTED bit</td> </tr> <tr> <td>35</td> <td>WRITE BUFFER DMA SUPPORTED bit</td> </tr> <tr> <td>34</td> <td>Reserved</td> </tr> <tr> <td>33</td> <td>DOWNLOAD MICROCODE DMA SUPPORTED bit</td> </tr> <tr> <td>32</td> <td>28-BIT SUPPORTED bit</td> </tr> <tr> <td>31</td> <td>RZAT SUPPORTED bit</td> </tr> <tr> <td>30</td> <td>Reserved</td> </tr> <tr> <td>29</td> <td>NOP SUPPORTED bit</td> </tr> <tr> <td>28</td> <td>READ BUFFER SUPPORTED bit</td> </tr> <tr> <td>27</td> <td>WRITE BUFFER SUPPORTED bit</td> </tr> <tr> <td>26</td> <td>Reserved</td> </tr> <tr> <td>25</td> <td>READ LOOK-AHEAD SUPPORTED bit</td> </tr> <tr> <td>24</td> <td>VOLATILE WRITE CACHE SUPPORTED bit</td> </tr> <tr> <td>23</td> <td>SMART bit</td> </tr> <tr> <td>22</td> <td>FLUSH CACHE EXT SUPPORTED bit</td> </tr> <tr> <td>21</td> <td>Reserved</td> </tr> <tr> <td>20</td> <td>48-BIT SUPPORTED bit</td> </tr> <tr> <td>19</td> <td>Reserved</td> </tr> <tr> <td>18</td> <td>SPIN-UP SUPPORTED bit</td> </tr> <tr> <td>17</td> <td>PUIS SUPPORTED bit</td> </tr> <tr> <td>16</td> <td>APM SUPPORTED bit</td> </tr> <tr> <td>15</td> <td>CFA SUPPORTED bit</td> </tr> <tr> <td>14</td> <td>DOWNLOAD MICROCODE SUPPORTED bit</td> </tr> <tr> <td>13</td> <td>UNLOAD SUPPORTED bit</td> </tr> <tr> <td>12</td> <td>The WRITE DMA FUA EXT and WRITE MULTIPLE FUA EXT commands are Supported</td> </tr> </tbody> </table> | Bit | Meaning | 63 | Set to one | 62:46 | Reserved | 45 | REQUEST SENSE DEVICE FAULT SUPPORTED bit | 44 | DSN SUPPORTED bit | 43 | LOW POWER STANDBY SUPPORTED bit | 42 | SET EPC POWER SOURCE SUPPORTED bit | 41 | AMAX ADDR SUPPORTED bit | 40 | Reserved for CFA | 39 | DRAT SUPPORTED bit | 38 | LPS MISALIGNMENT REPORTING SUPPORTED bit | 37 | Reserved | 36 | READ BUFFER DMA SUPPORTED bit | 35 | WRITE BUFFER DMA SUPPORTED bit | 34 | Reserved | 33 | DOWNLOAD MICROCODE DMA SUPPORTED bit | 32 | 28-BIT SUPPORTED bit | 31 | RZAT SUPPORTED bit | 30 | Reserved | 29 | NOP SUPPORTED bit | 28 | READ BUFFER SUPPORTED bit | 27 | WRITE BUFFER SUPPORTED bit | 26 | Reserved | 25 | READ LOOK-AHEAD SUPPORTED bit | 24 | VOLATILE WRITE CACHE SUPPORTED bit | 23 | SMART bit | 22 | FLUSH CACHE EXT SUPPORTED bit | 21 | Reserved | 20 | 48-BIT SUPPORTED bit | 19 | Reserved | 18 | SPIN-UP SUPPORTED bit | 17 | PUIS SUPPORTED bit | 16 | APM SUPPORTED bit | 15 | CFA SUPPORTED bit | 14 | DOWNLOAD MICROCODE SUPPORTED bit | 13 | UNLOAD SUPPORTED bit | 12 | The WRITE DMA FUA EXT and WRITE MULTIPLE FUA EXT commands are Supported |
| Bit | Meaning | | | | | | | | | | | | | | | | | | | | | | | | | | | | | | | | | | | | | | | | | | | | | | | | | | | | | | | | | | | | | | | | | | | | | | | | | | | |
| 63 | Set to one | | | | | | | | | | | | | | | | | | | | | | | | | | | | | | | | | | | | | | | | | | | | | | | | | | | | | | | | | | | | | | | | | | | | | | | | | | | |
| 62:46 | Reserved | | | | | | | | | | | | | | | | | | | | | | | | | | | | | | | | | | | | | | | | | | | | | | | | | | | | | | | | | | | | | | | | | | | | | | | | | | | |
| 45 | REQUEST SENSE DEVICE FAULT SUPPORTED bit | | | | | | | | | | | | | | | | | | | | | | | | | | | | | | | | | | | | | | | | | | | | | | | | | | | | | | | | | | | | | | | | | | | | | | | | | | | |
| 44 | DSN SUPPORTED bit | | | | | | | | | | | | | | | | | | | | | | | | | | | | | | | | | | | | | | | | | | | | | | | | | | | | | | | | | | | | | | | | | | | | | | | | | | | |
| 43 | LOW POWER STANDBY SUPPORTED bit | | | | | | | | | | | | | | | | | | | | | | | | | | | | | | | | | | | | | | | | | | | | | | | | | | | | | | | | | | | | | | | | | | | | | | | | | | | |
| 42 | SET EPC POWER SOURCE SUPPORTED bit | | | | | | | | | | | | | | | | | | | | | | | | | | | | | | | | | | | | | | | | | | | | | | | | | | | | | | | | | | | | | | | | | | | | | | | | | | | |
| 41 | AMAX ADDR SUPPORTED bit | | | | | | | | | | | | | | | | | | | | | | | | | | | | | | | | | | | | | | | | | | | | | | | | | | | | | | | | | | | | | | | | | | | | | | | | | | | |
| 40 | Reserved for CFA | | | | | | | | | | | | | | | | | | | | | | | | | | | | | | | | | | | | | | | | | | | | | | | | | | | | | | | | | | | | | | | | | | | | | | | | | | | |
| 39 | DRAT SUPPORTED bit | | | | | | | | | | | | | | | | | | | | | | | | | | | | | | | | | | | | | | | | | | | | | | | | | | | | | | | | | | | | | | | | | | | | | | | | | | | |
| 38 | LPS MISALIGNMENT REPORTING SUPPORTED bit | | | | | | | | | | | | | | | | | | | | | | | | | | | | | | | | | | | | | | | | | | | | | | | | | | | | | | | | | | | | | | | | | | | | | | | | | | | |
| 37 | Reserved | | | | | | | | | | | | | | | | | | | | | | | | | | | | | | | | | | | | | | | | | | | | | | | | | | | | | | | | | | | | | | | | | | | | | | | | | | | |
| 36 | READ BUFFER DMA SUPPORTED bit | | | | | | | | | | | | | | | | | | | | | | | | | | | | | | | | | | | | | | | | | | | | | | | | | | | | | | | | | | | | | | | | | | | | | | | | | | | |
| 35 | WRITE BUFFER DMA SUPPORTED bit | | | | | | | | | | | | | | | | | | | | | | | | | | | | | | | | | | | | | | | | | | | | | | | | | | | | | | | | | | | | | | | | | | | | | | | | | | | |
| 34 | Reserved | | | | | | | | | | | | | | | | | | | | | | | | | | | | | | | | | | | | | | | | | | | | | | | | | | | | | | | | | | | | | | | | | | | | | | | | | | | |
| 33 | DOWNLOAD MICROCODE DMA SUPPORTED bit | | | | | | | | | | | | | | | | | | | | | | | | | | | | | | | | | | | | | | | | | | | | | | | | | | | | | | | | | | | | | | | | | | | | | | | | | | | |
| 32 | 28-BIT SUPPORTED bit | | | | | | | | | | | | | | | | | | | | | | | | | | | | | | | | | | | | | | | | | | | | | | | | | | | | | | | | | | | | | | | | | | | | | | | | | | | |
| 31 | RZAT SUPPORTED bit | | | | | | | | | | | | | | | | | | | | | | | | | | | | | | | | | | | | | | | | | | | | | | | | | | | | | | | | | | | | | | | | | | | | | | | | | | | |
| 30 | Reserved | | | | | | | | | | | | | | | | | | | | | | | | | | | | | | | | | | | | | | | | | | | | | | | | | | | | | | | | | | | | | | | | | | | | | | | | | | | |
| 29 | NOP SUPPORTED bit | | | | | | | | | | | | | | | | | | | | | | | | | | | | | | | | | | | | | | | | | | | | | | | | | | | | | | | | | | | | | | | | | | | | | | | | | | | |
| 28 | READ BUFFER SUPPORTED bit | | | | | | | | | | | | | | | | | | | | | | | | | | | | | | | | | | | | | | | | | | | | | | | | | | | | | | | | | | | | | | | | | | | | | | | | | | | |
| 27 | WRITE BUFFER SUPPORTED bit | | | | | | | | | | | | | | | | | | | | | | | | | | | | | | | | | | | | | | | | | | | | | | | | | | | | | | | | | | | | | | | | | | | | | | | | | | | |
| 26 | Reserved | | | | | | | | | | | | | | | | | | | | | | | | | | | | | | | | | | | | | | | | | | | | | | | | | | | | | | | | | | | | | | | | | | | | | | | | | | | |
| 25 | READ LOOK-AHEAD SUPPORTED bit | | | | | | | | | | | | | | | | | | | | | | | | | | | | | | | | | | | | | | | | | | | | | | | | | | | | | | | | | | | | | | | | | | | | | | | | | | | |
| 24 | VOLATILE WRITE CACHE SUPPORTED bit | | | | | | | | | | | | | | | | | | | | | | | | | | | | | | | | | | | | | | | | | | | | | | | | | | | | | | | | | | | | | | | | | | | | | | | | | | | |
| 23 | SMART bit | | | | | | | | | | | | | | | | | | | | | | | | | | | | | | | | | | | | | | | | | | | | | | | | | | | | | | | | | | | | | | | | | | | | | | | | | | | |
| 22 | FLUSH CACHE EXT SUPPORTED bit | | | | | | | | | | | | | | | | | | | | | | | | | | | | | | | | | | | | | | | | | | | | | | | | | | | | | | | | | | | | | | | | | | | | | | | | | | | |
| 21 | Reserved | | | | | | | | | | | | | | | | | | | | | | | | | | | | | | | | | | | | | | | | | | | | | | | | | | | | | | | | | | | | | | | | | | | | | | | | | | | |
| 20 | 48-BIT SUPPORTED bit | | | | | | | | | | | | | | | | | | | | | | | | | | | | | | | | | | | | | | | | | | | | | | | | | | | | | | | | | | | | | | | | | | | | | | | | | | | |
| 19 | Reserved | | | | | | | | | | | | | | | | | | | | | | | | | | | | | | | | | | | | | | | | | | | | | | | | | | | | | | | | | | | | | | | | | | | | | | | | | | | |
| 18 | SPIN-UP SUPPORTED bit | | | | | | | | | | | | | | | | | | | | | | | | | | | | | | | | | | | | | | | | | | | | | | | | | | | | | | | | | | | | | | | | | | | | | | | | | | | |
| 17 | PUIS SUPPORTED bit | | | | | | | | | | | | | | | | | | | | | | | | | | | | | | | | | | | | | | | | | | | | | | | | | | | | | | | | | | | | | | | | | | | | | | | | | | | |
| 16 | APM SUPPORTED bit | | | | | | | | | | | | | | | | | | | | | | | | | | | | | | | | | | | | | | | | | | | | | | | | | | | | | | | | | | | | | | | | | | | | | | | | | | | |
| 15 | CFA SUPPORTED bit | | | | | | | | | | | | | | | | | | | | | | | | | | | | | | | | | | | | | | | | | | | | | | | | | | | | | | | | | | | | | | | | | | | | | | | | | | | |
| 14 | DOWNLOAD MICROCODE SUPPORTED bit | | | | | | | | | | | | | | | | | | | | | | | | | | | | | | | | | | | | | | | | | | | | | | | | | | | | | | | | | | | | | | | | | | | | | | | | | | | |
| 13 | UNLOAD SUPPORTED bit | | | | | | | | | | | | | | | | | | | | | | | | | | | | | | | | | | | | | | | | | | | | | | | | | | | | | | | | | | | | | | | | | | | | | | | | | | | |
| 12 | The WRITE DMA FUA EXT and WRITE MULTIPLE FUA EXT commands are Supported | | | | | | | | | | | | | | | | | | | | | | | | | | | | | | | | | | | | | | | | | | | | | | | | | | | | | | | | | | | | | | | | | | | | | | | | | | | |

Table 174 Supported Capabilities Log Page

| Offset | Type | Content | | | | | | | | | | | | | | |
|--------|------------------------------------|---|-----|---------|-----|---------------------------------|--------|----------|------|-----------------------------------|----|----------------------------|----|------------------------------------|-------|--------------------------------|
| 8..15 | QWord | Supported Capabilities | | | | | | | | | | | | | | |
| | | 11 GPL SUPPORTED bit 10 STREAMING SUPPORTED bit 9 Reserved 8 SMART SELF-TEST SUPPORTED bit 7 SMART ERROR LOGGING SUPPORTED bit 6 EPC SUPPORTED bit 5 SENSE DATA SUPPORTED bit 4 FREE-FALL SUPPORTED bit 3 DM MODE 3 SUPPORTED bit 2 GPL DMA SUPPORTED bit 1 WRITE UNCORRECTABLE SUPPORTED bit 0 WRV SUPPORTED bit | | | | | | | | | | | | | | |
| 16..23 | QWord | DOWNLOAD MICROCODE Capabilities | | | | | | | | | | | | | | |
| | | <table border="1"> <thead> <tr> <th>Bit</th> <th>Meaning</th> </tr> </thead> <tbody> <tr> <td>63</td> <td>Contents of the QWord are valid</td> </tr> <tr> <td>62:35</td> <td>Reserved</td> </tr> <tr> <td>34</td> <td>DM OFFSETS DEFERRED SUPPORTED bit</td> </tr> <tr> <td>33</td> <td>DM IMMEDIATE SUPPORTED bit</td> </tr> <tr> <td>32</td> <td>DM OFFSETS IMMEDIATE SUPPORTED bit</td> </tr> <tr> <td>31:16</td> <td>DM MAXIMUM TRANSFER SIZE field</td> </tr> <tr> <td>15:0</td> <td>DM MINIMUM TRANSFER SIZE field</td> </tr> </tbody> </table> | Bit | Meaning | 63 | Contents of the QWord are valid | 62:35 | Reserved | 34 | DM OFFSETS DEFERRED SUPPORTED bit | 33 | DM IMMEDIATE SUPPORTED bit | 32 | DM OFFSETS IMMEDIATE SUPPORTED bit | 31:16 | DM MAXIMUM TRANSFER SIZE field |
| Bit | Meaning | | | | | | | | | | | | | | | |
| 63 | Contents of the QWord are valid | | | | | | | | | | | | | | | |
| 62:35 | Reserved | | | | | | | | | | | | | | | |
| 34 | DM OFFSETS DEFERRED SUPPORTED bit | | | | | | | | | | | | | | | |
| 33 | DM IMMEDIATE SUPPORTED bit | | | | | | | | | | | | | | | |
| 32 | DM OFFSETS IMMEDIATE SUPPORTED bit | | | | | | | | | | | | | | | |
| 31:16 | DM MAXIMUM TRANSFER SIZE field | | | | | | | | | | | | | | | |
| 15:0 | DM MINIMUM TRANSFER SIZE field | | | | | | | | | | | | | | | |
| 24..31 | QWord | Nominal Media Rotation Rate | | | | | | | | | | | | | | |
| | | <table border="1"> <thead> <tr> <th>Bit</th> <th>Meaning</th> </tr> </thead> <tbody> <tr> <td>63</td> <td>Set to one</td> </tr> <tr> <td>62:16</td> <td>Reserved</td> </tr> <tr> <td>15:0</td> <td>NOMINAL MEDIA ROTATION RATE field</td> </tr> </tbody> </table> | Bit | Meaning | 63 | Set to one | 62:16 | Reserved | 15:0 | NOMINAL MEDIA ROTATION RATE field | | | | | | |
| Bit | Meaning | | | | | | | | | | | | | | | |
| 63 | Set to one | | | | | | | | | | | | | | | |
| 62:16 | Reserved | | | | | | | | | | | | | | | |
| 15:0 | NOMINAL MEDIA ROTATION RATE field | | | | | | | | | | | | | | | |
| 32..39 | QWord | Nominal Form Factor [was word 168] | | | | | | | | | | | | | | |
| | | <table border="1"> <thead> <tr> <th>Bit</th> <th>Meaning</th> </tr> </thead> <tbody> <tr> <td>63</td> <td>Contents of the QWord are valid</td> </tr> <tr> <td>62:4</td> <td>Reserved</td> </tr> <tr> <td>3:0</td> <td>Nominal Form Factor</td> </tr> </tbody> </table> | Bit | Meaning | 63 | Contents of the QWord are valid | 62:4 | Reserved | 3:0 | Nominal Form Factor | | | | | | |
| Bit | Meaning | | | | | | | | | | | | | | | |
| 63 | Contents of the QWord are valid | | | | | | | | | | | | | | | |
| 62:4 | Reserved | | | | | | | | | | | | | | | |
| 3:0 | Nominal Form Factor | | | | | | | | | | | | | | | |
| 40..47 | QWord | Write-Read-Verify Sector Count Mode 3 | | | | | | | | | | | | | | |
| | | <table border="1"> <thead> <tr> <th>Bit</th> <th>Meaning</th> </tr> </thead> <tbody> <tr> <td>63</td> <td>Contents of the QWord are valid</td> </tr> <tr> <td>62:32</td> <td>Reserved</td> </tr> <tr> <td>31:0</td> <td>WRV MODE 3 COUNT field</td> </tr> </tbody> </table> | Bit | Meaning | 63 | Contents of the QWord are valid | 62:32 | Reserved | 31:0 | WRV MODE 3 COUNT field | | | | | | |
| Bit | Meaning | | | | | | | | | | | | | | | |
| 63 | Contents of the QWord are valid | | | | | | | | | | | | | | | |
| 62:32 | Reserved | | | | | | | | | | | | | | | |
| 31:0 | WRV MODE 3 COUNT field | | | | | | | | | | | | | | | |
| 48..55 | QWord | Write-Read-Verify Sector Count Mode 2 | | | | | | | | | | | | | | |
| | | <table border="1"> <thead> <tr> <th>Bit</th> <th>Meaning</th> </tr> </thead> <tbody> <tr> <td>63</td> <td>Contents of the QWord are valid</td> </tr> <tr> <td>62:32</td> <td>Reserved</td> </tr> <tr> <td>31:0</td> <td>WRV MODE 2 COUNT field</td> </tr> </tbody> </table> | Bit | Meaning | 63 | Contents of the QWord are valid | 62:32 | Reserved | 31:0 | WRV MODE 2 COUNT field | | | | | | |
| Bit | Meaning | | | | | | | | | | | | | | | |
| 63 | Contents of the QWord are valid | | | | | | | | | | | | | | | |
| 62:32 | Reserved | | | | | | | | | | | | | | | |
| 31:0 | WRV MODE 2 COUNT field | | | | | | | | | | | | | | | |
| 56..71 | DQWord | World wide name [was word 108] | | | | | | | | | | | | | | |
| | | <table border="1"> <thead> <tr> <th>Bit</th> <th>Meaning</th> </tr> </thead> <tbody> <tr> <td>127</td> <td>Set to one</td> </tr> <tr> <td>126:64</td> <td>Reserved</td> </tr> <tr> <td>63:0</td> <td>World wide name</td> </tr> </tbody> </table> | Bit | Meaning | 127 | Set to one | 126:64 | Reserved | 63:0 | World wide name | | | | | | |
| Bit | Meaning | | | | | | | | | | | | | | | |
| 127 | Set to one | | | | | | | | | | | | | | | |
| 126:64 | Reserved | | | | | | | | | | | | | | | |
| 63:0 | World wide name | | | | | | | | | | | | | | | |

Table 175 Supported Capabilities Log Page - Continued -

| Offset | Type | Content |
|---------------------------------|-------|---------------------------|
| 72..79 | QWord | DATA SET MANAGEMENT |
| | | Bit Meaning |
| | | 63 Set to one |
| | | 62:1 Reserved |
| 0 TRIM SUPPORTED bit | | |
| 80..511 | | Reserved |

Table 176 Supported Capabilities Log Page - Continued -

11.23.10.5 Current Settings (page 04h)

The Current Settings log page provides a mechanism for the device to report the current settings for feature sets, features, and other device capabilities.

| Offset | Type | Content | | | | | | | | | | | | | | | | | | | | | | | | | | | | | | | | | | | | | | |
|--------|-----------------------------------|---|-----|---------|----|---------------------------------|-------|----------|-------|--------------------------|------|-------------------------------|-----|-----------------------|----|----------------------------------|----|------------------|----|-----------------------------------|----|------------------------|---|----------|---|------------------------------|---|-----------------------------|---|-------------------|---|----------|---|----------|---|------------------|---|-----------------|---|-----------------------|
| 0..7 | QWord | Supported Capabilities page information header. | | | | | | | | | | | | | | | | | | | | | | | | | | | | | | | | | | | | | | |
| | | <table border="1"> <thead> <tr> <th>Bit</th> <th>Meaning</th> </tr> </thead> <tbody> <tr> <td>63</td> <td>Set to one</td> </tr> <tr> <td>62:24</td> <td>Reserved</td> </tr> <tr> <td>23:16</td> <td>Page Number. Set to 04h.</td> </tr> <tr> <td>15:0</td> <td>Revision number. Set to 0001h</td> </tr> </tbody> </table> | Bit | Meaning | 63 | Set to one | 62:24 | Reserved | 23:16 | Page Number. Set to 04h. | 15:0 | Revision number. Set to 0001h | | | | | | | | | | | | | | | | | | | | | | | | | | | | |
| Bit | Meaning | | | | | | | | | | | | | | | | | | | | | | | | | | | | | | | | | | | | | | | |
| 63 | Set to one | | | | | | | | | | | | | | | | | | | | | | | | | | | | | | | | | | | | | | | |
| 62:24 | Reserved | | | | | | | | | | | | | | | | | | | | | | | | | | | | | | | | | | | | | | | |
| 23:16 | Page Number. Set to 04h. | | | | | | | | | | | | | | | | | | | | | | | | | | | | | | | | | | | | | | | |
| 15:0 | Revision number. Set to 0001h | | | | | | | | | | | | | | | | | | | | | | | | | | | | | | | | | | | | | | | |
| 8..15 | QWord | Current Settings | | | | | | | | | | | | | | | | | | | | | | | | | | | | | | | | | | | | | | |
| | | <table border="1"> <thead> <tr> <th>Bit</th> <th>Meaning</th> </tr> </thead> <tbody> <tr> <td>63</td> <td>Set to one</td> </tr> <tr> <td>62:17</td> <td>Reserved</td> </tr> <tr> <td>16</td> <td>DSN ENABLED bit</td> </tr> <tr> <td>15</td> <td>EPC ENABLED bit</td> </tr> <tr> <td>14</td> <td>8-BIT PIO ENABLED bit</td> </tr> <tr> <td>13</td> <td>VOLATILE WRITE CACHE ENABLED bit</td> </tr> <tr> <td>12</td> <td>Reserved for CFA</td> </tr> <tr> <td>11</td> <td>REVERTING TO DEFAULTS ENABLED bit</td> </tr> <tr> <td>10</td> <td>SENSE DATA ENABLED bit</td> </tr> <tr> <td>9</td> <td>Reserved</td> </tr> <tr> <td>8</td> <td>NON-VOLATILE WRITE CACHE bit</td> </tr> <tr> <td>7</td> <td>READ LOOK-AHEAD ENABLED bit</td> </tr> <tr> <td>6</td> <td>SMART ENABLED bit</td> </tr> <tr> <td>5</td> <td>Reserved</td> </tr> <tr> <td>4</td> <td>Reserved</td> </tr> <tr> <td>3</td> <td>PUIS ENABLED bit</td> </tr> <tr> <td>2</td> <td>APM ENABLED bit</td> </tr> <tr> <td>1</td> <td>FREE-FALL ENABLED bit</td> </tr> <tr> <td>0</td> <td>WRV ENABLED bit</td> </tr> </tbody> </table> | Bit | Meaning | 63 | Set to one | 62:17 | Reserved | 16 | DSN ENABLED bit | 15 | EPC ENABLED bit | 14 | 8-BIT PIO ENABLED bit | 13 | VOLATILE WRITE CACHE ENABLED bit | 12 | Reserved for CFA | 11 | REVERTING TO DEFAULTS ENABLED bit | 10 | SENSE DATA ENABLED bit | 9 | Reserved | 8 | NON-VOLATILE WRITE CACHE bit | 7 | READ LOOK-AHEAD ENABLED bit | 6 | SMART ENABLED bit | 5 | Reserved | 4 | Reserved | 3 | PUIS ENABLED bit | 2 | APM ENABLED bit | 1 | FREE-FALL ENABLED bit |
| Bit | Meaning | | | | | | | | | | | | | | | | | | | | | | | | | | | | | | | | | | | | | | | |
| 63 | Set to one | | | | | | | | | | | | | | | | | | | | | | | | | | | | | | | | | | | | | | | |
| 62:17 | Reserved | | | | | | | | | | | | | | | | | | | | | | | | | | | | | | | | | | | | | | | |
| 16 | DSN ENABLED bit | | | | | | | | | | | | | | | | | | | | | | | | | | | | | | | | | | | | | | | |
| 15 | EPC ENABLED bit | | | | | | | | | | | | | | | | | | | | | | | | | | | | | | | | | | | | | | | |
| 14 | 8-BIT PIO ENABLED bit | | | | | | | | | | | | | | | | | | | | | | | | | | | | | | | | | | | | | | | |
| 13 | VOLATILE WRITE CACHE ENABLED bit | | | | | | | | | | | | | | | | | | | | | | | | | | | | | | | | | | | | | | | |
| 12 | Reserved for CFA | | | | | | | | | | | | | | | | | | | | | | | | | | | | | | | | | | | | | | | |
| 11 | REVERTING TO DEFAULTS ENABLED bit | | | | | | | | | | | | | | | | | | | | | | | | | | | | | | | | | | | | | | | |
| 10 | SENSE DATA ENABLED bit | | | | | | | | | | | | | | | | | | | | | | | | | | | | | | | | | | | | | | | |
| 9 | Reserved | | | | | | | | | | | | | | | | | | | | | | | | | | | | | | | | | | | | | | | |
| 8 | NON-VOLATILE WRITE CACHE bit | | | | | | | | | | | | | | | | | | | | | | | | | | | | | | | | | | | | | | | |
| 7 | READ LOOK-AHEAD ENABLED bit | | | | | | | | | | | | | | | | | | | | | | | | | | | | | | | | | | | | | | | |
| 6 | SMART ENABLED bit | | | | | | | | | | | | | | | | | | | | | | | | | | | | | | | | | | | | | | | |
| 5 | Reserved | | | | | | | | | | | | | | | | | | | | | | | | | | | | | | | | | | | | | | | |
| 4 | Reserved | | | | | | | | | | | | | | | | | | | | | | | | | | | | | | | | | | | | | | | |
| 3 | PUIS ENABLED bit | | | | | | | | | | | | | | | | | | | | | | | | | | | | | | | | | | | | | | | |
| 2 | APM ENABLED bit | | | | | | | | | | | | | | | | | | | | | | | | | | | | | | | | | | | | | | | |
| 1 | FREE-FALL ENABLED bit | | | | | | | | | | | | | | | | | | | | | | | | | | | | | | | | | | | | | | | |
| 0 | WRV ENABLED bit | | | | | | | | | | | | | | | | | | | | | | | | | | | | | | | | | | | | | | | |
| 16..23 | QWord | Feature Settings | | | | | | | | | | | | | | | | | | | | | | | | | | | | | | | | | | | | | | |
| | | <table border="1"> <thead> <tr> <th>Bit</th> <th>Meaning</th> </tr> </thead> <tbody> <tr> <td>63</td> <td>Contents of the QWord are valid</td> </tr> <tr> <td>62:16</td> <td>Reserved</td> </tr> <tr> <td>17:16</td> <td>POWER SOURCE field</td> </tr> <tr> <td>15:8</td> <td>APM LEVEL field</td> </tr> <tr> <td>7:0</td> <td>WRV MODE field</td> </tr> </tbody> </table> | Bit | Meaning | 63 | Contents of the QWord are valid | 62:16 | Reserved | 17:16 | POWER SOURCE field | 15:8 | APM LEVEL field | 7:0 | WRV MODE field | | | | | | | | | | | | | | | | | | | | | | | | | | |
| Bit | Meaning | | | | | | | | | | | | | | | | | | | | | | | | | | | | | | | | | | | | | | | |
| 63 | Contents of the QWord are valid | | | | | | | | | | | | | | | | | | | | | | | | | | | | | | | | | | | | | | | |
| 62:16 | Reserved | | | | | | | | | | | | | | | | | | | | | | | | | | | | | | | | | | | | | | | |
| 17:16 | POWER SOURCE field | | | | | | | | | | | | | | | | | | | | | | | | | | | | | | | | | | | | | | | |
| 15:8 | APM LEVEL field | | | | | | | | | | | | | | | | | | | | | | | | | | | | | | | | | | | | | | | |
| 7:0 | WRV MODE field | | | | | | | | | | | | | | | | | | | | | | | | | | | | | | | | | | | | | | | |
| 24..31 | QWord | DMA Host Interface Sector Times | | | | | | | | | | | | | | | | | | | | | | | | | | | | | | | | | | | | | | |
| | | <table border="1"> <thead> <tr> <th>Bit</th> <th>Meaning</th> </tr> </thead> <tbody> <tr> <td>63</td> <td>Contents of the QWord are valid</td> </tr> <tr> <td>62:16</td> <td>Reserved</td> </tr> <tr> <td>15:0</td> <td>DMA SECTOR TIME field</td> </tr> </tbody> </table> | Bit | Meaning | 63 | Contents of the QWord are valid | 62:16 | Reserved | 15:0 | DMA SECTOR TIME field | | | | | | | | | | | | | | | | | | | | | | | | | | | | | | |
| Bit | Meaning | | | | | | | | | | | | | | | | | | | | | | | | | | | | | | | | | | | | | | | |
| 63 | Contents of the QWord are valid | | | | | | | | | | | | | | | | | | | | | | | | | | | | | | | | | | | | | | | |
| 62:16 | Reserved | | | | | | | | | | | | | | | | | | | | | | | | | | | | | | | | | | | | | | | |
| 15:0 | DMA SECTOR TIME field | | | | | | | | | | | | | | | | | | | | | | | | | | | | | | | | | | | | | | | |
| 32..39 | QWord | PIO Host Interface Sector Times | | | | | | | | | | | | | | | | | | | | | | | | | | | | | | | | | | | | | | |
| | | <table border="1"> <thead> <tr> <th>Bit</th> <th>Meaning</th> </tr> </thead> <tbody> <tr> <td>63</td> <td>Contents of the QWord are valid</td> </tr> <tr> <td>62:16</td> <td>Reserved</td> </tr> <tr> <td>15:0</td> <td>PIO SECTOR TIME field</td> </tr> </tbody> </table> | Bit | Meaning | 63 | Contents of the QWord are valid | 62:16 | Reserved | 15:0 | PIO SECTOR TIME field | | | | | | | | | | | | | | | | | | | | | | | | | | | | | | |
| Bit | Meaning | | | | | | | | | | | | | | | | | | | | | | | | | | | | | | | | | | | | | | | |
| 63 | Contents of the QWord are valid | | | | | | | | | | | | | | | | | | | | | | | | | | | | | | | | | | | | | | | |
| 62:16 | Reserved | | | | | | | | | | | | | | | | | | | | | | | | | | | | | | | | | | | | | | | |
| 15:0 | PIO SECTOR TIME field | | | | | | | | | | | | | | | | | | | | | | | | | | | | | | | | | | | | | | | |

Table 177 Current Settings Log Page

| Offset | Type | Content | | | | | | | | | | |
|---------|---------------------------------------|--|-----|---------|----|---------------------------------|-------|----------|-------|---------------------------------------|-------|---------------------------------|
| 40..47 | QWord | Streaming minimum request size | | | | | | | | | | |
| | | <table border="0"> <thead> <tr> <th>Bit</th> <th>Meaning</th> </tr> </thead> <tbody> <tr> <td>63</td> <td>Contents of the QWord are valid</td> </tr> <tr> <td>62:16</td> <td>Reserved</td> </tr> <tr> <td>15:0</td> <td>STREAM MIN REQUEST SIZE field</td> </tr> </tbody> </table> | Bit | Meaning | 63 | Contents of the QWord are valid | 62:16 | Reserved | 15:0 | STREAM MIN REQUEST SIZE field | | |
| Bit | Meaning | | | | | | | | | | | |
| 63 | Contents of the QWord are valid | | | | | | | | | | | |
| 62:16 | Reserved | | | | | | | | | | | |
| 15:0 | STREAM MIN REQUEST SIZE field | | | | | | | | | | | |
| 48..55 | QWord | Streaming access latency | | | | | | | | | | |
| | | <table border="0"> <thead> <tr> <th>Bit</th> <th>Meaning</th> </tr> </thead> <tbody> <tr> <td>63</td> <td>Contents of the QWord are valid</td> </tr> <tr> <td>62:16</td> <td>Reserved</td> </tr> <tr> <td>15:0</td> <td>STREAM ACCESS LATENCY field</td> </tr> </tbody> </table> | Bit | Meaning | 63 | Contents of the QWord are valid | 62:16 | Reserved | 15:0 | STREAM ACCESS LATENCY field | | |
| Bit | Meaning | | | | | | | | | | | |
| 63 | Contents of the QWord are valid | | | | | | | | | | | |
| 62:16 | Reserved | | | | | | | | | | | |
| 15:0 | STREAM ACCESS LATENCY field | | | | | | | | | | | |
| 56..63 | QWord | Streaming Performance Granularity | | | | | | | | | | |
| | | <table border="0"> <thead> <tr> <th>Bit</th> <th>Meaning</th> </tr> </thead> <tbody> <tr> <td>63</td> <td>Contents of the QWord are valid</td> </tr> <tr> <td>62:32</td> <td>Reserved</td> </tr> <tr> <td>31:0</td> <td>STREAM GRANULARITY field</td> </tr> </tbody> </table> | Bit | Meaning | 63 | Contents of the QWord are valid | 62:32 | Reserved | 31:0 | STREAM GRANULARITY field | | |
| Bit | Meaning | | | | | | | | | | | |
| 63 | Contents of the QWord are valid | | | | | | | | | | | |
| 62:32 | Reserved | | | | | | | | | | | |
| 31:0 | STREAM GRANULARITY field | | | | | | | | | | | |
| 64..71 | QWord | Free-fall Control Sensitivity | | | | | | | | | | |
| | | <table border="0"> <thead> <tr> <th>Bit</th> <th>Meaning</th> </tr> </thead> <tbody> <tr> <td>63</td> <td>Contents of the QWord are valid</td> </tr> <tr> <td>62:16</td> <td>Reserved</td> </tr> <tr> <td>7:0</td> <td>FREE-FALL SENSITIVITY field</td> </tr> </tbody> </table> | Bit | Meaning | 63 | Contents of the QWord are valid | 62:16 | Reserved | 7:0 | FREE-FALL SENSITIVITY field | | |
| Bit | Meaning | | | | | | | | | | | |
| 63 | Contents of the QWord are valid | | | | | | | | | | | |
| 62:16 | Reserved | | | | | | | | | | | |
| 7:0 | FREE-FALL SENSITIVITY field | | | | | | | | | | | |
| 72..79 | QWord | Device Maintenance Schedule | | | | | | | | | | |
| | | <table border="0"> <thead> <tr> <th>Bit</th> <th>Meaning</th> </tr> </thead> <tbody> <tr> <td>63</td> <td>Contents of the QWord are valid</td> </tr> <tr> <td>62:48</td> <td>Reserved</td> </tr> <tr> <td>47:32</td> <td>Time scheduled for device maintenance</td> </tr> <tr> <td>31:16</td> <td>Time to performance degradation</td> </tr> <tr> <td>15:0</td> <td>Minimum inactive time</td> </tr> </tbody> </table> | Bit | Meaning | 63 | Contents of the QWord are valid | 62:48 | Reserved | 47:32 | Time scheduled for device maintenance | 31:16 | Time to performance degradation |
| Bit | Meaning | | | | | | | | | | | |
| 63 | Contents of the QWord are valid | | | | | | | | | | | |
| 62:48 | Reserved | | | | | | | | | | | |
| 47:32 | Time scheduled for device maintenance | | | | | | | | | | | |
| 31:16 | Time to performance degradation | | | | | | | | | | | |
| 15:0 | Minimum inactive time | | | | | | | | | | | |
| 80..511 | | Reserved | | | | | | | | | | |

Table 178 Current Settings Log Page - Continued -

11.23.10.6 Strings (page 05h)

The Strings log page provides a mechanism for the device to report ATA String based information.

| Offset | Type | Content | | | | | | | | |
|----------|-------------------------------|--|-----|---------|----|------------|-------|----------|-------|-------------------------|
| 0..7 | QWord | Strings page information header. | | | | | | | | |
| | | <table border="0"> <thead> <tr> <th>Bit</th> <th>Meaning</th> </tr> </thead> <tbody> <tr> <td>63</td> <td>Set to one</td> </tr> <tr> <td>62:24</td> <td>Reserved</td> </tr> <tr> <td>23:16</td> <td>Page Number. Set to 05h</td> </tr> <tr> <td>15:0</td> <td>Revision number. Set to 0001h</td> </tr> </tbody> </table> | Bit | Meaning | 63 | Set to one | 62:24 | Reserved | 23:16 | Page Number. Set to 05h |
| Bit | Meaning | | | | | | | | | |
| 63 | Set to one | | | | | | | | | |
| 62:24 | Reserved | | | | | | | | | |
| 23:16 | Page Number. Set to 05h | | | | | | | | | |
| 15:0 | Revision number. Set to 0001h | | | | | | | | | |
| 8..27 | ATA String | Serial number | | | | | | | | |
| 28..31 | | Reserved | | | | | | | | |
| 32..39 | ATA String | Firmware revision | | | | | | | | |
| 40..47 | | Reserved | | | | | | | | |
| 48..87 | ATA String | Model number | | | | | | | | |
| 88..95 | | Reserved | | | | | | | | |
| 96..103 | ATA String | Additional Product Identifier | | | | | | | | |
| 104..511 | | Reserved | | | | | | | | |

Table 179 Strings Log Page

11.23.10.7 Security (page 06h)

The Security log page provides a mechanism for the device to report Security based information.

| Offset | Type | Content | | | | | | | | | | | | | | | | | | |
|--------|--|--|-----|---------|----|----------------------------------|-------|----------|-------|--|------|--|---|--|---|----------------------------|---|-------------------------|---|-------------------------------|
| 0..7 | QWord | Security page information header. | | | | | | | | | | | | | | | | | | |
| | | <table border="0"> <thead> <tr> <th>Bit</th> <th>Meaning</th> </tr> </thead> <tbody> <tr> <td>63</td> <td>Set to one</td> </tr> <tr> <td>62:24</td> <td>Reserved</td> </tr> <tr> <td>23:16</td> <td>Page Number. Set to 06h.</td> </tr> <tr> <td>15:0</td> <td>Revision number. Set to 0001h</td> </tr> </tbody> </table> | Bit | Meaning | 63 | Set to one | 62:24 | Reserved | 23:16 | Page Number. Set to 06h. | 15:0 | Revision number. Set to 0001h | | | | | | | | |
| Bit | Meaning | | | | | | | | | | | | | | | | | | | |
| 63 | Set to one | | | | | | | | | | | | | | | | | | | |
| 62:24 | Reserved | | | | | | | | | | | | | | | | | | | |
| 23:16 | Page Number. Set to 06h. | | | | | | | | | | | | | | | | | | | |
| 15:0 | Revision number. Set to 0001h | | | | | | | | | | | | | | | | | | | |
| 8..15 | QWord | Master Password Identifier [was word 92] | | | | | | | | | | | | | | | | | | |
| | | <table border="0"> <thead> <tr> <th>Bit</th> <th>Meaning</th> </tr> </thead> <tbody> <tr> <td>63</td> <td>Contents of the QWord are valid.</td> </tr> <tr> <td>62:16</td> <td>Reserved</td> </tr> <tr> <td>15:0</td> <td>Master Password Identifier</td> </tr> </tbody> </table> | Bit | Meaning | 63 | Contents of the QWord are valid. | 62:16 | Reserved | 15:0 | Master Password Identifier | | | | | | | | | | |
| Bit | Meaning | | | | | | | | | | | | | | | | | | | |
| 63 | Contents of the QWord are valid. | | | | | | | | | | | | | | | | | | | |
| 62:16 | Reserved | | | | | | | | | | | | | | | | | | | |
| 15:0 | Master Password Identifier | | | | | | | | | | | | | | | | | | | |
| 16..23 | QWord | Security Status | | | | | | | | | | | | | | | | | | |
| | | <table border="0"> <thead> <tr> <th>Bit</th> <th>Meaning</th> </tr> </thead> <tbody> <tr> <td>63</td> <td>Contents of the QWord are valid</td> </tr> <tr> <td>62:7</td> <td>Reserved</td> </tr> <tr> <td>6</td> <td>SECURITY SUPPORTED bit</td> </tr> <tr> <td>5</td> <td>MASTER PASSWORD CAPABILITY bit</td> </tr> <tr> <td>4</td> <td>ENHANCED SECURITY ERASE SUPPORTED bit</td> </tr> <tr> <td>3</td> <td>SECURITY COUNT EXPIRED bit</td> </tr> <tr> <td>2</td> <td>SECURITY FROZEN bit</td> </tr> <tr> <td>1</td> <td>SECURITY LOCKED bit</td> </tr> <tr> <td>0</td> <td>SECURITY ENABLED bit</td> </tr> </tbody> </table> | Bit | Meaning | 63 | Contents of the QWord are valid | 62:7 | Reserved | 6 | SECURITY SUPPORTED bit | 5 | MASTER PASSWORD CAPABILITY bit | 4 | ENHANCED SECURITY ERASE SUPPORTED bit | 3 | SECURITY COUNT EXPIRED bit | 2 | SECURITY FROZEN bit | 1 | SECURITY LOCKED bit |
| Bit | Meaning | | | | | | | | | | | | | | | | | | | |
| 63 | Contents of the QWord are valid | | | | | | | | | | | | | | | | | | | |
| 62:7 | Reserved | | | | | | | | | | | | | | | | | | | |
| 6 | SECURITY SUPPORTED bit | | | | | | | | | | | | | | | | | | | |
| 5 | MASTER PASSWORD CAPABILITY bit | | | | | | | | | | | | | | | | | | | |
| 4 | ENHANCED SECURITY ERASE SUPPORTED bit | | | | | | | | | | | | | | | | | | | |
| 3 | SECURITY COUNT EXPIRED bit | | | | | | | | | | | | | | | | | | | |
| 2 | SECURITY FROZEN bit | | | | | | | | | | | | | | | | | | | |
| 1 | SECURITY LOCKED bit | | | | | | | | | | | | | | | | | | | |
| 0 | SECURITY ENABLED bit | | | | | | | | | | | | | | | | | | | |
| 24..31 | QWord | Time required for an Enhanced Erase mode SECURITY ERASE UNIT command [was word 90] | | | | | | | | | | | | | | | | | | |
| | | <table border="0"> <thead> <tr> <th>Bit</th> <th>Meaning</th> </tr> </thead> <tbody> <tr> <td>63</td> <td>Contents of the QWord are valid</td> </tr> <tr> <td>62:15</td> <td>Reserved</td> </tr> <tr> <td>14:0</td> <td>ENHANCED SECURITY ERASE TIME field</td> </tr> </tbody> </table> | Bit | Meaning | 63 | Contents of the QWord are valid | 62:15 | Reserved | 14:0 | ENHANCED SECURITY ERASE TIME field | | | | | | | | | | |
| Bit | Meaning | | | | | | | | | | | | | | | | | | | |
| 63 | Contents of the QWord are valid | | | | | | | | | | | | | | | | | | | |
| 62:15 | Reserved | | | | | | | | | | | | | | | | | | | |
| 14:0 | ENHANCED SECURITY ERASE TIME field | | | | | | | | | | | | | | | | | | | |
| 32..39 | QWord | Time required for a Normal Erase mode SECURITY ERASE UNIT command [was word 89] | | | | | | | | | | | | | | | | | | |
| | | <table border="0"> <thead> <tr> <th>Bit</th> <th>Meaning</th> </tr> </thead> <tbody> <tr> <td>63</td> <td>Contents of the QWord are valid</td> </tr> <tr> <td>62:15</td> <td>Reserved</td> </tr> <tr> <td>14:0</td> <td>NORMAL SECURITY ERASE TIME field</td> </tr> </tbody> </table> | Bit | Meaning | 63 | Contents of the QWord are valid | 62:15 | Reserved | 14:0 | NORMAL SECURITY ERASE TIME field | | | | | | | | | | |
| Bit | Meaning | | | | | | | | | | | | | | | | | | | |
| 63 | Contents of the QWord are valid | | | | | | | | | | | | | | | | | | | |
| 62:15 | Reserved | | | | | | | | | | | | | | | | | | | |
| 14:0 | NORMAL SECURITY ERASE TIME field | | | | | | | | | | | | | | | | | | | |
| 40..47 | QWord | Trusted Computing feature set | | | | | | | | | | | | | | | | | | |
| | | <table border="0"> <thead> <tr> <th>Bit</th> <th>Meaning</th> </tr> </thead> <tbody> <tr> <td>63</td> <td>Contents of the QWord are valid</td> </tr> <tr> <td>62:1</td> <td>Reserved</td> </tr> <tr> <td>0</td> <td>TRUSTED COMPUTING SUPPORTED bit</td> </tr> </tbody> </table> | Bit | Meaning | 63 | Contents of the QWord are valid | 62:1 | Reserved | 0 | TRUSTED COMPUTING SUPPORTED bit | | | | | | | | | | |
| Bit | Meaning | | | | | | | | | | | | | | | | | | | |
| 63 | Contents of the QWord are valid | | | | | | | | | | | | | | | | | | | |
| 62:1 | Reserved | | | | | | | | | | | | | | | | | | | |
| 0 | TRUSTED COMPUTING SUPPORTED bit | | | | | | | | | | | | | | | | | | | |
| 48..55 | QWord | Security Capabilities | | | | | | | | | | | | | | | | | | |
| | | <table border="0"> <thead> <tr> <th>Bit</th> <th>Meaning</th> </tr> </thead> <tbody> <tr> <td>63</td> <td>Contents of the QWord are valid</td> </tr> <tr> <td>62:8</td> <td>Reserved</td> </tr> <tr> <td>7</td> <td>RESTRICTED SANITIZE OVERRIDES SECURITY bit</td> </tr> <tr> <td>6</td> <td>ACS-3 COMMANDS ALLOWED BY SANITIZE bit</td> </tr> <tr> <td>5</td> <td>SANITIZE ANTIFREEZE LOCK SUPPORTED bit</td> </tr> <tr> <td>4</td> <td>BLOCK ERASE SUPPORTED bit</td> </tr> <tr> <td>3</td> <td>OVERWRITE SUPPORTED bit</td> </tr> <tr> <td>2</td> <td>CRYPTO SCRAMBLE SUPPORTED bit</td> </tr> <tr> <td>1</td> <td>SANITIZE SUPPORTED bit</td> </tr> </tbody> </table> | Bit | Meaning | 63 | Contents of the QWord are valid | 62:8 | Reserved | 7 | RESTRICTED SANITIZE OVERRIDES SECURITY bit | 6 | ACS-3 COMMANDS ALLOWED BY SANITIZE bit | 5 | SANITIZE ANTIFREEZE LOCK SUPPORTED bit | 4 | BLOCK ERASE SUPPORTED bit | 3 | OVERWRITE SUPPORTED bit | 2 | CRYPTO SCRAMBLE SUPPORTED bit |
| Bit | Meaning | | | | | | | | | | | | | | | | | | | |
| 63 | Contents of the QWord are valid | | | | | | | | | | | | | | | | | | | |
| 62:8 | Reserved | | | | | | | | | | | | | | | | | | | |
| 7 | RESTRICTED SANITIZE OVERRIDES SECURITY bit | | | | | | | | | | | | | | | | | | | |
| 6 | ACS-3 COMMANDS ALLOWED BY SANITIZE bit | | | | | | | | | | | | | | | | | | | |
| 5 | SANITIZE ANTIFREEZE LOCK SUPPORTED bit | | | | | | | | | | | | | | | | | | | |
| 4 | BLOCK ERASE SUPPORTED bit | | | | | | | | | | | | | | | | | | | |
| 3 | OVERWRITE SUPPORTED bit | | | | | | | | | | | | | | | | | | | |
| 2 | CRYPTO SCRAMBLE SUPPORTED bit | | | | | | | | | | | | | | | | | | | |
| 1 | SANITIZE SUPPORTED bit | | | | | | | | | | | | | | | | | | | |

| | | | |
|---------|--|---|---------------------------|
| | | 0 | ENCRYPT ALL SUPPORTED bit |
| 56..511 | | | Reserved |

Table 180 Security Log Page

11.23.10.8 Parallel ATA (page 07h)

The Parallel ATA log page provides information about the Parallel ATA Transport. This page is not supported.

11.23.10.9 Serial ATA (page 08h)

The Serial ATA log page provides information about the Serial ATA Transport.

| Offset | Type | Content |
|---|-------|---|
| 0..7 | QWord | Serial ATA page information header. |
| | | Bit Meaning |
| | | 63 Set to one |
| | | 62:24 Reserved |
| | | 23:16 Page Number. Set to 08h. 15:0 Revision number. Set to 0001h |
| 8..15 | QWord | SATA Capabilities |
| | | Bit Meaning |
| | | 63 Set to one |
| | | 62:29 Reserved for Serial ATA |
| | | 28 DIPM SSP PRESERVATION SUPPORTED |
| | | 27 Reserved |
| | | 26 DEVSLEEP_TO_REDUCEDPWRSTATE CAPABILITY SUPPORTED |
| | | 25 DEVICE SLEEP SUPPORTED |
| | | 24 NCQ AUTOSENSE SUPPORTED bit |
| | | 23 SOFTWARE SETTINGS PRESERVATION SUPPORTED bit |
| | | 22 HARDWARE FEATURE CONTROL SUPPORTED bit |
| | | 21 IN-ORDER DATA DELIVERY SUPPORTED bit |
| | | 20 DEVICE INITIATED POWER MANAGEMENT SUPPORTED bit |
| | | 19 DMA SETUP AUTO-ACTIVATION SUPPORTED bit |
| | | 18 NON-ZERO BUFFER OFFSETS SUPPORTED bit |
| | | 17 SEND AND RECEIVE QUEUED COMMANDS SUPPORTED bit |
| | | 16 NCQ NON-DATA COMMAND SUPPORTED bit |
| | | 15 NCQ STREAMING SUPPORTED bit |
| | | 14 READ LOG DMA EXT AS EQUIVALENT TO READ LOG EXT SUPPORTED bit |
| | | 13 DEVICE AUTOMATIC PARTIAL TO SLUMBER TRANSITIONS SUPPORTED bit |
| | | 12 HOST AUTOMATIC PARTIAL TO SLUMBER TRANSITIONS SUPPORTED bit |
| | | 11 NCQ PRIORITY INFORMATION SUPPORTED bit |
| | | 10 UNLOAD WHILE NCQ COMMANDS ARE OUTSTANDING SUPPORTED bit |
| | | 9 SATA PHY EVENT COUNTERS LOG SUPPORTED bit |
| | | 8 RECEIPT OF HOST INITIATED POWER MANAGEMENT REQUESTS SUPPORTED bit |
| | | 7 NCQ FEATURE SET SUPPORTED bit |
| | | 6:3 Reserved |
| 2 SATA GEN3 SIGNALING SPEED SUPPORTED bit | | |
| 1 SATA GEN2 SIGNALING SPEED SUPPORTED bit | | |
| 0 SATA GEN1 SIGNALING SPEED SUPPORTED bit | | |

Table 181 Serial ATA Log Page

| Offset | Type | Content | | | | | | | | | | | | | | | | | | | | | | | | | | | | | | |
|--------|--|---|-----|---------|----|------------------|-------|----------|-------|------------------------------|-------|--|-------|--|-------|---|-------|------------------------------------|-------|--|-------|---------------------------------------|-------|-------------------------------------|-------|---------------------------------------|------|--------------------------------|-----|-------------------------------|-----|---------------------------------|
| 16..23 | QWord | Current SATA Settings | | | | | | | | | | | | | | | | | | | | | | | | | | | | | | |
| | | <table border="1"> <thead> <tr> <th>Bit</th> <th>Meaning</th> </tr> </thead> <tbody> <tr> <td>63</td> <td>Set to one</td> </tr> <tr> <td>62:11</td> <td>Reserved</td> </tr> <tr> <td>10</td> <td>DEVICE SLEEP ENABLED bit</td> </tr> <tr> <td>9</td> <td>AUTOMATIC PARTIAL TO SLUMBER TRANSITIONS ENABLED bit</td> </tr> <tr> <td>8</td> <td>SOFTWARE SETTINGS PRESERVATION ENABLED bit</td> </tr> <tr> <td>7</td> <td>HARDWARE FEATURE CONTROL IS ENABLED bit</td> </tr> <tr> <td>6</td> <td>IN-ORDER DATA DELIVERY ENABLED bit</td> </tr> <tr> <td>5</td> <td>DEVICE INITIATED POWER MANAGEMENT ENABLED bit)</td> </tr> <tr> <td>4</td> <td>DMA SETUP AUTO-ACTIVATION ENABLED bit</td> </tr> <tr> <td>3</td> <td>NON-ZERO BUFFER OFFSETS ENABLED bit</td> </tr> <tr> <td>2:0</td> <td>CURRENT SERIAL ATA SIGNAL SPEED field</td> </tr> </tbody> </table> | Bit | Meaning | 63 | Set to one | 62:11 | Reserved | 10 | DEVICE SLEEP ENABLED bit | 9 | AUTOMATIC PARTIAL TO SLUMBER TRANSITIONS ENABLED bit | 8 | SOFTWARE SETTINGS PRESERVATION ENABLED bit | 7 | HARDWARE FEATURE CONTROL IS ENABLED bit | 6 | IN-ORDER DATA DELIVERY ENABLED bit | 5 | DEVICE INITIATED POWER MANAGEMENT ENABLED bit) | 4 | DMA SETUP AUTO-ACTIVATION ENABLED bit | 3 | NON-ZERO BUFFER OFFSETS ENABLED bit | 2:0 | CURRENT SERIAL ATA SIGNAL SPEED field | | | | | | |
| Bit | Meaning | | | | | | | | | | | | | | | | | | | | | | | | | | | | | | | |
| 63 | Set to one | | | | | | | | | | | | | | | | | | | | | | | | | | | | | | | |
| 62:11 | Reserved | | | | | | | | | | | | | | | | | | | | | | | | | | | | | | | |
| 10 | DEVICE SLEEP ENABLED bit | | | | | | | | | | | | | | | | | | | | | | | | | | | | | | | |
| 9 | AUTOMATIC PARTIAL TO SLUMBER TRANSITIONS ENABLED bit | | | | | | | | | | | | | | | | | | | | | | | | | | | | | | | |
| 8 | SOFTWARE SETTINGS PRESERVATION ENABLED bit | | | | | | | | | | | | | | | | | | | | | | | | | | | | | | | |
| 7 | HARDWARE FEATURE CONTROL IS ENABLED bit | | | | | | | | | | | | | | | | | | | | | | | | | | | | | | | |
| 6 | IN-ORDER DATA DELIVERY ENABLED bit | | | | | | | | | | | | | | | | | | | | | | | | | | | | | | | |
| 5 | DEVICE INITIATED POWER MANAGEMENT ENABLED bit) | | | | | | | | | | | | | | | | | | | | | | | | | | | | | | | |
| 4 | DMA SETUP AUTO-ACTIVATION ENABLED bit | | | | | | | | | | | | | | | | | | | | | | | | | | | | | | | |
| 3 | NON-ZERO BUFFER OFFSETS ENABLED bit | | | | | | | | | | | | | | | | | | | | | | | | | | | | | | | |
| 2:0 | CURRENT SERIAL ATA SIGNAL SPEED field | | | | | | | | | | | | | | | | | | | | | | | | | | | | | | | |
| 24..39 | | Reserved | | | | | | | | | | | | | | | | | | | | | | | | | | | | | | |
| 40..41 | Word | CURRENT HARDWARE FEATURE CONTROL IDENTIFIER field | | | | | | | | | | | | | | | | | | | | | | | | | | | | | | |
| 42..43 | Word | SUPPORTED HARDWARE FEATURE CONTROL IDENTIFIER field | | | | | | | | | | | | | | | | | | | | | | | | | | | | | | |
| 44..47 | | Reserved | | | | | | | | | | | | | | | | | | | | | | | | | | | | | | |
| 48..55 | QWord | DEVSLP TIMING VARIABLES | | | | | | | | | | | | | | | | | | | | | | | | | | | | | | |
| | | <table border="1"> <thead> <tr> <th>Bit</th> <th>Meaning</th> </tr> </thead> <tbody> <tr> <td>63</td> <td>DEVSLP SUPPORTED</td> </tr> <tr> <td>62:16</td> <td>Reserved</td> </tr> <tr> <td>15:8</td> <td>DEVSLEEP EXIT TIMEOUT (DETO)</td> </tr> <tr> <td>7:5</td> <td>Reserved</td> </tr> <tr> <td>4:0</td> <td>MINIMUM DEVSLP ASSERTION TIME (MDAT)</td> </tr> </tbody> </table> | Bit | Meaning | 63 | DEVSLP SUPPORTED | 62:16 | Reserved | 15:8 | DEVSLEEP EXIT TIMEOUT (DETO) | 7:5 | Reserved | 4:0 | MINIMUM DEVSLP ASSERTION TIME (MDAT) | | | | | | | | | | | | | | | | | | |
| Bit | Meaning | | | | | | | | | | | | | | | | | | | | | | | | | | | | | | | |
| 63 | DEVSLP SUPPORTED | | | | | | | | | | | | | | | | | | | | | | | | | | | | | | | |
| 62:16 | Reserved | | | | | | | | | | | | | | | | | | | | | | | | | | | | | | | |
| 15:8 | DEVSLEEP EXIT TIMEOUT (DETO) | | | | | | | | | | | | | | | | | | | | | | | | | | | | | | | |
| 7:5 | Reserved | | | | | | | | | | | | | | | | | | | | | | | | | | | | | | | |
| 4:0 | MINIMUM DEVSLP ASSERTION TIME (MDAT) | | | | | | | | | | | | | | | | | | | | | | | | | | | | | | | |
| 56..63 | QWord | TRANSITIONAL ENERGY REPORTING | | | | | | | | | | | | | | | | | | | | | | | | | | | | | | |
| | | <table border="1"> <thead> <tr> <th>Bit</th> <th>Meaning</th> </tr> </thead> <tbody> <tr> <td>63</td> <td>TER SUPPORTED</td> </tr> <tr> <td>62:55</td> <td>Reserved</td> </tr> <tr> <td>54:53</td> <td>IN-STATE DEVSLEEP POWER UNIT</td> </tr> <tr> <td>52:48</td> <td>TYPICAL IN-STATE DEVSLEEP POWER</td> </tr> <tr> <td>47:46</td> <td>OFF TO GOOD STS LATENCY TIME UNIT</td> </tr> <tr> <td>45:40</td> <td>OFF TO GOOD STS LATENCY</td> </tr> <tr> <td>39:38</td> <td>BETWEEN POWER CYCLES TIME UNIT</td> </tr> <tr> <td>37:24</td> <td>RECOMMENDED TIME BETWEEN POWER CYCLES</td> </tr> <tr> <td>23:22</td> <td>OFF TO GOOD STS TIME UNIT</td> </tr> <tr> <td>21:16</td> <td>OFF TO GOOD STS RECOUP COST</td> </tr> <tr> <td>15:14</td> <td>DEVSLEEP TO PHYRDY TIME UNIT</td> </tr> <tr> <td>13:8</td> <td>DEVSLEEP TO PHYRDY RECOUP COST</td> </tr> <tr> <td>7:6</td> <td>SLUMBER TO DEVSLEEP TIME UNIT</td> </tr> <tr> <td>5:0</td> <td>SLUMBER TO DEVSLEEP RECOUP COST</td> </tr> </tbody> </table> | Bit | Meaning | 63 | TER SUPPORTED | 62:55 | Reserved | 54:53 | IN-STATE DEVSLEEP POWER UNIT | 52:48 | TYPICAL IN-STATE DEVSLEEP POWER | 47:46 | OFF TO GOOD STS LATENCY TIME UNIT | 45:40 | OFF TO GOOD STS LATENCY | 39:38 | BETWEEN POWER CYCLES TIME UNIT | 37:24 | RECOMMENDED TIME BETWEEN POWER CYCLES | 23:22 | OFF TO GOOD STS TIME UNIT | 21:16 | OFF TO GOOD STS RECOUP COST | 15:14 | DEVSLEEP TO PHYRDY TIME UNIT | 13:8 | DEVSLEEP TO PHYRDY RECOUP COST | 7:6 | SLUMBER TO DEVSLEEP TIME UNIT | 5:0 | SLUMBER TO DEVSLEEP RECOUP COST |
| Bit | Meaning | | | | | | | | | | | | | | | | | | | | | | | | | | | | | | | |
| 63 | TER SUPPORTED | | | | | | | | | | | | | | | | | | | | | | | | | | | | | | | |
| 62:55 | Reserved | | | | | | | | | | | | | | | | | | | | | | | | | | | | | | | |
| 54:53 | IN-STATE DEVSLEEP POWER UNIT | | | | | | | | | | | | | | | | | | | | | | | | | | | | | | | |
| 52:48 | TYPICAL IN-STATE DEVSLEEP POWER | | | | | | | | | | | | | | | | | | | | | | | | | | | | | | | |
| 47:46 | OFF TO GOOD STS LATENCY TIME UNIT | | | | | | | | | | | | | | | | | | | | | | | | | | | | | | | |
| 45:40 | OFF TO GOOD STS LATENCY | | | | | | | | | | | | | | | | | | | | | | | | | | | | | | | |
| 39:38 | BETWEEN POWER CYCLES TIME UNIT | | | | | | | | | | | | | | | | | | | | | | | | | | | | | | | |
| 37:24 | RECOMMENDED TIME BETWEEN POWER CYCLES | | | | | | | | | | | | | | | | | | | | | | | | | | | | | | | |
| 23:22 | OFF TO GOOD STS TIME UNIT | | | | | | | | | | | | | | | | | | | | | | | | | | | | | | | |
| 21:16 | OFF TO GOOD STS RECOUP COST | | | | | | | | | | | | | | | | | | | | | | | | | | | | | | | |
| 15:14 | DEVSLEEP TO PHYRDY TIME UNIT | | | | | | | | | | | | | | | | | | | | | | | | | | | | | | | |
| 13:8 | DEVSLEEP TO PHYRDY RECOUP COST | | | | | | | | | | | | | | | | | | | | | | | | | | | | | | | |
| 7:6 | SLUMBER TO DEVSLEEP TIME UNIT | | | | | | | | | | | | | | | | | | | | | | | | | | | | | | | |
| 5:0 | SLUMBER TO DEVSLEEP RECOUP COST | | | | | | | | | | | | | | | | | | | | | | | | | | | | | | | |

Table 182 Serial ATA Log Page - Continued -

| Offset | Type | Content | | | | | | | | | | | | | | | | | | | | | | | | | | | | | | |
|---------|--|--|-----|---------|----|----------------|-------|----------|-------|------------------------------|-------|--------------------------------|-------|------------------------------|-------|--------------------|-------|--|-------|--|-------|-------------------------------|-------|---------------------------------|-------|----------------------|------|------------------------|-----|----------------------|-----|------------------------|
| 64..71 | QWord | TRANSITIONAL ENERGY REPORTING EXTENDED | | | | | | | | | | | | | | | | | | | | | | | | | | | | | | |
| | | <table border="0"> <thead> <tr> <th>Bit</th> <th>Meaning</th> </tr> </thead> <tbody> <tr> <td>63</td> <td>TERE SUPPORTED</td> </tr> <tr> <td>62:47</td> <td>Reserved</td> </tr> <tr> <td>46:45</td> <td>IN-STATE SLUMBER POWER UNITS</td> </tr> <tr> <td>44:40</td> <td>TYPICAL IN-STATE SLUMBER POWER</td> </tr> <tr> <td>39:38</td> <td>PM2 TO PM0 LATENCY TIME UNIT</td> </tr> <tr> <td>37:32</td> <td>PM2 TO PM0 LATENCY</td> </tr> <tr> <td>31:30</td> <td>OFF TO GOOD STS RELATIVE TO DEVSLEEP/PM2 TIME UNIT</td> </tr> <tr> <td>29:24</td> <td>OFF TO GOOD STS RELATIVE TO DEVSLEEP/PM2 RECOUP COST</td> </tr> <tr> <td>23:22</td> <td>DEVSLEEP/PM2 TO OFF TIME UNIT</td> </tr> <tr> <td>21:16</td> <td>DEVSLEEP/PM2 TO OFF RECOUP COST</td> </tr> <tr> <td>15:14</td> <td>PM2 TO PM0 TIME UNIT</td> </tr> <tr> <td>13:8</td> <td>PM2 TO PM0 RECOUP COST</td> </tr> <tr> <td>7:6</td> <td>PM0 TO PM2 TIME UNIT</td> </tr> <tr> <td>5:0</td> <td>PM0 TO PM2 RECOUP COST</td> </tr> </tbody> </table> | Bit | Meaning | 63 | TERE SUPPORTED | 62:47 | Reserved | 46:45 | IN-STATE SLUMBER POWER UNITS | 44:40 | TYPICAL IN-STATE SLUMBER POWER | 39:38 | PM2 TO PM0 LATENCY TIME UNIT | 37:32 | PM2 TO PM0 LATENCY | 31:30 | OFF TO GOOD STS RELATIVE TO DEVSLEEP/PM2 TIME UNIT | 29:24 | OFF TO GOOD STS RELATIVE TO DEVSLEEP/PM2 RECOUP COST | 23:22 | DEVSLEEP/PM2 TO OFF TIME UNIT | 21:16 | DEVSLEEP/PM2 TO OFF RECOUP COST | 15:14 | PM2 TO PM0 TIME UNIT | 13:8 | PM2 TO PM0 RECOUP COST | 7:6 | PM0 TO PM2 TIME UNIT | 5:0 | PM0 TO PM2 RECOUP COST |
| Bit | Meaning | | | | | | | | | | | | | | | | | | | | | | | | | | | | | | | |
| 63 | TERE SUPPORTED | | | | | | | | | | | | | | | | | | | | | | | | | | | | | | | |
| 62:47 | Reserved | | | | | | | | | | | | | | | | | | | | | | | | | | | | | | | |
| 46:45 | IN-STATE SLUMBER POWER UNITS | | | | | | | | | | | | | | | | | | | | | | | | | | | | | | | |
| 44:40 | TYPICAL IN-STATE SLUMBER POWER | | | | | | | | | | | | | | | | | | | | | | | | | | | | | | | |
| 39:38 | PM2 TO PM0 LATENCY TIME UNIT | | | | | | | | | | | | | | | | | | | | | | | | | | | | | | | |
| 37:32 | PM2 TO PM0 LATENCY | | | | | | | | | | | | | | | | | | | | | | | | | | | | | | | |
| 31:30 | OFF TO GOOD STS RELATIVE TO DEVSLEEP/PM2 TIME UNIT | | | | | | | | | | | | | | | | | | | | | | | | | | | | | | | |
| 29:24 | OFF TO GOOD STS RELATIVE TO DEVSLEEP/PM2 RECOUP COST | | | | | | | | | | | | | | | | | | | | | | | | | | | | | | | |
| 23:22 | DEVSLEEP/PM2 TO OFF TIME UNIT | | | | | | | | | | | | | | | | | | | | | | | | | | | | | | | |
| 21:16 | DEVSLEEP/PM2 TO OFF RECOUP COST | | | | | | | | | | | | | | | | | | | | | | | | | | | | | | | |
| 15:14 | PM2 TO PM0 TIME UNIT | | | | | | | | | | | | | | | | | | | | | | | | | | | | | | | |
| 13:8 | PM2 TO PM0 RECOUP COST | | | | | | | | | | | | | | | | | | | | | | | | | | | | | | | |
| 7:6 | PM0 TO PM2 TIME UNIT | | | | | | | | | | | | | | | | | | | | | | | | | | | | | | | |
| 5:0 | PM0 TO PM2 RECOUP COST | | | | | | | | | | | | | | | | | | | | | | | | | | | | | | | |
| 72..511 | | Reserved | | | | | | | | | | | | | | | | | | | | | | | | | | | | | | |

Table 183 Serial ATA Log Page - Continued -

11.24 Read Log DMA Ext (47h)

| Command Block Output Registers | | | | | | | | | Command Block Input Registers | | | | | | | | | | |
|--------------------------------|----------|---|---|---|---|---|---|---|-------------------------------|--------------|--|-----------------|---|---|---|---|---|---|-----------------|
| Register | | 7 | 6 | 5 | 4 | 3 | 2 | 1 | 0 | Register | | 7 | 6 | 5 | 4 | 3 | 2 | 1 | 0 |
| Data Low | | - | - | - | - | - | - | - | - | Data Low | | - | - | - | - | - | - | - | - |
| Data High | | - | - | - | - | - | - | - | - | Data High | | - | - | - | - | - | - | - | - |
| Feature | Current | - | - | - | - | - | - | - | R- | Error | | | | | | | | | |
| | Previous | - | - | - | - | - | - | - | - | | | | | | | | | | ...See Below... |
| Sector Count | Current | V | V | V | V | V | V | V | V | Sector Count | | HOB=0 | - | - | - | - | - | - | - |
| | Previous | V | V | V | V | V | V | V | V | | | HOB=1 | - | - | - | - | - | - | - |
| LBA Low | Current | V | V | V | V | V | V | V | V | LBA Low | | HOB=0 | - | - | - | - | - | - | - |
| | Previous | - | - | - | - | - | - | - | - | | | HOB=1 | - | - | - | - | - | - | - |
| LBA Mid | Current | V | V | V | V | V | V | V | V | LBA Mid | | HOB=0 | - | - | - | - | - | - | - |
| | Previous | V | V | V | V | V | V | V | V | | | HOB=1 | - | - | - | - | - | - | - |
| LBA High | Current | - | - | - | - | - | - | - | - | LBA High | | HOB=0 | - | - | - | - | - | - | - |
| | Previous | - | - | - | - | - | - | - | - | | | HOB=1 | - | - | - | - | - | - | - |
| Device | | - | - | - | - | - | - | - | - | Device | | - | - | - | - | - | - | - | - |
| Command | | 0 | 1 | 0 | 0 | 0 | 1 | 1 | 1 | Status | | ...See Below... | | | | | | | |

| Error Register | | | | | | | |
|----------------|-----|---|-----|---|-----|-----|-----|
| 7 | 6 | 5 | 4 | 3 | 2 | 1 | 0 |
| CRC | UNC | 0 | IDN | 0 | ABT | T0N | AMN |
| V | V | 0 | V | 0 | V | 0 | 0 |

| Status Register | | | | | | | |
|-----------------|-----|----|-----|-----|-----|-----|-----|
| 7 | 6 | 5 | 4 | 3 | 2 | 1 | 0 |
| BSY | RDY | DF | DSC | DRQ | COR | IDX | ERR |
| 0 | V | 0 | V | - | 0 | 0 | V |

Table 184 Read Log DMA Ext Command (47h)

The content of this command is the same as Read Log Ext. See 11.23 Read Log Ext (2Fh)

11.25 Read Multiple (C4h)

| Command Block Output Registers | | | | | | | | |
|--------------------------------|---|---|---|---|---|---|---|---|
| Register | 7 | 6 | 5 | 4 | 3 | 2 | 1 | 0 |
| Data | - | - | - | - | - | - | - | - |
| Feature | - | - | - | - | - | - | - | - |
| Sector Count | V | V | V | V | V | V | V | V |
| Sector Number | V | V | V | V | V | V | V | V |
| Cylinder Low | V | V | V | V | V | V | V | V |
| Cylinder High | V | V | V | V | V | V | V | V |
| Device/Head | 1 | L | 1 | D | H | H | H | H |
| Command | 1 | 1 | 0 | 0 | 0 | 1 | 0 | 0 |

| Command Block Input Registers | | | | | | | | |
|-------------------------------|-----------------|---|---|---|---|---|---|---|
| Register | 7 | 6 | 5 | 4 | 3 | 2 | 1 | 0 |
| Data | - | - | - | - | - | - | - | - |
| Error | ...See Below... | | | | | | | |
| Sector Count | V | V | V | V | V | V | V | V |
| Sector Number | V | V | V | V | V | V | V | V |
| Cylinder Low | V | V | V | V | V | V | V | V |
| Cylinder High | V | V | V | V | V | V | V | V |
| Device/Head | - | - | - | - | H | H | H | H |
| Status | ...See Below... | | | | | | | |

| Error Register | | | | | | | |
|----------------|-----|---|-----|---|-----|-----|-----|
| 7 | 6 | 5 | 4 | 3 | 2 | 1 | 0 |
| CRC | UNC | 0 | IDN | 0 | ABT | T0N | AMN |
| 0 | V | 0 | V | 0 | V | 0 | 0 |

| Status Register | | | | | | | |
|-----------------|-----|----|-----|-----|-----|-----|-----|
| 7 | 6 | 5 | 4 | 3 | 2 | 1 | 0 |
| BSY | RDY | DF | DSC | DRQ | COR | IDX | ERR |
| 0 | V | 0 | V | - | 0 | - | V |

Table 185 Read Multiple Commands (C4h)

The Read Multiple command reads one or more sectors of data from disk media, and then transfers the data from the device to the host.

The sectors are transferred through the Data Register 16 bits at a time. Command execution is identical to the Read Sector(s) command except that an interrupt is generated for each block (as defined by the Set Multiple command) instead of for each sector.

11.26 Read Multiple Ext (29h)

| Command Block Output Registers | | | | | | | | |
|--------------------------------|----------|---|---|---|---|---|---|---|
| Register | 7 | 6 | 5 | 4 | 3 | 2 | 1 | 0 |
| Data Low | - | - | - | - | - | - | - | - |
| Data High | - | - | - | - | - | - | - | - |
| Feature | Current | - | - | - | - | - | - | - |
| | Previous | - | - | - | - | - | - | - |
| Sector Count | Current | V | V | V | V | V | V | V |
| | Previous | V | V | V | V | V | V | V |
| Sector Number | Current | V | V | V | V | V | V | V |
| | Previous | V | V | V | V | V | V | V |
| Cylinder Low | Current | V | V | V | V | V | V | V |
| | Previous | V | V | V | V | V | V | V |
| Cylinder High | Current | V | V | V | V | V | V | V |
| | Previous | V | V | V | V | V | V | V |
| Device/Head | - | 1 | - | D | - | - | - | - |
| Command | 0 | 0 | 1 | 0 | 1 | 0 | 0 | 1 |

| Command Block Input Registers | | | | | | | | |
|-------------------------------|-----------------|---|---|---|---|---|---|---|
| Register | 7 | 6 | 5 | 4 | 3 | 2 | 1 | 0 |
| Data Low | - | - | - | - | - | - | - | - |
| Data High | - | - | - | - | - | - | - | - |
| Error | ...See Below... | | | | | | | |
| Sector Count | HOB=0 | - | - | - | - | - | - | - |
| | HOB=1 | - | - | - | - | - | - | - |
| Sector Number | HOB=0 | V | V | V | V | V | V | V |
| | HOB=1 | V | V | V | V | V | V | V |
| Cylinder Low | HOB=0 | V | V | V | V | V | V | V |
| | HOB=1 | V | V | V | V | V | V | V |
| Cylinder High | HOB=0 | V | V | V | V | V | V | V |
| | HOB=1 | V | V | V | V | V | V | V |
| Device/Head | - | - | - | - | - | - | - | - |
| Status | ...See Below... | | | | | | | |

| Error Register | | | | | | | |
|----------------|-----|---|-----|---|-----|-----|-----|
| 7 | 6 | 5 | 4 | 3 | 2 | 1 | 0 |
| CRC | UNC | 0 | IDN | 0 | ABT | T0N | AMN |
| 0 | V | 0 | V | 0 | V | 0 | 0 |

| Status Register | | | | | | | |
|-----------------|-----|----|-----|-----|-----|-----|-----|
| 7 | 6 | 5 | 4 | 3 | 2 | 1 | 0 |
| BSY | RDY | DF | DSC | DRQ | COR | IDX | ERR |
| 0 | V | 0 | V | - | 0 | - | V |

Table 186 Read Multiple Ext Command (29h)

The Read Multiple Ext command reads one or more sectors of data from disk media, and then transfers the data from the device to the host.

The sectors are transferred through the Data Register 16 bits at a time. Command execution is identical to the Read Sector(s) command except that an interrupt is generated for each block (as defined by the Set Multiple command) instead of for each sector.

Output Parameters To The Device

| | |
|-------------------------------|--|
| Sector Count Current | The number of continuous sectors to be transferred low order, bits (7:0). |
| Sector Count Previous | The number of continuous sectors to be transferred high order, bits (15:8). If 0000h is specified in the Sector Count register, then 65,536 sectors will be transferred. |
| Sector Number Current | LBA (7:0). |
| Sector Number Previous | LBA (31:24). |
| Cylinder Low Current | LBA (15:8). |
| Cylinder Low Previous | LBA (39:32). |
| Cylinder High Current | LBA (23:16). |
| Cylinder High Previous | LBA (47:40). |

Input Parameters From The Device

| | |
|------------------------------|--|
| Sector Number (HOB=0) | LBA (7:0) of the address of the first unrecoverable error. |
| Sector Number (HOB=1) | LBA (31:24) of the address of the first unrecoverable error. |
| Cylinder Low (HOB=0) | LBA (15:8) of the address of the first unrecoverable error. |
| Cylinder Low (HOB=1) | LBA (39:32) of the address of the first unrecoverable error. |
| Cylinder High (HOB=0) | LBA (23:16) of the address of the first unrecoverable error. |
| Cylinder High (HOB=1) | LBA (47:40) of the address of the first unrecoverable error. |

11.27 Read Native Max Address (F8h)

| Block Output Registers Command | | | | | | | | |
|--------------------------------|---|---|---|---|---|---|---|---|
| Register | 7 | 6 | 5 | 4 | 3 | 2 | 1 | 0 |
| Data | - | - | - | - | - | - | - | - |
| Feature | - | - | - | - | - | - | - | - |
| Sector Count | - | - | - | - | - | - | - | - |
| Sector Number | - | - | - | - | - | - | - | - |
| Cylinder Low | - | - | - | - | - | - | - | - |
| Cylinder High | - | - | - | - | - | - | - | - |
| Device/Head | 1 | L | 1 | D | - | - | - | - |
| Command | 1 | 1 | 1 | 1 | 1 | 0 | 0 | 0 |

| Command Block Input Registers | | | | | | | | |
|-------------------------------|-----------------|---|---|---|---|---|---|---|
| Register | 7 | 6 | 5 | 4 | 3 | 2 | 1 | 0 |
| Data | - | - | - | - | - | - | - | - |
| Error | ...See Below... | | | | | | | |
| Sector Count | - | - | - | - | - | - | - | - |
| Sector Number | V | V | V | V | V | V | V | V |
| Cylinder Low | V | V | V | V | V | V | V | V |
| Cylinder High | V | V | V | V | V | V | V | V |
| Device/Head | - | - | - | - | H | H | H | H |
| Status | ...See Below... | | | | | | | |

| Error Register | | | | | | | |
|----------------|-----|---|-----|---|-----|-----|-----|
| 7 | 6 | 5 | 4 | 3 | 2 | 1 | 0 |
| CRC | UNC | 0 | IDN | 0 | ABT | TON | AMN |
| 0 | 0 | 0 | 0 | 0 | V | 0 | 0 |

| Status Register | | | | | | | |
|-----------------|-----|----|-----|-----|-----|-----|-----|
| 7 | 6 | 5 | 4 | 3 | 2 | 1 | 0 |
| BSY | RDY | DF | DSC | DRQ | COR | IDX | ERR |
| 0 | V | 0 | - | - | 0 | - | V |

Table 187 Read Native Max ADDRESS (F8h)

This command returns the native max LBA/CYL of HDD which is not affected by Set Max Address command.

The 48-bit native max address is greater than 268,435,455; the Read Native Max Address command shall return a value of 268,435,455.

Input Parameters From The Device

- Sector Number** In LBA mode, this register contains native max LBA bits 0-7. (L=1)
In CHS mode, this register contains native max sector number. (L=0)
- Cylinder High/Low** In LBA mode, this register contains native max LBA bits 8-15 (Low), 16-23 (High). (L=1)
In CHS mode, this register contains native max cylinder number. (L=0)
- H** In LBA mode, this register contains native max LBA bits 24-27. (L=1)
In CHS mode, this register contains native max head number. (L=0)

11.28 Read Native Max Address Ext (27h)

| Command Block Output Registers | | | | | | | | | Command Block Input Registers | | | | | | | | | | |
|--------------------------------|----------|---|---|---|---|---|---|---|-------------------------------|---------------|-----------------|-----------------|---|---|---|---|---|---|---|
| Register | | 7 | 6 | 5 | 4 | 3 | 2 | 1 | 0 | Register | | 7 | 6 | 5 | 4 | 3 | 2 | 1 | 0 |
| Data Low | | - | - | - | - | - | - | - | - | Data Low | | - | - | - | - | - | - | - | - |
| Data High | | - | - | - | - | - | - | - | - | Data High | | - | - | - | - | - | - | - | - |
| Feature | Current | - | - | - | - | - | - | - | - | Error | | ...See Below... | | | | | | | |
| | Previous | - | - | - | - | - | - | - | - | Sector Count | HOB=0 | - | - | - | - | - | - | - | - |
| Sector Count | Current | - | - | - | - | - | - | - | - | | HOB=1 | - | - | - | - | - | - | - | - |
| | Previous | - | - | - | - | - | - | - | - | Sector Number | HOB=0 | V | V | V | V | V | V | V | V |
| Sector Number | Current | - | - | - | - | - | - | - | - | | HOB=1 | V | V | V | V | V | V | V | V |
| | Previous | - | - | - | - | - | - | - | - | Cylinder Low | HOB=0 | V | V | V | V | V | V | V | V |
| Cylinder Low | Current | - | - | - | - | - | - | - | - | | HOB=1 | V | V | V | V | V | V | V | V |
| | Previous | - | - | - | - | - | - | - | - | Cylinder High | HOB=0 | V | V | V | V | V | V | V | V |
| Cylinder High | Current | - | - | - | - | - | - | - | - | | HOB=1 | V | V | V | V | V | V | V | V |
| | Previous | - | - | - | - | - | - | - | - | Device/Head | - | - | - | - | - | - | - | - | |
| Device/Head | | 1 | 1 | 1 | D | - | - | - | - | Status | ...See Below... | | | | | | | | |
| Command | | 0 | 0 | 1 | 0 | 0 | 1 | 1 | 1 | | | | | | | | | | |

| Error Register | | | | | | | |
|----------------|-----|---|-----|---|-----|-----|-----|
| 7 | 6 | 5 | 4 | 3 | 2 | 1 | 0 |
| CRC | UNC | 0 | IDN | 0 | ABT | TON | AMN |
| 0 | 0 | 0 | 0 | 0 | V | 0 | 0 |

| Status Register | | | | | | | |
|-----------------|-----|----|-----|-----|-----|-----|-----|
| 7 | 6 | 5 | 4 | 3 | 2 | 1 | 0 |
| BSY | RDY | DF | DSC | DRQ | COR | IDX | ERR |
| 0 | V | 0 | - | - | 0 | - | V |

Table 188 Read Native Max Address Ext (27h)

This command returns the native max LBA of HDD which is not affected by Set Max Address Ext command.

Input Parameters From The Device

- Sector Number (HOB=0)** LBA (7:0) of the address of the Native max address.
- Sector Number (HOB=1)** LBA (31:24) of the address of the Native max address.
- Cylinder Low (HOB=0)** LBA (15:8) of the address of the Native max address.
- Cylinder Low (HOB=1)** LBA (39:32) of the address of the Native max address.
- Cylinder High (HOB=0)** LBA (23:16) of the address of the Native max address.
- Cylinder High (HOB=1)** LBA (47:40) of the address of the Native max address.

11.29 Read Sector(s) (20h/21h)

| Command Block Output Registers | | | | | | | | |
|--------------------------------|---|---|---|---|---|---|---|---|
| Register | 7 | 6 | 5 | 4 | 3 | 2 | 1 | 0 |
| Data | - | - | - | - | - | - | - | - |
| Feature | - | - | - | - | - | - | - | - |
| Sector Count | V | V | V | V | V | V | V | V |
| Sector Number | V | V | V | V | V | V | V | V |
| Cylinder Low | V | V | V | V | V | V | V | V |
| Cylinder High | V | V | V | V | V | V | V | V |
| Device/Head | 1 | L | 1 | D | H | H | H | H |
| Command | 0 | 0 | 1 | 0 | 0 | 0 | 0 | R |

| Command Block Input Registers | | | | | | | | |
|-------------------------------|-----------------|---|---|---|---|---|---|---|
| Register | 7 | 6 | 5 | 4 | 3 | 2 | 1 | 0 |
| Data | - | - | - | - | - | - | - | - |
| Error | ...See Below... | | | | | | | |
| Sector Count | V | V | V | V | V | V | V | V |
| Sector Number | V | V | V | V | V | V | V | V |
| Cylinder Low | V | V | V | V | V | V | V | V |
| Cylinder High | V | V | V | V | V | V | V | V |
| Device/Head | - | - | - | - | H | H | H | H |
| Status | ...See Below... | | | | | | | |

| Error Register | | | | | | | |
|----------------|-----|---|-----|---|-----|-----|-----|
| 7 | 6 | 5 | 4 | 3 | 2 | 1 | 0 |
| CRC | UNC | 0 | IDN | 0 | ABT | T0N | AMN |
| 0 | V | 0 | V | 0 | V | 0 | 0 |

| Status Register | | | | | | | |
|-----------------|-----|----|-----|-----|-----|-----|-----|
| 7 | 6 | 5 | 4 | 3 | 2 | 1 | 0 |
| BSY | RDY | DF | DSC | DRQ | COR | IDX | ERR |
| 0 | V | 0 | V | - | 0 | - | V |

Table 189 Read Sector(s) Command (20h/21h)

The Read Sector(s) command reads one or more sectors of data from disk media, and then transfers the data from the device to the host.

The sectors are transferred through the Data Register 16 bits at a time.

If an uncorrectable error occurs, the read will be terminated at the failing sector.

Output Parameters To The Device

Sector Count The number of continuous sectors to be transferred. If zero is specified, then 256 sectors will be transferred.

Sector Number The sector number of the first sector to be transferred. (L=0)
In LBA mode, this register contains LBA bits 0 – 7. (L=1)

Cylinder High/Low The cylinder number of the first sector to be transferred. (L=0)
In LBA mode, this register contains LBA bits 8 – 15 (Low), 16 – 23 (High). (L=1)

H The head number of the first sector to be transferred. (L=0)
In LBA mode, this register contains LBA bits 24 – 27. (L=1)

R The retry bit, but this bit is ignored.

Input Parameters From The Device

Sector Count The number of requested sectors not transferred. This will be zero, unless an unrecoverable error occurs.

Sector Number The sector number of the last transferred sector. (L=0)
In LBA mode, this register contains current LBA bits 0 – 7. (L=1)

Cylinder High/Low The cylinder number of the last transferred sector. (L=0)
In LBA mode, this register contains current LBA bits 8 – 15 (Low), 16 – 23 (High). (L=1)

H The head number of the last transferred sector. (L=0)
In LBA mode, this register contains current LBA bits 24 – 27. (L=1)

11.30 Read Sector(s) Ext (24h)

| Command Block Output Registers | | | | | | | | |
|--------------------------------|----------|---|---|---|---|---|---|---|
| Register | 7 | 6 | 5 | 4 | 3 | 2 | 1 | 0 |
| Data Low | - | - | - | - | - | - | - | - |
| Data High | - | - | - | - | - | - | - | - |
| Feature | Current | - | - | - | - | - | - | - |
| | Previous | - | - | - | - | - | - | - |
| Sector Count | Current | V | V | V | V | V | V | V |
| | Previous | V | V | V | V | V | V | V |
| Sector Number | Current | V | V | V | V | V | V | V |
| | Previous | V | V | V | V | V | V | V |
| Cylinder Low | Current | V | V | V | V | V | V | V |
| | Previous | V | V | V | V | V | V | V |
| Cylinder High | Current | V | V | V | V | V | V | V |
| | Previous | V | V | V | V | V | V | V |
| Device/Head | 1 | 1 | 1 | D | - | - | - | - |
| Command | 0 | 0 | 1 | 0 | 0 | 1 | 0 | 0 |

| Command Block Input Registers | | | | | | | | |
|-------------------------------|-----------------|---|---|---|---|---|---|---|
| Register | 7 | 6 | 5 | 4 | 3 | 2 | 1 | 0 |
| Data Low | - | - | - | - | - | - | - | - |
| Data High | - | - | - | - | - | - | - | - |
| Error | ...See Below... | | | | | | | |
| Sector Count | HOB=0 | - | - | - | - | - | - | - |
| | HOB=1 | - | - | - | - | - | - | - |
| Sector Number | HOB=0 | V | V | V | V | V | V | V |
| | HOB=1 | V | V | V | V | V | V | V |
| Cylinder Low | HOB=0 | V | V | V | V | V | V | V |
| | HOB=1 | V | V | V | V | V | V | V |
| Cylinder High | HOB=0 | V | V | V | V | V | V | V |
| | HOB=1 | V | V | V | V | V | V | V |
| Device/Head | - | - | - | - | - | - | - | - |
| Status | ...See Below... | | | | | | | |

| Error Register | | | | | | | |
|----------------|-----|---|-----|---|-----|-----|-----|
| 7 | 6 | 5 | 4 | 3 | 2 | 1 | 0 |
| CRC | UNC | 0 | IDN | 0 | ABT | T0N | AMN |
| 0 | V | 0 | V | 0 | V | 0 | 0 |

| Status Register | | | | | | | |
|-----------------|-----|----|-----|-----|-----|-----|-----|
| 7 | 6 | 5 | 4 | 3 | 2 | 1 | 0 |
| BSY | RDY | DF | DSC | DRQ | COR | IDX | ERR |
| 0 | V | 0 | V | - | 0 | - | V |

Table 190 Read Sector(s) Ext Command (24h)

The Read Sector(s) Ext command reads from 1 to 65,536 sectors of data from disk media, and then transfers the data from the device to the host.

The sectors are transferred through the Data Register 16 bits at a time.

If an uncorrectable error occurs, the read will be terminated at the failing sector.

Output Parameters To The Device

| | |
|-------------------------------|---|
| Sector Count Current | The number of continuous sectors to be transferred low order, bits (7:0) |
| Sector Count Previous | The number of continuous sectors to be transferred high order, bits (15:8). If zero is specified in the Sector Count register, then 65,536 sectors will be transferred. |
| Sector Number Current | LBA (7:0). |
| Sector Number Previous | LBA (31:24). |
| Cylinder Low Current | LBA (15:8). |
| Cylinder Low Previous | LBA (39:32). |
| Cylinder High Current | LBA (23:16). |
| Cylinder High Previous | LBA (47:40). |

Input Parameters From The Device

| | |
|------------------------------|--|
| Sector Number (HOB=0) | LBA (7:0) of the address of the first unrecoverable error. |
| Sector Number (HOB=1) | LBA (31:24) of the address of the first unrecoverable error. |
| Cylinder Low (HOB=0) | LBA (15:8) of the address of the first unrecoverable error. |
| Cylinder Low (HOB=1) | LBA (39:32) of the address of the first unrecoverable error. |
| Cylinder High (HOB=0) | LBA (23:16) of the address of the first unrecoverable error. |
| Cylinder High (HOB=1) | LBA (47:40) of the address of the first unrecoverable error. |

11.31 Read Stream DMA Ext(2Ah)

| Command Block Output Registers | | | | | | | | |
|--------------------------------|----------|---|---|---|---|---|---|---|
| Register | 7 | 6 | 5 | 4 | 3 | 2 | 1 | 0 |
| Data Low | - | - | - | - | - | - | - | - |
| Data High | - | - | - | - | - | - | - | - |
| Feature | Current | V | V | V | V | - | V | V |
| | Previous | V | V | V | V | V | V | V |
| Sector Count | Current | V | V | V | V | V | V | V |
| | Previous | V | V | V | V | V | V | V |
| Sector Number | Current | V | V | V | V | V | V | V |
| | Previous | V | V | V | V | V | V | V |
| Cylinder Low | Current | V | V | V | V | V | V | V |
| | Previous | V | V | V | V | V | V | V |
| Cylinder High | Current | V | V | V | V | V | V | V |
| | Previous | V | V | V | V | V | V | V |
| Device/Head | 1 | 1 | 1 | D | - | - | - | - |
| Command | 0 | 0 | 1 | 0 | 1 | 0 | 1 | 0 |

| Command Block Input Registers | | | | | | | | |
|-------------------------------|-----------------|---|---|---|---|---|---|---|
| Register | 7 | 6 | 5 | 4 | 3 | 2 | 1 | 0 |
| Data Low | - | - | - | - | - | - | - | - |
| Data High | - | - | - | - | - | - | - | - |
| Error | ...See Below... | | | | | | | |
| Sector Count | HOB=0 | - | - | - | - | - | - | - |
| | HOB=1 | - | - | - | - | - | - | - |
| Sector Number | HOB=0 | V | V | V | V | V | V | V |
| | HOB=1 | V | V | V | V | V | V | V |
| Cylinder Low | HOB=0 | V | V | V | V | V | V | V |
| | HOB=1 | V | V | V | V | V | V | V |
| Cylinder High | HOB=0 | V | V | V | V | V | V | V |
| | HOB=1 | V | V | V | V | V | V | V |
| Device/Head | - | - | - | - | - | - | - | - |
| Status | ...See Below... | | | | | | | |

| Error Register | | | | | | | |
|----------------|-----|---|-----|---|-----|-----|------|
| 7 | 6 | 5 | 4 | 3 | 2 | 1 | 0 |
| CRC | UNC | 0 | IDN | 0 | ABT | T0N | CCTO |
| V | V | 0 | V | 0 | V | 0 | V |

| Status Register | | | | | | | |
|-----------------|-----|----|-----|-----|-----|-----|-----|
| 7 | 6 | 5 | 4 | 3 | 2 | 1 | 0 |
| BSY | RDY | SE | DWE | DRQ | COR | IDX | ERR |
| 0 | V | V | 0 | - | 0 | - | V |

Table 191 Read Stream DMA Ext Command (2Ah)

The Read Stream DMA Ext command reads one to 65536 sectors as specified in the Sector Count register. A value of 0000h in the Sector Count register requests 65536 sectors.

The RC bit indicates that the drive operate in a continuous read mode for the Read Stream command. When RC is cleared to zero the drive shall operate in normal Streaming read mode.

When the Read Continuous mode is enabled, the device shall transfer data of the requested length without setting the ERR bit to one. The SE bit shall be set to one if the data transferred includes errors. The data may be erroneous in this case.

If the Read Continuous bit is set to one, the device shall not stop execution of the command due to errors. If the RC bit is set to one and errors occur in reading or transfer of the data, the device shall continue to transfer the amount of data requested and then provide ending status with the BSY bit cleared to zero, the SE bit set to one, the ERR bit cleared to zero, and the type of error, ICRC, UNC, IDNF or ABRT, reported in the error log. If the RC bit is set to one and the Command Completion Time Limit expires, the device shall stop execution of the command and provide ending status with BSY bit cleared to zero, the SE bit set to one, the ERR bit cleared to zero, and report the fact that the Command Completion Time Limit expired by setting the CCTO bit in the error log to one, in all cases, the device shall attempt to transfer the amount of data requested within the Command Completion Time Limit event if some data transferred is in error.

Output Parameters To The Device

Feature Current

| | |
|-----------------------------|--|
| URG (bit7) | URG specifies an urgent transfer request. The Urgent bit specifies that the command should be completed in the minimum possible time by the device and shall be completed within the specified Command Completion Time Limit. |
| RC (bit6) | <p>RC specifies Read Continuous mode enabled. If the Read Continuous bit is set to one, the device shall not stop execution of the command due to errors.</p> <p>If the RC bit is set to one and errors occur in reading or transfer of the data, the device shall continue to transfer the amount of data requested and then provide ending status with BSY bit cleared to zero, the SE bit set to one, the ERR bit cleared to zero, and the type of error, ICRC, UNC, IDNF or ABRT reported in the error log.</p> <p>If the RC bit is set to one and the CCTL expires, the device shall stop execution of the command and provide ending status with the BSY bit cleared to zero, the SE bit set to one, the ERR bit cleared to zero, and report the fact that the CCTL expired by setting the CCTO bit in the error log to one.</p> <p>In all cases, the device shall attempt to transfer the amount of data requested within the CCTL even if some data transferred is in error.</p> |
| NS (bit5) | NS (Not Sequential) may be set to one if the next read stream command with the same Stream ID may not be sequential in LBA space. |
| HSE (bit4) | HSE (Handle Stream Error) specifies that this command starts at the LBA of the last reported error for this stream, so the device may attempt to continue its corresponding error recovery sequence where it left off earlier. |
| Stream ID (bit 0..2) | Stream ID specifies the stream to be read. The device shall operate according to the Stream ID set by the Read Stream command. |

Feature Previous

| | |
|-------------------|--|
| CCTL (7:0) | <p>The time allowed for the current command's completion is calculated as follows: Command Completion Time Limit = (content of the Feature register Previous) * (Identify Device words (99:98)) microseconds</p> <p>If the value is zero, the device shall use the Default CCTL supplied with a previous Configure Stream command for this Stream ID. If the Default CCTL is zero, or no previous Configure Stream command was defined for this Stream ID, the drive will ignore the CCTL. The time is measured from the write of the command register to the final INTRQ for command completion. The device has minimum CCTL value. When the specified value is shorter than the minimum value, CCTL is set to the minimum value. Actual minimum CCTL value is described in the "Deviations from Standard" section.</p> |
|-------------------|--|

Sector Count Current

The number of continuous sectors to be transferred low order, bits (7:0)

Sector Count Previous

The number of continuous sectors to be transferred high order, bits (15:8). If zero is specified in the Sector Count register, then 65,536 sectors will be transferred.

Sector Number Current

LBA (7:0).

Sector Number Previous

LBA (31:24).

Cylinder Low Current

LBA (15:8).

Cylinder Low Previous

LBA (39:32).

Cylinder High Current

LBA (23:16).

Cylinder High Previous

LBA (47:40).

Input Parameters From The Device

| | |
|------------------------------|---|
| Sector Number (HOB=0) | LBA (7:0) of the address of the first unrecoverable error. |
| Sector Number (HOB=1) | LBA (31:24) of the address of the first unrecoverable error. |
| Cylinder Low (HOB=0) | LBA (15:8) of the address of the first unrecoverable error. |
| Cylinder Low (HOB=1) | LBA (39:32) of the address of the first unrecoverable error. |
| Cylinder High (HOB=0) | LBA (23:16) of the address of the first unrecoverable error. |
| Cylinder High (HOB=1) | LBA (47:40) of the address of the first unrecoverable error. |
| CCTO (Error, bit 0) | CCTO bit shall be set to one if a Command Completion Time Limit Out error has occurred. |
| SE (Status, bit 5) | SE (Stream Error) shall be set to one if an error has occurred during the execution of the command and the RC bit is set to one, In this case the LBA returned in the Sector Number registers shall be the address of the first sector in error, and the Sector Count registers shall contain the number of consecutive sectors that may contain errors. If the RC bit is set to one when the command is issued and ICRC, UNC, IDNF, ABRT, or CCTO error occurs, the SE bit shall be set to one, the ERR bit shall be cleared to zero, and the bits that would normally be set in the Error register shall be set in the error log. |

11.32 Read Stream Ext (2Bh)

| Command Block Output Registers | | | | | | | | |
|--------------------------------|----------|---|---|---|---|---|---|---|
| Register | 7 | 6 | 5 | 4 | 3 | 2 | 1 | 0 |
| Data Low | - | - | - | - | - | - | - | - |
| Data High | - | - | - | - | - | - | - | - |
| Feature | Current | V | V | V | V | - | V | V |
| | Previous | V | V | V | V | V | V | V |
| Sector Count | Current | V | V | V | V | V | V | V |
| | Previous | V | V | V | V | V | V | V |
| Sector Number | Current | V | V | V | V | V | V | V |
| | Previous | V | V | V | V | V | V | V |
| Cylinder Low | Current | V | V | V | V | V | V | V |
| | Previous | V | V | V | V | V | V | V |
| Cylinder High | Current | V | V | V | V | V | V | V |
| | Previous | V | V | V | V | V | V | V |
| Device/Head | 1 | 1 | 1 | D | - | - | - | - |
| Command | 0 | 0 | 1 | 0 | 1 | 0 | 1 | 1 |

| Command Block Input Registers | | | | | | | | |
|-------------------------------|-----------------|---|---|---|---|---|---|---|
| Register | 7 | 6 | 5 | 4 | 3 | 2 | 1 | 0 |
| Data Low | - | - | - | - | - | - | - | - |
| Data High | - | - | - | - | - | - | - | - |
| Error | ...See Below... | | | | | | | |
| Sector Count | HOB=0 | - | - | - | - | - | - | - |
| | HOB=1 | - | - | - | - | - | - | - |
| Sector Number | HOB=0 | V | V | V | V | V | V | V |
| | HOB=1 | V | V | V | V | V | V | V |
| Cylinder Low | HOB=0 | V | V | V | V | V | V | V |
| | HOB=1 | V | V | V | V | V | V | V |
| Cylinder High | HOB=0 | V | V | V | V | V | V | V |
| | HOB=1 | V | V | V | V | V | V | V |
| Device/Head | - | - | - | - | - | - | - | - |
| Status | ...See Below... | | | | | | | |

| Error Register | | | | | | | |
|----------------|-----|---|-----|---|-----|-----|------|
| 7 | 6 | 5 | 4 | 3 | 2 | 1 | 0 |
| CRC | UNC | 0 | IDN | 0 | ABT | T0N | CCTO |
| V | V | 0 | V | 0 | V | 0 | V |

| Status Register | | | | | | | |
|-----------------|-----|----|-----|-----|-----|-----|-----|
| 7 | 6 | 5 | 4 | 3 | 2 | 1 | 0 |
| BSY | RDY | SE | DWE | DRQ | COR | IDX | ERR |
| 0 | V | V | 0 | - | 0 | - | V |

Table 192 Read Stream Ext Command (2Bh)

The Read Stream DMA Ext command reads one to 65536 sectors as specified in the Sector Count register. A value of 0000h in the Sector Count register requests 65536 sectors.

The RC bit indicates that the drive operate in a continuous read mode for the Read Stream command. When RC is cleared to zero the drive shall operate in normal Streaming read mode.

When the Read Continuous mode is enabled, the device shall transfer data of the requested length without setting the ERR bit. The SE bit shall be set to one if the data transferred includes errors. The data may be erroneous in this case.

If the Read Continuous bit is set to one, the device shall not stop execution of the command due to errors. If the RC bit is set to one and errors occur in reading or transfer of the data, the device shall continue to transfer the amount of data requested and then provide ending status with the BSY bit cleared to zero, the SE bit set to one, the ERR bit cleared to zero, and the type of error, ICRC,UNC,IDNF, or ABRT, reported in the error log. If the RC bit is set to one and the Command Completion Time Limit expires, the device shall stop execution of the command and provide ending status with BSY bit cleared to zero, the SE bit set to one, the ERR bit cleared to zero, and report the fact that the Command Completion Time Limit expired by setting the CCTO bit in the error log to one, In all cases, the device shall attempt to transfer the amount of data requested within the Command Completion Time Limit event if some data transferred is in error.

Output Parameters To The Device

Feature Current

| | |
|-----------------------------|---|
| URG (bit7) | URG specifies an urgent transfer request. The Urgent bit specifies that the command should be completed in the minimum possible time by the device and shall be completed within the specified Command Completion Time Limit. |
| RC (bit6) | RC specifies Read Continuous mode enabled. If the Read Continuous bit is set to one, the device shall not stop execution of the command due to errors. If the RC bit is set to one and errors occur in reading or transfer of the data, the device shall continue to transfer the amount of data requested and then provide ending status with BSY bit cleared to zero, the SE bit set to one, the ERR bit cleared to zero, and the type of error, UNC, IDNF or ABRT reported in the error log. If the RC bit is set to one and the CCTL expires, the device shall stop execution of the command and provide ending status with the BSY bit cleared to zero, the SE bit set to one, the ERR bit cleared to zero, and report the fact that the CCTL expired by setting the CCTO bit in the error log to one. In all cases, the device shall attempt to transfer the amount of data requested within the CCTL even if some data transferred is in error. |
| NS (bit5) | NS (Not Sequential) may be set to one if the next read stream command with the same Stream ID may not be sequential in LBA space. |
| HSE (bit4) | HSE (Handle Stream Error) specifies that this command starts at the LBA of the last reported error for this stream, so the device may attempt to continue its corresponding error recovery sequence where it left off earlier. |
| Stream ID (bit 0..2) | Stream ID specifies the stream to be read. The device shall operate according to the Stream ID set by the Read Stream command. |

Feature Previous

| | |
|-------------------|--|
| CCTL (7:0) | The time allowed for the current command's completion is calculated as follows: Command Completion Time Limit = (content of the Feature register Previous)* (Identify Device words (99:98)) microseconds If the value is zero, the device shall use the Default CCTL supplied with a previous Configure Stream command for this Stream ID. If the Default CCTL is zero, or no previous Configure Stream command was defined for this Stream ID, the device will ignore the CCTL. The time is measured from the write of the command register to command completion. The device has minimum CCTL value. When the specified value is shorter than the minimum value, CCTL is set to the minimum value. Actual minimum CCTL value is described in the "Deviations from Standard" section. |
|-------------------|--|

Sector Count Current

The number of continuous sectors to be transferred low order, bits (7:0)

Sector Count Previous

The number of continuous sectors to be transferred high order, bits (15:8). If zero is specified in the Sector Count register, then 65,536 sectors will be transferred.

Sector Number Current

LBA (7:0).

Sector Number Previous

LBA (31:24).

Cylinder Low Current

LBA (15:8).

Cylinder Low Previous

LBA (39:32).

Cylinder High Current

LBA (23:16).

Cylinder High Previous

LBA (47:40).

Input Parameters From The Device

| | |
|------------------------------|---|
| Sector Number (HOB=0) | LBA (7:0) of the address of the first unrecoverable error. |
| Sector Number (HOB=1) | LBA (31:24) of the address of the first unrecoverable error. |
| Cylinder Low (HOB=0) | LBA (15:8) of the address of the first unrecoverable error. |
| Cylinder Low (HOB=1) | LBA (39:32) of the address of the first unrecoverable error. |
| Cylinder High (HOB=0) | LBA (23:16) of the address of the first unrecoverable error. |
| Cylinder High (HOB=1) | LBA (47:40) of the address of the first unrecoverable error. |
| CCTO (Error, bit 0) | CCTO bit shall be set to one if a Command Completion Time Limit Out error has occurred. |
| SE (Status, bit 5) | SE (Stream Error) shall be set to one if an error has occurred during the execution of the command and the RC bit is set to one. In this case the LBA returned in the Sector Number registers shall be the address of the first sector in error, and the Sector Count registers shall contain the number of consecutive sectors that may contain errors. If the RC bit is set to one when the command is issued and a UNC, IDNF, ABRT, or CCTO error occurs, the SE bit shall be set to one, the ERR bit shall be cleared to zero, and the bits that would normally be set in the Error register shall be set in the error log. |

11.33 Read Verify Sector(s) (40h/41h)

| Command Block Output Registers | | | | | | | | |
|--------------------------------|---|---|---|---|---|---|---|---|
| Register | 7 | 6 | 5 | 4 | 3 | 2 | 1 | 0 |
| Data | - | - | - | - | - | - | - | - |
| Feature | - | - | - | - | - | - | - | - |
| Sector Count | V | V | V | V | V | V | V | V |
| Sector Number | V | V | V | V | V | V | V | V |
| Cylinder Low | V | V | V | V | V | V | V | V |
| Cylinder High | V | V | V | V | V | V | V | V |
| Device/Head | 1 | L | 1 | D | H | H | H | H |
| Command | 0 | 0 | 1 | 0 | 0 | 0 | 0 | R |

| Command Block Input Registers | | | | | | | | |
|-------------------------------|-----------------|---|---|---|---|---|---|---|
| Register | 7 | 6 | 5 | 4 | 3 | 2 | 1 | 0 |
| Data | - | - | - | - | - | - | - | - |
| Error | ...See Below... | | | | | | | |
| Sector Count | V | V | V | V | V | V | V | V |
| Sector Number | V | V | V | V | V | V | V | V |
| Cylinder Low | V | V | V | V | V | V | V | V |
| Cylinder High | V | V | V | V | V | V | V | V |
| Device/Head | - | - | - | - | H | H | H | H |
| Status | ...See Below... | | | | | | | |

| Error Register | | | | | | | |
|----------------|-----|---|-----|---|-----|-----|-----|
| 7 | 6 | 5 | 4 | 3 | 2 | 1 | 0 |
| CRC | UNC | 0 | IDN | 0 | ABT | TON | AMN |
| 0 | V | 0 | V | 0 | V | 0 | 0 |

| Status Register | | | | | | | |
|-----------------|-----|----|-----|-----|-----|-----|-----|
| 7 | 6 | 5 | 4 | 3 | 2 | 1 | 0 |
| BSY | RDY | DF | DSC | DRQ | COR | IDX | ERR |
| 0 | V | 0 | V | - | 0 | - | V |

Table 193 Read Verify Sector(s) Command (40h/41h)

The Read Verify Sector(s) verifies one or more sectors on the device. No data is transferred to the host.

The difference between Read Sector(s) command and Read Verify Sector(s) command is whether the data is transferred to the host or not.

If an uncorrectable error occurs, the read verify will be terminated at the failing sector.

Output Parameters To The Device

- Sector Count** The number of continuous sectors to be verified. If zero is specified, then 256 sectors will be verified.
- Sector Number** The sector number of the first sector to be transferred. (L=0)
In LBA mode, this register contains LBA bits 0 – 7. (L=1)
- Cylinder High/Low** The cylinder number of the first sector to be transferred. (L=0)
In LBA mode, this register contains LBA bits 8 – 15 (Low), 16 – 23 (High). (L=1)
- H** The head number of the first sector to be transferred. (L=0)
In LBA mode, this register contains LBA bits 24 – 27. (L=1)
- R** The retry bit, but this bit is ignored.

Input Parameters From The Device

- Sector Count** The number of requested sectors not verified. This will be zero, unless an unrecoverable error occurs.
- Sector Number** The sector number of the last transferred sector. (L=0)
In LBA mode, this register contains current LBA bits 0 – 7. (L=1)
- Cylinder High/Low** The cylinder number of the last transferred sector. (L=0)
In LBA mode, this register contains current LBA bits 8 – 15 (Low), 16 – 23 (High). (L=1)
- H** The head number of the last transferred sector. (L=0)
In LBA mode, this register contains current LBA bits 24 – 27. (L=1)

11.34 Read Verify Sector(s) Ext (42h)

| Command Block Output Registers | | | | | | | | |
|--------------------------------|----------|---|---|---|---|---|---|---|
| Register | 7 | 6 | 5 | 4 | 3 | 2 | 1 | 0 |
| Data Low | - | - | - | - | - | - | - | - |
| Data High | - | - | - | - | - | - | - | - |
| Feature | Current | - | - | - | - | - | - | - |
| | Previous | - | - | - | - | - | - | - |
| Sector Count | Current | V | V | V | V | V | V | V |
| | Previous | V | V | V | V | V | V | V |
| Sector Number | Current | V | V | V | V | V | V | V |
| | Previous | V | V | V | V | V | V | V |
| Cylinder Low | Current | V | V | V | V | V | V | V |
| | Previous | V | V | V | V | V | V | V |
| Cylinder High | Current | V | V | V | V | V | V | V |
| | Previous | V | V | V | V | V | V | V |
| Device/Head | 1 | 1 | 1 | D | - | - | - | - |
| Command | 0 | 0 | 1 | 0 | 0 | 0 | 1 | 0 |

| Command Block Input Registers | | | | | | | | |
|-------------------------------|-----------------|---|---|---|---|---|---|---|
| Register | 7 | 6 | 5 | 4 | 3 | 2 | 1 | 0 |
| Data Low | - | - | - | - | - | - | - | - |
| Data High | - | - | - | - | - | - | - | - |
| Error | ...See Below... | | | | | | | |
| Sector Count | HOB=0 | - | - | - | - | - | - | - |
| | HOB=1 | - | - | - | - | - | - | - |
| Sector Number | HOB=0 | V | V | V | V | V | V | V |
| | HOB=1 | V | V | V | V | V | V | V |
| Cylinder Low | HOB=0 | V | V | V | V | V | V | V |
| | HOB=1 | V | V | V | V | V | V | V |
| Cylinder High | HOB=0 | V | V | V | V | V | V | V |
| | HOB=1 | V | V | V | V | V | V | V |
| Device/Head | - | - | - | - | - | - | - | - |
| Status | ...See Below... | | | | | | | |

| Error Register | | | | | | | |
|----------------|-----|---|-----|---|-----|-----|-----|
| 7 | 6 | 5 | 4 | 3 | 2 | 1 | 0 |
| CRC | UNC | 0 | IDN | 0 | ABT | TON | AMN |
| 0 | V | 0 | V | 0 | V | 0 | 0 |

| Status Register | | | | | | | |
|-----------------|-----|----|-----|-----|-----|-----|-----|
| 7 | 6 | 5 | 4 | 3 | 2 | 1 | 0 |
| BSY | RDY | DF | DSC | DRQ | COR | IDX | ERR |
| 0 | V | 0 | V | - | 0 | - | V |

Table 194 Read Verify Sector(s) Ext Command (42h)

The Read Verify Sector(s) Ext verifies one or more sectors on the device. No data is transferred to the host.

The difference between the Read Sector(s) Ext command and the Read Verify Sector(s) Ext command is whether the data is transferred to the host or not.

If an uncorrectable error occurs, the Read Verify Sector(s) Ext will be terminated at the failing sector.

Output Parameters To The Device

| | |
|-------------------------------|---|
| Sector Count Current | The number of continuous sectors to be verified low order, bits (7:0). |
| Sector Count Previous | The number of continuous sectors to be verified high order, bits (15:8). If zero is specified in the Sector Count register, then 65,536 sectors will be verified. |
| Sector Number Current | LBA (7:0). |
| Sector Number Previous | LBA (31:24). |
| Cylinder Low Current | LBA (15:8). |
| Cylinder Low Previous | LBA (39:32). |
| Cylinder High Current | LBA (23:16). |
| Cylinder High Previous | LBA (47:40). |

Input Parameters From The Device

| | |
|------------------------------|--|
| Sector Number (HOB=0) | LBA (7:0) of the address of the first unrecoverable error. |
| Sector Number (HOB=1) | LBA (31:24) of the address of the first unrecoverable error. |
| Cylinder Low (HOB=0) | LBA (15:8) of the address of the first unrecoverable error. |
| Cylinder Low (HOB=1) | LBA (39:32) of the address of the first unrecoverable error. |
| Cylinder High (HOB=0) | LBA (23:16) of the address of the first unrecoverable error. |
| Cylinder High (HOB=1) | LBA (47:40) of the address of the first unrecoverable error. |

11.35 Recalibrate (1xh)

| Command Block Output Registers | | | | | | | | |
|--------------------------------|---|---|---|---|---|---|---|---|
| Register | 7 | 6 | 5 | 4 | 3 | 2 | 1 | 0 |
| Data | - | - | - | - | - | - | - | - |
| Feature | - | - | - | - | - | - | - | - |
| Sector Count | - | - | - | - | - | - | - | - |
| Sector Number | - | - | - | - | - | - | - | - |
| Cylinder Low | - | - | - | - | - | - | - | - |
| Cylinder High | - | - | - | - | - | - | - | - |
| Device/Head | 1 | - | 1 | D | - | - | - | - |
| Command | 0 | 0 | 0 | 1 | - | - | - | - |

| Command Block Input Registers | | | | | | | | |
|-------------------------------|-----------------|---|---|---|---|---|---|---|
| Register | 7 | 6 | 5 | 4 | 3 | 2 | 1 | 0 |
| Data | - | - | - | - | - | - | - | - |
| Error | ...See Below... | | | | | | | |
| Sector Count | - | - | - | - | - | - | - | - |
| Sector Number | - | - | - | - | - | - | - | - |
| Cylinder Low | - | - | - | - | - | - | - | - |
| Cylinder High | - | - | - | - | - | - | - | - |
| Device/Head | - | - | - | - | - | - | - | - |
| Status | ...See Below... | | | | | | | |

| Error Register | | | | | | | |
|----------------|-----|---|-----|---|-----|-----|-----|
| 7 | 6 | 5 | 4 | 3 | 2 | 1 | 0 |
| CRC | UNC | 0 | IDN | 0 | ABT | T0N | AMN |
| 0 | 0 | 0 | 0 | 0 | V | V | 0 |

| Status Register | | | | | | | |
|-----------------|-----|----|-----|-----|-----|-----|-----|
| 7 | 6 | 5 | 4 | 3 | 2 | 1 | 0 |
| BSY | RDY | DF | DSC | DRQ | COR | IDX | ERR |
| 0 | V | 0 | V | - | 0 | - | V |

Table 195 Recalibrate Command (1xh)

The Recalibrate command moves the read/write heads from anywhere on the disk to cylinder 0. If the device cannot reach cylinder 0, T0N (Track 0 Not Found) will be set in the Error Register.

11.36 Request Sense Data Ext (0Bh)

| Command Block Output Registers | | | | | | | | |
|--------------------------------|----------|---|---|---|---|---|---|---|
| Register | 7 | 6 | 5 | 4 | 3 | 2 | 1 | 0 |
| Data Low | - | - | - | - | - | - | - | - |
| Data High | - | - | - | - | - | - | - | - |
| Feature | Current | - | - | - | - | - | - | - |
| | Previous | - | - | - | - | - | - | - |
| Sector Count | Current | - | - | - | - | - | - | - |
| | Previous | - | - | - | - | - | - | - |
| Sector Number | Current | - | - | - | - | - | - | - |
| | Previous | - | - | - | - | - | - | - |
| Cylinder Low | Current | - | - | - | - | - | - | - |
| | Previous | - | - | - | - | - | - | - |
| Cylinder High | Current | - | - | - | - | - | - | - |
| | Previous | - | - | - | - | - | - | - |
| Device/Head | 1 | 1 | 1 | D | - | - | - | - |
| Command | 0 | 0 | 0 | 0 | 1 | 0 | 1 | 1 |

| Command Block Input Registers | | | | | | | | |
|-------------------------------|-----------------|---|---|---|---|---|---|---|
| Register | 7 | 6 | 5 | 4 | 3 | 2 | 1 | 0 |
| Data Low | - | - | - | - | - | - | - | - |
| Data High | - | - | - | - | - | - | - | - |
| Error | ...See Below... | | | | | | | |
| Sector Count | HOB=0 | - | - | - | - | - | - | - |
| | HOB=1 | - | - | - | - | - | - | - |
| Sector Number | HOB=0 | V | V | V | V | V | V | V |
| | HOB=1 | - | - | - | - | - | - | - |
| Cylinder Low | HOB=0 | V | V | V | V | V | V | V |
| | HOB=1 | - | - | - | - | - | - | - |
| Cylinder High | HOB=0 | - | - | - | - | V | V | V |
| | HOB=1 | - | - | - | - | - | - | - |
| Device/Head | - | - | - | - | - | - | - | - |
| Status | ...See Below... | | | | | | | |

| Error Register | | | | | | | |
|----------------|-----|---|-----|---|-----|-----|-----|
| 7 | 6 | 5 | 4 | 3 | 2 | 1 | 0 |
| CRC | UNC | 0 | IDN | 0 | ABT | T0N | AMN |
| 0 | 0 | 0 | 0 | 0 | V | 0 | 0 |

| Status Register | | | | | | | |
|-----------------|-----|----|-----|-----|-----|-----|-----|
| 7 | 6 | 5 | 4 | 3 | 2 | 1 | 0 |
| BSY | RDY | DF | DSC | DRQ | COR | IDX | ERR |
| 0 | V | 0 | - | - | 0 | V | V |

Table 196 Request Sense Data Ext command (0Bh)

The Request Sense Data Ext command allows the reporting of the most recent sense data from the device.

When sense data is available, the sense key (K), additional sense code (C), and additional sense code qualifier (Q) fields shall be set to values that are defined in the SPC-4 standard.

Otherwise, the sense key, additional sense code, and additional sense code qualifier shall be cleared to zero.

Default of Sense Data Reporting feature set is invalid.

Request Sense Data Ext returns KCQ of the latest command execution result except C3 Command. KCQ is deleted after Request Sense Data Ext execution.

If another command is executed before Request Sense Data Ext execution, KCQ will be overwritten at the result of another command.

Request Sense Data Ext is not dependent on a setup of NCQ Auto Sense.

Request Sense Data Ext returns KCQ of Error which occurred in NCQ Command.

In Error of the command Aborted in the state of CA, KCQ of Error which occurred in NCQ Command is not updated.

Error of Non NCQ Command can perform acquisition of Sense Data in Read Log Ext (Page = 10h).

However, if Request Sense Data Ext is performed before Read Log Ext execution, Sense Data will become invalid, and the contents of Sense Data acquired by Read Log Ext are not guaranteed.

About Status Register bit 1(Sense Data Available)

The Sense Data Available bit shall be set to one if:

- IDENTIFY DEVICE data word 119 bit 6 is set to one;
- IDENTIFY DEVICE data word 120 bit 6 is set to one; and
- Device has sense data to report after processing any command.

The Error bit and the Sense Data Available may both be set to one.
Bit 1 of the Status Register is obsolete if:

- a) IDENTIFY DEVICE data word 119 bit 6 is cleared to zero; or
- b) IDENTIFY DEVICE data word 120 bit 6 is cleared to zero.

| Input Parameters From The Device | |
|---|---|
| Sector Number (HOB=0) | Additional Sense Code Qualifier (Bit 7:0) |
| Cylinder Low (HOB=0) | Additional Sense Code (Bit 15:8) |
| Cylinder High (HOB=0) | Sense Key (Bit 19:16) |

Table 197 Sanitize Device Feature Set (B4h)

11.37 Sanitize Device Feature Set (B4h)

11.37.1 Crypto Scramble Ext Command (Feature: 0011h)

| Command Block Output Registers | | | | | | | | |
|--------------------------------|----------|---|---|---|---|---|---|---|
| Register | 7 | 6 | 5 | 4 | 3 | 2 | 1 | 0 |
| Data Low | - | - | - | - | - | - | - | - |
| Data High | - | - | - | - | - | - | - | - |
| Feature | Current | 0 | 0 | 0 | 1 | 0 | 0 | 0 |
| | Previous | 0 | 0 | 0 | 0 | 0 | 0 | 0 |
| Sector Count | Current | - | - | - | V | - | - | - |
| | Previous | - | - | - | - | - | - | - |
| Sector Number | Current | 0 | 1 | 1 | 1 | 0 | 0 | 0 |
| | Previous | 0 | 1 | 0 | 0 | 0 | 0 | 1 |
| Cylinder Low | Current | 0 | 1 | 1 | 1 | 1 | 0 | 0 |
| | Previous | - | - | - | - | - | - | - |
| Cylinder High | Current | 0 | 1 | 1 | 1 | 0 | 0 | 1 |
| | Previous | - | - | - | - | - | - | - |
| Device/Head | 1 | 1 | 1 | D | - | - | - | - |
| Command | 1 | 0 | 1 | 1 | 0 | 1 | 0 | 1 |

| Command Block Input Registers | | | | | | | | |
|-------------------------------|-----------------|---|---|---|---|---|---|---|
| Register | 7 | 6 | 5 | 4 | 3 | 2 | 1 | 0 |
| Data Low | - | - | - | - | - | - | - | - |
| Data High | - | - | - | - | - | - | - | - |
| Error | ...See Below... | | | | | | | |
| Sector Count | HOB=0 | - | - | - | - | - | - | - |
| | HOB=1 | V | V | V | - | - | - | - |
| Sector Number | HOB=0 | V | V | V | V | V | V | V |
| | HOB=1 | - | - | - | - | - | - | - |
| Cylinder Low | HOB=0 | V | V | V | V | V | V | V |
| | HOB=1 | - | - | - | - | - | - | - |
| Cylinder High | HOB=0 | - | - | - | - | - | - | - |
| | HOB=1 | - | - | - | - | - | - | - |
| Device/Head | - | - | - | - | - | - | - | - |
| Status | ...See Below... | | | | | | | |

| Error Register | | | | | | | |
|----------------|-----|---|-----|---|-----|-----|-----|
| 7 | 6 | 5 | 4 | 3 | 2 | 1 | 0 |
| CRC | UNC | 0 | IDN | 0 | ABT | T0N | AMN |
| V | Vs | 0 | V | 0 | V | 0 | 0 |

| Status Register | | | | | | | |
|-----------------|-----|----|-----|-----|-----|-----|-----|
| 7 | 6 | 5 | 4 | 3 | 2 | 1 | 0 |
| BSY | RDY | DF | DSC | DRQ | COR | IDX | ERR |
| 0 | V | 0 | V | - | 0 | - | V |

Table 198 Crypto Scramble Ext Command (B4h/0011h)

The CRYPTO SCRAMBLE EXT command supports an encryption model only.

The CRYPTO SCRAMBLE EXT command starts a crypto scramble operation (i.e., a sanitize operation that changes the internal encryption keys that are used for user data) causing the user data to become irretrievable.

The CRYPTO SCRAMBLE EXT command only is reported as supported if all user data is affected by changing internal encryption keys.

After a successful crypto scramble operation, the contents of the user data area may be indeterminate.

The CRYPTO SCRAMBLE EXT command only is processed if:

- the Sanitize Device feature set is supported
- the device is in the SD0: Sanitize Idle state, the SD3: Sanitize Operation Failed state, or the SD4: Sanitize Operation Succeeded state.

Output Parameters To The Device

Sector Count Current bit 4 The FAILURE MODE

- 1: the device may exit the SD3: Sanitize Operation Failed state with successful processing of a SANITIZE STATUS EXT command.
- 0: the SD3: Sanitize Operation Failed state returns command aborted for sanitize operations with the FAILURE MODE bit set to one until the device returns to the SD1: Sanitize Idle state.

Input Parameters From The Device

Sector Count Current bit 15 Sanitize Operation Completed Without Error.

- 1: the Sanitize Device state machine enters SD4: Sanitize Operation Succeeded.
- 0: the Sanitize Device state machine enters SD2: Sanitize Operation. The value of this bit is maintained across power-on resets.

Sector Count Current bit 14 Sanitize operation in progress

Sector Count Current bit 13 Device is in the SD1: Sanitize Frozen state

Cylinder Low (HOB=0) The Sanitize Progress Indication (15:8).
Progress indicator for the current sanitizes operation when the Sanitize Device state machine is in the SD2: Sanitize Operation state. This value is FFFFh if the Sanitize Device state machine is not in the SD2: Sanitize Operation state (i.e., a sanitize operation is not in process). The returned value is a numerator that has 65536 (10000h) as its denominator.

Sector Number (HOB=0) The Sanitize Progress Indication (7:0). Ditto.

Error Output

The ABORT bit is set to one if a SANITIZE DEVICE FREEZE LOCK EXT command has successfully completed since the last power-on reset.

The device returns command aborted if:

- a) the device is in the SD3:Sanitize Operation Failed state
- b) the completed sanitize command (i.e., CRYPTO SCRAMBLE EXT, or OVERWRITE EXT) specified the FAILURE MODE bit cleared to zero; and
- c) a CRYPTO SCRAMBLE EXT command with the FAILURE MODE bit set to one is received.

Sector Number (HOB=0) Sanitize Device Error (7:0)

- 00h Reason not reported
- 01h Sanitize Command Unsuccessful. The sanitize operation completed with physical sectors that are available to be allocated for user data that were not successfully sanitized.
- 02h Invalid or unsupported Sanitize Device Feature Field Value
- 03h Device is in the Sanitize Frozen state
- 04h..FFh Reserved

11.37.2 Overwrite Ext Command (Feature: 0014h)

| Command Block Output Registers | | | | | | | | |
|--------------------------------|----------|---|---|---|---|---|---|---|
| Register | 7 | 6 | 5 | 4 | 3 | 2 | 1 | 0 |
| Data Low | - | - | - | - | - | - | - | - |
| Data High | - | - | - | - | - | - | - | - |
| Feature | Current | 0 | 0 | 0 | 1 | 0 | 1 | 0 |
| | Previous | 0 | 0 | 0 | 0 | 0 | 0 | 0 |
| Sector Count | Current | V | - | - | V | V | V | V |
| | Previous | - | - | - | - | - | - | - |
| Sector Number | Current | V | V | V | V | V | V | V |
| | Previous | V | V | V | V | V | V | V |
| Cylinder Low | Current | V | V | V | V | V | V | V |
| | Previous | 0 | 1 | 0 | 1 | 0 | 1 | 1 |
| Cylinder High | Current | V | V | V | V | V | V | V |
| | Previous | 0 | 1 | 0 | 0 | 1 | 1 | 1 |
| Device/Head | 1 | 1 | 1 | D | - | - | - | - |
| Command | 1 | 0 | 1 | 1 | 0 | 1 | 0 | 1 |

| Command Block Input Registers | | | | | | | | |
|-------------------------------|-----------------|---|---|---|---|---|---|---|
| Register | 7 | 6 | 5 | 4 | 3 | 2 | 1 | 0 |
| Data Low | - | - | - | - | - | - | - | - |
| Data High | - | - | - | - | - | - | - | - |
| Error | ...See Below... | | | | | | | |
| Sector Count | HOB=0 | - | - | - | - | - | - | - |
| | HOB=1 | V | V | V | - | - | - | - |
| Sector Number | HOB=0 | V | V | V | V | V | V | V |
| | HOB=1 | - | - | - | - | - | - | - |
| Cylinder Low | HOB=0 | V | V | V | V | V | V | V |
| | HOB=1 | - | - | - | - | - | - | - |
| Cylinder High | HOB=0 | - | - | - | - | - | - | - |
| | HOB=1 | - | - | - | - | - | - | - |
| Device/Head | - | - | - | - | - | - | - | - |
| Status | ...See Below... | | | | | | | |

| Error Register | | | | | | | |
|----------------|-----|---|-----|---|-----|-----|-----|
| 7 | 6 | 5 | 4 | 3 | 2 | 1 | 0 |
| CRC | UNC | 0 | IDN | 0 | ABT | TON | AMN |
| V | Vs | 0 | V | 0 | V | 0 | 0 |

| Status Register | | | | | | | |
|-----------------|-----|----|-----|-----|-----|-----|-----|
| 7 | 6 | 5 | 4 | 3 | 2 | 1 | 0 |
| BSY | RDY | DF | DSC | DRQ | COR | IDX | ERR |
| 0 | V | 0 | V | - | 0 | - | V |

Table 199 Overwrite Ext Command (B4h/0014h)

The OVERWRITE EXT command starts an overwrite operation (i.e., a sanitize operation on the internal media that stores user data) which fills the user data area with a four byte pattern specified in the LBA field of the command. Parameters for the OVERWRITE EXT command include a count for multiple overwrites and the option to invert the four byte pattern between consecutive overwrite passes.

After the overwrite operation has been successfully applied, affected data blocks are readable without error.

The OVERWRITE EXT command only is processed if:

- the Sanitize Device feature set is supported
- the device is in the SD0: Sanitize Idle state, the SD3: Sanitize Operation Failed state, or the SD4: Sanitize Operation Succeeded state.

Output Parameters To The Device

| | |
|-------------------------------------|--|
| Sector Count Current bit 7 | Invert pattern between overwrite operations |
| Sector Count Current bit 4 | The FAILURE MODE 1: the device may exit the SD3: Sanitize Operation Failed state with successful processing of a SANITIZE STATUS EXT command. 0: the SD3: Sanitize Operation Failed state returns command aborted for sanitize operations with the FAILURE MODE bit set to one until the device returns to the SD1: Sanitize Idle state. |
| Sector Count Current bit 3:0 | OVERWRITE OPERATION COUNT This specifies how many write operations occur in the overwrite operation. A count of zero requests sixteen write operations. |
| Sector Number Previous | OVERWRITE PATTERN (31:24) The OVERWRITE PATTERN specifies a DWord pattern to be written across each physical sector affected by this command. |
| Cylinder High Current | OVERWRITE PATTERN (23:16). Ditto. |
| Cylinder Low Current | OVERWRITE PATTERN (15:8). Ditto. |
| Sector Number Current | OVERWRITE PATTERN (7:0). Ditto. |

Input Parameters From The Device

| | |
|------------------------------------|---|
| Sector Count Current bit 15 | Sanitize Operation Completed Without Error. 1: the Sanitize Device state machine enters SD4: Sanitize Operation Succeeded. 0: the Sanitize Device state machine enters SD2: Sanitize Operation. The value of this bit is maintained across power-on resets. |
| Sector Count Current bit 14 | Sanitize operation in progress |
| Sector Count Current bit 13 | Device is in the SD1: Sanitize Frozen state |
| Cylinder Low (HOB=0) | The Sanitize Progress Indication (15:8). Progress indicator for the current sanitizes operation when the Sanitize Device state machine is in the SD2: Sanitize Operation state. This value is FFFFh if the Sanitize Device state machine is not in the SD2: Sanitize Operation state (i.e., a sanitize operation is not in process). The returned value is a numerator that has 65536 (10000h) as its denominator. |
| Sector Number (HOB=0) | The Sanitize Progress Indication (7:0). Ditto. |

Error Output

The ABORT bit is set to one if a SANITIZE DEVICE FREEZE LOCK EXT command has successfully completed since the last power-on reset.

The device returns command aborted if:

- the device is in the SD3:Sanitize Operation Failed state
- the completed sanitize command (i.e., CRYPTO SCRAMBLE EXT, or OVERWRITE EXT) contained the FAILURE MODE bit cleared to zero
- an OVERWRITE EXT command with the FAILURE MODE bit set to one is received.

| | |
|------------------------------|---|
| Sector Number (HOB=0) | Sanitize Device Error (7:0) 00h Reason not reported 01h Sanitize Command Unsuccessful. The sanitize operation completed with physical sectors that are available to be allocated for user data that were not successfully sanitized. 02h Invalid or unsupported Sanitize Device Feature Field Value 03h Device is in the Sanitize Frozen state 04h..FFh Reserved |
|------------------------------|---|

11.37.3 Sanitize Freeze Lock Ext Command (Feature: 0020h)

| Command Block Output Registers | | | | | | | | |
|--------------------------------|----------|---|---|---|---|---|---|---|
| Register | 7 | 6 | 5 | 4 | 3 | 2 | 1 | 0 |
| Data Low | - | - | - | - | - | - | - | - |
| Data High | - | - | - | - | - | - | - | - |
| Feature | Current | 0 | 0 | 1 | 0 | 0 | 0 | 0 |
| | Previous | 0 | 0 | 0 | 0 | 0 | 0 | 0 |
| Sector Count | Current | - | - | - | - | - | - | - |
| | Previous | - | - | - | - | - | - | - |
| Sector Number | Current | 0 | 1 | 1 | 0 | 1 | 0 | 1 |
| | Previous | 0 | 1 | 0 | 0 | 0 | 1 | 1 |
| Cylinder Low | Current | 0 | 1 | 0 | 0 | 1 | 1 | 0 |
| | Previous | - | - | - | - | - | - | - |
| Cylinder High | Current | 0 | 1 | 1 | 1 | 0 | 0 | 1 |
| | Previous | - | - | - | - | - | - | - |
| Device/Head | 1 | 1 | 1 | D | - | - | - | - |
| Command | 1 | 0 | 1 | 1 | 0 | 1 | 0 | 1 |

| Command Block Input Registers | | | | | | | | |
|-------------------------------|-----------------|---|---|---|---|---|---|---|
| Register | 7 | 6 | 5 | 4 | 3 | 2 | 1 | 0 |
| Data Low | - | - | - | - | - | - | - | - |
| Data High | - | - | - | - | - | - | - | - |
| Error | ...See Below... | | | | | | | |
| Sector Count | HOB=0 | - | - | - | - | - | - | - |
| | HOB=1 | V | V | V | - | - | - | - |
| Sector Number | HOB=0 | V | V | V | V | V | V | V |
| | HOB=1 | - | - | - | - | - | - | - |
| Cylinder Low | HOB=0 | V | V | V | V | V | V | V |
| | HOB=1 | - | - | - | - | - | - | - |
| Cylinder High | HOB=0 | - | - | - | - | - | - | - |
| | HOB=1 | - | - | - | - | - | - | - |
| Device/Head | - | - | - | - | - | - | - | - |
| Status | ...See Below... | | | | | | | |

| Error Register | | | | | | | |
|----------------|-----|---|-----|---|-----|-----|-----|
| 7 | 6 | 5 | 4 | 3 | 2 | 1 | 0 |
| CRC | UNC | 0 | IDN | 0 | ABT | T0N | AMN |
| V | Vs | 0 | V | 0 | V | 0 | 0 |

| Status Register | | | | | | | |
|-----------------|-----|----|-----|-----|-----|-----|-----|
| 7 | 6 | 5 | 4 | 3 | 2 | 1 | 0 |
| BSY | RDY | DF | DSC | DRQ | COR | IDX | ERR |
| 0 | V | 0 | V | - | 0 | - | V |

Table 200 Sanitize Freeze Lock Ext Command (B4h/0020h)

The SANITIZE FREEZE LOCK EXT command sets the Sanitize Device state machine to the SD1: Sanitize Frozen state. After command completion all sanitize commands other than SANITIZE STATUS EXT command returns command aborted. The Sanitize Device state machine transitions from the SD1: Sanitize Frozen state to the SD0: Sanitize Idle state after a power-on reset or hardware reset.

Input Parameters From The Device

- Sector Count Current bit 15** Sanitize Operation Completed Without Error.
 1: the Sanitize Device state machine enters SD4: Sanitize Operation Succeeded.
 0: the Sanitize Device state machine enters SD2: Sanitize Operation. The value of this bit is maintained across power-on resets.
- Sector Count Current bit 14** Sanitize operation in progress
- Sector Count Current bit 13** Device is in the SD1: Sanitize Frozen state
- Cylinder Low (HOB=0)** The Sanitize Progress Indication (15:8).
 Progress indicator for the current sanitizes operation when the Sanitize Device state machine is in the SD2: Sanitize Operation state. This value is FFFFh if the Sanitize Device state machine is not in the SD2: Sanitize Operation state (i.e., a sanitize operation is not in process). The returned value is a numerator that has 65536 (10000h) as its denominator.
- Sector Number (HOB=0)** The Sanitize Progress Indication (7:0). Ditto.

Error Output

Sector Number (HOB=0)

Sanitize Device Error (7:0)

00h Reason not reported

01h Sanitize Command Unsuccessful. The sanitize operation completed with physical sectors that are available to be allocated for user data that were not successfully sanitized.

02h Invalid or unsupported Sanitize Device Feature Field Value

03h Device is in the Sanitize Frozen state

04h..FFh Reserved

11.37.4 Sanitize Status Ext Command (Feature: 0000h)

| Command Block Output Registers | | | | | | | | |
|--------------------------------|----------|---|---|---|---|---|---|---|
| Register | 7 | 6 | 5 | 4 | 3 | 2 | 1 | 0 |
| Data Low | - | - | - | - | - | - | - | - |
| Data High | - | - | - | - | - | - | - | - |
| Feature | Current | 0 | 0 | 0 | 0 | 0 | 0 | 0 |
| | Previous | 0 | 0 | 0 | 0 | 0 | 0 | 0 |
| Sector Count | Current | - | - | - | - | - | - | V |
| | Previous | - | - | - | - | - | - | - |
| Sector Number | Current | - | - | - | - | - | - | - |
| | Previous | - | - | - | - | - | - | - |
| Cylinder Low | Current | - | - | - | - | - | - | - |
| | Previous | - | - | - | - | - | - | - |
| Cylinder High | Current | - | - | - | - | - | - | - |
| | Previous | - | - | - | - | - | - | - |
| Device/Head | 1 | 1 | 1 | D | - | - | - | - |
| Command | 1 | 0 | 1 | 1 | 0 | 1 | 0 | 1 |

| Command Block Input Registers | | | | | | | | |
|-------------------------------|-----------------|---|---|---|---|---|---|---|
| Register | 7 | 6 | 5 | 4 | 3 | 2 | 1 | 0 |
| Data Low | - | - | - | - | - | - | - | - |
| Data High | - | - | - | - | - | - | - | - |
| Error | ...See Below... | | | | | | | |
| Sector Count | HOB=0 | - | - | - | - | - | - | - |
| | HOB=1 | V | V | V | - | - | - | - |
| Sector Number | HOB=0 | V | V | V | V | V | V | V |
| | HOB=1 | - | - | - | - | - | - | - |
| Cylinder Low | HOB=0 | V | V | V | V | V | V | V |
| | HOB=1 | - | - | - | - | - | - | - |
| Cylinder High | HOB=0 | - | - | - | - | - | - | - |
| | HOB=1 | - | - | - | - | - | - | - |
| Device/Head | - | - | - | - | - | - | - | - |
| Status | ...See Below... | | | | | | | |

| Error Register | | | | | | | |
|----------------|-----|---|-----|---|-----|-----|-----|
| 7 | 6 | 5 | 4 | 3 | 2 | 1 | 0 |
| CRC | UNC | 0 | IDN | 0 | ABT | T0N | AMN |
| V | Vs | 0 | V | 0 | V | 0 | 0 |

| Status Register | | | | | | | |
|-----------------|-----|----|-----|-----|-----|-----|-----|
| 7 | 6 | 5 | 4 | 3 | 2 | 1 | 0 |
| BSY | RDY | DF | DSC | DRQ | COR | IDX | ERR |
| 0 | V | 0 | V | - | 0 | - | V |

Table 201 Sanitize Status Ext Command (B4h/0000h)

The SANITIZE STATUS EXT command returns information about current or previously completed sanitizes operations. This includes:

- progress indication on a current sanitize operation
- whether a previous sanitize operation completed successfully or unsuccessfully
- if an unsupported sanitize device command was received.

The SANITIZE STATUS EXT command is valid in every state of the Sanitize Device state machine.

Output Parameters To The Device

Sector Count Current bit 0

CLEAR SANITIZE OPERATION FAILED

If Sanitize Device state machine is in the SD3: Sanitize Failed state:

- the FAILURE MODE bit was set to one in the Sanitize Device command that caused the sanitize operation
- the sanitize operation failed
- the CLEAR SANITIZE OPERATION FAILED bit is set to one in the SANITIZE STATUS EXT command then the Sanitize Device state machine transitions to the SD0: Sanitize Idle state.

If the CLEAR SANITIZE OPERATION FAILED bit is set to one in the SANITIZE STATUS EXT command, and the FAILURE MODE bit was set to zero in the Sanitize Device command that caused the sanitize operation, the SANITIZE STATUS EXT command returns command aborted.

Input Parameters From The Device

| | |
|------------------------------------|---|
| Sector Count Current bit 15 | Sanitize Operation Completed Without Error. 1: the Sanitize Device state machine enters SD4: Sanitize Operation Succeeded. 0: the Sanitize Device state machine enters SD2: Sanitize Operation. The value of this bit is maintained across power-on resets. |
| Sector Count Current bit 14 | Sanitize operation in progress |
| Sector Count Current bit 13 | Device is in the SD1: Sanitize Frozen state |
| Cylinder Low (HOB=0) | The Sanitize Progress Indication (15:8). Progress indicator for the current sanitizes operation when the Sanitize Device state machine is in the SD2: Sanitize Operation state. This value is FFFFh if the Sanitize Device state machine is not in the SD2: Sanitize Operation state (i.e., a sanitize operation is not in process). The returned value is a numerator that has 65536 (10000h) as its denominator. |
| Sector Number (HOB=0) | The Sanitize Progress Indication (7:0). Ditto. |

Error Output

After the sanitize operation has completed, if any physical sector that is available to be allocated for user data was not successfully sanitized, then this command returns the ABORT bit set to one.

| | |
|------------------------------|---|
| Sector Number (HOB=0) | Sanitize Device Error (7:0) 00h Reason not reported 01h Sanitize Command Unsuccessful. The sanitize operation completed with physical sectors that are available to be allocated for user data that were not successfully sanitized. 02h Invalid or unsupported Sanitize Device Feature Field Value 03h Device is in the Sanitize Frozen state 04h..FFh Reserved |
|------------------------------|---|

11.38 Security Disable Password (F6h)

| Command Block Output Registers | | | | | | | | |
|--------------------------------|---|---|---|---|---|---|---|---|
| Register | 7 | 6 | 5 | 4 | 3 | 2 | 1 | 0 |
| Data | - | - | - | - | - | - | - | - |
| Feature | - | - | - | - | - | - | - | - |
| Sector Count | - | - | - | - | - | - | - | - |
| Sector Number | - | - | - | - | - | - | - | - |
| Cylinder Low | - | - | - | - | - | - | - | - |
| Cylinder High | - | - | - | - | - | - | - | - |
| Device/Head | 1 | - | 1 | D | - | - | - | - |
| Command | 1 | 1 | 1 | 1 | 0 | 1 | 1 | 0 |

| Command Block Input Registers | | | | | | | | |
|-------------------------------|------------------|---|---|---|---|---|---|---|
| Register | 7 | 6 | 5 | 4 | 3 | 2 | 1 | 0 |
| Data | - | - | - | - | - | - | - | - |
| Error | ... See Below... | | | | | | | |
| Sector Count | - | - | - | - | - | - | - | - |
| Sector Number | - | - | - | - | - | - | - | - |
| Cylinder Low | - | - | - | - | - | - | - | - |
| Cylinder High | - | - | - | - | - | - | - | - |
| Device/Head | - | - | - | - | - | - | - | - |
| Status | ... See Below... | | | | | | | |

| Error Register | | | | | | | |
|----------------|-----|---|-----|---|-----|-----|-----|
| 7 | 6 | 5 | 4 | 3 | 2 | 1 | 0 |
| CRC | UNC | 0 | IDN | 0 | ABT | TON | AMN |
| 0 | 0 | 0 | 0 | 0 | V | 0 | 0 |

| Status Register | | | | | | | |
|-----------------|-----|----|-----|-----|-----|-----|-----|
| 7 | 6 | 5 | 4 | 3 | 2 | 1 | 0 |
| BSY | RDY | DF | DSC | DRQ | COR | IDX | ERR |
| 0 | V | 0 | V | - | 0 | - | V |

Table 202 Security Disable Password Command (F6h)

The Security Disable Password command disables the security mode feature (device lock function).

The Security Disable Password command requests a transfer of a single sector of data from the host including information specified in Table 195 on the page 238. Then the device checks the transferred password. If the User Password or Master Password matches the given password, the device disables the security mode feature (device lock function). This command does not change the Master Password which may be re-activated later by setting User Password. This command should be executed in device unlock mode.

When security is disabled and the Identifier bit is set to User, then the device shall return command aborted.

| Word | Description |
|--------|---|
| 00 | Control word bit 0 : Identifier (1-Mater, 0-User) bit 1-15 : Reserved |
| 01-16 | Password (32 bytes) |
| 17-255 | Reserved |

Table 203 Password Information for Security Disable Password Command

The device will compare the password sent from this host with that specified in the control word.

Identifier Zero indicates that the device should check the supplied password against the user password stored internally. One indicates that the device should check the given password against the master password stored internally.

11.39 Security Erase Prepare (F3h)

| Command Block Output Registers | | | | | | | | Command Block Input Registers | | | | | | | | | |
|--------------------------------|---|---|---|---|---|---|---|-------------------------------|---------------|-----------------|---|---|---|---|---|---|---|
| Register | 7 | 6 | 5 | 4 | 3 | 2 | 1 | 0 | Register | 7 | 6 | 5 | 4 | 3 | 2 | 1 | 0 |
| Data | - | - | - | - | - | - | - | - | Data | - | - | - | - | - | - | - | - |
| Feature | - | - | - | - | - | - | - | - | Error | ...See Below... | | | | | | | |
| Sector Count | - | - | - | - | - | - | - | - | Sector Count | - | - | - | - | - | - | - | - |
| Sector Number | - | - | - | - | - | - | - | - | Sector Number | - | - | - | - | - | - | - | - |
| Cylinder Low | - | - | - | - | - | - | - | - | Cylinder Low | - | - | - | - | - | - | - | - |
| Cylinder High | - | - | - | - | - | - | - | - | Cylinder High | - | - | - | - | - | - | - | - |
| Device/Head | 1 | - | 1 | D | - | - | - | - | Device/Head | - | - | - | - | - | - | - | - |
| Command | 1 | 1 | 1 | 1 | 0 | 0 | 1 | 1 | Status | ...See Below... | | | | | | | |

| Error Register | | | | | | | | Status Register | | | | | | | |
|----------------|-----|---|-----|---|-----|-----|-----|-----------------|-----|----|-----|-----|-----|-----|-----|
| 7 | 6 | 5 | 4 | 3 | 2 | 1 | 0 | 7 | 6 | 5 | 4 | 3 | 2 | 1 | 0 |
| CRC | UNC | 0 | IDN | 0 | ABT | T0N | AMN | BSY | RDY | DF | DSC | DRQ | COR | IDX | ERR |
| 0 | 0 | 0 | 0 | 0 | V | 0 | 0 | 0 | V | 0 | V | - | 0 | - | V |

Table 204 Security Erase Prepare Command (F3h)

The Security Erase Prepare Command must be issued immediately before the Security Erase Unit Command to enable device erasing and unlocking.

The Security Erase Prepare Command must be issued immediately before the Format Unit Command. This command is to prevent accidental erasure of the device.

This command does not request to transfer data.

11.40 Security Erase Unit (F4h)

| Command Block Output Registers | | | | | | | | |
|--------------------------------|---|---|---|---|---|---|---|---|
| Register | 7 | 6 | 5 | 4 | 3 | 2 | 1 | 0 |
| Data | - | - | - | - | - | - | - | - |
| Feature | - | - | - | - | - | - | - | - |
| Sector Count | - | - | - | - | - | - | - | - |
| Sector Number | - | - | - | - | - | - | - | - |
| Cylinder Low | - | - | - | - | - | - | - | - |
| Cylinder High | - | - | - | - | - | - | - | - |
| Device/Head | 1 | - | 1 | D | - | - | - | - |
| Command | 1 | 1 | 1 | 1 | 0 | 1 | 0 | 0 |

| Command Block Input Registers | | | | | | | | |
|-------------------------------|-----------------|---|---|---|---|---|---|---|
| Register | 7 | 6 | 5 | 4 | 3 | 2 | 1 | 0 |
| Data | - | - | - | - | - | - | - | - |
| Error | ...See Below... | | | | | | | |
| Sector Count | - | - | - | - | - | - | - | - |
| Sector Number | - | - | - | - | - | - | - | - |
| Cylinder Low | - | - | - | - | - | - | - | - |
| Cylinder High | - | - | - | - | - | - | - | - |
| Device/Head | - | - | - | - | - | - | - | - |
| Status | ...See Below... | | | | | | | |

| Error Register | | | | | | | |
|----------------|-----|---|-----|---|-----|-----|-----|
| 7 | 6 | 5 | 4 | 3 | 2 | 1 | 0 |
| CRC | UNC | 0 | IDN | 0 | ABT | T0N | AMN |
| 0 | 0 | 0 | V | 0 | V | 0 | 0 |

| Status Register | | | | | | | |
|-----------------|-----|----|-----|-----|-----|-----|-----|
| 7 | 6 | 5 | 4 | 3 | 2 | 1 | 0 |
| BSY | RDY | DF | DSC | DRQ | COR | IDX | ERR |
| 0 | V | 0 | V | - | 0 | - | V |

Table 205 Security Erase Unit Command (F4h)

The Security Erase Unit command initializes all user data sectors, and then disables the device lock function.

Note that the Security Erase Unit command initializes from LBA 0 to Native MAX LBA. Host MAX LBA set by Initialize Drive Parameter, Device Configuration Overlay, or Set MAX Address command is ignored. So the protected area by Set MAX Address command is also initialized.

This command requests to transfer a single sector data from the host including information specified in Table 205 on the page 251.

When security is disabled and the Identifier bit is set to User, then the device shall return command aborted.

If the password does not match, then the device rejects the command with an Aborted error.

| Word | Description |
|--------|--|
| 00 | Control word bit 0 : Identifier (1-Mater, 0-User) bit 1 : Erase mode (1- Enhanced, 0- Normal) Enhanced mode is not supported bit 2-15 : Reserved |
| 01-16 | Password (32 bytes) |
| 17-255 | Reserved |

Table 206 Erase Unit Information

Identifier Zero indicates that the device should check the supplied password against the user password stored internally. One indicates that the device should check the given password against the master password stored internally.

The Security Erase Unit command erases all user data and disables the security mode feature (device lock function). So after completing this command, all user data will be initialized to zero with write operation. At this time, it is not verified with read operation whether the sector of data is initialized correctly. Also, the defective sector information and the reassigned sector information for the device are not updated. The security erase prepare

command should be completed immediately prior to the Security Erase Unit command. If the device receives a Security Erase Unit command without a prior Security Erase Prepare command, the device aborts the security erase unit command.

This command disables the security mode feature (device lock function), however the master password is still stored internally within the device and may be re-activated later when a new user password is set. If you execute this command on disabling the security mode feature (device lock function), the password sent by the host is NOT compared with the password stored in the device for both the Master Password and the User Password, and then the device only erases all user data.

The execution time of this command is set in word 89 of Identify device information.

11.41 Security Freeze Lock (F5h)

| Command Block Output Registers | | | | | | | | |
|--------------------------------|---|---|---|---|---|---|---|---|
| Register | 7 | 6 | 5 | 4 | 3 | 2 | 1 | 0 |
| Data | - | - | - | - | - | - | - | - |
| Feature | - | - | - | - | - | - | - | - |
| Sector Count | - | - | - | - | - | - | - | - |
| Sector Number | - | - | - | - | - | - | - | - |
| Cylinder Low | - | - | - | - | - | - | - | - |
| Cylinder High | - | - | - | - | - | - | - | - |
| Device/Head | 1 | - | 1 | D | - | - | - | - |
| Command | 1 | 1 | 1 | 1 | 0 | 1 | 0 | 1 |

| Command Block Input Registers | | | | | | | | |
|-------------------------------|-----------------|---|---|---|---|---|---|---|
| Register | 7 | 6 | 5 | 4 | 3 | 2 | 1 | 0 |
| Data | - | - | - | - | - | - | - | - |
| Error | ...See Below... | | | | | | | |
| Sector Count | - | - | - | - | - | - | - | - |
| Sector Number | - | - | - | - | - | - | - | - |
| Cylinder Low | - | - | - | - | - | - | - | - |
| Cylinder High | - | - | - | - | - | - | - | - |
| Device/Head | - | - | - | - | - | - | - | - |
| Status | ...See Below... | | | | | | | |

| Error Register | | | | | | | |
|----------------|-----|---|-----|---|-----|-----|-----|
| 7 | 6 | 5 | 4 | 3 | 2 | 1 | 0 |
| CRC | UNC | 0 | IDN | 0 | ABT | T0N | AMN |
| 0 | 0 | 0 | 0 | 0 | V | 0 | 0 |

| Status Register | | | | | | | |
|-----------------|-----|----|-----|-----|-----|-----|-----|
| 7 | 6 | 5 | 4 | 3 | 2 | 1 | 0 |
| BSY | RDY | DF | DSC | DRQ | COR | IDX | ERR |
| 0 | V | 0 | - | - | 0 | - | V |

Table 207 Security Freeze Lock Command (F5h)

The Security Freeze Lock Command allows the device to enter frozen mode immediately.

After this command is completed, the command which updates Security Mode Feature (Device Lock Function) is rejected.

Frozen mode is quit only by Power off.

The following commands are rejected when the device is in frozen mode. For detail, refer to Table 36 and Table 37 on the page 67-68.

- Security Set Password
- Security Unlock
- Security Disable Password
- Security Erase Unit

11.42 Security Set Password (F1h)

| Command Block Output Registers | | | | | | | | |
|--------------------------------|---|---|---|---|---|---|---|---|
| Register | 7 | 6 | 5 | 4 | 3 | 2 | 1 | 0 |
| Data | - | - | - | - | - | - | - | - |
| Feature | - | - | - | - | - | - | - | - |
| Sector Count | - | - | - | - | - | - | - | - |
| Sector Number | - | - | - | - | - | - | - | - |
| Cylinder Low | - | - | - | - | - | - | - | - |
| Cylinder High | - | - | - | - | - | - | - | - |
| Device/Head | 1 | - | 1 | D | - | - | - | - |
| Command | 1 | 1 | 1 | 1 | 0 | 0 | 0 | 1 |

| Command Block Input Registers | | | | | | | | |
|-------------------------------|-----------------|---|---|---|---|---|---|---|
| Register | 7 | 6 | 5 | 4 | 3 | 2 | 1 | 0 |
| Data | - | - | - | - | - | - | - | - |
| Error | ...See Below... | | | | | | | |
| Sector Count | - | - | - | - | - | - | - | - |
| Sector Number | - | - | - | - | - | - | - | - |
| Cylinder Low | - | - | - | - | - | - | - | - |
| Cylinder High | - | - | - | - | - | - | - | - |
| Device/Head | - | - | - | - | - | - | - | - |
| Status | ...See Below... | | | | | | | |

| Error Register | | | | | | | |
|----------------|-----|---|-----|---|-----|-----|-----|
| 7 | 6 | 5 | 4 | 3 | 2 | 1 | 0 |
| CRC | UNC | 0 | IDN | 0 | ABT | TON | AMN |
| 0 | 0 | 0 | 0 | 0 | V | 0 | 0 |

| Status Register | | | | | | | |
|-----------------|-----|----|-----|-----|-----|-----|-----|
| 7 | 6 | 5 | 4 | 3 | 2 | 1 | 0 |
| BSY | RDY | DF | DSC | DRQ | COR | IDX | ERR |
| 0 | V | 0 | - | - | 0 | - | V |

Table 208 Security Set Password Command (F1h)

The Security Set Password command enables security mode feature (device lock function), and sets the master password or the user password.

The security mode feature (device lock function) is enabled by this command, and the device is not locked immediately. The device is locked after next power on reset. When the MASTER password is set by this command, the master password is registered internally, but the device is NOT locked after next power on reset or hard reset.

This command requests a transfer of a single sector of data from the host including the information specified in Table 208 on the page 254.

The data transferred controls the function of this command.

| Word | Description |
|--------|--|
| 00 | Control word bit 0 : Identifier (1-Mater, 0-User) bit 1-7 : Reserved bit 8 : Security level (1-Maximum, 0-High) bit 9-15 : Reserved |
| 01-16 | Password (32 byte) |
| 17 | Master Password Revision Code (valid if Word 0 bit 0 = 1) |
| 18-255 | Reserved |

Table 209 Security Set Password Information

| | |
|------------------------|---|
| Identifier | Zero indicates that the device regards Password as User Password. One indicates that device regards Password as Master Password. |
| Security Level | Zero indicates High level, one indicates Maximum level. If the host sets High level and the password is forgotten, then the Master Password can be used to unlock the device. If the host sets Maximum level and the user password is forgotten, only a Security Erase Prepare/Security Unit command can unlock the device and all data will be lost. |
| Password | The text of the password – all 32 bytes are always significant. |
| Master Password | The revision code field is returned in the IDENTIFY DEVICE word 92. |
| Revision Code | The valid revision codes are 0001h through FFFEh. The device accepts the command with a value of 0000h or FFFFh in this field, but does not change Master Password Revision code. |

The setting of the Identifier and Security level bits interact as follows.

Identifier=User / Security level = High

The password supplied with the command will be saved as the new user password. The security mode feature (lock function) will be enabled from the next power on. The file may then be unlocked by either the user password or the previously set master password.

Identifier=Master / Security level = High

This combination will set a master password but will NOT enable the security mode feature (lock function).

Identifier=User / Security level = Maximum

The password supplied with the command will be saved as the new user password. The security mode feature (lock function) will be enabled from the next power on. The file may then be unlocked by only the user password. The master password previously set is still stored in the file but may NOT be used to unlock the device.

Identifier=Master / Security level = Maximum

This combination will set a master password but will NOT enable the security mode feature (lock function).

11.43 Security Unlock (F2h)

| Command Block Output Registers | | | | | | | | |
|--------------------------------|---|---|---|---|---|---|---|---|
| Register | 7 | 6 | 5 | 4 | 3 | 2 | 1 | 0 |
| Data | - | - | - | - | - | - | - | - |
| Feature | - | - | - | - | - | - | - | - |
| Sector Count | - | - | - | - | - | - | - | - |
| Sector Number | - | - | - | - | - | - | - | - |
| Cylinder Low | - | - | - | - | - | - | - | - |
| Cylinder High | - | - | - | - | - | - | - | - |
| Device/Head | 1 | - | 1 | D | - | - | - | - |
| Command | 1 | 1 | 1 | 1 | 0 | 0 | 1 | 0 |

| Command Block Input Registers | | | | | | | | |
|-------------------------------|-----------------|---|---|---|---|---|---|---|
| Register | 7 | 6 | 5 | 4 | 3 | 2 | 1 | 0 |
| Data | - | - | - | - | - | - | - | - |
| Error | ...See Below... | | | | | | | |
| Sector Count | - | - | - | - | - | - | - | - |
| Sector Number | - | - | - | - | - | - | - | - |
| Cylinder Low | - | - | - | - | - | - | - | - |
| Cylinder High | - | - | - | - | - | - | - | - |
| Device/Head | - | - | - | - | - | - | - | - |
| Status | ...See Below... | | | | | | | |

| Error Register | | | | | | | |
|----------------|-----|---|-----|---|-----|-----|-----|
| 7 | 6 | 5 | 4 | 3 | 2 | 1 | 0 |
| CRC | UNC | 0 | IDN | 0 | ABT | TON | AMN |
| 0 | V | 0 | 0 | 0 | V | 0 | 0 |

| Status Register | | | | | | | |
|-----------------|-----|----|-----|-----|-----|-----|-----|
| 7 | 6 | 5 | 4 | 3 | 2 | 1 | 0 |
| BSY | RDY | DF | DSC | DRQ | COR | IDX | ERR |
| 0 | V | 0 | - | - | 0 | - | V |

Table 210 Security Unlock Command (F2h)

This command unlocks the password and causes the device to enter device unlock mode. If power on reset or hard reset is done without executing the Security Disable Password command after this command is completed, the device will be in device lock mode. The password has not been changed yet.

The Security Unlock command requests to transfer a single sector of data from the host including information specified in Table 210 on the page 256.

If the Identifier bit is set to master and the file is in high security mode then the password supplied will be compared with the stored master password. If the file is in maximum security mode then the security unlock will be rejected.

If the Identifier bit is set to user, then the file compares the supplied password with the stored user password.

If the password compare fails, then the device returns an abort error to the host and decrements the unlock attempt counter. This counter is initially set to 5 and is decremented for each password mismatch.

When security is disabled and the Identifier bit is set to User, then the device shall return command aborted.

When this counter reaches zero then all password protected commands are rejected until a hard reset or a power off.

| Word | Description |
|--------|---|
| 00 | Control word bit 0 : Identifier (1-Mater, 0-User) bit 1-15 : Reserved |
| 01-16 | Password (32 bytes) |
| 17-255 | Reserved |

Table 211 Security Unlock Information

Identifier Zero indicates that device regards Password as User Password. One indicates that device regards Password as Master Password.

The user can detect if the attempt to unlock the device has failed due to a mismatched password as this is the only reason that an abort error will be returned by the file AFTER the password information has been sent to the device. If an abort error is returned by the device BEFORE the password data has been sent to the file then another problem exists.

11.44 Seek (7xh)

| Command Block Output Registers | | | | | | | | |
|--------------------------------|---|---|---|---|---|---|---|---|
| Register | 7 | 6 | 5 | 4 | 3 | 2 | 1 | 0 |
| Data | - | - | - | - | - | - | - | - |
| Feature | - | - | - | - | - | - | - | - |
| Sector Count | - | - | - | - | - | - | - | - |
| Sector Number | V | V | V | V | V | V | V | V |
| Cylinder Low | V | V | V | V | V | V | V | V |
| Cylinder High | V | V | V | V | V | V | V | V |
| Device/Head | 1 | L | 1 | D | H | H | H | H |
| Command | 0 | 1 | 1 | 1 | - | - | - | - |

| Command Block Input Registers | | | | | | | | |
|-------------------------------|-----------------|---|---|---|---|---|---|---|
| Register | 7 | 6 | 5 | 4 | 3 | 2 | 1 | 0 |
| Data | - | - | - | - | - | - | - | - |
| Error | ...See Below... | | | | | | | |
| Sector Count | - | - | - | - | - | - | - | - |
| Sector Number | V | V | V | V | V | V | V | V |
| Cylinder Low | V | V | V | V | V | V | V | V |
| Cylinder High | V | V | V | V | V | V | V | V |
| Device/Head | - | - | - | - | H | H | H | H |
| Status | ...See Below... | | | | | | | |

| Error Register | | | | | | | |
|----------------|-----|---|-----|---|-----|-----|-----|
| 7 | 6 | 5 | 4 | 3 | 2 | 1 | 0 |
| CRC | UNC | 0 | IDN | 0 | ABT | TON | AMN |
| 0 | 0 | 0 | V | 0 | V | 0 | 0 |

| Status Register | | | | | | | |
|-----------------|-----|----|-----|-----|-----|-----|-----|
| 7 | 6 | 5 | 4 | 3 | 2 | 1 | 0 |
| BSY | RDY | DF | DSC | DRQ | COR | IDX | ERR |
| 0 | V | 0 | V | - | 0 | - | V |

Table 212 Seek Command (7xh)

The Seek command initiates a seek to the designated track and selects the designated head. The device need not be formatted for a seek to execute properly.

Output Parameters To The Device

Sector Number In LBA mode, this register specifies LBA address bits 0 – 7 for seek. (L=1)

Cylinder High/Low The cylinder number of the seek.
In LBA mode, this register specifies LBA address bits 8 – 15 (Low), 16 – 23 (High) for seek. (L=1)

H The head number of the seek.
In LBA mode, this register specifies LBA address bits 24 – 27 for seek. (L=1)

Input Parameters From The Device

Sector Number In LBA mode, this register contains current LBA bits 0 – 7. (L=1)

Cylinder High/Low In LBA mode, this register contains current LBA bits 8 – 15 (Low), 16 – 23 (High). (L=1)

H In LBA mode, this register contains current LBA bits 24 – 27. (L=1)

11.45 Sense Condition (F0h : Vendor-specific)

| Command Block Output Registers | | | | | | | | |
|--------------------------------|---|---|---|---|---|---|---|---|
| Register | 7 | 6 | 5 | 4 | 3 | 2 | 1 | 0 |
| Data | - | - | - | - | - | - | - | - |
| Feature | 0 | 0 | 0 | 0 | 0 | 0 | 0 | 1 |
| Sector Count | - | - | - | - | - | - | - | - |
| Sector Number | - | - | - | - | - | - | - | - |
| Cylinder Low | - | - | - | - | - | - | - | - |
| Cylinder High | - | - | - | - | - | - | - | - |
| Device/Head | - | - | - | - | - | - | - | - |
| Command | 1 | 1 | 1 | 1 | 0 | 0 | 0 | 0 |

| Command Block Input Registers | | | | | | | | |
|-------------------------------|-----------------|---|---|---|---|---|---|---|
| Register | 7 | 6 | 5 | 4 | 3 | 2 | 1 | 0 |
| Data | - | - | - | - | - | - | - | - |
| Error | ...See Below... | | | | | | | |
| Sector Count | V | V | V | V | V | V | V | V |
| Sector Number | - | - | - | - | - | - | - | - |
| Cylinder Low | - | - | - | - | - | - | - | - |
| Cylinder High | - | - | - | - | - | - | - | - |
| Device/Head | - | - | - | - | - | - | - | - |
| Status | ...See Below... | | | | | | | |

| Error Register | | | | | | | |
|----------------|-----|---|-----|---|-----|-----|-----|
| 7 | 6 | 5 | 4 | 3 | 2 | 1 | 0 |
| CRC | UNC | 0 | IDN | 0 | ABT | T0N | AMN |
| 0 | 0 | 0 | 0 | 0 | V | 0 | 0 |

| Status Register | | | | | | | |
|-----------------|-----|----|-----|-----|-----|-----|-----|
| 7 | 6 | 5 | 4 | 3 | 2 | 1 | 0 |
| BSY | RDY | DF | DSC | DRQ | COR | IDX | ERR |
| V | V | V | - | V | - | 0 | V |

Table 213 Sense Condition Command (F0h)

The Sense Condition command is used to sense temperature in a device.

This command is executable even if a device is in Power up in standby mode.

Output Parameters To The Device

Feature The Feature register must be set to 01h. All other value is rejected with setting ABORT bit in status register.

Input Parameters From The Device

Sector Count The Sector Count register contains result value.

| Value | Description |
|---------|---|
| 00h | Temperature is equal to or lower than -20 deg C |
| 01h-FEh | Temperature is (Value / 2 - 20) deg C |
| FFh | Temperature is higher than 107 deg C |

11.46 Set Features (EFh)

| Command Block Output Registers | | | | | | | | |
|--------------------------------|--------|---|---|---|---|---|---|---|
| Register | 7 | 6 | 5 | 4 | 3 | 2 | 1 | 0 |
| Data | - | - | - | - | - | - | - | - |
| Feature | V | V | V | V | V | V | V | V |
| Sector Count | Note.1 | | | | | | | |
| Sector Number | - | - | - | - | - | - | - | - |
| Cylinder Low | - | - | - | - | - | - | - | - |
| Cylinder High | - | - | - | - | - | - | - | - |
| Device/Head | 1 | - | 1 | D | - | - | - | - |
| Command | 1 | 1 | 1 | 0 | 1 | 1 | 1 | 1 |

| Command Block Input Registers | | | | | | | | |
|-------------------------------|-----------------|---|---|---|---|---|---|---|
| Register | 7 | 6 | 5 | 4 | 3 | 2 | 1 | 0 |
| Data | - | - | - | - | - | - | - | - |
| Error | ...See Below... | | | | | | | |
| Sector Count | - | - | - | - | - | - | - | - |
| Sector Number | - | - | - | - | - | - | - | - |
| Cylinder Low | - | - | - | - | - | - | - | - |
| Cylinder High | - | - | - | - | - | - | - | - |
| Device/Head | - | - | - | - | - | - | - | - |
| Status | ...See Below... | | | | | | | |

| Error Register | | | | | | | |
|----------------|-----|---|-----|---|-----|-----|-----|
| 7 | 6 | 5 | 4 | 3 | 2 | 1 | 0 |
| CRC | UNC | 0 | IDN | 0 | ABT | TON | AMN |
| 0 | 0 | 0 | 0 | 0 | V | 0 | 0 |

| Status Register | | | | | | | |
|-----------------|-----|----|-----|-----|-----|-----|-----|
| 7 | 6 | 5 | 4 | 3 | 2 | 1 | 0 |
| BSY | RDY | DF | DSC | DRQ | COR | IDX | ERR |
| 0 | V | 0 | - | - | 0 | - | V |

Table 214 Set Features Command (EFh)

The Set Feature command is to establish the following parameters which affect the execution of certain features as shown in below table.

ABT will be set to 1 in the Error Register if the Feature register contains any undefined values.

Output Parameters To The Device

| Feature | Destination code for this command |
|------------|---|
| 02H | Enable write cache |
| 03H | Set transfer mode based on value in sector count register |
| 05H | Enable Advanced Power Management |
| 06H | Enable Power-up in Standby feature set |
| 07H | Power-Up In Standby feature set device spin-up |
| 10H | Enable use of Serial ATA feature |
| 43H | Set Maximum Host Interface Sector Time |
| 4Ah | Extended Power Conditions |
| 55H | Disable read look-ahead feature |
| 66H | Disable reverting to power on defaults |
| 82H | Disable write cache |
| 85H | Disable Advanced Power Management |
| 86H | Disable Power-up in Standby mode |
| 90H | Disable use of Serial ATA feature |
| AAH | Enable read look-ahead feature |
| CCH | Enable reverting to power on defaults |

Note.

After power on reset or hard reset, the device is set to the following features as default.

| | |
|--------------------------------|-----------|
| Write cache | : Enable |
| Read look-ahead | : Enable |
| Reverting to power on defaults | : Disable |
| Release interrupt | : Disable |

11.46.1 Set Transfer Mode

When Feature register is 03h (=Set Transfer Mode), the Sector Count Register specifies the transfer mechanism. The upper 5 bits define the type of transfer and the low order 3 bits encode the mode value.

| | | | |
|----------------------------------|-------|-----|-----------------------------------|
| PIO Default Transfer Mode | 00000 | 000 | |
| PIO Default Transfer Mode | 00000 | 001 | |
| Disable IORDY | | | |
| PIO Flow Control Transfer Mode x | 00001 | nnn | (nnn=000,001,010,011,100) |
| Multiword DMA mode x | 00100 | nnn | (nnn=000,001,010) |
| Ultra DMA mode x | 01000 | nnn | (nnn=000,001,010,011,100,101,110) |

11.46.2 Write Cache

If the number of auto reassigned sector reaches the device's reassignment capacity, the write cache function will be automatically disabled. Although the device still accepts the Set Features command with Feature register = 02h without error, but the write cache function will remain disabled. For current write cache function status, please refer to Identify Device Information (word 85 or 129) by Identify Device command.

11.46.3 Serial ATA Feature

When the Feature register is set to 10h or 90h, the value set to the Sector Count register specifies the specific Serial ATA feature to enable or disable.

| Sector Count Value | Description |
|--------------------|--|
| 01h | Non-zero buffer offset in DMA Setup FIS |
| 02h | DMA Setup FIS Auto-Activate optimization |
| 03h | Device-initiated interface power state transitions |
| 04h | Guaranteed In-Order Data Delivery |
| 06h | Software Settings Preservation |

11.46.4 Advanced Power Management

When the value in the Feature register is 05h (=Enable Advanced Power Management), the Sector Count Register specifies the Advanced Power Management level.

| | |
|--------------|---|
| FFh --- | Aborted |
| C0 – FEh --- | The deepest power saving mode is Idle mode (the same as Disable Advanced Power Management) |
| 80 – BFh --- | The deepest power saving mode is Low power Idle mode |
| 01 – 7Fh --- | The deepest power saving mode is Low RPM Idle mode |
| 00h --- | Aborted |

The idle time to Low power idle mode and Low RPM idle mode vary according to the value in Sector Count Register as follows:

When Low power idle mode is the deepest power saving mode,

$$Y_1 = (x - 80h) * 5 + 120 \text{ [sec]} \quad (120 \leq Y_1 \leq 435)$$

$$Y_2 = \text{N/A (the device does not go to Low RPM idle mode)}$$

When Low RPM idle mode is the deepest power saving mode and the value in Sector Count Register is between 40h and 7Fh,

$$120 \leq Y_1 \leq 435 \text{ [sec]} \quad (\text{default: } 120 \text{ [sec]})$$

$$Y_2 = (x - 40h) * 60 + 600 \text{ [sec]} \quad (600 \leq Y_2 \leq 4380)$$

When Low RPM idle mode is the deepest power saving mode and the value in Sector Count Register is between 01h and 3Fh,

$$120 \leq Y_1 \leq 435 \text{ [sec]} \quad (\text{default: } 120 \text{ [sec]})$$

$$Y_2 = 600 \text{ [sec]}$$

Where x is the value in Sector Count Register, y_1 is the idle time to Low Power Idle mode, and y_2 is the idle time to Low RPM idle mode.

If Low power idle mode has already been enabled (i.e., y_1 has been set) before Low RPM idle mode is enabled, y_1 is preserved. If Low power idle mode is disabled (i.e., y_1 has not been set yet), y_1 becomes 120[sec] when Low RPM idle mode is enabled.

Enabled power saving mode and idle time (y_1 and y_2) are preserved until Advanced Power Management is disabled, the deepest power saving mode becomes Idle mode, or new time is set. They are initialized with a hard/soft reset unless Reverting to power on defaults is disabled and the device receives a soft reset.

11.46.5 Set Maximum Host Interface Sector Time

| | |
|--------------|--|
| Sector Count | Typical PIO Mode Host Interface Sector Time (7:0) |
| LBA Low | Typical PIO Mode Host Interface Sector Time (15:8) |
| LBA Mid | Typical DMA Mode Host Interface Sector Time (7:0) |
| LBA High | Typical DMA Mode Host Interface Sector Time (15:8) |

Subcommand code 43h allows the host to inform the device of a host interface rate limitation. The typical Host Interface Sector Times have the same units as Identify Device word 96 for DMA and word 104 for PIO. A value of zero indicates that the host interface shall be capable of transferring data at the maximum rate allowed by the selected transfer mode. The Typical PIO Mode Host Interface Sector Time includes the host's interrupt service time.

11.46.6 Extended Power Conditions (EPC) Feature

11.46.6.1 Restore Power Condition Settings Subcommand

| Command Block Output Registers | | | | | | | | | Command Block Input Registers | | | | | | | | |
|--------------------------------|---|---|---|---|---|---|---|---|-------------------------------|-----------------|---|---|---|---|---|---|---|
| Register | 7 | 6 | 5 | 4 | 3 | 2 | 1 | 0 | Register | 7 | 6 | 5 | 4 | 3 | 2 | 1 | 0 |
| Data | - | - | - | - | - | - | - | - | Data | - | - | - | - | - | - | - | - |
| Feature | 0 | 1 | 0 | 0 | 1 | 0 | 1 | 0 | Error | ...See Below... | | | | | | | |
| Sector Count | V | V | V | V | V | V | V | V | Sector Count | - | - | - | - | - | - | - | - |
| Sector Number | - | V | - | V | 0 | 0 | 0 | 0 | Sector Number | - | - | - | - | - | - | - | - |
| Cylinder Low | - | - | - | - | - | - | - | - | Cylinder Low | - | - | - | - | - | - | - | - |
| Cylinder High | - | - | - | - | - | - | - | - | Cylinder High | - | - | - | - | - | - | - | - |
| Device/Head | 1 | - | 1 | D | - | - | - | - | Device/Head | - | - | - | - | - | - | - | - |
| Command | 1 | 1 | 1 | 0 | 1 | 1 | 1 | 1 | Status | ...See Below... | | | | | | | |

| Error Register | | | | | | | | Status Register | | | | | | | |
|----------------|-----|---|-----|---|-----|-----|-----|-----------------|-----|----|-----|-----|-----|-----|-----|
| 7 | 6 | 5 | 4 | 3 | 2 | 1 | 0 | 7 | 6 | 5 | 4 | 3 | 2 | 1 | 0 |
| CRC | UNC | 0 | IDN | 0 | ABT | TON | AMN | BSY | RDY | DF | DSC | DRQ | COR | IDX | ERR |
| 0 | 0 | 0 | 0 | 0 | V | 0 | 0 | 0 | V | 0 | - | - | 0 | - | V |

Table 215 Restore Power Condition Settings Subcommand

On successful completion of this EPC subcommand, the device updates the Power Conditions log for the selected Power Condition ID as follows:

- 1) if Default is set to one, then:
 - A) copy the Default Timer Settings field to the Current Timer Settings field; and
 - B) copy the Default Timer Enabled field to the Current Timer Enabled field;
 - 2) if Default is cleared to zero, then:
 - A) copy the Saved Timer Settings field to the Current Timer Settings field; and
 - B) copy the Saved Timer Enabled field to the Current Timer Enabled field;
- and
- 3) if Save is set to one and the power condition is savable, then:
 - A) copy the Current Timer Settings field to the Saved Timer Settings field;

Output Parameters To The Device

Sector Count Power Condition ID (See Table 74)

| Sector Number | bit | Description |
|---------------|-----|--|
| | 7 | Reserved |
| | 6 | Default |
| | 1 | Restore from Default settings |
| | 0 | Restore from Saved settings |
| | 5 | Reserved |
| | 4 | Save |
| | 1 | Save settings on completion |
| | 0 | Do not save settings on completion |
| 3-0 | | 0h Restore Power Condition subcommand (See Table 73) |

Error Output

If any selected Power Condition is not supported, or is not changeable, or if Extended Power Condition feature set is disable, or if Save is set to one and any selected power condition is not savable, then the device returns command aborted .

11.46.6.2 Go To Power Condition Subcommand

| Command Block Output Registers | | | | | | | | |
|--------------------------------|---|---|---|---|---|---|---|---|
| Register | 7 | 6 | 5 | 4 | 3 | 2 | 1 | 0 |
| Data | - | - | - | - | - | - | - | - |
| Feature | 0 | 1 | 0 | 0 | 1 | 0 | 1 | 0 |
| Sector Count | V | V | V | V | V | V | V | V |
| Sector Number | - | - | - | - | 0 | 0 | 0 | 1 |
| Cylinder Low | - | - | - | - | - | - | - | - |
| Cylinder High | - | - | - | - | - | - | - | - |
| Device/Head | 1 | - | 1 | D | - | - | - | - |
| Command | 1 | 1 | 1 | 0 | 1 | 1 | 1 | 1 |

| Command Block Input Registers | | | | | | | | |
|-------------------------------|------------------|---|---|---|---|---|---|---|
| Register | 7 | 6 | 5 | 4 | 3 | 2 | 1 | 0 |
| Data | - | - | - | - | - | - | - | - |
| Error | ... See Below... | | | | | | | |
| Sector Count | - | - | - | - | - | - | - | - |
| Sector Number | - | - | - | - | - | - | - | - |
| Cylinder Low | - | - | - | - | - | - | - | - |
| Cylinder High | - | - | - | - | - | - | - | - |
| Device/Head | - | - | - | - | - | - | - | - |
| Status | ... See Below... | | | | | | | |

| Error Register | | | | | | | |
|----------------|-----|---|-----|---|-----|-----|-----|
| 7 | 6 | 5 | 4 | 3 | 2 | 1 | 0 |
| CRC | UNC | 0 | IDN | 0 | ABT | T0N | AMN |
| 0 | 0 | 0 | 0 | 0 | V | 0 | 0 |

| Status Register | | | | | | | |
|-----------------|-----|----|-----|-----|-----|-----|-----|
| 7 | 6 | 5 | 4 | 3 | 2 | 1 | 0 |
| BSY | RDY | DF | DSC | DRQ | COR | IDX | ERR |
| 0 | V | 0 | - | - | 0 | - | V |

Table 216 Go To Power Condition Subcommand

On successful completion of this EPC subcommand, the device:

- 1) stops all enabled EPC timers;
- 2) enters the selected EPC power condition after command completion of the SET FEATURES command without having to wait for any timers to expire; and
- 3) the device remains in the selected power condition until the device processes the next command or reset.

Output Parameters To The Device

Sector Count Power Condition ID (See Table 74)

Sector Number bit Description

7-4 Reserved

3-0 1h Go To Power Condition subcommand (See Table 73)

Error Output

If the Power condition ID is FFh, a reserved value, or is not supported, or if Extended Power Condition feature set is disable, then the device returns command aborted .

11.46.6.3 Set Power Condition Timer Subcommand

| Command Block Output Registers | | | | | | | | |
|--------------------------------|---|---|---|---|---|---|---|---|
| Register | 7 | 6 | 5 | 4 | 3 | 2 | 1 | 0 |
| Data | - | - | - | - | - | - | - | - |
| Feature | 0 | 1 | 0 | 0 | 1 | 0 | 1 | 0 |
| Sector Count | V | V | V | V | V | V | V | V |
| Sector Number | V | - | V | V | 0 | 0 | 1 | 0 |
| Cylinder Low | V | V | V | V | V | V | V | V |
| Cylinder High | V | V | V | V | V | V | V | V |
| Device/Head | 1 | - | 1 | D | - | - | - | - |
| Command | 1 | 1 | 1 | 0 | 1 | 1 | 1 | 1 |

| Command Block Input Registers | | | | | | | | |
|-------------------------------|-----------------|---|---|---|---|---|---|---|
| Register | 7 | 6 | 5 | 4 | 3 | 2 | 1 | 0 |
| Data | - | - | - | - | - | - | - | - |
| Error | ...See Below... | | | | | | | |
| Sector Count | - | - | - | - | - | - | - | - |
| Sector Number | - | - | - | - | - | - | - | - |
| Cylinder Low | - | - | - | - | - | - | - | - |
| Cylinder High | - | - | - | - | - | - | - | - |
| Device/Head | - | - | - | - | - | - | - | - |
| Status | ...See Below... | | | | | | | |

| Error Register | | | | | | | |
|----------------|-----|---|-----|---|-----|-----|-----|
| 7 | 6 | 5 | 4 | 3 | 2 | 1 | 0 |
| CRC | UNC | 0 | IDN | 0 | ABT | T0N | AMN |
| 0 | 0 | 0 | 0 | 0 | V | 0 | 0 |

| Status Register | | | | | | | |
|-----------------|-----|----|-----|-----|-----|-----|-----|
| 7 | 6 | 5 | 4 | 3 | 2 | 1 | 0 |
| BSY | RDY | DF | DSC | DRQ | COR | IDX | ERR |
| 0 | V | 0 | - | - | 0 | - | V |

Table 217 Set Power Condition Timer Subcommand

On successful completion of this EPC subcommand, the device updates the Power Conditions log for the selected and supported Power Condition as follows:

- 1) copy the Timer field to the Current Timer Settings field;
- 2) if Enable is set to one and the Timer field is non-zero, then enable the Current Timer;
- 3) if Enable is set to one and the Timer field is zero, then disable the Current Timer;
- 4) if Enable is cleared to zero, then disable the Current Timer; and
- 5) if Save is set to one and the Power Condition settings are savable, then:
 - A) copy the Current Timer Settings field to the Saved Timer Settings field; and
 - B) copy the Current Timer Enabled field to the Saved Timer Enabled field.

Output Parameters To The Device

Sector Count Power Condition ID (See Table 74)

| Sector Number | bit | Description |
|---------------|-----|-------------|
|---------------|-----|-------------|

| | |
|---|-------------|
| 7 | Timer Units |
|---|-------------|

If the Timer Units bit is cleared to zero, then the Timer (Cylinder High and Cylinder Low bit 15-0) are specified in units of 100 milliseconds. If the Timer Units bit is set to one, then the Timer (Cylinder High and Cylinder Low bit 15-0) are specified in units of 1 minute.

| | |
|---|----------|
| 6 | Reserved |
|---|----------|

| | |
|---|--------|
| 5 | Enable |
|---|--------|

| | |
|---|-------------------------------------|
| 1 | Enable the selected power condition |
|---|-------------------------------------|

| | |
|---|--------------------------------------|
| 0 | Disable the selected power condition |
|---|--------------------------------------|

| | |
|---|------|
| 4 | Save |
|---|------|

| | |
|---|-----------------------------|
| 1 | Save settings on completion |
|---|-----------------------------|

| | |
|---|------------------------------------|
| 0 | Do not save settings on completion |
|---|------------------------------------|

3-0 2h Set Power Condition Timer subcommand (See Table 73)

| | |
|----------------------|--|
| Cylinder Low | 15-0 If the new timer value is greater than the maximum value setting, then the device set the value to the maximum setting. If the new timer value is less than the minimum setting, then the device set the value to the minimum setting. |
| Cylinder High | (Cylinder High and Cylinder Low bit 15-0) |

Error Output

The device returns command aborted, If:

- a) the new timer value is:
 - A) less than the maximum setting.
 - B) greater than the minimum setting.
 - C) not supported by the device.
- b) the Extended Power Condition feature set is disabling.
- c) the power condition is not changeable or not supported.
- d) the Save bit is set to one and the selected power condition is not savable.
- e) the new time value is greater than the maximum setting and the device did not set the timer to the maximum setting.
- f) the new time value is less than the minimum setting and the device did not set the timer to the minimum setting.

If command aborted is returned, then the device makes no modifications to the power condition settings.

Maximum Setting is 3BFFC4h (100ms unit). Minimum Setting is zero.

11.46.6.4 Set Power Condition State Subcommand

| Command Block Output Registers | | | | | | | | |
|--------------------------------|---|---|---|---|---|---|---|---|
| Register | 7 | 6 | 5 | 4 | 3 | 2 | 1 | 0 |
| Data | - | - | - | - | - | - | - | - |
| Feature | 0 | 1 | 0 | 0 | 1 | 0 | 1 | 0 |
| Sector Count | V | V | V | V | V | V | V | V |
| Sector Number | - | - | V | V | 0 | 0 | 1 | 1 |
| Cylinder Low | - | - | - | - | - | - | - | - |
| Cylinder High | - | - | - | - | - | - | - | - |
| Device/Head | 1 | - | 1 | D | - | - | - | - |
| Command | 1 | 1 | 1 | 0 | 1 | 1 | 1 | 1 |

| Command Block Input Registers | | | | | | | | |
|-------------------------------|-----------------|---|---|---|---|---|---|---|
| Register | 7 | 6 | 5 | 4 | 3 | 2 | 1 | 0 |
| Data | - | - | - | - | - | - | - | - |
| Error | ...See Below... | | | | | | | |
| Sector Count | - | - | - | - | - | - | - | - |
| Sector Number | - | - | - | - | - | - | - | - |
| Cylinder Low | - | - | - | - | - | - | - | - |
| Cylinder High | - | - | - | - | - | - | - | - |
| Device/Head | - | - | - | - | - | - | - | - |
| Status | ...See Below... | | | | | | | |

| Error Register | | | | | | | |
|----------------|-----|---|-----|---|-----|-----|-----|
| 7 | 6 | 5 | 4 | 3 | 2 | 1 | 0 |
| CRC | UNC | 0 | IDN | 0 | ABT | T0N | AMN |
| 0 | 0 | 0 | 0 | 0 | V | 0 | 0 |

| Status Register | | | | | | | |
|-----------------|-----|----|-----|-----|-----|-----|-----|
| 7 | 6 | 5 | 4 | 3 | 2 | 1 | 0 |
| BSY | RDY | DF | DSC | DRQ | COR | IDX | ERR |
| 0 | V | 0 | - | - | 0 | - | V |

Table 218 Set Power Condition State Subcommand

On successful completion of this EPC subcommand, the device updates the Power Conditions log for the Power Condition as follows:

- 1) If the Enable bit is set to one, then enable the Current Timer; otherwise disable the Current Timer; and
- 2) If the Save bit is set to one, then copy the Current Timer Enabled field to the Saved Timer Enabled field.

Output Parameters To The Device

Sector Count Power Condition ID (See Table 74)

Sector Number bit Description

7-6 Reserved

5 Enable

1 Enable the selected power condition

0 Disable the selected power condition

4 Save

1 Save settings on completion

0 Do not save settings on completion

3-0 3h Set Power Condition State subcommand (See Table 73)

Error Output

If the Power Condition is not changeable, or not supported, or if Extended Power Conditions feature set is disabling, then the device returns command aborted. If the Save bit is set to one and the selected power condition is not savable, then the device returns command aborted. If command aborted is returned, then the device makes no modifications to the power condition settings.

11.46.6.5 Enable the EPC Feature Subcommand

| Command Block Output Registers | | | | | | | | |
|--------------------------------|---|---|---|---|---|---|---|---|
| Register | 7 | 6 | 5 | 4 | 3 | 2 | 1 | 0 |
| Data | - | - | - | - | - | - | - | - |
| Feature | 0 | 1 | 0 | 0 | 1 | 0 | 1 | 0 |
| Sector Count | - | - | - | - | - | - | - | - |
| Sector Number | - | - | - | - | 0 | 1 | 0 | 0 |
| Cylinder Low | - | - | - | - | - | - | - | - |
| Cylinder High | - | - | - | - | - | - | - | - |
| Device/Head | 1 | - | 1 | D | - | - | - | - |
| Command | 1 | 1 | 1 | 0 | 1 | 1 | 1 | 1 |

| Command Block Input Registers | | | | | | | | |
|-------------------------------|-----------------|---|---|---|---|---|---|---|
| Register | 7 | 6 | 5 | 4 | 3 | 2 | 1 | 0 |
| Data | - | - | - | - | - | - | - | - |
| Error | ...See Below... | | | | | | | |
| Sector Count | - | - | - | - | - | - | - | - |
| Sector Number | - | - | - | - | - | - | - | - |
| Cylinder Low | - | - | - | - | - | - | - | - |
| Cylinder High | - | - | - | - | - | - | - | - |
| Device/Head | - | - | - | - | - | - | - | - |
| Status | ...See Below... | | | | | | | |

| Error Register | | | | | | | |
|----------------|-----|---|-----|---|-----|-----|-----|
| 7 | 6 | 5 | 4 | 3 | 2 | 1 | 0 |
| CRC | UNC | 0 | IDN | 0 | ABT | T0N | AMN |
| 0 | 0 | 0 | 0 | 0 | V | 0 | 0 |

| Status Register | | | | | | | |
|-----------------|-----|----|-----|-----|-----|-----|-----|
| 7 | 6 | 5 | 4 | 3 | 2 | 1 | 0 |
| BSY | RDY | DF | DSC | DRQ | COR | IDX | ERR |
| 0 | V | 0 | - | - | 0 | - | V |

Table 219 Enable the EPC Feature Subcommand

On successful completion of this EPC subcommand, the device:

- enables the EPC feature set;
- sets IDENTIFY DEVICE data word 120 bit 7 to one; and
- disables the APM feature set.
- if the Saved Timer Setting field is cleared to zero, then:
copy the value of the Default Timer Setting to the Current Timer Setting; and
- if the Saved Timer Setting field is non-zero, then:
copy the value of the Saved Timer Setting to the Current Timer Setting; and
- if the Current Timer Setting field is non-zero and the Current Timer Enabled is set to one,
then initialize and start the timer.

If the EPC feature set is enabled, then the EPC feature set remains enabled across all resets (i.e., power-on reset, hardware reset, and software reset).

Output Parameters To The Device

Sector Number bit Description

7-4 Reserved

3-0 4h Enable the EPC feature subcommand (See Table 73)

Error Output

If the Extended Power Condition feature set is not supported then the device returns command aborted.

11.46.6.6 Disable the EPC Feature Subcommand

| Command Block Output Registers | | | | | | | | |
|--------------------------------|---|---|---|---|---|---|---|---|
| Register | 7 | 6 | 5 | 4 | 3 | 2 | 1 | 0 |
| Data | - | - | - | - | - | - | - | - |
| Feature | 0 | 1 | 0 | 0 | 1 | 0 | 1 | 0 |
| Sector Count | - | - | - | - | - | - | - | - |
| Sector Number | - | - | - | - | 0 | 1 | 0 | 1 |
| Cylinder Low | - | - | - | - | - | - | - | - |
| Cylinder High | - | - | - | - | - | - | - | - |
| Device/Head | 1 | - | 1 | D | - | - | - | - |
| Command | 1 | 1 | 1 | 0 | 1 | 1 | 1 | 1 |

| Command Block Input Registers | | | | | | | | |
|-------------------------------|-----------------|---|---|---|---|---|---|---|
| Register | 7 | 6 | 5 | 4 | 3 | 2 | 1 | 0 |
| Data | - | - | - | - | - | - | - | - |
| Error | ...See Below... | | | | | | | |
| Sector Count | - | - | - | - | - | - | - | - |
| Sector Number | - | - | - | - | - | - | - | - |
| Cylinder Low | - | - | - | - | - | - | - | - |
| Cylinder High | - | - | - | - | - | - | - | - |
| Device/Head | - | - | - | - | - | - | - | - |
| Status | ...See Below... | | | | | | | |

| Error Register | | | | | | | |
|----------------|-----|---|-----|---|-----|-----|-----|
| 7 | 6 | 5 | 4 | 3 | 2 | 1 | 0 |
| CRC | UNC | 0 | IDN | 0 | ABT | TON | AMN |
| 0 | 0 | 0 | 0 | 0 | V | 0 | 0 |

| Status Register | | | | | | | |
|-----------------|-----|----|-----|-----|-----|-----|-----|
| 7 | 6 | 5 | 4 | 3 | 2 | 1 | 0 |
| BSY | RDY | DF | DSC | DRQ | COR | IDX | ERR |
| 0 | V | 0 | - | - | 0 | - | V |

Table 220 Disable the EPC feature subcommand

On successful completion of this EPC subcommand, the device:

- a) stop all EPC timers
- b) disables the EPC feature set; and
- c) clears IDENTIFY DEVICE data word 120 bit 7 to zero.

If the EPC feature set is disabled, then the EPC feature set remains disabled across all resets (i.e., power-on reset, hardware reset, and software reset).

Output Parameters To The Device

| Sector Number | bit | Description |
|---------------|-----|--|
| | 7-4 | Reserved |
| | 3-0 | 5h Disable the EPC feature subcommand (See Table 73) |

Error Output

If the Extended Power Condition feature set is disabling, not supported then the device returns command aborted.

11.47 Set Max Address (F9h)

| Command Block Output Registers | | | | | | | | |
|--------------------------------|---|---|---|---|---|---|---|---|
| Register | 7 | 6 | 5 | 4 | 3 | 2 | 1 | 0 |
| Data | - | - | - | - | - | - | - | - |
| Feature | V | V | V | V | V | V | V | V |
| Sector Count | - | - | - | - | - | - | - | B |
| Sector Number | V | V | V | V | V | V | V | V |
| Cylinder Low | V | V | V | V | V | V | V | V |
| Cylinder High | V | V | V | V | V | V | V | V |
| Device/Head | 1 | L | 1 | D | H | H | H | H |
| Command | 1 | 1 | 1 | 1 | 1 | 0 | 0 | 1 |

| Command Block Input Registers | | | | | | | | |
|-------------------------------|-----------------|---|---|---|---|---|---|---|
| Register | 7 | 6 | 5 | 4 | 3 | 2 | 1 | 0 |
| Data | - | - | - | - | - | - | - | - |
| Error | ...See Below... | | | | | | | |
| Sector Count | - | - | - | - | - | - | - | - |
| Sector Number | V | V | V | V | V | V | V | V |
| Cylinder Low | V | V | V | V | V | V | V | V |
| Cylinder High | V | V | V | V | V | V | V | V |
| Device/Head | - | - | - | - | H | H | H | H |
| Status | ...See Below... | | | | | | | |

| Error Register | | | | | | | |
|----------------|-----|---|-----|---|-----|-----|-----|
| 7 | 6 | 5 | 4 | 3 | 2 | 1 | 0 |
| CRC | UNC | 0 | IDN | 0 | ABT | T0N | AMN |
| 0 | 0 | 0 | 0 | 0 | V | 0 | 0 |

| Status Register | | | | | | | |
|-----------------|-----|----|-----|-----|-----|-----|-----|
| 7 | 6 | 5 | 4 | 3 | 2 | 1 | 0 |
| BSY | RDY | DF | DSC | DRQ | COR | IDX | ERR |
| 0 | V | 0 | - | - | 0 | - | V |

Table 221 Set Max ADDRESS (F9h)

The device regards as Set Max Address command, if this command is immediately preceded by a Read Native Max Address command. The device receives this command without a prior Read Native Max Address command, the device regards as Set Max security extensions command according to feature register value. Valid features values are as follows:

1. 01h indicates Set Max Set Password command
2. 02h indicates Set Max Lock command
3. 03h indicates Set Max Unlock command
4. 04h indicates Set Max Freeze LOCK command

This command overwrites the maximum number of Address of HDD in a range of actual device capacity. Once device receives this command, all accesses beyond that Address are rejected with setting ABORT bit in status register. Identify device command returns the Address which is set via this command as a default value.

Device returns command aborted for a second non-volatile Set Max Address command until next power on or hardware reset.

Device returns command aborted during Set Max Locked mode or Set Max Frozen mode.

After a successful command completion, Identify Device response words (61:60) shall reflect the maximum address set with this command.

If the 48-bit Address feature set is supported, the value placed in Identify Device response words (103:100) shall be the same as the value placed in words (61:60). However, if the device contains greater than 268,435,455 sectors, the capacity addressable with 28-bit commands, and the address requested is 268,435,455, the max address shall be changed to the native maximum address, the value placed in words (61:60) shall be 268,435,455 and the value placed in words (103:100) shall be the native maximum address.

If a host protected area has been established by a Set Max Address Ext command, the device shall return command aborted.

Output Parameters To The Device

B Option bit for selection whether nonvolatile or volatile. B=0 is volatile condition. When B=1, MAX Address which is set by Set Max Address command is preserved by POR. When B=0, MAX Address which is set by Set Max Address command will be lost by POR. B=1 is not valid when the device is in Address Offset mode.

Sector Number In LBA mode, this register contains LBA bits 0 – 7 which is to be input.(L=1)
In CHS mode, this register is ignored. (L=0)

Cylinder High/Low In LBA mode, this register contains LBA bits 8 – 15 (Low), 16 – 23 (High) which is to be set. (L=1)
In CHS mode, this register contains cylinder number which is to be set.(L=0)

H In LBA mode, this register contains LBA bits 24 – 27 which is to be set.(L=1)
In CHS mode, this register is ignored. (L=0)

Input Parameters From The Device

Sector Number In LBA mode, this register contains max LBA bits 0 – 7 which is set.(L=1)
In CHS mode, this register contains max sector number (= 63). (L=0)

Cylinder High/Low In LBA mode, this register contains max LBA bits 8 – 15 (Low), 16 – 23 (High) which is set. (L=1)
In CHS mode, this register contains max cylinder number which is set. (L=0)

H In LBA mode, this register contains max LBA bits 24 – 27 which is set. (L=1)
In CHS mode, this register contains max head number.(L=0)

11.47.1 Set Max Set Password (Feature = 01h)

| Command Block Output Registers | | | | | | | | |
|--------------------------------|---|---|---|---|---|---|---|---|
| Register | 7 | 6 | 5 | 4 | 3 | 2 | 1 | 0 |
| Data | - | - | - | - | - | - | - | - |
| Feature | 0 | 0 | 0 | 0 | 0 | 0 | 0 | 1 |
| Sector Count | - | - | - | - | - | - | - | - |
| Sector Number | - | - | - | - | - | - | - | - |
| Cylinder Low | - | - | - | - | - | - | - | - |
| Cylinder High | - | - | - | - | - | - | - | - |
| Device/Head | 1 | - | 1 | D | - | - | - | - |
| Command | 1 | 1 | 1 | 1 | 1 | 0 | 0 | 1 |

| Command Block Input Registers | | | | | | | | |
|-------------------------------|-----------------|---|---|---|---|---|---|---|
| Register | 7 | 6 | 5 | 4 | 3 | 2 | 1 | 0 |
| Data | - | - | - | - | - | - | - | - |
| Error | ...See Below... | | | | | | | |
| Sector Count | - | - | - | - | - | - | - | - |
| Sector Number | - | - | - | - | - | - | - | - |
| Cylinder Low | - | - | - | - | - | - | - | - |
| Cylinder High | - | - | - | - | - | - | - | - |
| Device/Head | 1 | - | 1 | D | - | - | - | - |
| Status | ...See Below... | | | | | | | |

| Error Register | | | | | | | |
|----------------|-----|---|-----|---|-----|-----|-----|
| 7 | 6 | 5 | 4 | 3 | 2 | 1 | 0 |
| CRC | UNC | 0 | IDN | 0 | ABT | T0N | AMN |
| 0 | 0 | 0 | 0 | 0 | V | 0 | 0 |

| Status Register | | | | | | | |
|-----------------|-----|----|-----|-----|-----|-----|-----|
| 7 | 6 | 5 | 4 | 3 | 2 | 1 | 0 |
| BSY | RDY | DF | DSC | DRQ | COR | IDX | ERR |
| 0 | V | 0 | - | - | 0 | - | V |

Table 222 Set Max Set Password

The device regards as Set Max Address command, if this command is immediately preceded by a Read Native Max Address command.

This command requests a transfer of a single sector of data from the host including the information specified in Table 222.

The password is retained by the device until the next power cycle. When the device accepts this command the device is in Set_Max_Unlocked state.

| Word | Description |
|--------|--------------------|
| 0 | Reserved |
| 01-16 | Password (32 byte) |
| 17-255 | Reserved |

Table 223 Set Max Set Password data contents

11.47.2 Set Max Lock (Feature = 02h)

| Command Block Output Registers | | | | | | | | |
|--------------------------------|---|---|---|---|---|---|---|---|
| Register | 7 | 6 | 5 | 4 | 3 | 2 | 1 | 0 |
| Data | - | - | - | - | - | - | - | - |
| Feature | 0 | 0 | 0 | 0 | 0 | 0 | 1 | 0 |
| Sector Count | - | - | - | - | - | - | - | - |
| Sector Number | - | - | - | - | - | - | - | - |
| Cylinder Low | - | - | - | - | - | - | - | - |
| Cylinder High | - | - | - | - | - | - | - | - |
| Device/Head | 1 | - | 1 | D | - | - | - | - |
| Command | 1 | 1 | 1 | 1 | 1 | 0 | 0 | 1 |

| Command Block Input Registers | | | | | | | | |
|-------------------------------|-----------------|---|---|---|---|---|---|---|
| Register | 7 | 6 | 5 | 4 | 3 | 2 | 1 | 0 |
| Data | - | - | - | - | - | - | - | - |
| Error | ...See Below... | | | | | | | |
| Sector Count | - | - | - | - | - | - | - | - |
| Sector Number | - | - | - | - | - | - | - | - |
| Cylinder Low | - | - | - | - | - | - | - | - |
| Cylinder High | - | - | - | - | - | - | - | - |
| Device/Head | 1 | - | 1 | D | - | - | - | - |
| Status | ...See Below... | | | | | | | |

| Error Register | | | | | | | |
|----------------|-----|---|-----|---|-----|-----|-----|
| 7 | 6 | 5 | 4 | 3 | 2 | 1 | 0 |
| CRC | UNC | 0 | IDN | 0 | ABT | T0N | AMN |
| 0 | 0 | 0 | 0 | 0 | V | 0 | 0 |

| Status Register | | | | | | | |
|-----------------|-----|----|-----|-----|-----|-----|-----|
| 7 | 6 | 5 | 4 | 3 | 2 | 1 | 0 |
| BSY | RDY | DF | DSC | DRQ | COR | IDX | ERR |
| 0 | V | 0 | - | - | 0 | - | V |

Table 224 Set Max Lock

The device regards as Set Max Address command, if this command is immediately preceded by a Read Native Max Address command.

This command sets the device into Set_Max_Locked state. After this command is completed any other Set Max commands except Set Max Unlock and Set Max Freeze Lock are rejected. The device remains in this state until a power cycle or the acceptance of a Set Max Unlock or Set Max Freeze Lock command.

11.47.3 Set Max Unlock (Feature = 03h)

| Command Block Output Registers | | | | | | | | |
|--------------------------------|---|---|---|---|---|---|---|---|
| Register | 7 | 6 | 5 | 4 | 3 | 2 | 1 | 0 |
| Data | - | - | - | - | - | - | - | - |
| Feature | 0 | 0 | 0 | 0 | 0 | 0 | 1 | 1 |
| Sector Count | - | - | - | - | - | - | - | - |
| Sector Number | - | - | - | - | - | - | - | - |
| Cylinder Low | - | - | - | - | - | - | - | - |
| Cylinder High | - | - | - | - | - | - | - | - |
| Device/Head | 1 | - | 1 | D | - | - | - | - |
| Command | 1 | 1 | 1 | 1 | 1 | 0 | 0 | 1 |

| Command Block Input Registers | | | | | | | | |
|-------------------------------|------------------|---|---|---|---|---|---|---|
| Register | 7 | 6 | 5 | 4 | 3 | 2 | 1 | 0 |
| Data | - | - | - | - | - | - | - | - |
| Error | ... See Below... | | | | | | | |
| Sector Count | - | - | - | - | - | - | - | - |
| Sector Number | - | - | - | - | - | - | - | - |
| Cylinder Low | - | - | - | - | - | - | - | - |
| Cylinder High | - | - | - | - | - | - | - | - |
| Device/Head | 1 | - | 1 | D | - | - | - | - |
| Status | ... See Below... | | | | | | | |

| Error Register | | | | | | | |
|----------------|-----|---|-----|---|-----|-----|-----|
| 7 | 6 | 5 | 4 | 3 | 2 | 1 | 0 |
| CRC | UNC | 0 | IDN | 0 | ABT | T0N | AMN |
| 0 | 0 | 0 | 0 | 0 | V | 0 | 0 |

| Status Register | | | | | | | |
|-----------------|-----|----|-----|-----|-----|-----|-----|
| 7 | 6 | 5 | 4 | 3 | 2 | 1 | 0 |
| BSY | RDY | DF | DSC | DRQ | COR | IDX | ERR |
| 0 | V | 0 | - | - | 0 | - | V |

Table 225 Set Max Unlock (F9h)

The device regards as Set Max Address command, if this command is immediately preceded by a Read Native Max Address command.

This command requests a transfer of a single sector of data from the host including the information specified in Table 222 on the page 271 with the stored SET MAX password.

If the password compare fails then the device returns an abort error to the host and decrements the unlock attempt counter. This counter is initially set to 5 and is decremented for each password mismatch. When this counter reaches zero then all Set Max Unlock commands are rejected until a hard reset or a power off.

If the password compares matches, then the device set the Set_Max_Unlocked state and all Set Max commands shall be accepted.

11.47.4 Set Max Freeze Lock (Feature = 04h)

| Command Block Output Registers | | | | | | | | |
|--------------------------------|---|---|---|---|---|---|---|---|
| Register | 7 | 6 | 5 | 4 | 3 | 2 | 1 | 0 |
| Data | - | - | - | - | - | - | - | - |
| Feature | 0 | 0 | 0 | 0 | 0 | 1 | 0 | 0 |
| Sector Count | - | - | - | - | - | - | - | - |
| Sector Number | - | - | - | - | - | - | - | - |
| Cylinder Low | - | - | - | - | - | - | - | - |
| Cylinder High | - | - | - | - | - | - | - | - |
| Device/Head | 1 | - | 1 | D | - | - | - | - |
| Command | 1 | 1 | 1 | 1 | 1 | 0 | 0 | 1 |

| Command Block Input Registers | | | | | | | | |
|-------------------------------|-----------------|---|---|---|---|---|---|---|
| Register | 7 | 6 | 5 | 4 | 3 | 2 | 1 | 0 |
| Data | - | - | - | - | - | - | - | - |
| Error | ...See Below... | | | | | | | |
| Sector Count | - | - | - | - | - | - | - | - |
| Sector Number | - | - | - | - | - | - | - | - |
| Cylinder Low | - | - | - | - | - | - | - | - |
| Cylinder High | - | - | - | - | - | - | - | - |
| Device/Head | 1 | - | 1 | D | - | - | - | - |
| Status | ...See Below... | | | | | | | |

| Error Register | | | | | | | |
|----------------|-----|---|-----|---|-----|-----|-----|
| 7 | 6 | 5 | 4 | 3 | 2 | 1 | 0 |
| CRC | UNC | 0 | IDN | 0 | ABT | T0N | AMN |
| 0 | 0 | 0 | 0 | 0 | V | 0 | 0 |

| Status Register | | | | | | | |
|-----------------|-----|----|-----|-----|-----|-----|-----|
| 7 | 6 | 5 | 4 | 3 | 2 | 1 | 0 |
| BSY | RDY | DF | DSC | DRQ | COR | IDX | ERR |
| 0 | V | 0 | - | - | 0 | - | V |

Table 226 Set Max Freeze Lock (F9h)

The device regards as Set Max Address command, if this command is immediately preceded by a Read Native Max Address command.

The Set Max Freeze Lock command sets the device to Set_Max_Frozen state. After command completion any subsequent Set Max commands are rejected. Commands disabled by Set Max Freeze Lock are:

1. Set Max Address
2. Set Max Set PASSWORD
3. Set Max Lock
4. Set Max Unlock

11.48 Set Max Address Ext (37h)

| Command Block Output Registers | | | | | | | | |
|--------------------------------|----------|---|---|---|---|---|---|---|
| Register | 7 | 6 | 5 | 4 | 3 | 2 | 1 | 0 |
| Data Low | - | - | - | - | - | - | - | - |
| Data High | - | - | - | - | - | - | - | - |
| Feature | Current | - | - | - | - | - | - | - |
| | Previous | - | - | - | - | - | - | - |
| Sector Count | Current | - | - | - | - | - | - | B |
| | Previous | - | - | - | - | - | - | - |
| Sector Number | Current | V | V | V | V | V | V | V |
| | Previous | V | V | V | V | V | V | V |
| Cylinder Low | Current | V | V | V | V | V | V | V |
| | Previous | V | V | V | V | V | V | V |
| Cylinder High | Current | V | V | V | V | V | V | V |
| | Previous | V | V | V | V | V | V | V |
| Device/Head | - | 1 | - | D | - | - | - | - |
| Command | 0 | 0 | 1 | 1 | 0 | 1 | 1 | 1 |

| Command Block Input Registers | | | | | | | | |
|-------------------------------|-----------------|---|---|---|---|---|---|---|
| Register | 7 | 6 | 5 | 4 | 3 | 2 | 1 | 0 |
| Data Low | - | - | - | - | - | - | - | - |
| Data High | - | - | - | - | - | - | - | - |
| Error | ...See Below... | | | | | | | |
| Sector Count | HOB=0 | - | - | - | - | - | - | - |
| | HOB=1 | - | - | - | - | - | - | - |
| Sector Number | HOB=0 | V | V | V | V | V | V | V |
| | HOB=1 | V | V | V | V | V | V | V |
| Cylinder Low | HOB=0 | V | V | V | V | V | V | V |
| | HOB=1 | V | V | V | V | V | V | V |
| Cylinder High | HOB=0 | V | V | V | V | V | V | V |
| | HOB=1 | V | V | V | V | V | V | V |
| Device/Head | - | - | - | - | - | - | - | - |
| Status | ...See Below... | | | | | | | |

| Error Register | | | | | | | |
|----------------|-----|---|-----|---|-----|-----|-----|
| 7 | 6 | 5 | 4 | 3 | 2 | 1 | 0 |
| CRC | UNC | 0 | IDN | 0 | ABT | TON | AMN |
| 0 | 0 | 0 | 0 | 0 | V | 0 | 0 |

| Status Register | | | | | | | |
|-----------------|-----|----|-----|-----|-----|-----|-----|
| 7 | 6 | 5 | 4 | 3 | 2 | 1 | 0 |
| BSY | RDY | DF | DSC | DRQ | COR | IDX | ERR |
| 0 | V | 0 | - | - | 0 | - | V |

Table 227 Set Max Address Ext Command (37h)

This command is immediately preceded by a Read Native Max Address Ext command.

This command overwrites the maximum number of Address of HDD in a range of actual device capacity. Once device receives this command, all accesses beyond that Address are rejected with setting ABORT bit in status register.

When the address requested is greater than 268,435,455, words (103:100) shall be modified to reflect the requested value, but words (61:60) shall not be modified. When the address requested is equal to or less than 268,435,455, words (103:100) shall be modified to reflect the requested value, and words (61:60) shall also be modified.

If this command is not supported, the maximum value to be set exceeds the capacity of the device, a host protected area has been established by a Set Max Address command, the command is not immediately preceded by a Read Native Max Address Ext command, or the device is in the Set Max Locked or Set Max Frozen state, the device shall return command aborted.

The device returns the command aborted for a second non-volatile Set Max Address Ext command until next power on or hardware reset.

Output Parameters To The Device

B Option bit for selection whether nonvolatile or volatile. B=0 is volatile condition. When B=1, MAX Address which is set by Set Max Address Ext command is preserved by POR. When B=0, MAX Address which is set by Set Max Address Ext command will be lost by POR. B=1 is not valid when the device is in Address Offset mode.

Sector Number Current Set Max LBA (7:0).

Sector Number Previous Set Max LBA (31:24).

Cylinder Low Current Set Max LBA (15:8).

| | |
|-------------------------------|----------------------|
| Cylinder Low Previous | Set Max LBA (39:32). |
| Cylinder High Current | Set Max LBA (23:16). |
| Cylinder High Previous | Set Max LBA (47:40). |

Input Parameters From The Device

| | |
|------------------------------|----------------------|
| Sector Number (HOB=0) | Set Max LBA (7:0). |
| Sector Number (HOB=1) | Set Max LBA (31:24). |
| Cylinder Low (HOB=0) | Set Max LBA (15:8). |
| Cylinder Low (HOB=1) | Set Max LBA (39:32). |
| Cylinder High (HOB=0) | Set Max LBA (23:16). |
| Cylinder High (HOB=1) | Set Max LBA (47:40). |

11.49 Set Multiple (C6h)

| Command Block Output Registers | | | | | | | | |
|--------------------------------|---|---|---|---|---|---|---|---|
| Register | 7 | 6 | 5 | 4 | 3 | 2 | 1 | 0 |
| Data | - | - | - | - | - | - | - | - |
| Feature | - | - | - | - | - | - | - | - |
| Sector Count | V | V | V | V | V | V | V | V |
| Sector Number | - | - | - | - | - | - | - | - |
| Cylinder Low | - | - | - | - | - | - | - | - |
| Cylinder High | - | - | - | - | - | - | - | - |
| Device/Head | 1 | - | 1 | D | - | - | - | - |
| Command | 1 | 1 | 0 | 0 | 0 | 1 | 1 | 0 |

| Command Block Input Registers | | | | | | | | |
|-------------------------------|-----------------|---|---|---|---|---|---|---|
| Register | 7 | 6 | 5 | 4 | 3 | 2 | 1 | 0 |
| Data | - | - | - | - | - | - | - | - |
| Error | ...See Below... | | | | | | | |
| Sector Count | - | - | - | - | - | - | - | - |
| Sector Number | - | - | - | - | - | - | - | - |
| Cylinder Low | - | - | - | - | - | - | - | - |
| Cylinder High | - | - | - | - | - | - | - | - |
| Device/Head | - | - | - | - | - | - | - | - |
| Status | ...See Below... | | | | | | | |

| Error Register | | | | | | | |
|----------------|-----|---|-----|---|-----|-----|-----|
| 7 | 6 | 5 | 4 | 3 | 2 | 1 | 0 |
| CRC | UNC | 0 | IDN | 0 | ABT | T0N | AMN |
| 0 | 0 | 0 | 0 | 0 | V | 0 | 0 |

| Status Register | | | | | | | |
|-----------------|-----|----|-----|-----|-----|-----|-----|
| 7 | 6 | 5 | 4 | 3 | 2 | 1 | 0 |
| BSY | RDY | DF | DSC | DRQ | COR | IDX | ERR |
| 0 | V | 0 | - | - | 0 | - | V |

Table 228 Set Multiple Commands (C6h)

The Set Multiple command enables the device to perform Read and Write Multiple commands and establishes the block size for these commands. The block size is the number of sectors to be transferred for each interrupt.

If an invalid block size is specified, an Abort error will be returned to the host, and Read Multiple and Write Multiple commands will be disabled.

Output Parameters To The Device

Sector Count. The block size to be used for Read Multiple and Write Multiple commands. Valid block sizes can be selected from 0, 1, 2, 4, 8 or 16. If 0 is specified, then Read Multiple and Write Multiple commands are disabled.

11.50 Set Sector Configuration Ext (B2h)

| Command Block Output Registers | | | | | | | | |
|--------------------------------|----------|---|---|---|---|---|---|---|
| Register | 7 | 6 | 5 | 4 | 3 | 2 | 1 | 0 |
| Data Low | - | - | - | - | - | - | - | - |
| Data High | - | - | - | - | - | - | - | - |
| Feature | Current | V | V | V | V | V | V | V |
| | Previous | V | V | V | V | V | V | V |
| Sector Count | Current | - | - | - | - | V | V | V |
| | Previous | - | - | - | - | - | - | V |
| Sector Number | Current | - | - | - | - | - | - | V |
| | Previous | - | - | - | - | - | - | - |
| Cylinder Low | Current | - | - | - | - | - | - | V |
| | Previous | - | - | - | - | - | - | V |
| Cylinder High | Current | - | - | - | - | - | - | - |
| | Previous | - | - | - | - | - | - | - |
| Device/Head | - | 1 | - | D | - | - | - | - |
| Command | 1 | 0 | 1 | 1 | 0 | 0 | 1 | 0 |

| Command Block Input Registers | | | | | | | | |
|-------------------------------|-----------------|---|---|---|---|---|---|---|
| Register | 7 | 6 | 5 | 4 | 3 | 2 | 1 | 0 |
| Data Low | - | - | - | - | - | - | - | - |
| Data High | - | - | - | - | - | - | - | - |
| Error | ...See Below... | | | | | | | |
| Sector Count | HOB=0 | - | - | - | - | - | - | - |
| | HOB=1 | - | - | - | - | - | - | - |
| Sector Number | HOB=0 | - | - | - | - | - | - | - |
| | HOB=1 | - | - | - | - | - | - | - |
| Cylinder Low | HOB=0 | - | - | - | - | - | - | - |
| | HOB=1 | - | - | - | - | - | - | - |
| Cylinder High | HOB=0 | - | - | - | - | - | - | - |
| | HOB=1 | - | - | - | - | - | - | - |
| Device/Head | - | - | - | - | - | - | - | - |
| Status | ...See Below... | | | | | | | |

| Error Register | | | | | | | |
|----------------|-----|---|-----|---|-----|-----|-----|
| 7 | 6 | 5 | 4 | 3 | 2 | 1 | 0 |
| CRC | UNC | 0 | IDN | 0 | ABT | TON | AMN |
| 0 | 0 | 0 | 0 | 0 | V | 0 | 0 |

| Status Register | | | | | | | |
|-----------------|-----|----|-----|-----|-----|-----|-----|
| 7 | 6 | 5 | 4 | 3 | 2 | 1 | 0 |
| BSY | RDY | DF | DSC | DRQ | COR | IDX | ERR |
| 0 | V | 0 | - | - | 0 | - | V |

Table 229 Set Sector Configuration Ext Commands (B2h)

The Set Sector Configuration Ext command sets the device logical block length and number of logical sectors per physical sector.

The successful processing of a Set Sector Configuration Ext command results in the device setting the following (See section **11.5 Section Set Sector Configuration Ext**):

- ACCESSIBLE CAPACITY field to the new native max address.
- Value of the LOGICAL TO PHYSICAL SECTOR RELATIONSHIP field
- Logical Sector Size

Note: No block sizes should be supported other than 512 bytes and 4096 bytes.

Note: Invalid customer formats are not supported, the command is aborted in this case.

Output Parameters To The Device

Feature The value in the Command Check field is taken from the Descriptor Check field (see 11.23.9) in the descriptor specified by the Sector Configuration Descriptor Index field.

The value in the Descriptor Check field shall not be equal to the value in the Descriptor Check field in any other valid Sector Configuration Descriptor in this device.

| Sector Count | bit | Description |
|--------------|------|---|
| | 15-3 | Reserved |
| | 2-0 | Sector Configuration Descriptor Index field |

11.51 Sleep (E6h/99h)

| Command Block Output Registers | | | | | | | | |
|--------------------------------|---|---|---|---|---|---|---|---|
| Register | 7 | 6 | 5 | 4 | 3 | 2 | 1 | 0 |
| Data | - | - | - | - | - | - | - | - |
| Feature | - | - | - | - | - | - | - | - |
| Sector Count | - | - | - | - | - | - | - | - |
| Sector Number | - | - | - | - | - | - | - | - |
| Cylinder Low | - | - | - | - | - | - | - | - |
| Cylinder High | - | - | - | - | - | - | - | - |
| Device/Head | 1 | - | 1 | D | - | - | - | - |
| Command | 1 | 1 | 1 | 0 | 0 | 1 | 1 | 0 |

| Command Block Input Registers | | | | | | | | |
|-------------------------------|-----------------|---|---|---|---|---|---|---|
| Register | 7 | 6 | 5 | 4 | 3 | 2 | 1 | 0 |
| Data | - | - | - | - | - | - | - | - |
| Error | ...See Below... | | | | | | | |
| Sector Count | - | - | - | - | - | - | - | - |
| Sector Number | - | - | - | - | - | - | - | - |
| Cylinder Low | - | - | - | - | - | - | - | - |
| Cylinder High | - | - | - | - | - | - | - | - |
| Device/Head | - | - | - | - | - | - | - | - |
| Status | ...See Below... | | | | | | | |

| Error Register | | | | | | | |
|----------------|-----|---|-----|---|-----|-----|-----|
| 7 | 6 | 5 | 4 | 3 | 2 | 1 | 0 |
| CRC | UNC | 0 | IDN | 0 | ABT | TON | AMN |
| 0 | 0 | 0 | 0 | 0 | V | 0 | 0 |

| Status Register | | | | | | | |
|-----------------|-----|----|-----|-----|-----|-----|-----|
| 7 | 6 | 5 | 4 | 3 | 2 | 1 | 0 |
| BSY | RDY | DF | DSC | DRQ | COR | IDX | ERR |
| 0 | V | 0 | V | - | 0 | - | V |

Table 230 Sleep Command (E6h/99h)

This command causes the device to enter Sleep Mode.

The device is spun down and the interface becomes inactive. If the device is already spun down, the spin down sequence is not executed.

The only way to recover from Sleep Mode is with software reset or hardware reset.

11.52 SMART Function Set (B0h)

| Command Block Output Registers | | | | | | | | |
|--------------------------------|---|---|---|---|---|---|---|---|
| Register | 7 | 6 | 5 | 4 | 3 | 2 | 1 | 0 |
| Data | - | - | - | - | - | - | - | - |
| Feature | V | V | V | V | V | V | V | V |
| Sector Count | V | V | V | V | V | V | V | V |
| Sector Number | V | V | V | V | V | V | V | V |
| Cylinder Low | 0 | 1 | 0 | 0 | 1 | 1 | 1 | 1 |
| Cylinder High | 1 | 1 | 0 | 0 | 0 | 0 | 1 | 0 |
| Device/Head | 1 | - | 1 | D | - | - | - | - |
| Command | 1 | 0 | 1 | 1 | 0 | 0 | 0 | 0 |

| Command Block Input Registers | | | | | | | | |
|-------------------------------|-----------------|---|---|---|---|---|---|---|
| Register | 7 | 6 | 5 | 4 | 3 | 2 | 1 | 0 |
| Data | - | - | - | - | - | - | - | - |
| Error | ...See Below... | | | | | | | |
| Sector Count | - | - | - | - | - | - | - | - |
| Sector Number | - | - | - | - | - | - | - | - |
| Cylinder Low | - | - | - | - | - | - | - | - |
| Cylinder High | - | - | - | - | - | - | - | - |
| Device/Head | - | - | - | - | - | - | - | - |
| Status | ...See Below... | | | | | | | |

| Error Register | | | | | | | |
|----------------|-----|---|-----|---|-----|-----|-----|
| 7 | 6 | 5 | 4 | 3 | 2 | 1 | 0 |
| CRC | UNC | 0 | IDN | 0 | ABT | TON | AMN |
| 0 | V | 0 | V | 0 | V | 0 | 0 |

| Status Register | | | | | | | |
|-----------------|-----|----|-----|-----|-----|-----|-----|
| 7 | 6 | 5 | 4 | 3 | 2 | 1 | 0 |
| BSY | RDY | DF | DSC | DRQ | COR | IDX | ERR |
| 0 | V | 0 | V | - | 0 | - | V |

Table 231 SMART Function Set Command (B0h)

The SMART Function Set command provides access to Attribute Values, Attribute Thresholds and other low level subcommands that can be used for logging and reporting purposes and to accommodate special user needs. The SMART Function Set command has several separate subcommands which are selectable via the device's Features Register when the SMART Function Set command is issued by the host.

11.52.1 SMART Subcommand

In order to select a subcommand the host must write the subcommand code to the device's Features Register before issuing the SMART Function Set command. The subcommands and their respective codes are listed below.

| Code | Subcommand |
|-------------|---|
| D0h | SMART Read Attribute Values |
| D1h | SMART Read Attribute Thresholds |
| D2h | SMART Enable/Disable Attribute Autosave |
| D3h | SMART Save Attribute Values |
| D4h | SMART Execute Off-line Immediate |
| D5h | SMART Read Log Sector |
| D6h | SMART Write Log Sector |
| D8h | SMART Enable Operations |
| D9h | SMART Disable Operations |
| DAh | SMART Return Status |
| DBh | SMART Enable/Disable Automatic Off-Line |

11.52.1.1 SMART Read Attribute Values (Subcommand D0h)

This subcommand returns the device's Attribute Values to the host. Upon receipt of the SMART Read Attribute Values subcommand from the host, the device saves any updated Attribute Values to the Attribute Data sectors, and then transfers the 512 bytes of Attribute Value information to the host.

11.52.1.2 SMART Read Attribute Thresholds (Subcommand D1h)

This subcommand returns the device's Attribute Thresholds to the host. Upon receipt of the SMART Read Attribute Thresholds subcommand from the host, the device reads the Attribute Thresholds from the Attribute Threshold sectors, and then transfers the 512 bytes of Attribute Thresholds information to the host.

11.52.1.3 SMART Enable/Disable Attribute Autosave (Subcommand D2h)

This subcommand Enables and Disables the Attribute Autosave feature of the device. The SMART Enable/Disable Attribute Autosave subcommand either allows the device to automatically save its updated Attribute Values to the Attribute Data Sector periodically; or this subcommand causes the Autosave feature to be disabled. The state of the Attribute Autosave feature (either enabled or disabled) will be preserved by the device across power cycle.

A value of 00h written by the host into the device's Sector Count Register before issuing the SMART Enable/Disable Attribute Autosave subcommand will cause this feature to be disabled. Disabling this feature does not preclude the device from saving Attribute Values to the Attribute Data sectors during some other normal operation such as during a power-up or power-down.

A value of F1h written by the host into the device's Sector Count Register before issuing the SMART Enable/Disable Attribute Autosave subcommand will cause this feature to be enabled. Any other non-zero value written by the host into this register before issuing the SMART Enable/Disable Attribute Autosave subcommand will not change the current Autosave status but the device will respond with the error code specified in Table 245.

The SMART Disable Operations subcommand disables the Autosave feature along with the device's SMART operations.

Upon the receipt of the subcommand from the host, the device asserts BSY, Enables or Disables the Autosave feature, clears BSY and asserts INTRQ.

11.52.1.4 SMART Save Attribute Values (Subcommand D3h)

This subcommand causes the device to immediately save any updated Attribute Values to the device's Attribute Data sector regardless of the state of the Attribute Autosave feature. Upon receipt of the SMART Save Attribute Values subcommand from the host, the device writes any updated Attribute Values to the Attribute Data sector.

11.52.1.5 SMART Execute Off-line Immediate (Subcommand D4h)

This subcommand causes the device to immediately initiate the set of activities that collect Attribute data in an off-line mode (off-line routine) or execute a self-test routine in either captive or off-line mode.

The Sector Number register shall be set to specify the operation to be executed.

| Sector Number | Operation to be executed |
|----------------------|--|
| 0 | Execute SMART off-line data collection routine immediately |
| 1 | Execute SMART Short self-test routine immediately in off-line mode |
| 2 | Execute SMART Extended self-test routine immediately in off-line mode |
| 4 | Execute SMART Selective self-test routine immediately in off-line mode |
| 127 | Abort off-line mode self-test routine |
| 129 | Execute SMART Short self-test routine immediately in captive mode |
| 130 | Execute SMART Extended self-test routine immediately in captive mode |
| 132 | Execute SMART Selective self-test routine immediately in captive mode |

Off-line mode: The device executes command completion before executing the specified routine. During execution of the routine the device will not set BSY nor clear DRDY. If the device is in the process of performing its routine and is interrupted by a new command from the host, the device will abort or suspend its routine and service the host within two seconds after receipt of the new command. After servicing the interrupting command, the device will resume its routine automatically or not start its routine depending on the interrupting command.

Captive mode: When executing self-test in captive mode, the device sets BSY to one and executes the specified self-test routine after receipt of the command. At the end of the routine, the device sets the execution result in the Self-test execution status byte (Table 233) and ATA registers as below and executes command completion.

| | |
|-----------------|---|
| Status | Set ERR to one when self-test has failed |
| Error | Set ABRT to one when self-test has failed |
| Cyl Low | Set to F4h when self-test has failed |
| Cyl High | Set to 2Ch when self-test has failed |

11.52.1.6 SMART Read Log Sector (Subcommand D5h)

This command returns the specified log sector contents to the host.

The 512 bytes data are returned at a command and the Sector Count value shall be set to one. The Sector Number shall be set to specify the log sector address.

| Log sector address | Content | Type |
|--------------------|--|------------|
| 00h | Log directory | Read Only |
| 01h | Summary SMART Error Log | Read Only |
| 03h | Extended Comprehensive SMART Error Log | See Note |
| 06h | SMART Self-test Log | Read Only |
| 07h | Extended Self-test Log | See Note |
| 09h | Selective self-test Log | Read/Write |
| 80h-9Fh | Host vendor specific | Read/Write |

Note: Log addresses 03h and 07h are used by the Read Log Ext and Write Log Ext commands. If these log addresses are used with the SMART Read Log Sector command, the device shall return command aborted.

Table 232 Log Sector Addresses

11.52.1.7 SMART Write Log Sector (Subcommand D6h)

This command writes 512 bytes data to the specified log sector.

The 512 bytes data are transferred at a command and the Sector Count value shall be set to one. The Sector Number shall be set to specify the log sector address (Table 232). If Read Only log sector is specified, the device returns ABRT error.

11.52.1.8 SMART Enable Operations (Subcommand D8h)

This subcommand enables access to all SMART capabilities within the device. Prior to receipt of a SMART Enable Operations subcommand, Attribute Values are neither monitored nor saved by the device. The state of SMART (either enabled or disabled) will be preserved by the device across power cycles. Once enabled, the receipt of subsequent SMART Enable Operations subcommands will not affect any of the Attribute Values.

Upon receipt of the SMART Enable Operations subcommand from the host, the device enables SMART capabilities and functions, and then saves any updated Attribute Values to the Attribute Data sector.

11.52.1.9 SMART Disable Operations (Subcommand D9h)

This subcommand disables all SMART capabilities within the device including the device's attribute autosave feature. After receipt of this subcommand the device disables all SMART operations. Non self-preserved Attribute Values will no longer be monitored. The state of SMART (either enabled or disabled) is preserved by the device across power cycles.

Upon receipt of the SMART Disable Operations subcommand from the host, the device disables SMART capabilities and functions, and then saves any updated Attribute Values to the Attribute Data sector.

After receipt of the device of the SMART Disable Operations subcommand from the host, all other SMART subcommands – with the exception of SMART Enable Operations – are disabled, and invalid and will be aborted by the device (including the SMART Disable Operations subcommand), returning the error code as specified in Table 245 on the page 295.

Any Attribute Values accumulated and saved to volatile memory prior to receipt of the SMART Disable Operations command will be preserved in the device's Attribute Data Sectors. If the device is re-enabled, these Attribute Values will be updated, as needed, upon receipt of a SMART Read Attribute Values or SMART Save Attribute Values command.

11.52.1.10 SMART Return Status (Subcommand DAh)

This command is used to communicate the reliability status of the device to the host's request. Upon receipt of the SMART Return Status subcommand the device saves any updated Pre-failure type Attribute Values to the reserved sector and compares the updated Attribute Values to the Attribute Thresholds.

If the device does not detect a Threshold Exceeded Condition, the device loads 4Fh into the Cylinder Low register, C2h into the Cylinder High register.

If the device detects a Threshold Exceeded Condition, the device loads F4h into the Cylinder Low register, 2Ch into the Cylinder High register.

11.52.1.11 SMART Enable/Disable Automatic Off-Line (Subcommand DBh)

This subcommand enables and disables the optional feature that causes the device to perform the set of off-line data collection activities that automatically collect attribute data in an off-line mode and then save this data to the device's non-volatile memory. This subcommand may either cause the device to automatically initiate or resume performance of its off-line data collection activities or cause the automatic off-line data collection feature to be disabled.

A value of zero written by the host into the device's Sector Count Register before issuing this subcommand shall cause the feature to be disabled. Disabling this feature does not preclude the device from saving attribute values to non-volatile memory during some other normal operation such as during a power-on or power-off sequence or during an error recovery sequence.

A value of F8h written by the host into the device's Sector Count Register before issuing this subcommand shall cause this feature to be enabled. Any other non-zero value written by the host into this register before issuing this subcommand is vendor specific and will not change the current Automatic Off-Line Data Collection, but the device may respond with the error code specified in Table 245 on the page.295

11.52.2 Device Attributes Data Structure

The following defines the 512 bytes that make up the Attribute Value information. This data structure is accessed by the host in its entirety using the SMART Read Attribute Values subcommand. All multi-byte fields shown in these data structures are in byte ordering, namely that the least significant byte occupies the lowest numbered byte address location in the field.

| Description | Bytes | Offset | Value |
|--|-------|--------|-------|
| Data Structure Revision Number | 2 | 00h | 0010h |
| 1 st Device Attribute | 12 | 02h | |
| ... | .. | | |
| ... | .. | | |
| 30 th Device Attribute | 12 | 15Eh | |
| Off-line data collection status | 1 | 16Ah | |
| Self-test execution status | 1 | 16Bh | |
| Total time in seconds to complete off-line data collection activity | 2 | 16Ch | |
| Vender specific | 1 | 16Eh | |
| Off-line data collection capability | 1 | 16Fh | 1Bh |
| SMART capability | 2 | 170h | 0003h |
| SMART device error logging capability | 1 | 172h | 01h |
| Self-test failure check point | 1 | 173h | |
| Short self-test completion time in minutes | 1 | 174h | |
| Extended self-test completion time in minutes. If 0FFh, use bytes 177h and 178h for completion time. | 1 | 175h | |
| Reserved | 1 | 176h | |
| Extended self-test completion time in minutes. (word) | 2 | 177h | |
| Reserved | 9 | 179h | |
| Vendor specific | 125 | 182h | |
| Data structure checksum | 1 | 1FFh | |
| | 512 | | |

Table 233 Device Attribute Data Structure

11.52.2.1 Data Structure Revision Number

The Data Structure Revision Number identifies which version of this data structure is implemented by the device. This revision number identifies both the Attribute Value and Attribute Threshold Data structures.

11.52.2.2 Individual Attribute Data Structure

The following defines the 12 bytes that make up the information for each Attribute entry in the Device Attribute Data Structure.

| Description | Bytes | Offset |
|--|-------|--------|
| Attribute ID Number (01h to FFh) | 1 | 00h |
| Status Flags | 2 | 01h |
| Attribute Value (valid values from 01h to FDh) | 1 | 03h |
| Vender specific | 8 | 04h |
| Total Bytes | 12 | |

Table 234 Individual Attribute Data Structure

Attribute ID Numbers: Any non-zero value in the Attribute ID Number indicates an active attribute. The device supports following Attribute ID Numbers.

| ID | Attribute Name |
|-----|---|
| 0 | Indicates that this entry in the data structure is not used |
| 1 | Raw Read Error Rate |
| 2 | Throughput Performance |
| 3 | Spin Up Time |
| 4 | Start/Stop Count |
| 5 | Reallocated Sector Count |
| 7 | Seek Error Rate |
| 8 | Seek Time Performance |
| 9 | Power-On Hours Count |
| 10 | Spin Retry Count |
| 12 | Device Power Cycle Count |
| 22 | Internal Environment status |
| 192 | Power off Retract count |
| 193 | Load Cycle count |
| 194 | Temperature |
| 196 | Reallocation Event Count |
| 197 | Current Pending Sector Count |
| 198 | Off-Line Scan Uncorrectable Sector Count |
| 199 | Ultra DMA CRC Error Count |

Status Flag Definitions

| Bit | Definition |
|------|---|
| 0 | Pre-failure/advisory bit |
| 0 | An Attribute Value less than or equal to its corresponding Attribute Threshold indicates an advisory condition where the usage or age of the device has exceeded its intended design life period. |
| 1 | An Attribute Value less than or equal to its corresponding attribute threshold indicates a pre-Failure condition where imminent loss of data is being predicted. |
| 1 | On-Line Collective bit |
| 0 | The Attribute Value is updated only during Off-Line testing |
| 1 | The Attribute Value is updated during On-Line testing or during both On-Line and Off-Line testing. |
| 2-5 | Vendor specific |
| 6-15 | Reserved (0) |

Normalized Values: The device will perform conversion of the raw Attribute Values to transform them into normalized values, which the host can then compare with the Threshold values. A Threshold is the excursion limit for a normalized Attribute Value.

11.52.2.3 Off-Line Data Collection Status

The value of this byte defines the current status of the off-line activities of the device. Bit 7 indicates Automatic Off-Line Data Collection Status.

Bit 7 Automatic Off-Line Data Collection Status

- 0** Automatic Off-Line Data Collection is disabled.
- 1** Automatic Off-Line Data Collection is enabled.

Bits 0 thru 6 represent a hexadecimal status value reported by the device.

Value Definition

- 0** Off-line data collection never started
- 2** All segments completed without errors.
- 4** Off-line data collection suspended by interrupting command
- 5** Off-line data collecting aborted by interrupting command
- 6** Off-line data collection aborted with fatal error

11.52.2.4 Self-Test Execution Status

Bit Definition

- 0-3** Percent Self-test remaining

An approximation of the percent of the self-test routine remaining until completion in ten percent increments. Valid values are 0 through 9.

- 4-7** Current Self-test execution status

- 0** The self-test routine completed without error or has never been run
- 1** The self-test routine aborted by the host
- 2** The self-test routine interrupted by the host with a hard or soft reset
- 3** The device was unable to complete the self-test routine due to a fatal error or unknown test error
- 4** The self-test routine completed with unknown element failure
- 5** The self-test routine completed with electrical element failure
- 6** The self-test routine completed with servo element failure
- 7** The self-test routine completed with read element failure
- 15** The self-test routine in progress

11.52.2.5 Total Time in Seconds to Complete Off-line Data Collection Activity

This field tells the host how many seconds the device requires completing the off-line data collection activity.

11.52.2.6 Off-Line Data Collection Capability

| Bit | Definition |
|-----|--|
| 0 | Execute Off-line Immediate implemented bit |
| 0 | SMART Execute Off-line Immediate subcommand is not implemented |
| 1 | SMART Execute Off-line Immediate subcommand is implemented |
| 1 | Enable/disable Automatic Off-line implemented bit |
| 0 | SMART Enable/disable Automatic Off-line subcommand is not implemented |
| 1 | SMART Enable/disable Automatic Off-line subcommand is implemented |
| 2 | abort/restart off-line by host bit |
| 0 | The device will suspend off-line data collection activity after an interrupting command and resume it after some vendor specific event |
| 1 | The device will abort off-line data collection activity upon receipt of a new command |
| 3 | Off-line Read Scanning implemented bit |
| 0 | The device does not support Off-line Read Scanning |
| 1 | The device supports Off-line Read Scanning |
| 4 | Self-test implemented bit |
| 0 | Self-test routine is not implemented |
| 1 | Self-test routine is implemented |
| 5-7 | Reserved (0) |
| 6 | Selective self-test implemented bit |
| 0 | Selective self-test routine is not implemented |
| 1 | Selective self-test routine is implemented |

11.52.2.7 SMART Capability

This word of bit flags describes the SMART capabilities of the device. The device will return 03h indicating that the device will save its Attribute Values prior to going into a power saving mode and supports the SMART ENABLE/DISABLE ATTRIBUTE AUTOSAVE command.

| Bit | Definition |
|------|--|
| 0 | Pre-power mode attribute saving capability If bit = 1, the device will save its Attribute Values prior to going into a power saving mode (Standby or Sleep mode). |
| 1 | Attribute autosave capability If bit = 1, the device supports the SMART ENABLE/DISABLE ATTRIBUTE AUTOSAVE command. |
| 2-15 | Reserved (0) |

11.52.2.8 Error Logging Capability

| Bit | Definition |
|-----|--|
| 7-1 | Reserved (0) |
| 0 | Error Logging support bit If bit = 1, the device supports the Error Logging |

11.52.2.9 Self-Test Failure Check Point

This byte indicates the section of self-test where the device detected a failure.

11.52.2.10 Self-Test Completion Time

These bytes are the minimum time in minutes to complete self-test.

11.52.2.11 Data Structure Checksum

The Data Structure Checksum is the 2's compliment of the result of a simple 8-bit addition of the first 511 bytes in the data structure.

11.52.3 Device Attribute Thresholds Data Structure

The following defines the 512 bytes that make up the Attribute Threshold information. This data structure is accessed by the host in its entirety using the SMART Read Attribute Thresholds. All multi-byte fields shown in these data structures follow the ATA/ATAPI-7 specification for byte ordering, namely that the least significant byte occupies the lowest numbered byte address location in the field.

The sequence of active Attribute Thresholds will appear in the same order as their corresponding Attribute Values.

| Description | Bytes | Offset | Value |
|--------------------------------------|-------|--------|-------|
| Data Structure Revision Number | 2 | 00h | 0010h |
| 1 st Attribute Threshold | 12 | 02h | |
| ... | .. | | |
| ... | .. | | |
| 30 th Attribute Threshold | 12 | 15Eh | |
| Reserved | 18 | 16Ah | 00h |
| Vendor specific | 131 | 17Ch | 00h |
| Data structure checksum | 1 | 1FFh | |
| | 512 | | |

Table 235 Device Attribute Thresholds Data Structure

11.52.3.1 Data Structure Revision Number

This value is the same as the value used in the Device Attributes Values Data Structure.

11.52.3.2 Individual Thresholds Data Structure

The following defines the 12 bytes that make up the information for each Threshold entry in the Device Attribute Thresholds Data Structure. Attribute entries in the Individual Threshold Data Structure are in the same order and correspond to the entries in the Individual Attribute Data Structure.

| Description | Bytes | Offset |
|----------------------------------|-------|--------|
| Attribute ID Number (01h to FFh) | 1 | 00h |
| Attribute Threshold | 1 | 01h |
| Reserved (00h) | 10 | 02h |
| Total Bytes | 12 | |

Table 236 Individual Threshold Data Structure

11.52.3.3 Attribute ID Numbers

Attribute ID Numbers supported by the device are the same as Attribute Values Data Structures.

11.52.3.4 Attribute Threshold

These values are preset at the factory and are not meant to be changeable.

11.52.3.5 Data Structure Checksum

The Data Structure Checksum is the 2's compliment of the result of a simple 8-bit addition of the first 511 bytes in the data structure.

11.52.4 SMART Log Directory

Table 237 defines the 512 bytes that make up the SMART Log Directory. The SMART Log Directory is SMART Log Address zero and is defined as one sector long.

| Description | Bytes | Offset |
|---|-------|--------|
| SMART Logging Version | 2 | 00h |
| Number of sectors in the log at log address 1 | 1 | 02h |
| Reserved | 1 | 03h |
| Number of sectors in the log at log address 2 | 1 | 04h |
| Reserved | 1 | 05h |
| ... | ... | ... |
| Number of sectors in the log at log address 255 | 1 | 1Feh |
| Reserved | 1 | 1FFh |
| | 512 | |

Table 237 SMART Log Directory

The value of the SMART Logging Version word shall be 01h. The logs at log addresses 80-9Fh shall each be defined as 16 sectors long.

11.52.5 SMART Summary Error Log Sector

The following defines the 512 bytes that make up the SMART summary error log sector. All multi-byte fields shown in this data structure follow the ATA/ATAPI-7 specifications for byte ordering.

| Description | Bytes | Offset |
|--|-------|--------|
| SMART error log version | 1 | 00h |
| Error log index | 1 | 01h |
| 1 st error log data structure | 90 | 02h |
| 2 nd error log data structure | 90 | 5Ch |
| 3 rd error log data structure | 90 | B6h |
| 4 th error log data structure | 90 | 110h |
| 5 th error log data structure | 90 | 16Ah |
| Device error count | 2 | 1C4h |
| Reserved | 57 | 1C6h |
| Data structure checksum | 1 | 1FFh |
| | 512 | |

Table 238 SMART Summary Error Log Sector

11.52.5.1 SMART Error Log Version

This value is set to 01h.

11.52.5.2 Error Log Index

This points the most recent error log data structure. Only values 1 through 5 are valid.

11.52.5.3 Device Error Count

This field contains the total number of errors. The value will not roll over.

11.52.5.4 Error Log Data Structure

Data format of each error log structure is shown below.

| Description | Bytes | Offset |
|--|-------|--------|
| 1 st error log data structure | 12 | 00h |
| 2 nd error log data structure | 12 | 0Ch |
| 3 rd error log data structure | 12 | 18h |
| 4 th error log data structure | 12 | 24h |
| 5 th error log data structure | 12 | 30h |
| Error data structure | 30 | 3Ch |
| | 90 | |

Table 239 Error Log Data Structure

Command data structure: Data format of each command data structure is shown below.

| Description | Bytes | Offset |
|--|-------|--------|
| Device Control register | 1 | 00h |
| Features register | 1 | 01h |
| Sector count register | 1 | 02h |
| Sector number register | 1 | 03h |
| Cylinder Low register | 1 | 04h |
| Cylinder High register | 1 | 05h |
| Device/Head register | 1 | 06h |
| Command register | 1 | 07h |
| Timestamp (milliseconds from Power On) | 4 | 08h |
| | 12 | |

Table 240 Command Data Structure

Error data structure: Data format of error data structure is shown below.

| Description | Bytes | Offset |
|---------------------------------------|-------|--------|
| Reserved | 1 | 00h |
| Error register | 1 | 01h |
| Sector count register | 1 | 02h |
| Sector number register | 1 | 03h |
| Cylinder Low register | 1 | 04h |
| Cylinder High register | 1 | 05h |
| Device/Head register | 1 | 06h |
| Status register | 1 | 07h |
| Extended error data (vendor specific) | 19 | 08h |
| State | 1 | 1Bh |
| Life timestamp (hours) | 2 | 1Ch |
| | 30 | |

Table 241 Error Data Structure

State field contains a value indicating the device state when command was issued to the device.

| Value | State |
|---------|---|
| x0h | Unknown |
| x1h | Sleep |
| x2h | Standby (If the EPC feature set is enabled, Standby is standby_y or standby_z) |
| x3h | Active/Idle (If the EPC feature set is enabled, Active/Idle is idle_a or idle_b or idle_c) |
| x4h | SMART Off-line or Self-test |
| x5h-xAh | Reserved |
| xBh-xFh | Vendor specific |

Note: The value of x is vendor specific.

11.52.6 Self-Test Log Data Structure

The following defines the 512 bytes that make up the Self-test log sector. All multi-byte fields shown in these data structures follow the ATA/ATAPI-7 specifications for byte ordering.

| Description | Bytes | Offset |
|-------------------------------|-------|-----------|
| Data structure revision | 2 | 00h |
| Self-test number | 1 | n*18h+02h |
| Self-test execution status | 1 | n*18h+03h |
| Life time power on hours | 2 | n*18h+04h |
| Self-test failure check point | 1 | n*18h+06h |
| LBA of first failure | 4 | n*18h+07h |
| Vendor specific | 15 | n*18h+0Bh |
| ... | | |
| Vendor specific | 2 | 1Fah |
| Self-test index | 1 | 1FCh |
| Reserved | 2 | 1FDh |
| Data structure checksum | 1 | 1FFh |
| | 512 | |

Note: n is 0 through 20

Table 242 Self-Test Log Data Structure

The data structure contains the descriptor of Self-test that the device has performed. Each descriptor is 24 bytes long and the self-test data structure is capable to contain up to 21 descriptors.

After 21 descriptors have been recorded, the oldest descriptor will be overwritten with new descriptor.

Self-test index points the most recent descriptor. When there is no descriptor the value is 0. When there is descriptor(s) the value is 1 through 21.

11.52.7 Selective Self-Test Log Data Structure

The Selective Self-Test Log is a log that may be both written and read by the host. This log allows the host to select the parameters for the self-test and to monitor the progress of the self-test. The following table defines the contents of the Selective self-test log which is 512 bytes long. All multi-byte fields shown in these data structures follow the ATA/ATAPI-7 specifications for byte ordering.

| Description | Bytes | Offset | Read/Write |
|----------------------------------|-------|--------|-----------------|
| Data structure revision | 2 | 00h | R/W |
| Starting LBA for test span 1 | 8 | 02h | R/W |
| Ending LBA for test span 1 | 8 | 0Ah | R/W |
| Starting LBA for test span 2 | 8 | 12h | R/W |
| Ending LBA for test span 2 | 8 | 1Ah | R/W |
| Starting LBA for test span 3 | 8 | 22h | R/W |
| Ending LBA for test span 3 | 8 | 2Ah | R/W |
| Starting LBA for test span 4 | 8 | 32h | R/W |
| Ending LBA for test span 4 | 8 | 3Ah | R/W |
| Starting LBA for test span 5 | 8 | 42h | R/W |
| Ending LBA for test span 5 | 8 | 4Ah | R/W |
| Reserved | 256 | 52h | Reserved |
| Vendor specific | 154 | 152h | Vendor specific |
| Current LBA under test | 8 | 1Ech | Read |
| Current span under test | 2 | 1F4h | Read |
| Feature flags | 2 | 1F6h | R/W |
| Vendor specific | 4 | 1F8h | Vendor specific |
| Selective self-test pending time | 2 | 1FCh | R/W |
| Reserved | 1 | 1Feh | Reserved |
| Data structure checksum | 1 | 1FFh | R/W |
| | 512 | | |

Table 243 Selective Self-Test Log Data Structure

11.52.7.1 Feature Flags

The Feature flags define the features of Selective Self-Test to be executed.

| Bit | Description |
|------|---|
| 0 | Vendor specific |
| 1 | When set to one, perform off-line scan after selective test. |
| 2 | Vendor specific |
| 3 | When set to one, off-line scan after selective test is pending. |
| 4 | When set to one, off-line scan after selective test is active. |
| 5-15 | Reserved. |

Table 244 Selective Self-Test Feature Flags

11.52.8 Error Reporting

The following table shows the values returned in the Status and Error Registers when specific error conditions are encountered by a device.

| Error Condition | Status Register | Error Register |
|--|-----------------|----------------|
| A SMART FUNCTION SET command was received by the device without the required key being loaded into the Cylinder High and Cylinder Low registers. | 51h | 04h |
| A SMART FUNCTION SET command was received by the device with a subcommand value in the Features Register that is either invalid or not supported by this device. | 51h | 04h |
| A SMART FUNCTION SET command subcommand other than SMART ENABLE OPERATIONS was received by the device while the device was in a "SMART disabled" state. | 51h | 04h |
| The device is unable to read its Attribute Values or Attribute Thresholds data structure. | 51h | 10h or 40h |
| The device is unable to write to its Attribute Values data structure. | 51h | 10h |

Table 245 SMART Error Codes

11.53 Standby (E2h/96h)

| Command Block Output Registers | | | | | | | | |
|--------------------------------|---|---|---|---|---|---|---|---|
| Register | 7 | 6 | 5 | 4 | 3 | 2 | 1 | 0 |
| Data | - | - | - | - | - | - | - | - |
| Feature | - | - | - | - | - | - | - | - |
| Sector Count | V | V | V | V | V | V | V | V |
| Sector Number | - | - | - | - | - | - | - | - |
| Cylinder Low | - | - | - | - | - | - | - | - |
| Cylinder High | - | - | - | - | - | - | - | - |
| Device/Head | 1 | - | 1 | D | - | - | - | - |
| Command | 1 | 1 | 1 | 0 | 0 | 0 | 1 | 0 |

| Command Block Input Registers | | | | | | | | |
|-------------------------------|-----------------|---|---|---|---|---|---|---|
| Register | 7 | 6 | 5 | 4 | 3 | 2 | 1 | 0 |
| Data | - | - | - | - | - | - | - | - |
| Error | ...See Below... | | | | | | | |
| Sector Count | - | - | - | - | - | - | - | - |
| Sector Number | - | - | - | - | - | - | - | - |
| Cylinder Low | - | - | - | - | - | - | - | - |
| Cylinder High | - | - | - | - | - | - | - | - |
| Device/Head | - | - | - | - | - | - | - | - |
| Status | ...See Below... | | | | | | | |

| Error Register | | | | | | | |
|----------------|-----|---|-----|---|-----|-----|-----|
| 7 | 6 | 5 | 4 | 3 | 2 | 1 | 0 |
| CRC | UNC | 0 | IDN | 0 | ABT | T0N | AMN |
| 0 | 0 | 0 | 0 | 0 | V | 0 | 0 |

| Status Register | | | | | | | |
|-----------------|-----|----|-----|-----|-----|-----|-----|
| 7 | 6 | 5 | 4 | 3 | 2 | 1 | 0 |
| BSY | RDY | DF | DSC | DRQ | COR | IDX | ERR |
| 0 | V | 0 | V | - | 0 | - | V |

Table 246 Standby Command (E2h/96h)

The Standby command causes the device to enter the Standby Mode immediately, and set auto power down timeout parameter (standby timer).

When the Standby mode is entered, the drive is spun down but the interface remains active. If the drive is already spun down, the spin down sequence is not executed.

During the Standby mode the device will respond to commands, but there is a delay while waiting for the spindle to reach operating speed.

The automatic power down sequence is enabled and the timer starts counting down when the drive returns to Idle mode.

If the EPC feature set is enabled, device enters into the Standby_Z power condition.

Output Parameters To The Device

Sector Count Timeout Parameter. If zero, the timeout interval (Standby Timer) is NOT disabled. If non-zero, then the automatic power down sequence is enabled, and the timeout interval is shown below:

| Value | Description |
|---------|--------------------------|
| 0 | Timer disabled |
| 1-240 | Value * 5 seconds |
| 241-251 | (Value-240) * 30 minutes |
| 252 | 21 minutes |
| 253 | 8 hours |
| 254 | Aborted |
| 255 | 21 minutes 15 seconds |

When the automatic power down sequence is enabled, the drive will enter Standby mode automatically if the timeout interval expires with no drive access from the host. The timeout interval will be reinitialized if there is a drive access before the timeout interval expires.

11.54 Standby Immediate (E0h/94h)

| Command Block Output Registers | | | | | | | | |
|--------------------------------|---|---|---|---|---|---|---|---|
| Register | 7 | 6 | 5 | 4 | 3 | 2 | 1 | 0 |
| Data | - | - | - | - | - | - | - | - |
| Feature | - | - | - | - | - | - | - | - |
| Sector Count | - | - | - | - | - | - | - | - |
| Sector Number | - | - | - | - | - | - | - | - |
| Cylinder Low | - | - | - | - | - | - | - | - |
| Cylinder High | - | - | - | - | - | - | - | - |
| Device/Head | 1 | - | 1 | D | - | - | - | - |
| Command | 1 | 1 | 1 | 0 | 0 | 0 | 0 | 0 |

| Command Block Input Registers | | | | | | | | |
|-------------------------------|-----------------|---|---|---|---|---|---|---|
| Register | 7 | 6 | 5 | 4 | 3 | 2 | 1 | 0 |
| Data | - | - | - | - | - | - | - | - |
| Error | ...See Below... | | | | | | | |
| Sector Count | - | - | - | - | - | - | - | - |
| Sector Number | - | - | - | - | - | - | - | - |
| Cylinder Low | - | - | - | - | - | - | - | - |
| Cylinder High | - | - | - | - | - | - | - | - |
| Device/Head | - | - | - | - | - | - | - | - |
| Status | ...See Below... | | | | | | | |

| Error Register | | | | | | | |
|----------------|-----|---|-----|---|-----|-----|-----|
| 7 | 6 | 5 | 4 | 3 | 2 | 1 | 0 |
| CRC | UNC | 0 | IDN | 0 | ABT | T0N | AMN |
| 0 | 0 | 0 | 0 | 0 | V | 0 | 0 |

| Status Register | | | | | | | |
|-----------------|-----|----|-----|-----|-----|-----|-----|
| 7 | 6 | 5 | 4 | 3 | 2 | 1 | 0 |
| BSY | RDY | DF | DSC | DRQ | COR | IDX | ERR |
| 0 | V | 0 | V | - | 0 | - | V |

Table 247 Standby Immediate Command (E0h/94h)

The Standby Immediate command causes the device to enter Standby mode immediately.

The device is spun down but the interface remains active. If the device is already spun down, the spin down sequence is not executed.

During the Standby mode, the device will respond to commands, but there is a delay while waiting for the spindle to reach operating speed.

The Standby Immediate command will not affect the auto power down timeout parameter.

If the EPC feature set is enabled, device enters into the Standby_Z power condition.

11.55 Trusted Receive (5Ch)

| Command Block Output Registers | | | | | | | | |
|--------------------------------|---|---|---|---|---|---|---|---|
| Register | 7 | 6 | 5 | 4 | 3 | 2 | 1 | 0 |
| Data | - | - | - | - | - | - | - | - |
| Feature | V | V | V | V | V | V | V | V |
| Sector Count | V | V | V | V | V | V | V | V |
| Sector Number | V | V | V | V | V | V | V | V |
| Cylinder Low | V | V | V | V | V | V | V | V |
| Cylinder High | V | V | V | V | V | V | V | V |
| Device/Head | - | - | - | - | - | - | - | - |
| Command | 0 | 1 | 0 | 1 | 1 | 1 | 0 | 0 |

| Command Block Input Registers | | | | | | | | |
|-------------------------------|-----------------|---|---|---|---|---|---|---|
| Register | 7 | 6 | 5 | 4 | 3 | 2 | 1 | 0 |
| Data | - | - | - | - | - | - | - | - |
| Error | ...See Below... | | | | | | | |
| Sector Count | - | - | - | - | - | - | - | - |
| Sector Number | - | - | - | - | - | - | - | - |
| Cylinder Low | - | - | - | - | - | - | - | - |
| Cylinder High | - | - | - | - | - | - | - | - |
| Device/Head | - | - | - | - | - | - | - | - |
| Status | ...See Below... | | | | | | | |

| Error Register | | | | | | | |
|----------------|-----|---|-----|---|-----|-----|-----|
| 7 | 6 | 5 | 4 | 3 | 2 | 1 | 0 |
| CRC | UNC | 0 | IDN | 0 | ABT | T0N | AMN |
| 0 | 0 | 0 | 0 | 0 | V | 0 | 0 |

| Status Register | | | | | | | |
|-----------------|-----|----|-----|-----|-----|-----|-----|
| 7 | 6 | 5 | 4 | 3 | 2 | 1 | 0 |
| BSY | RDY | DF | DSC | DRQ | COR | IDX | ERR |
| 0 | V | 0 | - | - | 0 | 0 | V |

Table 248 Trusted Receive Command (5Ch)

The Trusted Receive command reads one or more 512 byte packets from the drive. The returned packets depend on the Security Protocol selected (feature). See Trusted Command Feature for details.

The sectors are transferred through the Data Register 16 bits at a time.

11.56 Trusted Receive DMA (5Dh)

| Command Block Output Registers | | | | | | | | |
|--------------------------------|---|---|---|---|---|---|---|---|
| Register | 7 | 6 | 5 | 4 | 3 | 2 | 1 | 0 |
| Data | - | - | - | - | - | - | - | - |
| Feature | V | V | V | V | V | V | V | V |
| Sector Count | V | V | V | V | V | V | V | V |
| Sector Number | V | V | V | V | V | V | V | V |
| Cylinder Low | V | V | V | V | V | V | V | V |
| Cylinder High | V | V | V | V | V | V | V | V |
| Device/Head | - | - | - | - | - | - | - | - |
| Command | 0 | 1 | 0 | 1 | 1 | 1 | 0 | 1 |

| Command Block Input Registers | | | | | | | | |
|-------------------------------|-----------------|---|---|---|---|---|---|---|
| Register | 7 | 6 | 5 | 4 | 3 | 2 | 1 | 0 |
| Data | - | - | - | - | - | - | - | - |
| Error | ...See Below... | | | | | | | |
| Sector Count | - | - | - | - | - | - | - | - |
| Sector Number | - | - | - | - | - | - | - | - |
| Cylinder Low | - | - | - | - | - | - | - | - |
| Cylinder High | - | - | - | - | - | - | - | - |
| Device/Head | - | - | - | - | - | - | - | - |
| Status | ...See Below... | | | | | | | |

| Error Register | | | | | | | |
|----------------|-----|---|-----|---|-----|-----|-----|
| 7 | 6 | 5 | 4 | 3 | 2 | 1 | 0 |
| CRC | UNC | 0 | IDN | 0 | ABT | T0N | AMN |
| 0 | 0 | 0 | 0 | 0 | V | 0 | 0 |

| Status Register | | | | | | | |
|-----------------|-----|----|-----|-----|-----|-----|-----|
| 7 | 6 | 5 | 4 | 3 | 2 | 1 | 0 |
| BSY | RDY | DF | DSC | DRQ | COR | IDX | ERR |
| 0 | V | 0 | - | - | 0 | 0 | V |

Table 249 Trusted Receive DMA Command (5Dh)

The Trusted Receive DMA command reads one or more 512 byte packets from the drive. The returned packets depend on the Security Protocol selected (feature). See Trusted Command Feature for details.

The host initializes a slave-DMA channel prior to issuing the command. The data transfers are qualified by DMARQ and are performed by the slave-DMA channel. The device issues only one interrupt per command to indicate that data transfer has terminated and status is available.

11.57 Trusted Send (5Eh)

| Command Block Output Registers | | | | | | | | |
|--------------------------------|---|---|---|---|---|---|---|---|
| Register | 7 | 6 | 5 | 4 | 3 | 2 | 1 | 0 |
| Data | - | - | - | - | - | - | - | - |
| Feature | V | V | V | V | V | V | V | V |
| Sector Count | V | V | V | V | V | V | V | V |
| Sector Number | V | V | V | V | V | V | V | V |
| Cylinder Low | V | V | V | V | V | V | V | V |
| Cylinder High | V | V | V | V | V | V | V | V |
| Device/Head | - | - | - | - | - | - | - | - |
| Command | 0 | 1 | 0 | 1 | 1 | 1 | 1 | 0 |

| Command Block Input Registers | | | | | | | | |
|-------------------------------|-----------------|---|---|---|---|---|---|---|
| Register | 7 | 6 | 5 | 4 | 3 | 2 | 1 | 0 |
| Data | - | - | - | - | - | - | - | - |
| Error | ...See Below... | | | | | | | |
| Sector Count | - | - | - | - | - | - | - | - |
| Sector Number | - | - | - | - | - | - | - | - |
| Cylinder Low | - | - | - | - | - | - | - | - |
| Cylinder High | - | - | - | - | - | - | - | - |
| Device/Head | - | - | - | - | - | - | - | - |
| Status | ...See Below... | | | | | | | |

| Error Register | | | | | | | |
|----------------|-----|---|-----|---|-----|-----|-----|
| 7 | 6 | 5 | 4 | 3 | 2 | 1 | 0 |
| CRC | UNC | 0 | IDN | 0 | ABT | T0N | AMN |
| 0 | 0 | 0 | 0 | 0 | V | 0 | 0 |

| Status Register | | | | | | | |
|-----------------|-----|----|-----|-----|-----|-----|-----|
| 7 | 6 | 5 | 4 | 3 | 2 | 1 | 0 |
| BSY | RDY | DF | DSC | DRQ | COR | IDX | ERR |
| 0 | V | 0 | - | - | 0 | 0 | V |

Table 250 Trusted Send Command (5Eh)

The Trusted Send command writes one or more 512 byte packets to the drive. The content of the packets depend on the Security Protocol selected (feature). See Trusted Command Feature for details.

The sectors are transferred through the Data Register 16 bits at a time.

11.58 Trusted Send DMA (5Fh)

| Command Block Output Registers | | | | | | | | |
|--------------------------------|---|---|---|---|---|---|---|---|
| Register | 7 | 6 | 5 | 4 | 3 | 2 | 1 | 0 |
| Data | - | - | - | - | - | - | - | - |
| Feature | V | V | V | V | V | V | V | V |
| Sector Count | V | V | V | V | V | V | V | V |
| Sector Number | V | V | V | V | V | V | V | V |
| Cylinder Low | V | V | V | V | V | V | V | V |
| Cylinder High | V | V | V | V | V | V | V | V |
| Device/Head | - | - | - | - | - | - | - | - |
| Command | 0 | 1 | 0 | 1 | 1 | 1 | 1 | 1 |

| Command Block Input Registers | | | | | | | | |
|-------------------------------|-----------------|---|---|---|---|---|---|---|
| Register | 7 | 6 | 5 | 4 | 3 | 2 | 1 | 0 |
| Data | - | - | - | - | - | - | - | - |
| Error | ...See Below... | | | | | | | |
| Sector Count | - | - | - | - | - | - | - | - |
| Sector Number | - | - | - | - | - | - | - | - |
| Cylinder Low | - | - | - | - | - | - | - | - |
| Cylinder High | - | - | - | - | - | - | - | - |
| Device/Head | - | - | - | - | - | - | - | - |
| Status | ...See Below... | | | | | | | |

| Error Register | | | | | | | |
|----------------|-----|---|-----|---|-----|-----|-----|
| 7 | 6 | 5 | 4 | 3 | 2 | 1 | 0 |
| CRC | UNC | 0 | IDN | 0 | ABT | T0N | AMN |
| 0 | 0 | 0 | 0 | 0 | V | 0 | 0 |

| Status Register | | | | | | | |
|-----------------|-----|----|-----|-----|-----|-----|-----|
| 7 | 6 | 5 | 4 | 3 | 2 | 1 | 0 |
| BSY | RDY | DF | DSC | DRQ | COR | IDX | ERR |
| 0 | V | 0 | - | - | 0 | 0 | V |

Table 251 Trusted Send DMA Command (5Fh)

The Trusted Send DMA command writes one or more 512 byte packets to the drive. The content of the packets depend on the Security Protocol selected (feature). See Trusted Command Feature for details.

The host initializes a slave-DMA channel prior to issuing the command. The data transfers are qualified by DMARQ and are performed by the slave-DMA channel. The device issues only one interrupt per command to indicate that data transfer has terminated and status is available.

11.59 Write Buffer (E8h)

| Command Block Output Registers | | | | | | | | |
|--------------------------------|---|---|---|---|---|---|---|---|
| Register | 7 | 6 | 5 | 4 | 3 | 2 | 1 | 0 |
| Data | - | - | - | - | - | - | - | - |
| Feature | - | - | - | - | - | - | - | - |
| Sector Count | - | - | - | - | - | - | - | - |
| Sector Number | - | - | - | - | - | - | - | - |
| Cylinder Low | - | - | - | - | - | - | - | - |
| Cylinder High | - | - | - | - | - | - | - | - |
| Device/Head | 1 | - | 1 | D | - | - | - | - |
| Command | 1 | 1 | 1 | 0 | 1 | 0 | 0 | 0 |

| Command Block Input Registers | | | | | | | | |
|-------------------------------|-----------------|---|---|---|---|---|---|---|
| Register | 7 | 6 | 5 | 4 | 3 | 2 | 1 | 0 |
| Data | - | - | - | - | - | - | - | - |
| Error | ...See Below... | | | | | | | |
| Sector Count | - | - | - | - | - | - | - | - |
| Sector Number | - | - | - | - | - | - | - | - |
| Cylinder Low | - | - | - | - | - | - | - | - |
| Cylinder High | - | - | - | - | - | - | - | - |
| Device/Head | - | - | - | - | - | - | - | - |
| Status | ...See Below... | | | | | | | |

| Error Register | | | | | | | |
|----------------|-----|---|-----|---|-----|-----|-----|
| 7 | 6 | 5 | 4 | 3 | 2 | 1 | 0 |
| CRC | UNC | 0 | IDN | 0 | ABT | T0N | AMN |
| 0 | 0 | 0 | 0 | 0 | V | 0 | 0 |

| Status Register | | | | | | | |
|-----------------|-----|----|-----|-----|-----|-----|-----|
| 7 | 6 | 5 | 4 | 3 | 2 | 1 | 0 |
| BSY | RDY | DF | DSC | DRQ | COR | IDX | ERR |
| 0 | V | 0 | - | - | 0 | - | V |

Table 252 Write Buffer Command (E8h)

The Write Buffer command transfers a sector of data from the host to the sector buffer of the device. The sectors of data are transferred through the Data Register 16 bits at a time.

The Read Buffer and Write Buffer commands are synchronized such that sequential Write Buffer and Read Buffer commands access the same 512 byte within the buffer.

11.60 Write Buffer DMA (EBh)

| Command Block Output Registers | | | | | | | | |
|--------------------------------|---|---|---|---|---|---|---|---|
| Register | 7 | 6 | 5 | 4 | 3 | 2 | 1 | 0 |
| Data | - | - | - | - | - | - | - | - |
| Feature | - | - | - | - | - | - | - | - |
| Sector Count | - | - | - | - | - | - | - | - |
| Sector Number | - | - | - | - | - | - | - | - |
| Cylinder Low | - | - | - | - | - | - | - | - |
| Cylinder High | - | - | - | - | - | - | - | - |
| Device/Head | 1 | - | 1 | D | - | - | - | - |
| Command | 1 | 1 | 1 | 0 | 1 | 0 | 1 | 1 |

| Command Block Input Registers | | | | | | | | |
|-------------------------------|-----------------|---|---|---|---|---|---|---|
| Register | 7 | 6 | 5 | 4 | 3 | 2 | 1 | 0 |
| Data | - | - | - | - | - | - | - | - |
| Error | ...See Below... | | | | | | | |
| Sector Count | - | - | - | - | - | - | - | - |
| Sector Number | - | - | - | - | - | - | - | - |
| Cylinder Low | - | - | - | - | - | - | - | - |
| Cylinder High | - | - | - | - | - | - | - | - |
| Device/Head | - | - | - | - | - | - | - | - |
| Status | ...See Below... | | | | | | | |

| Error Register | | | | | | | |
|----------------|-----|---|-----|---|-----|-----|-----|
| 7 | 6 | 5 | 4 | 3 | 2 | 1 | 0 |
| CRC | UNC | 0 | IDN | 0 | ABT | T0N | AMN |
| 0 | 0 | 0 | 0 | 0 | V | 0 | 0 |

| Status Register | | | | | | | |
|-----------------|-----|----|-----|-----|-----|-----|-----|
| 7 | 6 | 5 | 4 | 3 | 2 | 1 | 0 |
| BSY | RDY | DF | DSC | DRQ | COR | IDX | ERR |
| 0 | V | 0 | - | - | 0 | - | V |

Table 253 Write Buffer DMA Command (EBh)

The Write Buffer DMA command transfers a sector of data from the host to the sector buffer of the device. The sectors of data are transferred through the Data Register 16 bits at a time.

The Read Buffer and Write Buffer commands are synchronized such that sequential Write Buffer and Read Buffer commands access the same 512 byte within the buffer.

11.61 Write DMA (CAh/CBh)

| Command Block Output Registers | | | | | | | | Command Block Input Registers | | | | | | | | | |
|--------------------------------|---|---|---|---|---|---|---|-------------------------------|---------------|-----------------|---|---|---|---|---|---|---|
| Register | 7 | 6 | 5 | 4 | 3 | 2 | 1 | 0 | Register | 7 | 6 | 5 | 4 | 3 | 2 | 1 | 0 |
| Data | - | - | - | - | - | - | - | - | Data | - | - | - | - | - | - | - | - |
| Feature | - | - | - | - | - | - | - | - | Error | ...See Below... | | | | | | | |
| Sector Count | V | V | V | V | V | V | V | V | Sector Count | V | V | V | V | V | V | V | V |
| Sector Number | V | V | V | V | V | V | V | V | Sector Number | V | V | V | V | V | V | V | V |
| Cylinder Low | V | V | V | V | V | V | V | V | Cylinder Low | V | V | V | V | V | V | V | V |
| Cylinder High | V | V | V | V | V | V | V | V | Cylinder High | V | V | V | V | V | V | V | V |
| Device/Head | 1 | L | 1 | D | H | H | H | H | Device/Head | - | - | - | - | H | H | H | H |
| Command | 1 | 1 | 0 | 0 | 1 | 0 | 1 | R | Status | ...See Below... | | | | | | | |

| Error Register | | | | | | | | Status Register | | | | | | | |
|----------------|-----|---|-----|---|-----|-----|-----|-----------------|-----|----|-----|-----|-----|-----|-----|
| 7 | 6 | 5 | 4 | 3 | 2 | 1 | 0 | 7 | 6 | 5 | 4 | 3 | 2 | 1 | 0 |
| CRC | UNC | 0 | IDN | 0 | ABT | T0N | AMN | BSY | RDY | DF | DSC | DRQ | COR | IDX | ERR |
| V | 0 | 0 | V | 0 | V | 0 | 0 | 0 | V | 0 | V | - | 0 | - | V |

Table 254 Write DMA Command (CAh/CBh)

The Write DMA command transfers one or more sectors of data from the host to the device, then the data is written to the disk media.

The sectors of data are transferred through the Data Register 16 bits at a time.

The host initializes a slave-DMA channel prior to issuing the command. Data transfers are qualified by DMARQ and are performed by the slave-DMA channel. The device issues only one interrupt per command to indicate that data transfer has terminated and status is available.

If an uncorrectable error occurs, the write will be terminated at the failing sector.

Output Parameters To The Device

Sector Count The number of continuous sectors to be transferred. If zero is specified, then 256 sectors will be transferred.

Sector Number The sector number of the first sector to be transferred. (L=0)
In LBA mode, this register contains LBA bits 0 – 7. (L=1)

Cylinder High/Low The cylinder number of the first sector to be transferred. (L=0)
In LBA mode, this register contains LBA bits 8 – 15 (Low), 16 – 23 (High). (L=1)

H The head number of the first sector to be transferred. (L=0)
In LBA mode, this register contains LBA bits 24 – 27. (L=1)

R The retry bit, but this bit is ignored.

Input Parameters From The Device

Sector Count The number of requested sectors not transferred. This will be zero, unless an unrecoverable error occurs.

Sector Number The sector number of the last transferred sector. (L=0)
In LBA mode, this register contains current LBA bits 0 – 7. (L=1)

Cylinder High/Low The cylinder number of the last transferred sector. (L=0)
In LBA mode, this register contains current LBA bits 8 – 15 (Low), 16 – 23 (High). (L=1)

H The head number of the last transferred sector. (L=0) In LBA mode, this register contains current LBA bits 24 – 27. (L=1)

11.62 Write DMA FUA Ext (3Dh)

| Command Block Output Registers | | | | | | | | |
|--------------------------------|----------|---|---|---|---|---|---|---|
| Register | 7 | 6 | 5 | 4 | 3 | 2 | 1 | 0 |
| Data Low | - | - | - | - | - | - | - | - |
| Data High | - | - | - | - | - | - | - | - |
| Feature | Current | - | - | - | - | - | - | - |
| | Previous | - | - | - | - | - | - | - |
| Sector Count | Current | V | V | V | V | V | V | V |
| | Previous | V | V | V | V | V | V | V |
| Sector Number | Current | V | V | V | V | V | V | V |
| | Previous | V | V | V | V | V | V | V |
| Cylinder Low | Current | V | V | V | V | V | V | V |
| | Previous | V | V | V | V | V | V | V |
| Cylinder High | Current | V | V | V | V | V | V | V |
| | Previous | V | V | V | V | V | V | V |
| Device/Head | - | 1 | - | D | - | - | - | - |
| Command | 0 | 0 | 1 | 1 | 1 | 1 | 0 | 1 |

| Command Block Input Registers | | | | | | | | |
|-------------------------------|-----------------|---|---|---|---|---|---|---|
| Register | 7 | 6 | 5 | 4 | 3 | 2 | 1 | 0 |
| Data Low | - | - | - | - | - | - | - | - |
| Data High | - | - | - | - | - | - | - | - |
| Error | ...See Below... | | | | | | | |
| Sector Count | HOB=0 | - | - | - | - | - | - | - |
| | HOB=1 | - | - | - | - | - | - | - |
| Sector Number | HOB=0 | V | V | V | V | V | V | V |
| | HOB=1 | V | V | V | V | V | V | V |
| Cylinder Low | HOB=0 | V | V | V | V | V | V | V |
| | HOB=1 | V | V | V | V | V | V | V |
| Cylinder High | HOB=0 | V | V | V | V | V | V | V |
| | HOB=1 | V | V | V | V | V | V | V |
| Device/Head | - | - | - | - | - | - | - | - |
| Status | ...See Below... | | | | | | | |

| Error Register | | | | | | | |
|----------------|-----|---|-----|---|-----|-----|-----|
| 7 | 6 | 5 | 4 | 3 | 2 | 1 | 0 |
| CRC | UNC | 0 | IDN | 0 | ABT | T0N | AMN |
| V | 0 | 0 | V | 0 | V | 0 | 0 |

| Status Register | | | | | | | |
|-----------------|-----|----|-----|-----|-----|-----|-----|
| 7 | 6 | 5 | 4 | 3 | 2 | 1 | 0 |
| BSY | RDY | DF | DSC | DRQ | COR | IDX | ERR |
| 0 | V | 0 | V | - | 0 | - | V |

Table 255 Write DMA FUA Ext Command (3Dh)

The Write DMA FUA Ext command transfers one or more sectors of data from the host to the device, and then the data is written to the disk media. This command provides the same function as the Write DMA Ext command except that the transferred data shall be written to the media before the ending status for this command is reported also when write caching is enabled.

The sectors of data are transferred through the Data Register 16 bits at a time.

The host initializes a slave-DMA channel prior to issuing the command. Data transfers are qualified by DMARQ and are performed by the slave-DMA channel. The device issues only one interrupt per command to indicate that data transfer has terminated and status is available.

If an unrecoverable error occurs, the write will be terminated at the failing sector.

Output Parameters To The Device

| | |
|-------------------------------|--|
| Sector Count Current | The number of continuous sectors to be transferred low order, bits (7:0). |
| Sector Count Previous | The number of continuous sectors to be transferred high order bits (15:8). If zero is specified in the Sector Count register, then 65,536 sectors will be transferred. |
| Sector Number Current | LBA (7:0). |
| Sector Number Previous | LBA (31:24). |
| Cylinder Low Current | LBA (15:8). |
| Cylinder Low Previous | LBA (39:32). |
| Cylinder High Current | LBA (23:16). |
| Cylinder High Previous | LBA (47:40). |

Input Parameters From The Device

| | |
|------------------------------|--|
| Sector Number (HOB=0) | LBA (7:0) of the address of the first unrecoverable error. |
| Sector Number (HOB=1) | LBA (31:24) of the address of the first unrecoverable error. |
| Cylinder Low (HOB=0) | LBA (15:8) of the address of the first unrecoverable error. |
| Cylinder Low (HOB=1) | LBA (39:32) of the address of the first unrecoverable error. |
| Cylinder High (HOB=0) | LBA (23:16) of the address of the first unrecoverable error. |
| Cylinder High (HOB=1) | LBA (47:40) of the address of the first unrecoverable error. |

11.63 Write DMA Ext (35h)

| Command Block Output Registers | | | | | | | | |
|--------------------------------|----------|---|---|---|---|---|---|---|
| Register | 7 | 6 | 5 | 4 | 3 | 2 | 1 | 0 |
| Data Low | - | - | - | - | - | - | - | - |
| Data High | - | - | - | - | - | - | - | - |
| Feature | Current | - | - | - | - | - | - | - |
| | Previous | - | - | - | - | - | - | - |
| Sector Count | Current | V | V | V | V | V | V | V |
| | Previous | V | V | V | V | V | V | V |
| Sector Number | Current | V | V | V | V | V | V | V |
| | Previous | V | V | V | V | V | V | V |
| Cylinder Low | Current | V | V | V | V | V | V | V |
| | Previous | V | V | V | V | V | V | V |
| Cylinder High | Current | V | V | V | V | V | V | V |
| | Previous | V | V | V | V | V | V | V |
| Device/Head | - | 1 | - | D | - | - | - | - |
| Command | 0 | 0 | 1 | 1 | 0 | 1 | 0 | 1 |

| Command Block Input Registers | | | | | | | | |
|-------------------------------|-----------------|---|---|---|---|---|---|---|
| Register | 7 | 6 | 5 | 4 | 3 | 2 | 1 | 0 |
| Data Low | - | - | - | - | - | - | - | - |
| Data High | - | - | - | - | - | - | - | - |
| Error | ...See Below... | | | | | | | |
| Sector Count | HOB=0 | - | - | - | - | - | - | - |
| | HOB=1 | - | - | - | - | - | - | - |
| Sector Number | HOB=0 | V | V | V | V | V | V | V |
| | HOB=1 | V | V | V | V | V | V | V |
| Cylinder Low | HOB=0 | V | V | V | V | V | V | V |
| | HOB=1 | V | V | V | V | V | V | V |
| Cylinder High | HOB=0 | V | V | V | V | V | V | V |
| | HOB=1 | V | V | V | V | V | V | V |
| Device/Head | - | - | - | - | - | - | - | - |
| Status | ...See Below... | | | | | | | |

| Error Register | | | | | | | |
|----------------|-----|---|-----|---|-----|-----|-----|
| 7 | 6 | 5 | 4 | 3 | 2 | 1 | 0 |
| CRC | UNC | 0 | IDN | 0 | ABT | TON | AMN |
| V | 0 | 0 | V | 0 | V | 0 | 0 |

| Status Register | | | | | | | |
|-----------------|-----|----|-----|-----|-----|-----|-----|
| 7 | 6 | 5 | 4 | 3 | 2 | 1 | 0 |
| BSY | RDY | DF | DSC | DRQ | COR | IDX | ERR |
| 0 | V | 0 | V | - | 0 | - | V |

Table 256 Write DMA Ext Command (35h)

The Write DMA Ext command transfers one or more sectors of data from the host to the device, and then the data is written to the disk media.

The sectors of data are transferred through the Data Register 16 bits at a time.

The host initializes a slave-DMA channel prior to issuing the command. Data transfers are qualified by DMARQ and are performed by the slave-DMA channel. The device issues only one interrupt per command to indicate that data transfer has terminated and status is available.

If an uncorrectable error occurs, the write will be terminated at the failing sector

Output Parameters To The Device

| | |
|-------------------------------|--|
| Sector Count Current | The number of continuous sectors to be transferred low order, bits (7:0). |
| Sector Count Previous | The number of continuous sectors to be transferred high order bits (15:8). If zero is specified in the Sector Count register, then 65,536 sectors will be transferred. |
| Sector Number Current | LBA (7:0). |
| Sector Number Previous | LBA (31:24). |
| Cylinder Low Current | LBA (15:8). |
| Cylinder Low Previous | LBA (39:32). |
| Cylinder High Current | LBA (23:16). |
| Cylinder High Previous | LBA (47:40). |

Input Parameters From The Device

| | |
|------------------------------|--|
| Sector Number (HOB=0) | LBA (7:0) of the address of the first unrecoverable error. |
| Sector Number (HOB=1) | LBA (31:24) of the address of the first unrecoverable error. |
| Cylinder Low (HOB=0) | LBA (15:8) of the address of the first unrecoverable error. |
| Cylinder Low (HOB=1) | LBA (39:32) of the address of the first unrecoverable error. |
| Cylinder High (HOB=0) | LBA (23:16) of the address of the first unrecoverable error. |
| Cylinder High (HOB=1) | LBA (47:40) of the address of the first unrecoverable error. |

11.64 Write FPDMA Queued (61h)

| Command Block Output Registers | | | | | | | | |
|--------------------------------|----------|---|---|---|---|---|---|---|
| Register | 7 | 6 | 5 | 4 | 3 | 2 | 1 | 0 |
| Data Low | - | - | - | - | - | - | - | - |
| Data High | - | - | - | - | - | - | - | - |
| Feature | Current | V | V | V | V | V | V | V |
| | Previous | V | V | V | V | V | V | V |
| Sector Count | Current | V | V | V | V | - | - | - |
| | Previous | - | - | - | - | - | - | - |
| Sector Number | Current | V | V | V | V | V | V | V |
| | Previous | V | V | V | V | V | V | V |
| Cylinder Low | Current | V | V | V | V | V | V | V |
| | Previous | V | V | V | V | V | V | V |
| Cylinder High | Current | V | V | V | V | V | V | V |
| | Previous | V | V | V | V | V | V | V |
| Device/Head | V | 1 | - | 0 | - | - | - | - |
| Command | 0 | 1 | 1 | 0 | 0 | 0 | 0 | 1 |

| Command Block Input Registers | | | | | | | | |
|-------------------------------|-----------------|---|---|---|---|---|---|---|
| Register | 7 | 6 | 5 | 4 | 3 | 2 | 1 | 0 |
| Data Low | - | - | - | - | - | - | - | - |
| Data High | - | - | - | - | - | - | - | - |
| Error | ...See Below... | | | | | | | |
| Sector Count | HOB=0 | - | - | - | - | - | - | - |
| | HOB=1 | - | - | - | - | - | - | - |
| Sector Number | HOB=0 | V | V | V | V | V | V | V |
| | HOB=1 | V | V | V | V | V | V | V |
| Cylinder Low | HOB=0 | V | V | V | V | V | V | V |
| | HOB=1 | V | V | V | V | V | V | V |
| Cylinder High | HOB=0 | V | V | V | V | V | V | V |
| | HOB=1 | V | V | V | V | V | V | V |
| Device/Head | - | - | - | - | - | - | - | - |
| Status | ...See Below... | | | | | | | |

| Error Register | | | | | | | |
|----------------|-----|---|-----|---|-----|-----|-----|
| 7 | 6 | 5 | 4 | 3 | 2 | 1 | 0 |
| CRC | UNC | 0 | IDN | 0 | ABT | T0N | AMN |
| V | 0 | 0 | V | 0 | V | 0 | 0 |

| Status Register | | | | | | | |
|-----------------|-----|----|-----|-----|-----|-----|-----|
| 7 | 6 | 5 | 4 | 3 | 2 | 1 | 0 |
| BSY | RDY | DF | DSC | DRQ | COR | IDX | ERR |
| 0 | V | 0 | V | - | 0 | - | V |

Table 257 Write FPDMA Queued Command (61h)

The Write FPDMA Queued command transfers one or more sectors of data from the host to the device, and then the data is written to the disk media.

If an unrecoverable error occurs, the write will be terminated at the failing sector

Output Parameters To The Device

Feature Current The number of sectors to be transferred low order, bits (7:0).

Feature Previous The number of sectors to be transferred high order, bits (15:8).

Sector Count Current .

TAG (bits 7-3) The TAG value shall be assigned to be different from all other queued commands. The value shall not exceed the maximum queue depth specified by the Word 75 of the Identify Device information.

Sector Count Previous

PRIO (bits 7-6) The Priority (PRIO) value shall be assigned by the host based on the priority of the command issued. The device makes a best effort to complete High priority requests in a more timely fashion than Normal and isochronous priority requests. The device tries to complete isochronous requests prior to its associated deadline. The Priority values are defined as follows:

00b Normal priority

01b Isochronous – deadline dependent priority

10b High priority

Sector Number Current LBA (7:0)

Sector Number Previous LBA (31:24)

Cylinder Low Current LBA (15:8)

Cylinder Low Previous LBA (39:32)
Cylinder High Current LBA (23:16)
Cylinder High Previous LBA (47:40)
ICC The Isochronous Command Completion (ICC) field is valid when PRIO is set to a value of 01b. It is assigned by the host based on the intended deadline associated with the command issued. When a deadline has expired, the device continues to complete the command as soon as possible. The host can modify this behavior if the device supports the NCQ NON-DATA command (see 11.15 NCQ NON-DATA (63h)) and supports the Deadline Handling subcommand (see 11.15.2 Deadline Handling Subcommand (1h)). This subcommand allows the host to set whether the device aborts commands that have exceeded the time set in ICC.

There are several parameters encoded in the ICC field: Fine or Coarse timing, Interval and the Max Time. The Interval indicates the time units of the Time Limit parameter.

If ICC Bit 7 cleared to zero, then the time interval is fine-grained.

Interval = 10msec
Time Limit = (ICC[6:0] + 1) * 10 msec

If ICC Bit 7 is set to one (coarse encoding), then the time interval is coarse grained.

Interval = 0.5 sec
Time Limit = (ICC[6:0] + 1) * 0.5 sec

Device/Head

FUA (bit 7) When the FUA bit is set to 1, the completion status is indicated after the transferred data are written to the media also when Write Cache is enabled.

When the FUA bit is set to 0, the completion status may be indicated before the transferred data are written to the media successfully when Write Cache is enabled.

Input Parameters From The Device

Sector Number (HOB=0) LBA (7:0) of the address of the first unrecoverable error.
Sector Number (HOB=1) LBA (31:24) of the address of the first unrecoverable error.
Cylinder Low (HOB=0) LBA (15:8) of the address of the first unrecoverable error.
Cylinder Low (HOB=1) LBA (39:32) of the address of the first unrecoverable error.
Cylinder High (HOB=0) LBA (23:16) of the address of the first unrecoverable error.
Cylinder High (HOB=1) LBA (47:40) of the address of the first unrecoverable error.

11.65 Write Log Ext (3Fh)

| Command Block Output Registers | | | | | | | | |
|--------------------------------|----------|---|---|---|---|---|---|---|
| Register | 7 | 6 | 5 | 4 | 3 | 2 | 1 | 0 |
| Data Low | - | - | - | - | - | - | - | - |
| Data High | - | - | - | - | - | - | - | - |
| Feature | Current | - | - | - | - | - | - | - |
| | Previous | - | - | - | - | - | - | - |
| Sector Count | Current | V | V | V | V | V | V | V |
| | Previous | V | V | V | V | V | V | V |
| Sector Number | Current | V | V | V | V | V | V | V |
| | Previous | - | - | - | - | - | - | - |
| Cylinder Low | Current | V | V | V | V | V | V | V |
| | Previous | V | V | V | V | V | V | V |
| Cylinder High | Current | - | - | - | - | - | - | - |
| | Previous | - | - | - | - | - | - | - |
| Device/Head | 1 | - | 1 | D | - | - | - | - |
| Command | 0 | 0 | 1 | 1 | 1 | 1 | 1 | 1 |

| Command Block Input Registers | | | | | | | | |
|-------------------------------|-----------------|---|---|---|---|---|---|---|
| Register | 7 | 6 | 5 | 4 | 3 | 2 | 1 | 0 |
| Data Low | - | - | - | - | - | - | - | - |
| Data High | - | - | - | - | - | - | - | - |
| Error | ...See Below... | | | | | | | |
| Sector Count | HOB=0 | - | - | - | - | - | - | - |
| | HOB=1 | - | - | - | - | - | - | - |
| Sector Number | HOB=0 | - | - | - | - | - | - | - |
| | HOB=1 | - | - | - | - | - | - | - |
| Cylinder Low | HOB=0 | - | - | - | - | - | - | - |
| | HOB=1 | - | - | - | - | - | - | - |
| Cylinder High | HOB=0 | - | - | - | - | - | - | - |
| | HOB=1 | - | - | - | - | - | - | - |
| Device/Head | - | - | - | - | - | - | - | - |
| Status | ...See Below... | | | | | | | |

| Error Register | | | | | | | |
|----------------|-----|---|-----|---|-----|-----|-----|
| 7 | 6 | 5 | 4 | 3 | 2 | 1 | 0 |
| CRC | UNC | 0 | IDN | 0 | ABT | T0N | AMN |
| 0 | V | 0 | V | 0 | V | 0 | 0 |

| Status Register | | | | | | | |
|-----------------|-----|----|-----|-----|-----|-----|-----|
| 7 | 6 | 5 | 4 | 3 | 2 | 1 | 0 |
| BSY | RDY | DF | DSC | DRQ | COR | IDX | ERR |
| 0 | V | 0 | V | - | 0 | - | V |

Table 258 Write Log Ext Command (3Fh)

This command writes a specified number of 512 byte data sectors to the specific log. The device shall interrupt for each DRQ block transferred.

Output Parameters To The Device

- Sector Count Current** The number of sectors to be written to the specified log low order, bits (7:0).
- Sector Count Previous** The number of sectors to be written to the specified log high orders, bits (15:8). If the number of sectors is greater than the number indicated in the Log directory, which is available in Log number zero, the device shall return command aborted. The log transferred to the device shall be stored by the device starting at the first sector in the specified log.
- Sector Number Current** The log to be written as described in Table 143 Log address definition. If the host attempts to write to a read only log address, the device shall return command aborted.
- Cylinder Low Current** The first sector of the log to be written low order, bits (7:0).
- Cylinder Low Previous** The first sector of the log to be written high order, bits (15:8).

If the feature set associated with the log specified in the Sector Number register is not supported or enabled, or if the values in the Sector Count, Sector Number or Cylinder Low registers are invalid, the device shall return command aborted. If the host attempts to write to a read only log address, the device shall return command aborted.

11.66 Write Log DMA Ext (57h)

| Command Block Output Registers | | | | | | | | |
|--------------------------------|----------|---|---|---|---|---|---|---|
| Register | 7 | 6 | 5 | 4 | 3 | 2 | 1 | 0 |
| Data Low | - | - | - | - | - | - | - | - |
| Data High | - | - | - | - | - | - | - | - |
| Feature | Current | - | - | - | - | - | - | - |
| | Previous | - | - | - | - | - | - | - |
| Sector Count | Current | V | V | V | V | V | V | V |
| | Previous | V | V | V | V | V | V | V |
| LBA Low | Current | V | V | V | V | V | V | V |
| | Previous | - | - | - | - | - | - | - |
| LBA Mid | Current | V | V | V | V | V | V | V |
| | Previous | V | V | V | V | V | V | V |
| LBA High | Current | - | - | - | - | - | - | - |
| | Previous | - | - | - | - | - | - | - |
| Device | - | - | - | - | - | - | - | - |
| Command | 0 | 1 | 0 | 1 | 0 | 1 | 1 | 1 |

| Command Block Input Registers | | | | | | | | |
|-------------------------------|-----------------|---|---|---|---|---|---|---|
| Register | 7 | 6 | 5 | 4 | 3 | 2 | 1 | 0 |
| Data Low | - | - | - | - | - | - | - | - |
| Data High | - | - | - | - | - | - | - | - |
| Error | ...See Below... | | | | | | | |
| Sector Count | HOB=0 | - | - | - | - | - | - | - |
| | HOB=1 | - | - | - | - | - | - | - |
| LBA Low | HOB=0 | - | - | - | - | - | - | - |
| | HOB=1 | - | - | - | - | - | - | - |
| LBA Mid | HOB=0 | - | - | - | - | - | - | - |
| | HOB=1 | - | - | - | - | - | - | - |
| LBA High | HOB=0 | - | - | - | - | - | - | - |
| | HOB=1 | - | - | - | - | - | - | - |
| Device | - | - | - | - | - | - | - | - |
| Status | ...See Below... | | | | | | | |

| Error Register | | | | | | | |
|----------------|-----|---|-----|---|-----|-----|-----|
| 7 | 6 | 5 | 4 | 3 | 2 | 1 | 0 |
| CRC | UNC | 0 | IDN | 0 | ABT | T0N | AMN |
| V | V | 0 | V | 0 | V | 0 | 0 |

| Status Register | | | | | | | |
|-----------------|-----|----|-----|-----|-----|-----|-----|
| 7 | 6 | 5 | 4 | 3 | 2 | 1 | 0 |
| BSY | RDY | DF | DSC | DRQ | COR | IDX | ERR |
| 0 | V | 0 | V | - | 0 | 0 | V |

Table 259 Write Log DMA Ext Command (57h)

The content of this command is the same as Write Log Ext. See 11.65 Write Log Ext (3Fh)

11.67 Write Multiple (C5h)

| Command Block Output Registers | | | | | | | | |
|--------------------------------|---|---|---|---|---|---|---|---|
| Register | 7 | 6 | 5 | 4 | 3 | 2 | 1 | 0 |
| Data | - | - | - | - | - | - | - | - |
| Feature | - | - | - | - | - | - | - | - |
| Sector Count | V | V | V | V | V | V | V | V |
| Sector Number | V | V | V | V | V | V | V | V |
| Cylinder Low | V | V | V | V | V | V | V | V |
| Cylinder High | V | V | V | V | V | V | V | V |
| Device/Head | 1 | L | 1 | D | H | H | H | H |
| Command | 1 | 1 | 0 | 0 | 0 | 1 | 0 | 1 |

| Command Block Input Registers | | | | | | | | |
|-------------------------------|-----------------|---|---|---|---|---|---|---|
| Register | 7 | 6 | 5 | 4 | 3 | 2 | 1 | 0 |
| Data | - | - | - | - | - | - | - | - |
| Error | ...See Below... | | | | | | | |
| Sector Count | V | V | V | V | V | V | V | V |
| Sector Number | V | V | V | V | V | V | V | V |
| Cylinder Low | V | V | V | V | V | V | V | V |
| Cylinder High | V | V | V | V | V | V | V | V |
| Device/Head | - | - | - | - | H | H | H | H |
| Status | ...See Below... | | | | | | | |

| Error Register | | | | | | | |
|----------------|-----|---|-----|---|-----|-----|-----|
| 7 | 6 | 5 | 4 | 3 | 2 | 1 | 0 |
| CRC | UNC | 0 | IDN | 0 | ABT | T0N | AMN |
| 0 | 0 | 0 | V | 0 | V | 0 | 0 |

| Status Register | | | | | | | |
|-----------------|-----|----|-----|-----|-----|-----|-----|
| 7 | 6 | 5 | 4 | 3 | 2 | 1 | 0 |
| BSY | RDY | DF | DSC | DRQ | COR | IDX | ERR |
| 0 | V | 0 | V | - | 0 | - | V |

Table 260 Write Multiple Command (C5h)

The Write Multiple command transfers one or more sectors from the host to the device, and then the data is written to the disk media.

Command execution is identical to the Write Sector(s) command except that an interrupt is generated for each block (as defined by the Set Multiple command) instead of for each sector. The sectors are transferred through the Data Register 16 bits at a time.

Output Parameters To The Device

- Sector Count** The number of continuous sectors to be transferred. If zero is specified, then 256 sectors will be transferred.
- Sector Number** The sector number of the first sector to be transferred. (L=0)
In LBA mode, this register contains LBA bits 0 - 7. (L=1)
- Cylinder High/Low** The cylinder number of the first sector to be transferred. (L=0)
In LBA mode, this register contains LBA bits 8 - 15 (Low), 16 - 23 (High). (L=1)
- H** The head number of the first sector to be transferred. (L=0)
In LBA mode, this register contains LBA bits 24 - 27. (L=1)

Input Parameters From The Device

- Sector Count** The number of requested sectors not transferred. This will be zero, unless an unrecoverable error occurs.
- Sector Number** The sector number of the last transferred sector. (L=0)
In LBA mode, this register contains current LBA bits 0 - 7. (L=1)
- Cylinder High/Low** The cylinder number of the last transferred sector. (L=0)
In LBA mode, this register contains current LBA bits 8 - 15 (Low), 16 - 23 (High). (L=1)
- H** The head number of the last transferred sector. (L=0)
In LBA mode, this register contains current LBA bits 24 - 27. (L=1)

11.68 Write Multiple Ext (39h)

| Command Block Output Registers | | | | | | | | |
|--------------------------------|----------|---|---|---|---|---|---|---|
| Register | 7 | 6 | 5 | 4 | 3 | 2 | 1 | 0 |
| Data Low | - | - | - | - | - | - | - | - |
| Data High | - | - | - | - | - | - | - | - |
| Feature | Current | - | - | - | - | - | - | - |
| | Previous | - | - | - | - | - | - | - |
| Sector Count | Current | V | V | V | V | V | V | V |
| | Previous | V | V | V | V | V | V | V |
| Sector Number | Current | V | V | V | V | V | V | V |
| | Previous | V | V | V | V | V | V | V |
| Cylinder Low | Current | V | V | V | V | V | V | V |
| | Previous | V | V | V | V | V | V | V |
| Cylinder High | Current | V | V | V | V | V | V | V |
| | Previous | V | V | V | V | V | V | V |
| Device/Head | - | 1 | - | D | - | - | - | - |
| Command | 0 | 0 | 1 | 1 | 1 | 0 | 0 | 1 |

| Command Block Input Registers | | | | | | | | |
|-------------------------------|-----------------|---|---|---|---|---|---|---|
| Register | 7 | 6 | 5 | 4 | 3 | 2 | 1 | 0 |
| Data Low | - | - | - | - | - | - | - | - |
| Data High | - | - | - | - | - | - | - | - |
| Error | ...See Below... | | | | | | | |
| Sector Count | HOB=0 | - | - | - | - | - | - | - |
| | HOB=1 | - | - | - | - | - | - | - |
| Sector Number | HOB=0 | V | V | V | V | V | V | V |
| | HOB=1 | V | V | V | V | V | V | V |
| Cylinder Low | HOB=0 | V | V | V | V | V | V | V |
| | HOB=1 | V | V | V | V | V | V | V |
| Cylinder High | HOB=0 | V | V | V | V | V | V | V |
| | HOB=1 | V | V | V | V | V | V | V |
| Device/Head | - | - | - | - | - | - | - | - |
| Status | ...See Below... | | | | | | | |

| Error Register | | | | | | | |
|----------------|-----|---|-----|---|-----|-----|-----|
| 7 | 6 | 5 | 4 | 3 | 2 | 1 | 0 |
| CRC | UNC | 0 | IDN | 0 | ABT | T0N | AMN |
| 0 | 0 | 0 | V | 0 | V | 0 | 0 |

| Status Register | | | | | | | |
|-----------------|-----|----|-----|-----|-----|-----|-----|
| 7 | 6 | 5 | 4 | 3 | 2 | 1 | 0 |
| BSY | RDY | DF | DSC | DRQ | COR | IDX | ERR |
| 0 | V | 0 | V | - | 0 | - | V |

Table 261 Write Multiple Ext Command (39h)

The Write Multiple Ext command transfers one or more sectors from the host to the device, and then the data is written to the disk media.

Command execution is identical to the Write Sector(s) Ext command except that an interrupt is generated for each block (as defined by the Set Multiple command) instead of for each sector. The sectors are transferred through the Data Register 16 bits at a time.

Output Parameters To The Device

| | |
|-------------------------------|--|
| Sector Count Current | The number of continuous sectors to be transferred low order, bits (7:0) |
| Sector Count Previous | The number of continuous sectors to be transferred high order, bits (15:8). If zero is specified in the Sector Count register, then 65,536 sectors shall be transferred. |
| Sector Number Current | LBA (7:0). |
| Sector Number Previous | LBA (31:24). |
| Cylinder Low Current | LBA (15:8). |
| Cylinder Low Previous | LBA (39:32). |
| Cylinder High Current | LBA (23:16). |
| Cylinder High Previous | LBA (47:40). |

Input Parameters From The Device

| | |
|------------------------------|--|
| Sector Number (HOB=0) | LBA (7:0) of the address of the first unrecoverable error. |
| Sector Number (HOB=1) | LBA (31:24) of the address of the first unrecoverable error. |
| Cylinder Low (HOB=0) | LBA (15:8) of the address of the first unrecoverable error. |
| Cylinder Low (HOB=1) | LBA (39:32) of the address of the first unrecoverable error. |
| Cylinder High (HOB=0) | LBA (23:16) of the address of the first unrecoverable error. |
| Cylinder High (HOB=1) | LBA (47:40) of the address of the first unrecoverable error. |

11.69 Write Multiple FUA Ext (CEh)

| Command Block Output Registers | | | | | | | | |
|--------------------------------|----------|---|---|---|---|---|---|---|
| Register | 7 | 6 | 5 | 4 | 3 | 2 | 1 | 0 |
| Data Low | - | - | - | - | - | - | - | - |
| Data High | - | - | - | - | - | - | - | - |
| Feature | Current | - | - | - | - | - | - | - |
| | Previous | - | - | - | - | - | - | - |
| Sector Count | Current | V | V | V | V | V | V | V |
| | Previous | V | V | V | V | V | V | V |
| Sector Number | Current | V | V | V | V | V | V | V |
| | Previous | V | V | V | V | V | V | V |
| Cylinder Low | Current | V | V | V | V | V | V | V |
| | Previous | V | V | V | V | V | V | V |
| Cylinder High | Current | V | V | V | V | V | V | V |
| | Previous | V | V | V | V | V | V | V |
| Device/Head | - | 1 | - | D | - | - | - | - |
| Command | 1 | 1 | 0 | 0 | 1 | 1 | 1 | 0 |

| Command Block Input Registers | | | | | | | | |
|-------------------------------|-----------------|---|---|---|---|---|---|---|
| Register | 7 | 6 | 5 | 4 | 3 | 2 | 1 | 0 |
| Data Low | - | - | - | - | - | - | - | - |
| Data High | - | - | - | - | - | - | - | - |
| Error | ...See Below... | | | | | | | |
| Sector Count | HOB=0 | - | - | - | - | - | - | - |
| | HOB=1 | - | - | - | - | - | - | - |
| Sector Number | HOB=0 | V | V | V | V | V | V | V |
| | HOB=1 | V | V | V | V | V | V | V |
| Cylinder Low | HOB=0 | V | V | V | V | V | V | V |
| | HOB=1 | V | V | V | V | V | V | V |
| Cylinder High | HOB=0 | V | V | V | V | V | V | V |
| | HOB=1 | V | V | V | V | V | V | V |
| Device/Head | - | - | - | - | - | - | - | - |
| Status | ...See Below... | | | | | | | |

| Error Register | | | | | | | |
|----------------|-----|---|-----|---|-----|-----|-----|
| 7 | 6 | 5 | 4 | 3 | 2 | 1 | 0 |
| CRC | UNC | 0 | IDN | 0 | ABT | TON | AMN |
| 0 | 0 | 0 | V | 0 | V | 0 | 0 |

| Status Register | | | | | | | |
|-----------------|-----|----|-----|-----|-----|-----|-----|
| 7 | 6 | 5 | 4 | 3 | 2 | 1 | 0 |
| BSY | RDY | DF | DSC | DRQ | COR | IDX | ERR |
| 0 | V | 0 | V | - | 0 | - | V |

Table 262 Write Multiple FUA Ext Command (CEh)

The Write Multiple Ext command transfers one or more sectors from the host to the device, and then the data is written to the disk media. This command provides the same function as the Write Multiple Ext command except that the transferred data shall be written to the media before the ending status for this command is reported also when write caching is enabled.

Command execution is identical to the Write Sector(s) Ext command except that an interrupt is generated for each block (as defined by the Set Multiple command) instead of for each sector. The sectors are transferred through the Data Register 16 bits at a time.

Output Parameters To The Device

| | |
|-------------------------------|--|
| Sector Count Current | The number of continuous sectors to be transferred low order, bits (7:0) |
| Sector Count Previous | The number of continuous sectors to be transferred high order, bits (15:8). If zero is specified in the Sector Count register, then 65,536 sectors shall be transferred. |
| Sector Number Current | LBA (7:0). |
| Sector Number Previous | LBA (31:24). |
| Cylinder Low Current | LBA (15:8). |
| Cylinder Low Previous | LBA (39:32). |
| Cylinder High Current | LBA (23:16). |
| Cylinder High Previous | LBA (47:40). |

Input Parameters From The Device

| | |
|------------------------------|--|
| Sector Number (HOB=0) | LBA (7:0) of the address of the first unrecoverable error. |
| Sector Number (HOB=1) | LBA (31:24) of the address of the first unrecoverable error. |
| Cylinder Low (HOB=0) | LBA (15:8) of the address of the first unrecoverable error. |

| | |
|------------------------------|--|
| Cylinder Low (HOB=1) | LBA (39:32) of the address of the first unrecoverable error. |
| Cylinder High (HOB=0) | LBA (23:16) of the address of the first unrecoverable error. |
| Cylinder High (HOB=1) | LBA (47:40) of the address of the first unrecoverable error. |

11.70 Write Sector(s) (30h/31h)

| Command Block Output Registers | | | | | | | | |
|--------------------------------|---|---|---|---|---|---|---|---|
| Register | 7 | 6 | 5 | 4 | 3 | 2 | 1 | 0 |
| Data | - | - | - | - | - | - | - | - |
| Feature | - | - | - | - | - | - | - | - |
| Sector Count | V | V | V | V | V | V | V | V |
| Sector Number | V | V | V | V | V | V | V | V |
| Cylinder Low | V | V | V | V | V | V | V | V |
| Cylinder High | V | V | V | V | V | V | V | V |
| Device/Head | 1 | L | 1 | D | H | H | H | H |
| Command | 0 | 0 | 1 | 1 | 0 | 0 | 0 | R |

| Command Block Input Registers | | | | | | | | |
|-------------------------------|-----------------|---|---|---|---|---|---|---|
| Register | 7 | 6 | 5 | 4 | 3 | 2 | 1 | 0 |
| Data | - | - | - | - | - | - | - | - |
| Error | ...See Below... | | | | | | | |
| Sector Count | V | V | V | V | V | V | V | V |
| Sector Number | V | V | V | V | V | V | V | V |
| Cylinder Low | V | V | V | V | V | V | V | V |
| Cylinder High | V | V | V | V | V | V | V | V |
| Device/Head | - | - | - | - | H | H | H | H |
| Status | ...See Below... | | | | | | | |

| Error Register | | | | | | | |
|----------------|-----|---|-----|---|-----|-----|-----|
| 7 | 6 | 5 | 4 | 3 | 2 | 1 | 0 |
| CRC | UNC | 0 | IDN | 0 | ABT | T0N | AMN |
| 0 | 0 | 0 | V | 0 | V | 0 | 0 |

| Status Register | | | | | | | |
|-----------------|-----|----|-----|-----|-----|-----|-----|
| 7 | 6 | 5 | 4 | 3 | 2 | 1 | 0 |
| BSY | RDY | DF | DSC | DRQ | COR | IDX | ERR |
| 0 | V | 0 | V | - | 0 | - | V |

Table 263 Write Sector(s) Command (30h/31h)

The Write Sector(s) command transfers one or more sectors from the host to the device, and then the data is written to the disk media.

The sectors are transferred through the Data Register 16 bits at a time.

If an uncorrectable error occurs, the write will be terminated at the failing sector.

Output Parameters To The Device

- Sector Count** The number of continuous sectors to be transferred. If zero is specified, then 256 sectors will be transferred.
- Sector Number** The sector number of the first sector to be transferred. (L=0)
In LBA mode, this register contains LBA bits 0 - 7. (L=1)
- Cylinder High/Low** The cylinder number of the first sector to be transferred. (L=0)
In LBA mode, this register contains LBA bits 8 - 15 (Low), 16 - 23 (High). (L=1)
- H** The head number of the first sector to be transferred. (L=0)
In LBA mode, this register contains LBA bits 24 - 27. (L=1)
- R** The retry bit, but this bit is ignored.

Input Parameters From The Device

- Sector Count** The number of requested sectors not transferred. This will be zero, unless an unrecoverable error occurs.
- Sector Number** The sector number of the last transferred sector. (L=0)
In LBA mode, this register contains current LBA bits 0 - 7. (L=1)
- Cylinder High/Low** The cylinder number of the last transferred sector. (L=0)
In LBA mode, this register contains current LBA bits 8 - 15 (Low), 16 - 23 (High). (L=1)
- H** The head number of the last transferred sector. (L=0)
In LBA mode, this register contains current LBA bits 24 - 27. (L=1)

11.71 Write Sector(s) Ext (34h)

| Command Block Output Registers | | | | | | | | |
|--------------------------------|----------|---|---|---|---|---|---|---|
| Register | 7 | 6 | 5 | 4 | 3 | 2 | 1 | 0 |
| Data Low | - | - | - | - | - | - | - | - |
| Data High | - | - | - | - | - | - | - | - |
| Feature | Current | - | - | - | - | - | - | - |
| | Previous | - | - | - | - | - | - | - |
| Sector Count | Current | V | V | V | V | V | V | V |
| | Previous | V | V | V | V | V | V | V |
| Sector Number | Current | V | V | V | V | V | V | V |
| | Previous | V | V | V | V | V | V | V |
| Cylinder Low | Current | V | V | V | V | V | V | V |
| | Previous | V | V | V | V | V | V | V |
| Cylinder High | Current | V | V | V | V | V | V | V |
| | Previous | V | V | V | V | V | V | V |
| Device/Head | - | 1 | - | D | - | - | - | - |
| Command | 0 | 0 | 1 | 1 | 0 | 1 | 0 | 0 |

| Command Block Input Registers | | | | | | | | |
|-------------------------------|-----------------|---|---|---|---|---|---|---|
| Register | 7 | 6 | 5 | 4 | 3 | 2 | 1 | 0 |
| Data Low | - | - | - | - | - | - | - | - |
| Data High | - | - | - | - | - | - | - | - |
| Error | ...See Below... | | | | | | | |
| Sector Count | HOB=0 | - | - | - | - | - | - | - |
| | HOB=1 | - | - | - | - | - | - | - |
| Sector Number | HOB=0 | V | V | V | V | V | V | V |
| | HOB=1 | V | V | V | V | V | V | V |
| Cylinder Low | HOB=0 | V | V | V | V | V | V | V |
| | HOB=1 | V | V | V | V | V | V | V |
| Cylinder High | HOB=0 | V | V | V | V | V | V | V |
| | HOB=1 | V | V | V | V | V | V | V |
| Device/Head | - | - | - | - | - | - | - | - |
| Status | ...See Below... | | | | | | | |

| Error Register | | | | | | | |
|----------------|-----|---|-----|---|-----|-----|-----|
| 7 | 6 | 5 | 4 | 3 | 2 | 1 | 0 |
| CRC | UNC | 0 | IDN | 0 | ABT | T0N | AMN |
| 0 | 0 | 0 | V | 0 | V | 0 | 0 |

| Status Register | | | | | | | |
|-----------------|-----|----|-----|-----|-----|-----|-----|
| 7 | 6 | 5 | 4 | 3 | 2 | 1 | 0 |
| BSY | RDY | DF | DSC | DRQ | COR | IDX | ERR |
| 0 | V | 0 | V | - | 0 | - | V |

Table 264 Write Sector(s) Ext Command (34h)

The Write Sector(s) Ext command transfers one or more sectors from the host to the device, and then the data is written to the disk media.

The sectors are transferred through the Data Register 16 bits at a time.

If an uncorrectable error occurs, the write will be terminated at the failing sector.

Output Parameters To The Device

| | |
|-------------------------------|---|
| Sector Count Current | The number of continuous sectors to be transferred low order, bits (7:0). |
| Sector Count Previous | The number of continuous sectors to be transferred high order bits (15:8). If zero is specified, then 65,536 sectors will be transferred. |
| Sector Number Current | LBA (7:0). |
| Sector Number Previous | LBA (31:24). |
| Cylinder Low Current | LBA (15:8). |
| Cylinder Low Previous | LBA (39:32). |
| Cylinder High Current | LBA (23:16). |
| Cylinder High Previous | LBA (47:40). |

Input Parameters From The Device

| | |
|------------------------------|--|
| Sector Number (HOB=0) | LBA (7:0) of the address of the first unrecoverable error. |
| Sector Number (HOB=1) | LBA (31:24) of the address of the first unrecoverable error. |
| Cylinder Low (HOB=0) | LBA (15:8) of the address of the first unrecoverable error. |
| Cylinder Low (HOB=1) | LBA (39:32) of the address of the first unrecoverable error. |
| Cylinder High (HOB=0) | LBA (23:16) of the address of the first unrecoverable error. |
| Cylinder High (HOB=1) | LBA (47:40) of the address of the first unrecoverable error. |

11.72 Write Stream DMA Ext (3Ah)

| Command Block Output Registers | | | | | | | | |
|--------------------------------|----------|---|---|---|---|---|---|---|
| Register | 7 | 6 | 5 | 4 | 3 | 2 | 1 | 0 |
| Data Low | - | - | - | - | - | - | - | - |
| Data High | - | - | - | - | - | - | - | - |
| Feature | Current | V | V | V | V | - | V | V |
| | Previous | V | V | V | V | V | V | V |
| Sector Count | Current | V | V | V | V | V | V | V |
| | Previous | V | V | V | V | V | V | V |
| Sector Number | Current | V | V | V | V | V | V | V |
| | Previous | V | V | V | V | V | V | V |
| Cylinder Low | Current | V | V | V | V | V | V | V |
| | Previous | V | V | V | V | V | V | V |
| Cylinder High | Current | V | V | V | V | V | V | V |
| | Previous | V | V | V | V | V | V | V |
| Device/Head | 1 | 1 | 1 | D | - | - | - | - |
| Command | 0 | 0 | 1 | 1 | 1 | 0 | 1 | 0 |

| Command Block Input Registers | | | | | | | | |
|-------------------------------|-----------------|---|---|---|---|---|---|---|
| Register | 7 | 6 | 5 | 4 | 3 | 2 | 1 | 0 |
| Data Low | - | - | - | - | - | - | - | - |
| Data High | - | - | - | - | - | - | - | - |
| Error | ...See Below... | | | | | | | |
| Sector Count | HOB=0 | - | - | - | - | - | - | - |
| | HOB=1 | - | - | - | - | - | - | - |
| Sector Number | HOB=0 | V | V | V | V | V | V | V |
| | HOB=1 | V | V | V | V | V | V | V |
| Cylinder Low | HOB=0 | V | V | V | V | V | V | V |
| | HOB=1 | V | V | V | V | V | V | V |
| Cylinder High | HOB=0 | V | V | V | V | V | V | V |
| | HOB=1 | V | V | V | V | V | V | V |
| Device/Head | - | - | - | - | - | - | - | - |
| Status | ...See Below... | | | | | | | |

| Error Register | | | | | | | |
|----------------|-----|---|-----|---|-----|-----|------|
| 7 | 6 | 5 | 4 | 3 | 2 | 1 | 0 |
| CRC | UNC | 0 | IDN | 0 | ABT | T0N | CCTO |
| V | 0 | 0 | V | 0 | V | 0 | V |

| Status Register | | | | | | | |
|-----------------|-----|----|-----|-----|-----|-----|-----|
| 7 | 6 | 5 | 4 | 3 | 2 | 1 | 0 |
| BSY | RDY | SE | DWE | DRQ | COR | IDX | ERR |
| 0 | V | V | 0 | - | 0 | - | V |

Table 265 Write Stream DMA Ext Command (3Ah)

The Write Stream DMA Ext command allows the host to write data using the DMA data transfer protocol. This command allows for the host to specify to the device that additional actions need to be performed prior to the completion of the command if the required bits are set.

If the Write Continuous bit is set to one, the device shall not stop execution of the command due to errors. If the WC bit is set to one and errors occur in the transfer or writing of the data, the device shall continue to transfer the amount of data requested and then provide ending status with the BSY bit cleared to zero, the SE bit set to one, the ERR bit cleared to zero, and the type of error, ICRC, IDNF, or ABRT, reported in the error log. If the WC bit is set to one and the Command Completion Time Limit expires, the device shall stop execution of the command and provide ending status with BSY bit cleared to zero, the SE bit set to one, the ERR bit cleared to zero, and report the fact that the Command Completion Time Limit expired by setting the CCTO bit in the error log to one. In all cases, the device shall attempt to transfer the amount of data requested within the Command Completion Time Limit event if some data transferred is in error.

Output Parameters To The Device

Feature Current

| | |
|-----------------------------|--|
| URG (bit7) | URG specifies an urgent transfer request. The Urgent bit specifies that the command should be completed in the minimum possible time by the device and shall be completed within the specified Command Completion Time Limit. |
| WC (bit6) | <p>WC specifies Write Continuous mode enabled. If the Write Continuous bit is set to one, the device shall not stop execution of the command due to errors.</p> <p>If the WC bit is set to one and errors occur in transfer or writing of the data, the device shall continue to transfer the amount of data requested and then provide ending status with BSY bit cleared to zero, the SE bit set to one, the ERR bit cleared to zero, and the type of error, ICRC, IDNF or ABRT reported in the error log.</p> <p>If the WC bit is set to one and the Command Completion Time Limit expires, the device shall stop execution of the command and provide ending status with the BSY bit cleared to zero, the SE bit set to one, the ERR bit cleared to zero, and report the fact that the Command Completion Time Limit expired by setting the CCTO bit in the error log to one.</p> <p>In all cases, the device shall attempt to transfer the amount of data requested within the Command Completion Time Limit even if some data transferred is in error.</p> |
| F (bit5) | F specifies that all data for the specified stream shall be flushed to the media before command complete is reported when set to one. |
| HSE (bit4) | HSE (Handle Stream Error) specifies that this command starts at the LBA of the last reported error for this stream, so the device may attempt to continue its corresponding error recovery sequence where it left off earlier. |
| Stream ID (bit 0..2) | Stream ID specifies the stream being written. The device shall operate according to the Stream ID set by the Write Stream command. |

Feature Previous

| | |
|-------------------|--|
| CCTL (7:0) | <p>The time allowed for the current command's completion is calculated as follows: Command Completion Time Limit = (content of the Feature register Previous) * (Identify Device words (99:98)) u seconds</p> <p>If the value is zero, the device shall use the Default CCTL supplied with a previous Configure Stream command for this Stream ID. If the Default CCTL is zero, or no previous Configure Stream command was defined for this Stream ID, the device will ignore the CCTL. The time is measured from the write of the command register to the final INTRQ for command completion. The device has minimum CCTL value. When the specified value is shorter than the minimum value, CCTL is set to the minimum value. Actual minimum CCTL value is described in the "Deviations from Standard" section.</p> |
|-------------------|--|

Sector Count Current

The number of continuous sectors to be transferred low order, bits (7:0)

Sector Count Previous

The number of continuous sectors to be transferred high order, bits (15:8). If zero is specified in the Sector Count register, then 65,536 sectors will be transferred.

Sector Number Current

LBA (7:0).

Sector Number Previous

LBA (31:24).

Cylinder Low Current

LBA (15:8).

Cylinder Low Previous

LBA (39:32).

Cylinder High Current

LBA (23:16).

Cylinder High Previous

LBA (47:40).

Input Parameters From The Device

| | |
|------------------------------|---|
| Sector Number (HOB=0) | LBA (7:0) of the address of the first unrecoverable error. |
| Sector Number (HOB=1) | LBA (31:24) of the address of the first unrecoverable error. |
| Cylinder Low (HOB=0) | LBA (15:8) of the address of the first unrecoverable error. |
| Cylinder Low (HOB=1) | LBA (39:32) of the address of the first unrecoverable error. |
| Cylinder High (HOB=0) | LBA (23:16) of the address of the first unrecoverable error. |
| Cylinder High (HOB=1) | LBA (47:40) of the address of the first unrecoverable error. |
| CCTO (Error, bit 0) | CCTO bit shall be set to one if a Command Completion Time Limit Out error has occurred. |

11.73 Write Stream Ext (3Bh)

| Command Block Output Registers | | | | | | | | |
|--------------------------------|----------|---|---|---|---|---|---|---|
| Register | 7 | 6 | 5 | 4 | 3 | 2 | 1 | 0 |
| Data Low | - | - | - | - | - | - | - | - |
| Data High | - | - | - | - | - | - | - | - |
| Feature | Current | V | V | V | V | - | V | V |
| | Previous | V | V | V | V | V | V | V |
| Sector Count | Current | V | V | V | V | V | V | V |
| | Previous | V | V | V | V | V | V | V |
| Sector Number | Current | V | V | V | V | V | V | V |
| | Previous | V | V | V | V | V | V | V |
| Cylinder Low | Current | V | V | V | V | V | V | V |
| | Previous | V | V | V | V | V | V | V |
| Cylinder High | Current | V | V | V | V | V | V | V |
| | Previous | V | V | V | V | V | V | V |
| Device/Head | 1 | 1 | 1 | D | - | - | - | - |
| Command | 0 | 0 | 1 | 1 | 1 | 0 | 1 | 1 |

| Command Block Input Registers | | | | | | | | |
|-------------------------------|-----------------|---|---|---|---|---|---|---|
| Register | 7 | 6 | 5 | 4 | 3 | 2 | 1 | 0 |
| Data Low | - | - | - | - | - | - | - | - |
| Data High | - | - | - | - | - | - | - | - |
| Error | ...See Below... | | | | | | | |
| Sector Count | HOB=0 | - | - | - | - | - | - | - |
| | HOB=1 | - | - | - | - | - | - | - |
| Sector Number | HOB=0 | V | V | V | V | V | V | V |
| | HOB=1 | V | V | V | V | V | V | V |
| Cylinder Low | HOB=0 | V | V | V | V | V | V | V |
| | HOB=1 | V | V | V | V | V | V | V |
| Cylinder High | HOB=0 | V | V | V | V | V | V | V |
| | HOB=1 | V | V | V | V | V | V | V |
| Device/Head | - | - | - | - | - | - | - | - |
| Status | ...See Below... | | | | | | | |

| Error Register | | | | | | | |
|----------------|-----|---|-----|---|-----|-----|------|
| 7 | 6 | 5 | 4 | 3 | 2 | 1 | 0 |
| CRC | UNC | 0 | IDN | 0 | ABT | T0N | CCTO |
| V | 0 | 0 | V | 0 | V | 0 | V |

| Status Register | | | | | | | |
|-----------------|-----|----|-----|-----|-----|-----|-----|
| 7 | 6 | 5 | 4 | 3 | 2 | 1 | 0 |
| BSY | RDY | SE | DWE | DRQ | COR | IDX | ERR |
| 0 | V | V | 0 | - | 0 | - | V |

Table 266 Write Stream Ext Command (3Bh)

This command writes from 1 to 65536 sectors as specified in the Sector Count register. A sector count of 0 requests 65536 sectors.

If the Write Continuous (WC) bit is set to one, the device shall not stop execution of the command due to errors. If the WC bit is set to one and errors occur in the transfer or writing of the data, the device shall continue to transfer the amount of data requested and then provide ending status with the BSY bit cleared to zero, the SE bit set to one, the ERR bit cleared to zero, and the type of error, IDNF, or ABRT, reported in the error log. If the WC bit is set to one and the Command Completion Time Limit expires, the device shall stop execution of the command and provide ending status with BSY bit cleared to zero, the SE bit set to one, the ERR bit cleared to zero, and report the fact that the Command Completion Time Limit expired by setting the CCTO bit in the error log to one. In all cases, the device shall attempt to transfer the amount of data requested within the Command Completion Time Limit event if some data transferred is in error.

Output Parameters To The Device

Feature Current

URG (bit7) URG specifies an urgent transfer request. The Urgent bit specifies that the command should be completed in the minimum possible time by the device and shall be completed within the specified Command Completion Time Limit.

WC (bit6) WC specifies Write Continuous mode enabled. If the Write Continuous bit is set to one, the device shall not stop execution of the command due to errors. If the WC bit is set to one and errors occur in transfer or writing of the data, the device shall continue to transfer the amount of data requested and then provide ending status with BSY bit cleared to zero, the SE bit set to one, the ERR bit cleared to zero, and the type of error, IDNF or ABRT reported in the error log. If the WC bit is set to one and the Command Completion Time Limit expires, the device shall stop execution of the command and provide ending status with the BSY bit cleared to zero, the SE bit set to one, the ERR bit cleared to zero, and report the fact that the Command Completion Time Limit expired by setting the CCTO bit in the error log to one.

In all cases, the device shall attempt to transfer the amount of data requested within the Command Completion Time Limit even if some data transferred is in error.

F (bit5) F specifies that all data for the specified stream shall be flushed to the media before command complete is reported when set to one.

HSE (bit4) HSE (Handle Stream Error) specifies that this command starts at the LBA of the last reported error for this stream, so the device may attempt to continue its corresponding error recovery sequence where it left off earlier.

Stream ID (bit 0..2) Stream ID specifies the stream being written. The device shall operate according to the Stream ID set by the Write Stream command.

Feature Previous

The time allowed for the current command's completion is calculated as follows:
Command Completion Time Limit = (content of the Feature register Previous) * (Identify Device words (99:98)) u seconds

If the value is zero, the device shall use the Default CCTL supplied with a previous Configure Stream command for this Stream ID. If the Default CCTL is zero, or no previous Configure Stream command was defined for this Stream ID, the device will ignore the CCTL. The time is measured from the write of the command register to the final INTRQ for command completion. The device has minimum CCTL value. When the specified value is shorter than the minimum value, CCTL is set to the minimum value. Actual minimum CCTL value is described in the "Deviations from Standard" section.

Sector Count Current

The number of continuous sectors to be transferred low order, bits (7:0)

Sector Count Previous

The number of continuous sectors to be transferred high order, bits (15:8). If zero is specified in the Sector Count register, then 65,536 sectors will be transferred.

Sector Number Current

LBA (7:0).

Sector Number Previous

LBA (31:24).

Cylinder Low Current

LBA (15:8).

Cylinder Low Previous

LBA (39:32).

Cylinder High Current

LBA (23:16).

Cylinder High Previous

LBA (47:40).

Input Parameters From The Device

| | |
|------------------------------|---|
| Sector Number (HOB=0) | LBA (7:0) of the address of the first unrecoverable error. |
| Sector Number (HOB=1) | LBA (31:24) of the address of the first unrecoverable error. |
| Cylinder Low (HOB=0) | LBA (15:8) of the address of the first unrecoverable error. |
| Cylinder Low (HOB=1) | LBA (39:32) of the address of the first unrecoverable error. |
| Cylinder High (HOB=0) | LBA (23:16) of the address of the first unrecoverable error. |
| Cylinder High (HOB=1) | LBA (47:40) of the address of the first unrecoverable error. |
| CCTO (Error, bit 0) | CCTO bit shall be set to one if a Command Completion Time Limit Out error has occurred. |

11.74 Write Uncorrectable Ext (45h)

| Command Block Output Registers | | | | | | | | |
|--------------------------------|----------|---|---|---|---|---|---|---|
| Register | 7 | 6 | 5 | 4 | 3 | 2 | 1 | 0 |
| Data Low | - | - | - | - | - | - | - | - |
| Data High | - | - | - | - | - | - | - | - |
| Feature | Current | V | V | V | V | V | V | V |
| | Previous | - | - | - | - | - | - | - |
| Sector Count | Current | V | V | V | V | V | V | V |
| | Previous | V | V | V | V | V | V | V |
| Sector Number | Current | V | V | V | V | V | V | V |
| | Previous | V | V | V | V | V | V | V |
| Cylinder Low | Current | V | V | V | V | V | V | V |
| | Previous | V | V | V | V | V | V | V |
| Cylinder High | Current | V | V | V | V | V | V | V |
| | Previous | V | V | V | V | V | V | V |
| Device/Head | - | 1 | - | D | - | - | - | - |
| Command | 0 | 1 | 0 | 0 | 0 | 1 | 0 | 1 |

| Command Block Input Registers | | | | | | | | |
|-------------------------------|-----------------|---|---|---|---|---|---|---|
| Register | 7 | 6 | 5 | 4 | 3 | 2 | 1 | 0 |
| Data Low | - | - | - | - | - | - | - | - |
| Data High | - | - | - | - | - | - | - | - |
| Error | ...See Below... | | | | | | | |
| Sector Count | HOB=0 | - | - | - | - | - | - | - |
| | HOB=1 | - | - | - | - | - | - | - |
| Sector Number | HOB=0 | V | V | V | V | V | V | V |
| | HOB=1 | V | V | V | V | V | V | V |
| Cylinder Low | HOB=0 | V | V | V | V | V | V | V |
| | HOB=1 | V | V | V | V | V | V | V |
| Cylinder High | HOB=0 | V | V | V | V | V | V | V |
| | HOB=1 | V | V | V | V | V | V | V |
| Device/Head | - | - | - | - | - | - | - | - |
| Status | ...See Below... | | | | | | | |

| Error Register | | | | | | | |
|----------------|-----|---|-----|---|-----|-----|-----|
| 7 | 6 | 5 | 4 | 3 | 2 | 1 | 0 |
| CRC | UNC | 0 | IDN | 0 | ABT | T0N | AMN |
| 0 | 0 | 0 | V | 0 | V | 0 | 0 |

| Status Register | | | | | | | |
|-----------------|-----|----|-----|-----|-----|-----|-----|
| 7 | 6 | 5 | 4 | 3 | 2 | 1 | 0 |
| BSY | RDY | DF | DSC | DRQ | COR | IDX | ERR |
| 0 | V | 0 | V | - | 0 | - | V |

Table 267 Write Uncorrectable Ext Command (45h)

The Write Uncorrectable Ext command is used to cause the device to report an uncorrectable error when the target sector is subsequently read.

When the Feature field contains a value of 55h the Write Uncorrectable Ext command shall cause the device to indicate a failure when reads to any of the sectors that are contained in physical block of specified sector are performed. These sectors are referred to as 'pseudo uncorrectable' sectors. In this case whenever a pseudo uncorrectable sector is accessed via a read command the drive shall perform normal error recovery to the fullest extent and then set the UNC and ERR bits to indicate the sector is bad.

When the Feature field(7:0) contains a value of AAh the Write uncorrectable ext command shall cause the device to flag the specified sector as 'flagged uncorrectable'. Flagging a logical sector as uncorrectable shall cause the device to indicate a failure when reads to the specified sector are performed. These sectors are referred to as 'flagged uncorrectable' sectors. In this case whenever a 'flagged uncorrectable' sector is accessed via a read command the device shall set the UNC and ERR bits to indicate the sector is bad.

If this command is sent to the device with the content of the Features field(7:0) set to anything other than what is defined above the device shall abort the command.

Commands that return UNC and ERR when a pseudo uncorrectable or flagged uncorrectable sector is read include: READ DMA, READ DMA EXT, READ MULTIPLE, READ MULTIPLE EXT, READ SECTOR(S), READ SECTOR(S) EXT, READ VERIFY SECTOR(S), READ, VERIFY SECTOR(S) EXT, READ STREAM EXT, READ STREAM DMA EXT. If the host writes to a 'pseudo uncorrectable' or 'flagged uncorrectable' sector, the drive shall attempt to write the data to the sector. The write shall clear the uncorrectable status of the sector and make the sector good if possible and the device shall verify that the sector may now be read without error. It is possible that an 'uncorrectable' sector location has actual physical errors. In this case read commands and/or write commands shall return ERR status information that is consistent with the error. The pseudo uncorrectable or flagged uncorrectable status of a sector shall remain through a power cycle. If the drive is unable to process a Write Uncorrectable EXT command for any reason the device shall abort the command.

Output Parameters To The Device

| | |
|-------------------------------|--|
| Feature Current | Uncorrectable options 55h :Create a pseudo-uncorrectable error with logging AAh :Created a flagged error without logging Other value : Reserved |
| Sector Count Current | The number of continuous sectors to be transferred low order, bits (7:0). |
| Sector Count Previous | The number of continuous sectors to be transferred high order bits (15:8). If zero is specified, then 65,536 sectors will be transferred. |
| Sector Number Current | LBA (7:0). |
| Sector Number Previous | LBA (31:24). |
| Cylinder Low Current | LBA (15:8). |
| Cylinder Low Previous | LBA (39:32). |
| Cylinder High Current | LBA (23:16). |
| Cylinder High Previous | LBA (47:40). |

Input Parameters From The Device

| | |
|------------------------------|--|
| Sector Number (HOB=0) | LBA (7:0) of the address of the first unrecoverable error. |
| Sector Number (HOB=1) | LBA (31:24) of the address of the first unrecoverable error. |
| Cylinder Low (HOB=0) | LBA (15:8) of the address of the first unrecoverable error. |
| Cylinder Low (HOB=1) | LBA (39:32) of the address of the first unrecoverable error. |
| Cylinder High (HOB=0) | LBA (23:16) of the address of the first unrecoverable error. |
| Cylinder High (HOB=1) | LBA (47:40) of the address of the first unrecoverable error. |